

ENGINE

ON-VEHICLE INSPECTION

1. **INSPECT ENGINE COOLANT** (See page [CO-1](#))
2. **INSPECT ENGINE OIL** (See page [LU-1](#))
3. **INSPECT BATTERY** (See page [CH-4](#))
4. **INSPECT AIR CLEANER FILTER ELEMENT SUB-ASSEMBLY**
 - (a) Remove the air cleaner filter element sub-assembly.
 - (b) Visually check that there is no dirt, blockage, or damage to the air cleaner filter element.

HINT:

- If there is any dirt or a blockage in the air cleaner filter element, clean it with compressed air.
- If any dirt or a blockage remains even after cleaning the air cleaner filter element with compressed air, replace it.

5. **INSPECT SPARK PLUG** (See page [IG-5](#))

6. **INSPECT IGNITION TIMING**

- (a) When using an intelligent tester:

- (1) Warm up and stop the engine.
- (2) Connect the intelligent tester to the DLC3.
- (3) Turn the ignition switch ON.
- (4) Select the following menu items:
DIAGNOSIS / ENHANCED OBD II/ ACTIVE TEST / TC (TE1) / ON.

HINT:

Refer to the intelligent tester operator's manual for further details.

- (5) Inspect the ignition timing during idling.

Ignition timing:

8 to 12 degrees BTDC

NOTICE:

- Turn all the electrical systems and the A/C off.
- Inspect the ignition timing with the cooling fan off.
- When checking the ignition timing, shift the transmission to the neutral position.

- (6) Select the following menu items: TC (TE1) / OFF.

- (7) Turn the ignition switch OFF.

- (8) Disconnect the intelligent tester from the DLC3.

- (b) When not using an intelligent tester:

- (1) Remove cylinder head cover No. 2 (see page [IG-9](#)).

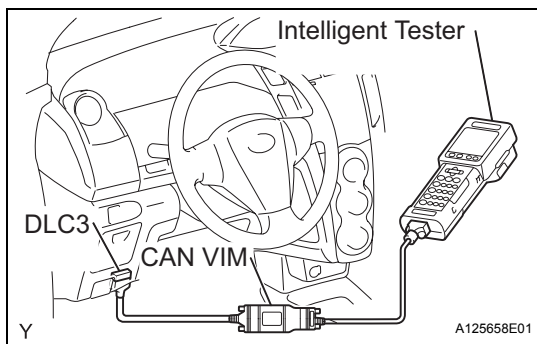

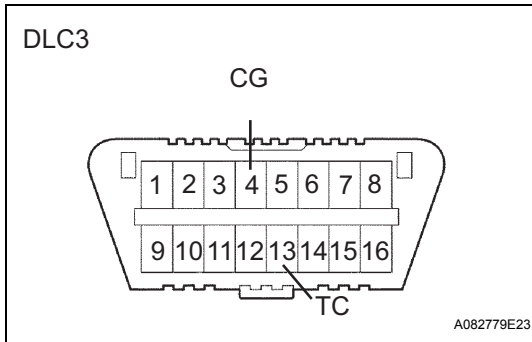
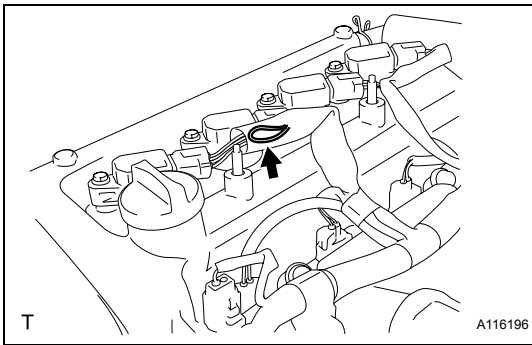

- (2) Pull out the wire harness (brown) shown in the illustration.

NOTICE:

After checking, wrap the wire harness with tape.

- (3) Warm up and stop the engine.
- (4) Connect the clip of the timing light to the wire harness.

NOTICE:

Use a timing light that detects the first signal.

- (5) Turn the ignition switch ON.
- (6) Using SST, connect terminals 13 (TC) and 4 (CG) of the DLC3.

SST 09843-18040**NOTICE:**

Examine the terminal numbers before connecting them. Connecting the wrong terminals could damage the engine.

- (7) Inspect the ignition timing during idling.

Ignition timing:

8 to 12 degrees BTDC

NOTICE:

- Turn all the electrical systems and the A/C off.
- Inspect the ignition timing with the cooling fan off.
- When checking the ignition timing, shift the transmission to the neutral position.

- (8) Disconnect terminals 13 (TC) and 4 (CG) of the DLC3.
- (9) Turn the ignition switch OFF.
- (10) Remove the timing light.
- (11) Install cylinder head cover No. 2 (see page IG-10).

7. INSPECT ENGINE IDLING SPEED

- (a) When using an intelligent tester:

- (1) Warm up and stop the engine.
- (2) Connect the intelligent tester to the DLC3.
- (3) Turn the ignition switch ON.
- (4) Select the following menu items:
DIAGNOSIS / ENHANCED OBD II/ DATA LIST / PRIMARY / ENGINE SPD.

HINT:

Refer to the intelligent tester operator's manual for further details.

- (5) Inspect the engine idling speed.

Idling speed:

550 to 650 rpm for manual transaxle

650 to 750 rpm for automatic transaxle

NOTICE:

- Turn all the electrical systems and the A/C off.

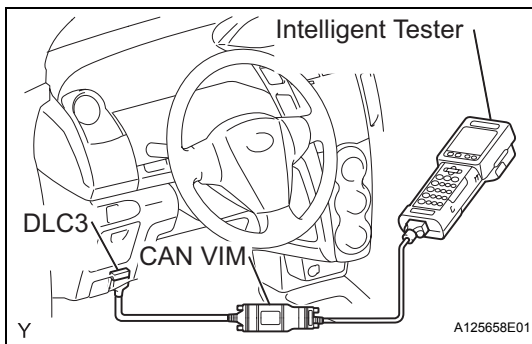

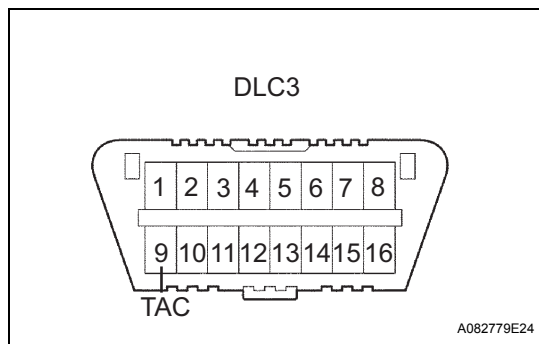

- Inspect the idling speed with the cooling fan off.
 - When checking the idling speed, shift the transmission to either the neutral position or the parking position.
- (6) Turn the ignition switch OFF.
 - (7) Disconnect the intelligent tester from the DLC3.
- (b) When not using an intelligent tester.

- (1) Warm up and stop the engine.
- (2) Install SST to terminal 9 (TAC) of the DLC3, then connect a tachometer.

SST 09843-18040

NOTICE:

Examine the terminal numbers before connecting them. Connecting the wrong terminals could damage the engine.

- (3) Turn the ignition switch ON.
- (4) Inspect the engine idling speed.

Idling speed:

550 to 650 rpm for manual transaxle

650 to 750 rpm for automatic transaxle

- (5) Turn the ignition switch OFF.
- (6) Disconnect the tachometer.
- (7) Remove SST from terminal 9 (TAC).

8. INSPECT COMPRESSION

- (a) Warm up and stop the engine.
- (b) Remove cylinder head cover No. 2 (see page IG-9).
- (c) Remove the 4 ignition coils (see page IG-9).
- (d) Remove the 4 spark plugs.
- (e) Disconnect the 4 fuel injector connectors.
- (f) Inspect the cylinder compression pressure.
 - (1) Insert a compression gauge into the spark plug hole.
 - (2) Fully open the throttle.
 - (3) While cranking the engine, measure the compression pressure.

Compression:

1,471kPa (15.0 kgf/cm², 213 psi)

Minimum pressure:

1,079 kPa (11.0 kgf/cm², 156 psi)

Difference between each cylinder:

98 kPa (1.0 kgf/cm², 14 psi) or less

NOTICE:

- Use a fully-charged battery so the engine speed can be increased to 250 rpm or more.
- Inspect the other cylinders in the same way.
- Measure the compression in as short a time as possible.

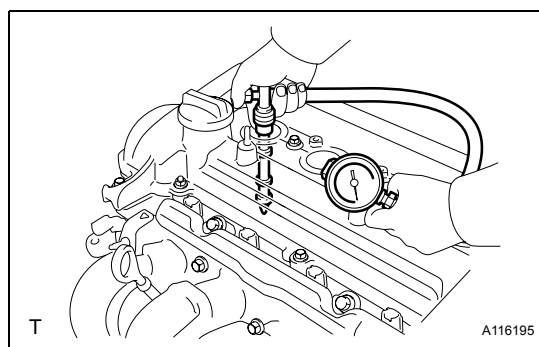

- (4) If the cylinder compression is low, pour a light coat of engine oil into the cylinder through the spark plug hole, then inspect it again.

HINT:

- If adding oil increases the compression, the piston rings and/or cylinder bore may be worn or damaged.
- If the pressure stays low, the valve may be stuck or seated improperly, or there may be leakage from the gasket.

(g) Connect the 4 fuel injector connectors.

(h) Install the 4 spark plugs.

Torque: 18 N*m (184 kgf*cm, 13 ft.*lbf)

(i) Install the 4 ignition coils (see page [IG-9](#)).

(j) Install cylinder head cover No. 2 (see page [IG-10](#)).

9. INSPECT CO/HC

(a) Start the engine.

(b) Run the engine at 2,500 rpm for approximately 180 seconds.

(c) Insert the CO/HC meter testing probe at least 40 cm (1.3 ft) into the tailpipe while idling.

(d) Check the CO/HC concentration during idling and when running at 2,500 rpm.

HINT:

When doing the 2 mode (with the engine idling/running at 2,500 rpm) test, the measuring procedures are determined by applicable local regulations.

If the CO/HC concentration does not comply with the regulations, troubleshoot in the order given below.

- (1) Check the heated oxygen sensor operation (see page [ES-276](#)).
- (2) See the table below for possible causes, then inspect the applicable parts and repair them if necessary.

CO	HC	Problems	Possible Causes
Normal	High	Rough idling	<ol style="list-style-type: none"> 1. Faulty ignition: <ul style="list-style-type: none"> – Incorrect timing – Fouled, shorted or improperly gapped plugs 2. Incorrect valve clearance 3. Leakage from intake and exhaust valves 4. Leakage from cylinders
Low	High	Rough idling (Fluctuating HC reading)	<ol style="list-style-type: none"> 1. Vacuum leaks: <ul style="list-style-type: none"> – PCV hoses – Intake manifold – Throttle body – Brake booster line 2. Lean mixture causing misfire
High	High	Rough idling (Black smoke from exhaust)	<ol style="list-style-type: none"> 1. Restricted air cleaner filter element 2. Plugged PCV valve 3. Faulty EFI systems: <ul style="list-style-type: none"> – Faulty pressure regulator – Faulty engine coolant temperature sensor – Faulty mass air flow meter – Faulty ECM – Faulty injectors – Throttle body

DRIVE BELT COMPONENTS

EM

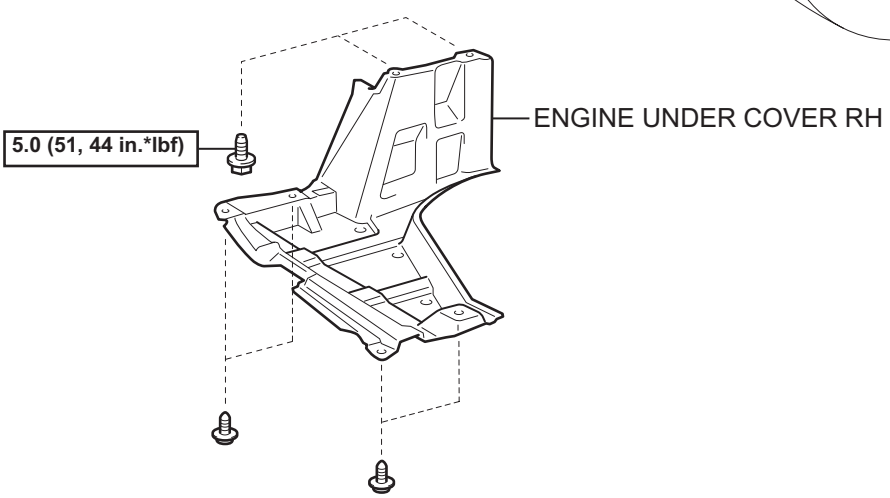
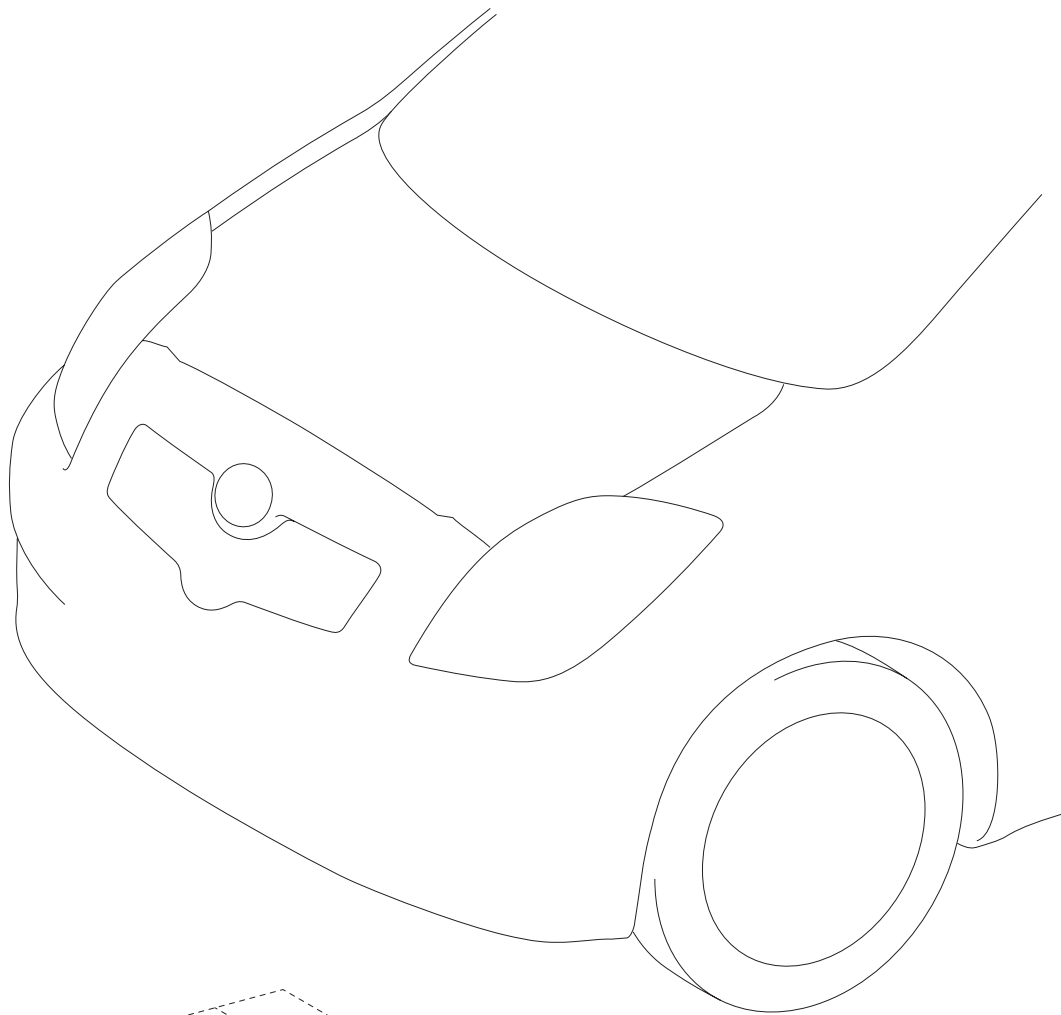

N*m (kgf*cm, ft.*lbf): Specified torque

EM

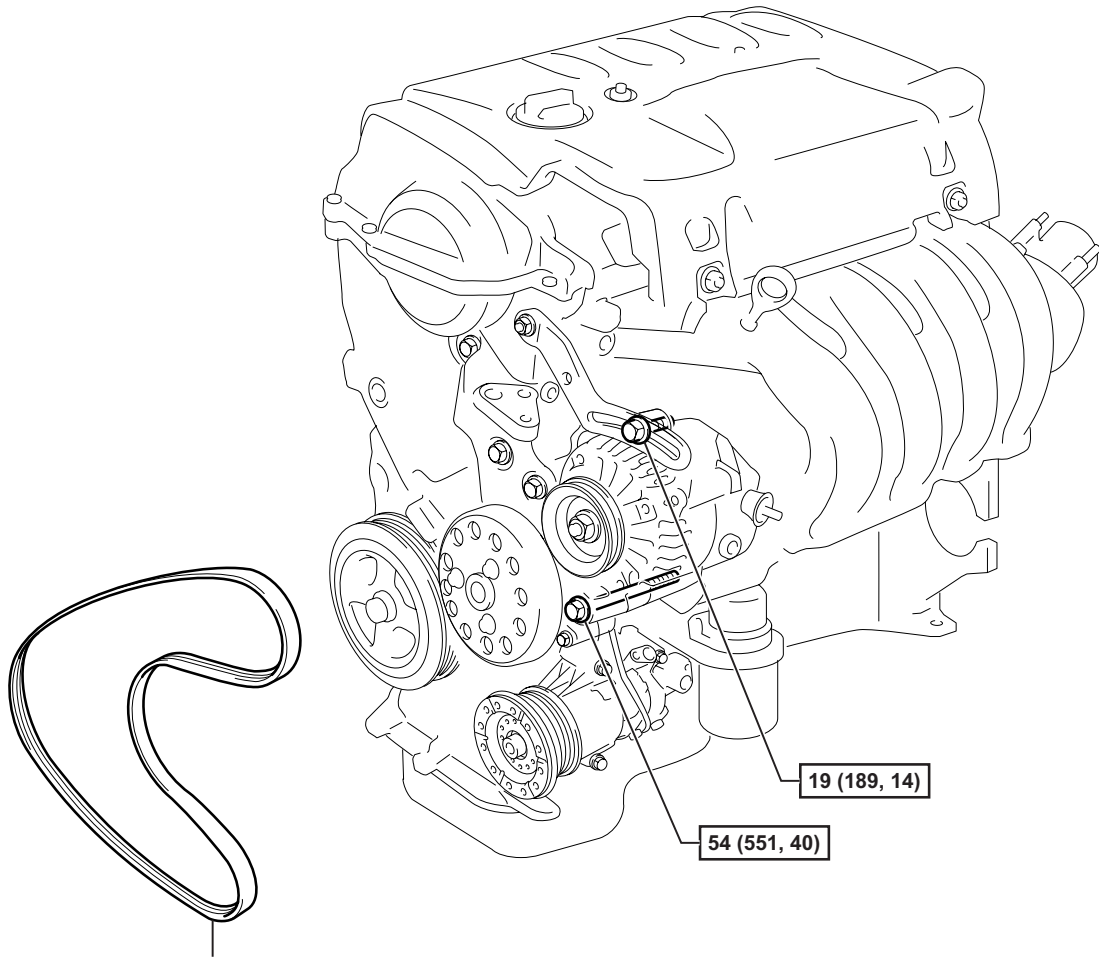

FAN AND GENERATOR V BELT

N*m (kgf*cm, ft.*lbf) : Specified torque

T

REMOVAL

1. REMOVE ENGINE UNDER COVER RH
2. REMOVE FAN AND GENERATOR V BELT
 - (a) Loosen bolts A and B.
 - (b) Release the fan and generator V belt tension and remove the fan and generator V belt.

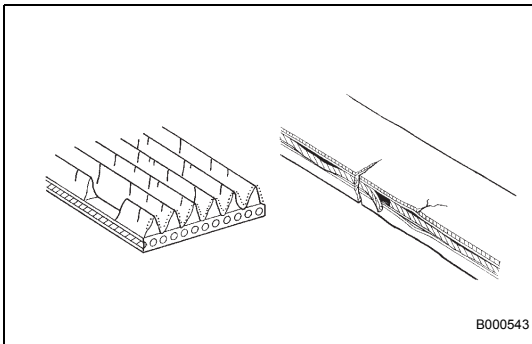
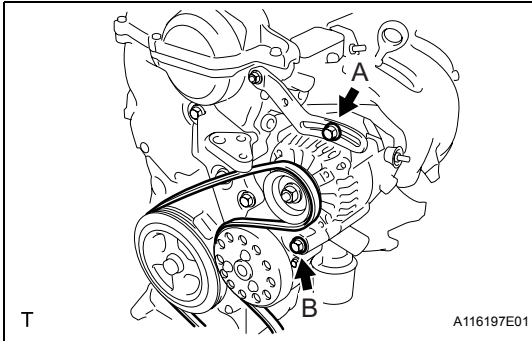

INSPECTION

1. INSPECT FAN AND GENERATOR V BELT
 - (a) Visually check the belt for excessive wear, frayed cords etc. If any defects are found, replace the belt.
HINT:
 - If any defects are found, replace the belt.
 - Cracks on the rib side of a belt are considered acceptable. If the belt has pieces missing from the ribs, it should be replaced.

INSTALLATION

1. INSTALL FAN AND GENERATOR V BELT

- (a) Provisionally install the fan and generator V belt onto each pulley.

NOTICE:

Make sure that the V-belt is securely fitted into the rib groove of the pulley.

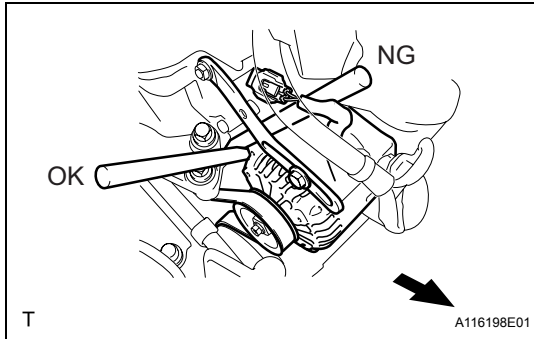

2. ADJUST FAN AND GENERATOR V BELT

- (a) Insert an adjusting bar between the engine mounting bracket and generator assembly. Push the adjusting bar toward the vehicle front to adjust the generator V belt tension.

NOTICE:

Do not insert the adjusting bar between the camshaft timing oil control valve assembly and generator assembly. It could damage the camshaft timing oil control valve assembly.

- (b) First tighten bolt A, then tighten bolt B.

**Torque: 19 N*m (189 kgf*cm, 14 ft.*lbf) for bolt A
54 N*m (551 kgf*cm, 40 ft.*lbf) for bolt B**

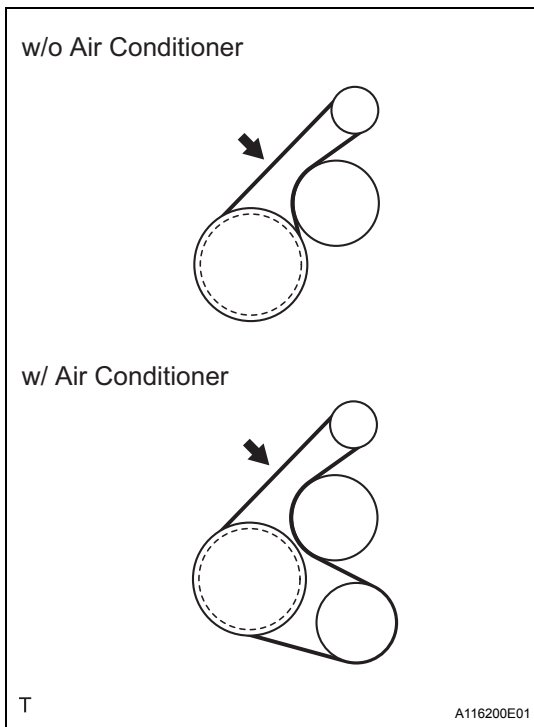
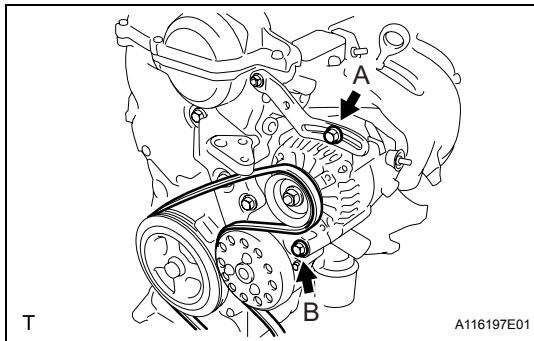

3. INSPECT FAN AND GENERATOR V BELT

- (a) Check the V belt deflection and tension.

Deflection

Item	Specified Condition
New belt	7.0 to 8.5 mm (0.28 to 0.33 in)
Used belt	11 to 13 mm (0.43 to 0.51 in)

Tension

Item	Specified Condition
New belt	539 to 637 N (55 to 65 kg, 121 to 143 ld)
Used belt	245 to 392 N (25 to 40 kg, 55 to 88 ld)

If the belt deflection is not as specified, adjust it.

HINT:

- Check the V belt deflection at the specified point.
- Check the drive belt deflection at the specified point.
- When installing a new belt, set its tension to the specified value.
- When inspecting a belt which has been used for over 5 minutes, apply the used belt specifications.

- When reinstalling a belt which has been used for over 5 minutes, adjust its deflection and tension to the intermediate values of each used belt specification.
- V-ribbed belt tension and deflection should be checked after 2 revolutions of engine cranking.
- When using a belt tension gauge, confirm its accuracy by using a master gauge first.

4. INSTALL ENGINE UNDER COVER RH

VALVE CLEARANCE

ADJUSTMENT

1. DISCONNECT CABLE FROM NEGATIVE BATTERY TERMINAL
2. REMOVE ENGINE UNDER COVER RH
3. REMOVE CYLINDER HEAD COVER NO. 2 (See page [IG-9](#))
4. REMOVE IGNITION COIL NO. 1 (See page [IG-9](#))
5. DISCONNECT VENTILATION HOSE (See page [FU-13](#))
6. DISCONNECT VENTILATION HOSE NO. 2 (See page [FU-13](#))
7. REMOVE CYLINDER HEAD COVER SUB-ASSEMBLY (See page [FU-13](#))
8. INSPECT VALVE CLEARANCE

HINT:

Inspect the valve clearance when the engine is cold.

- (a) Set the No. 1 cylinder to TDC/compression.
 - (1) Turn the crankshaft damper and align its timing notch with the timing mark "0" of the oil pump.

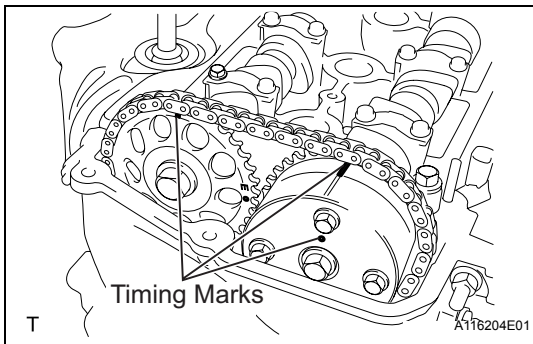
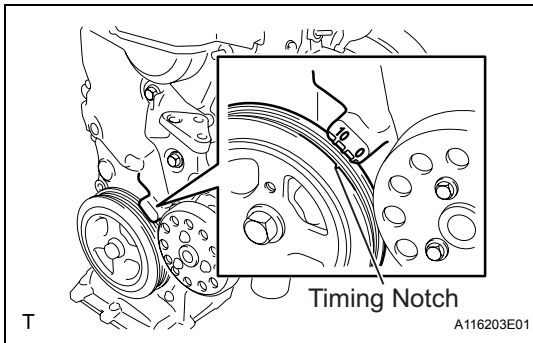

- (2) Check that both timing marks on the camshaft timing sprocket and camshaft timing gear are facing upward, as shown in the illustration.

HINT:

If not, turn the crankshaft 1 complete revolution (360°) and align the marks as above.

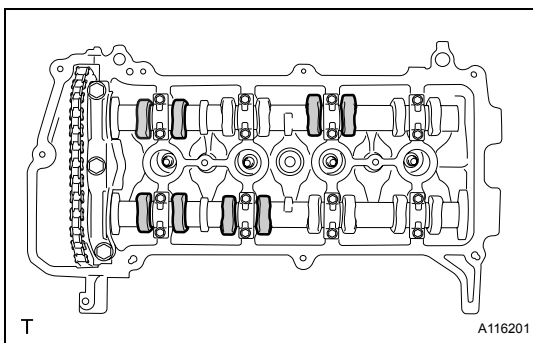

- (b) Check the valves indicated in the illustration.
 - (1) Using a feeler gauge, measure the clearance between the valve lifter and camshaft.

Valve clearance (cold):

for intake:

0.15 to 0.25 mm (0.006 to 0.010 in.)

for exhaust:

0.25 to 0.35 mm (0.010 to 0.014 in.)

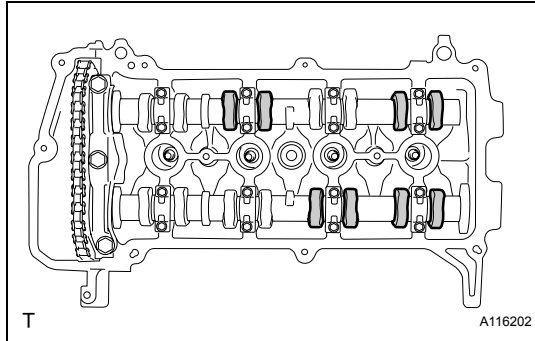

- (2) Record any out-of-specification valve clearance measurements. They will be used later to determine the required replacement adjusting shim.
- (c) Turn the crankshaft 1 complete revolution (360°) and align its timing notch with the timing mark "0" of the oil pump.

- (d) Check the valves indicated in the illustration.
 - (1) Using a feeler gauge, measure the clearance between the valve lifter and camshaft.

Valve clearance (cold):

for intake:

0.15 to 0.25 mm (0.006 to 0.010 in.)

for exhaust:

0.25 to 0.35 mm (0.010 to 0.014 in.)

- (2) Record any out-of-specification valve clearance measurements. They will be used later to determine the required replacement adjusting shim.

9. ADJUST VALVE CLEARANCE

NOTICE:

When rotating the camshaft with the timing chain removed, rotate the crankshaft damper counterclockwise 40° from the TDC and align its timing notch with the matchmark of the timing chain cover to prevent the pistons from coming into contact with the valves.

- (a) Remove the fan and generator V belt (See page [EM-7](#)).
- (b) Remove the engine mounting insulator sub-assembly RH (See page [LU-17](#)).
- (c) Set the No. 1 cylinder to TDC/compression.
 - (1) Turn the crankshaft damper and align its timing notch with the timing mark "0" of the oil pump.

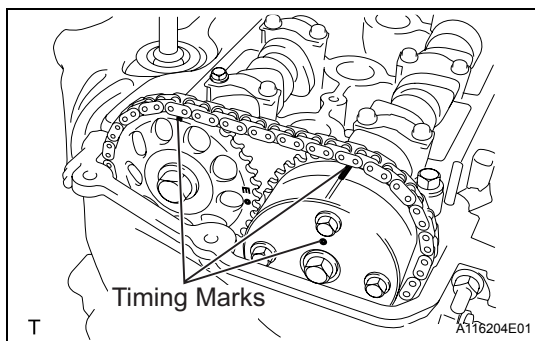
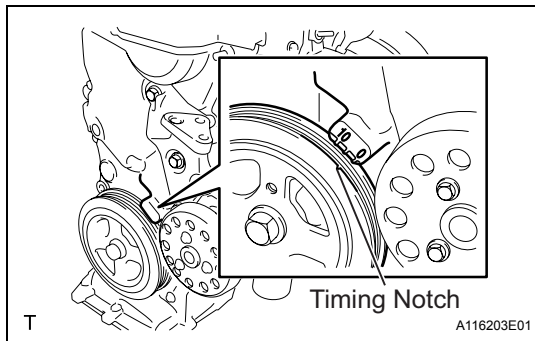
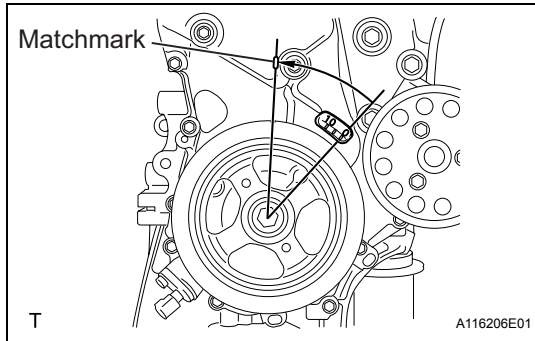

- (2) Check that both timing marks on the camshaft timing sprocket and camshaft timing gear are facing upward, as shown in the illustration.

HINT:

If not, turn the crankshaft 1 complete revolution (360°) and align the marks as above.

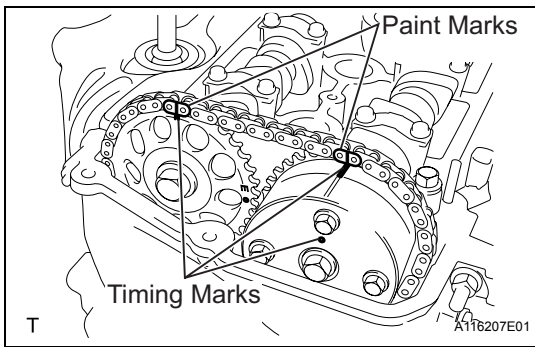

- (d) Place paint marks on the chain in the places where the timing marks of the camshaft timing sprocket and the camshaft timing gear are located.

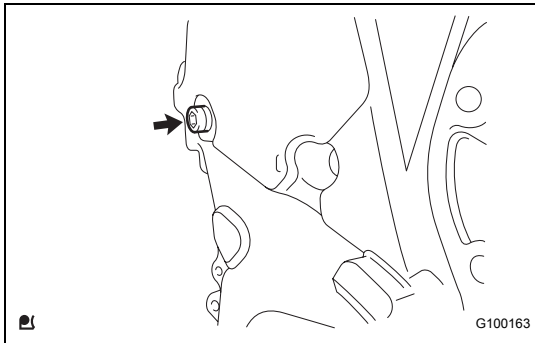

- (e) Using an 8 mm hexagon wrench, remove the screw plug.

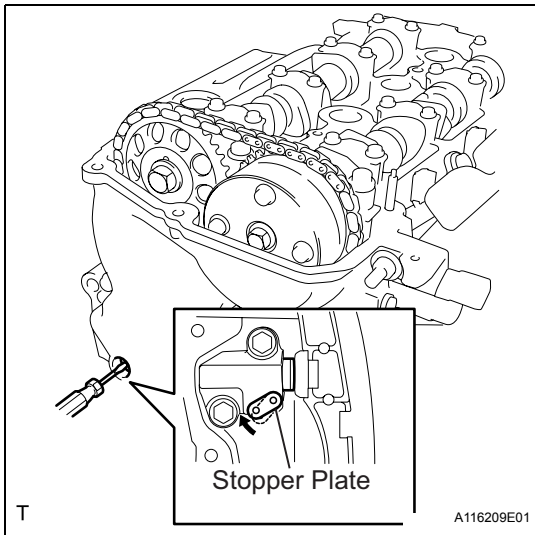

- (f) Insert a screwdriver into the service hole in the chain tensioner to pull the stopper plate of the chain tensioner upward.

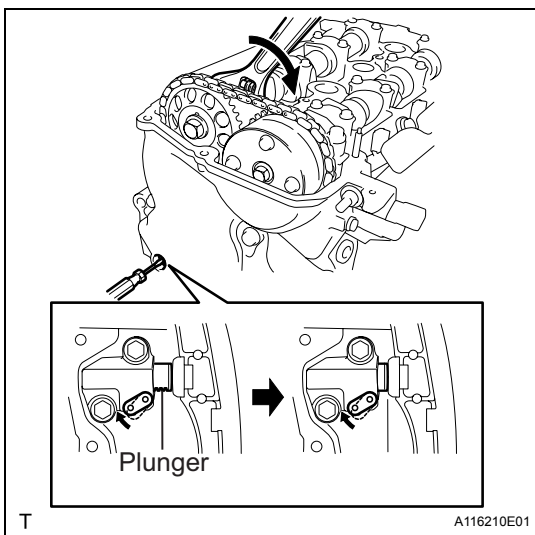

- (g) Using a wrench, rotate camshaft No. 2 clockwise to push in the plunger of the chain tensioner.

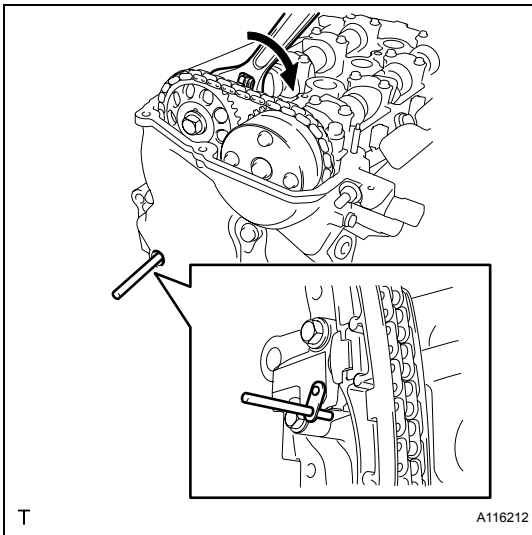

- (h) Remove the screwdriver from the service hole, then align the hole in the stopper plate with the service hole and insert a 3 mm (0.12 in.) diameter bar into the holes to hold the stopper plate.

HINT:

- Fix the stopper plate using the bar while rotating the camshaft right and left slightly.
- Hold the bar with tape so that the bar does not come off.

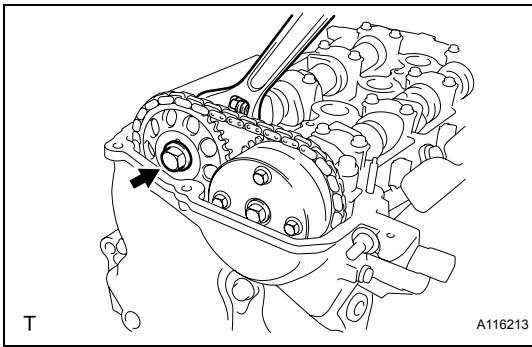

- (i) Using a wrench, hold the hexagonal lobe of camshaft No. 2 and remove the fringe bolt.

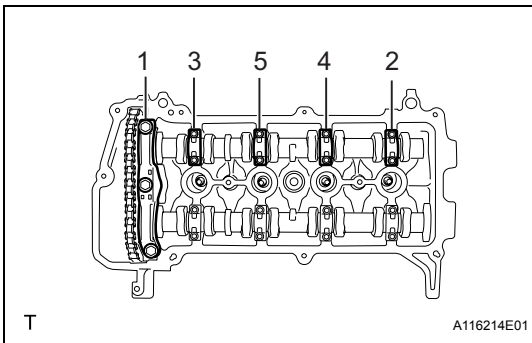

- (j) Using several steps, loosen and remove the 11 bearing cap bolts uniformly in the sequence shown in the illustration, then remove camshaft bearing cap No. 1 and camshaft bearing cap No. 2.

NOTICE:

Loosen each bolt uniformly while keeping the camshaft level.

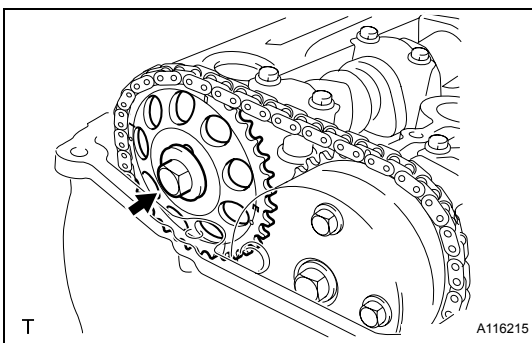

- (k) Remove the fringe bolt and remove the camshaft timing sprocket.

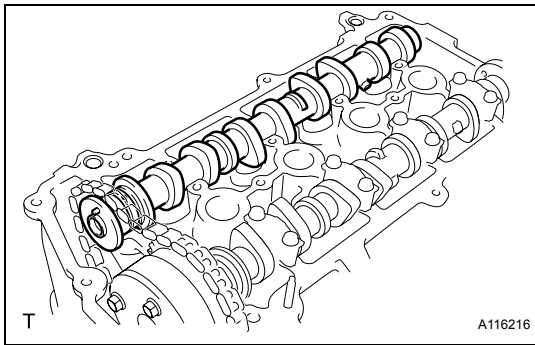

(l) Remove camshaft No. 2.

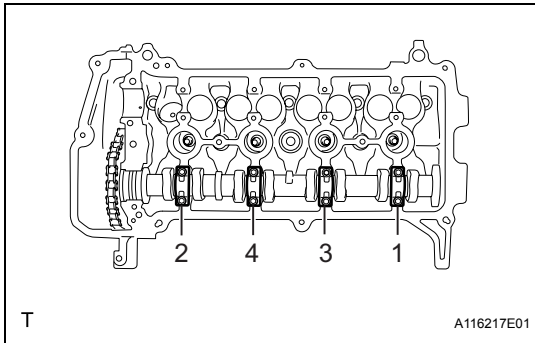

(m) Using several steps, loosen and remove the 8 bearing cap bolts uniformly in the sequence shown in the illustration, then remove camshaft bearing cap No. 2.

NOTICE:

Loosen each bolt uniformly while keeping the camshaft level.

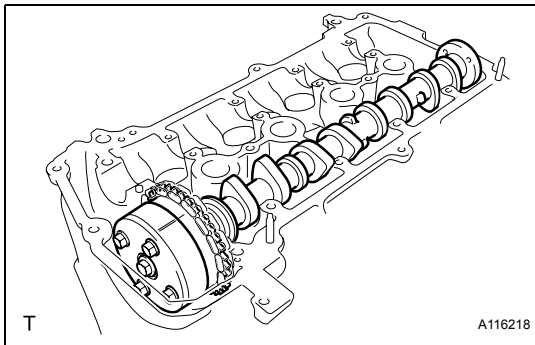

(n) Hold the chain by hand and remove the camshaft and the camshaft timing gear assembly.

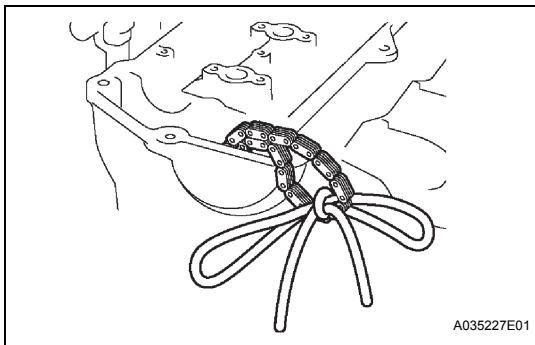

(o) Tie the chain with a piece of string as shown in the illustration.

(p) Remove the 16 valve lifters.

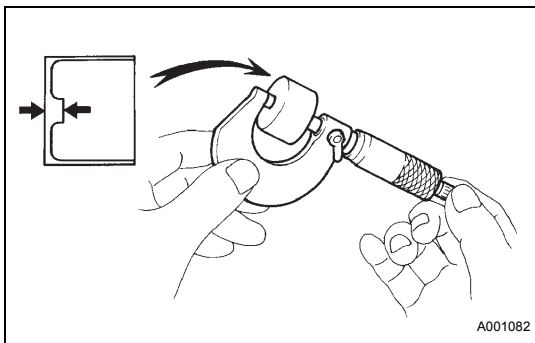

(q) Using a micrometer, measure the thickness of the removed lifter.

(r) Calculate the thickness of a new lifter so that the valve clearance comes to within the specified values.

A	Thickness of new lifter
B	Thickness of used lifter
C	Measured valve clearance

Valve clearance:**Intake $A = B + (C - 0.20 \text{ mm (0.008 in.)})$** **Exhaust $A = B + (C - 0.30 \text{ mm (0.012 in.)})$**

- (s) Select a new lifter with a thickness as close to the calculated values as possible.

HINT:

Lifters are available in 35 sizes in increments of 0.020mm (0.0008 in.), from 5.060 mm (0.1992 in.) to 5.740 mm (0.2260 in.).

Intake valve clearance (cold):
0.15 to 0.25 mm (0.006 to 0.010 in.)

EXAMPLE:

A 5.250 mm (0.2067 in.) lifter is installed, and the measured clearance is 0.400 mm (0.0158 in.). Replace the 5.250 mm (0.2067 in.) lifter with a new No. 46 lifter.

New Shim Thickness

Shim No.	Thickness	Shim No.	Thickness	Shim No.	Thickness
06	5.060 (0.1992)	30	5.300 (0.2087)	54	5.540 (0.2181)
08	5.080 (0.2000)	32	5.320 (0.2094)	56	5.560 (0.2189)
10	5.100 (0.2008)	34	5.340 (0.2102)	58	5.580 (0.2197)
12	5.120 (0.2016)	36	5.360 (0.2110)	60	5.600 (0.2205)
14	5.140 (0.2024)	38	5.380 (0.2118)	62	5.620 (0.2213)
16	5.160 (0.2031)	40	5.400 (0.2126)	64	5.640 (0.2220)
18	5.180 (0.2039)	42	5.420 (0.2134)	66	5.660 (0.2228)
20	5.200 (0.2047)	44	5.440 (0.2142)	68	5.680 (0.2236)
22	5.220 (0.2055)	46	5.460 (0.2150)	70	5.700(0.2244)
24	5.240 (0.2063)	48	5.480 (0.2157)	72	5.720 (0.2252)
26	5.260 (0.2071)	50	5.500 (0.2165)	74	5.740 (0.2260)
28	5.280 (0.2079)	52	5.520 (0.2173)		

Exhaust valve clearance (Cold):
0.25 to 0.35 mm (0.010 to 0.014 in.)

EXAMPLE:

A 5.340 mm (0.2102 in.) lifter is installed, and the measured clearance is 0.440 mm (0.0173 in.). Replace the 5.340 mm (0.2102 in.) lifter with a new No. 48 lifter.

New Shim Thickness

Shim No.	Thickness	Shim No.	Thickness	Shim No.	Thickness
06	5.060 (0.1992)	30	5.300 (0.2087)	54	5.540 (0.2181)
08	5.080 (0.2000)	32	5.320 (0.2094)	56	5.560 (0.2189)
10	5.100 (0.2008)	34	5.340 (0.2102)	58	5.580 (0.2197)
12	5.120 (0.2016)	36	5.360 (0.2110)	60	5.600 (0.2205)
14	5.140 (0.2024)	38	5.380 (0.2118)	62	5.620 (0.2213)
16	5.160 (0.2031)	40	5.400 (0.2126)	64	5.640 (0.2220)
18	5.180 (0.2039)	42	5.420 (0.2134)	66	5.660 (0.2228)
20	5.200 (0.2047)	44	5.440 (0.2142)	68	5.680 (0.2236)
22	5.220 (0.2055)	46	5.460 (0.2150)	70	5.700 (0.2244)
24	5.240 (0.2063)	48	5.480 (0.2157)	72	5.720 (0.2252)
26	5.260 (0.2071)	50	5.500 (0.2165)	74	5.740 (0.2260)
28	5.280 (0.2079)	52	5.520 (0.2173)		

- (t) Install the selected valve lifter.
- (u) Apply a light coat of engine oil to the camshaft and camshaft journals.
- (v) Install the chain onto the camshaft timing gear with the paint mark and the timing mark aligned as shown in the illustration.

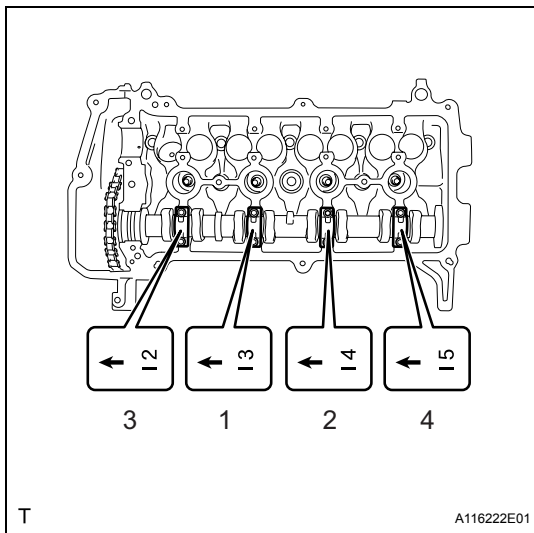
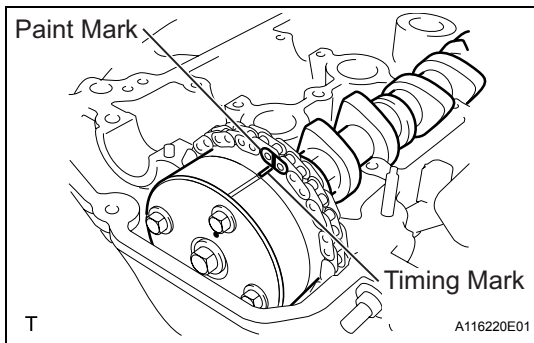

- (w) Examine the front marks and the numbers on camshaft bearing cap No. 2 and check that the sequence is as shown in the illustration. Then uniformly tighten the bolts in several steps in the sequence shown in the illustration.
Torque: 13 N*m (129 kgf*cm, 9.4 ft.*lbf)
NOTICE:
Tighten each bolt uniformly while keeping the camshaft level.

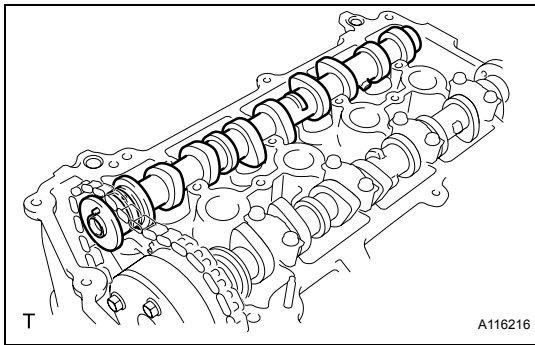

(x) Install camshaft No. 2.

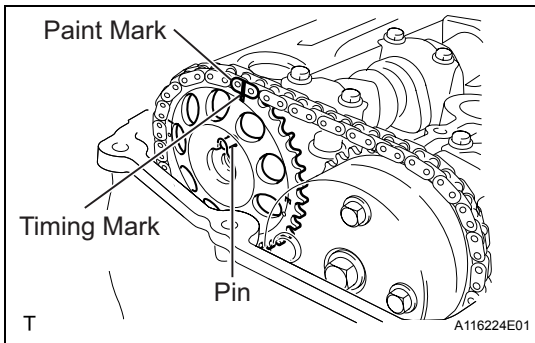

- (y) Hold the chain, and align the timing mark on the camshaft timing sprocket with the paint mark of the chain.
- (z) Align the alignment pin hole in the camshaft timing sprocket with the alignment pin of the camshaft, and install the sprocket onto the camshaft.

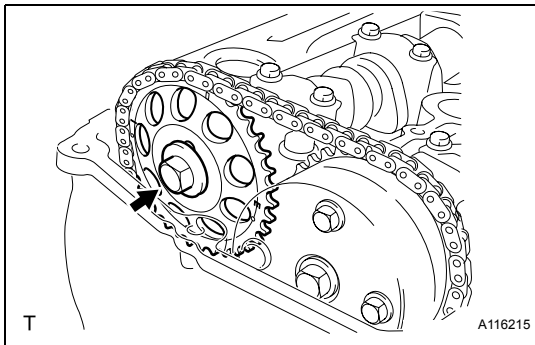

(aa) Provisionally install the flange bolt.

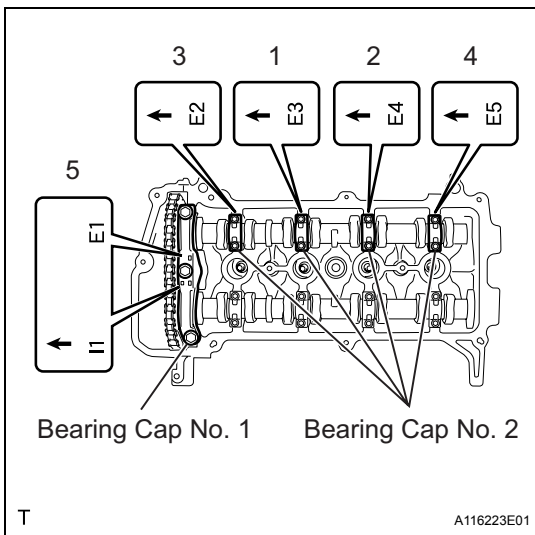

(ab) Examine the front marks and the numbers of camshaft bearing cap No. 1 and camshaft bearing cap No. 2 and check that the sequence is as shown in the illustration. Then uniformly tighten the bolts in several steps, in the sequence shown in the illustration.

Torque: for bearing cap No. 2
 13 N*m (129 kgf*cm, 9.4 ft.*lbf)
for bearing cap No. 1
 23 N*m (235 kgf*cm, 17 ft.*lbf)

NOTICE:
 Tighten each bolt uniformly while keeping the camshaft level.

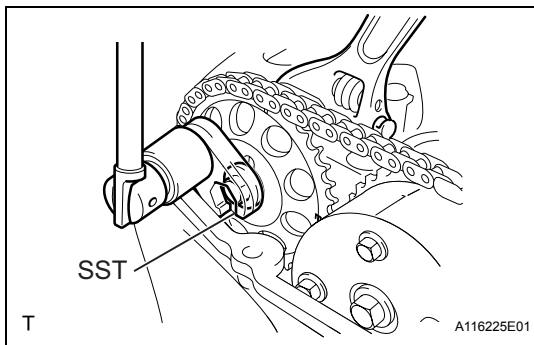

(ac) Using a wrench, hold the hexagonal lobe of camshaft No. 2 and install the flange bolt.

Torque: 64 N*m (653 kgf*cm, 47 ft.*lbf)
SST 09023-38400

(ad) Remove the bar from the timing chain tensioner.

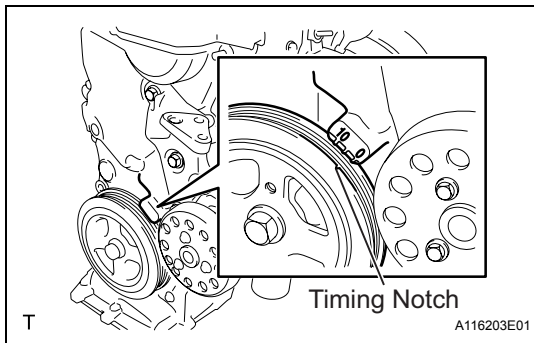

(ae) Turn the crankshaft damper and align its timing notch with the timing mark "0" of the oil pump.

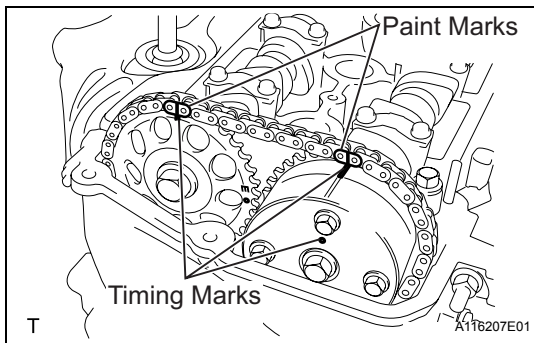

(af) Check that all the pairs of timing marks are aligned.

(ag) Apply adhesive to the 2 or 3 threads of the screw plug.

Adhesive:

Toyota Genuine Adhesive 1324, Three Bond 1324 or Equivalent

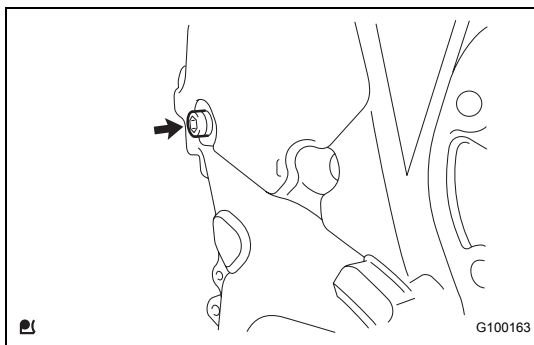

(ah) Using an 8 mm hexagon wrench, install the screw plug.

Torque: 15 N*m (153 kgf*cm, 11 ft.*lbf)

(ai) Install the engine mounting insulator sub-assembly RH (See page [LU-26](#)). (for Hatchback)

(aj) Install the engine mounting insulator sub-assembly RH (See page [LU-26](#)). (for Sedan)

(ak) Install the fan and generator V belt (See page [EM-7](#)).

(al) Adjust the fan and generator V belt (See page [EM-7](#)).

(am) Inspect the fan and generator V belt (See page [EM-8](#)).

10. INSTALL CYLINDER HEAD COVER SUB-ASSEMBLY
(See page [FU-19](#))

11. CONNECT VENTILATION HOSE NO. 2 (See page [FU-20](#))

12. CONNECT VENTILATION HOSE (See page [FU-20](#))

13. INSTALL IGNITION COIL NO. 1 (See page [IG-9](#))

14. **CONNECT CABLE TO NEGATIVE BATTERY
TERMINAL**
Torque: 5.4 N*m (55 kgf*cm, 48 in.*lbf)
15. **CHECK FOR ENGINE OIL LEAKAGE**
16. **INSTALL CYLINDER HEAD COVER NO. 2 (See page
[IG-10](#))**
17. **INSTALL ENGINE UNDER COVER RH**

TIMING CHAIN

COMPONENTS

EM

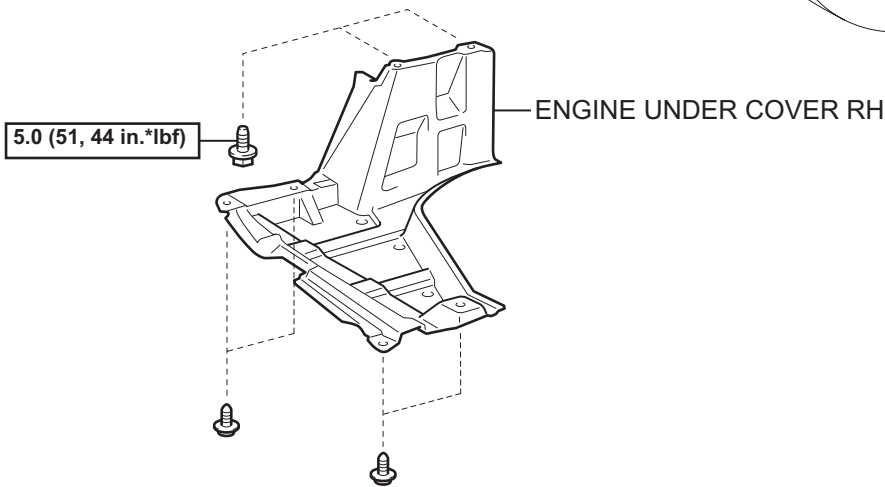
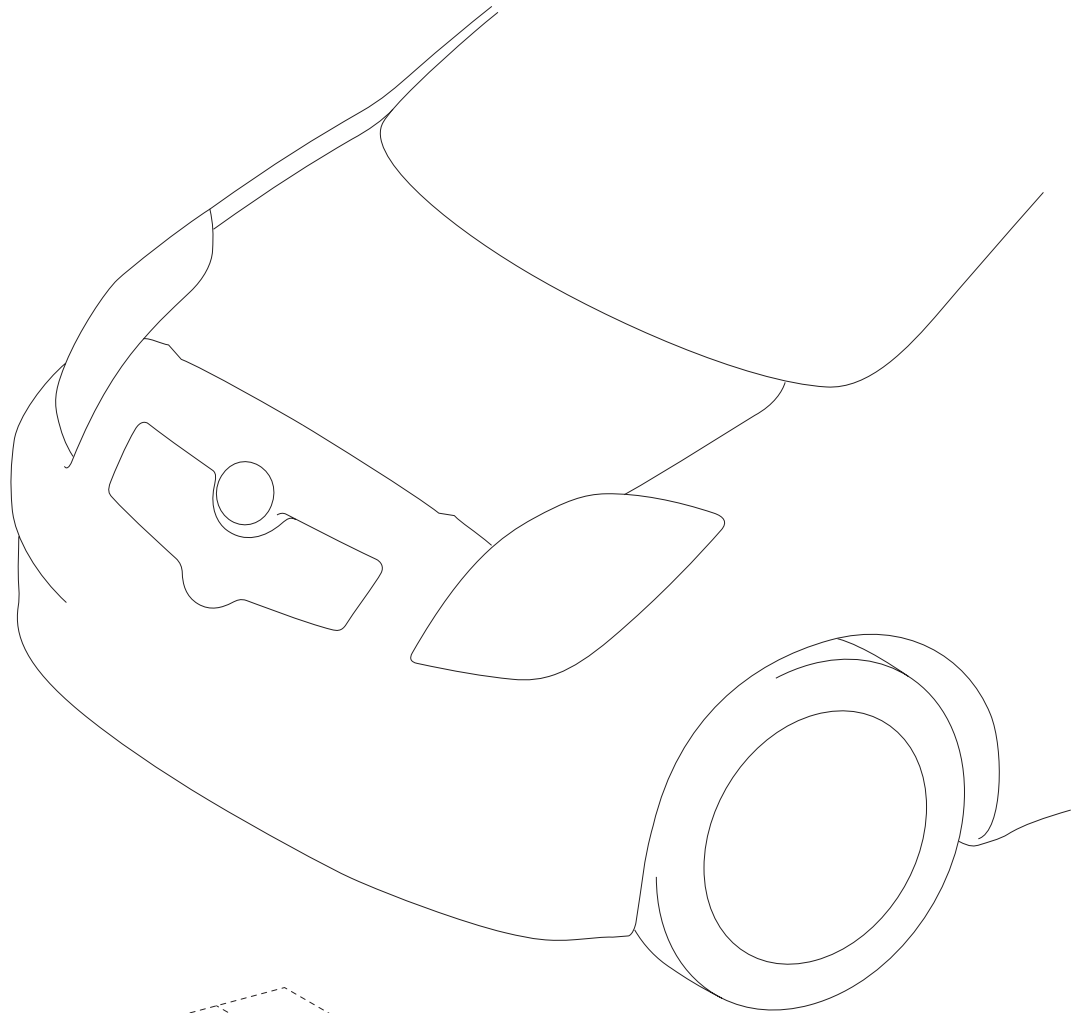

N*m (kgf*cm, ft.*lbf) : Specified torque

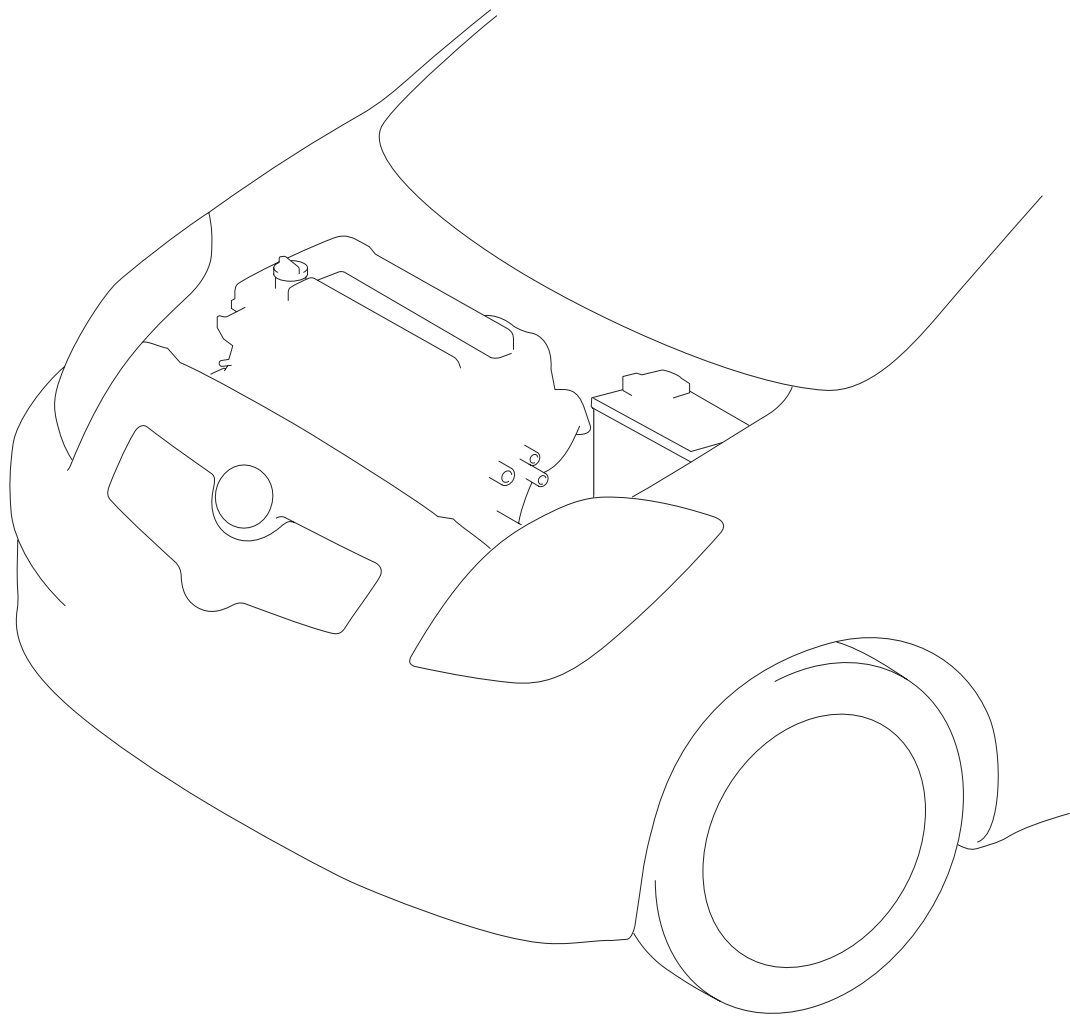
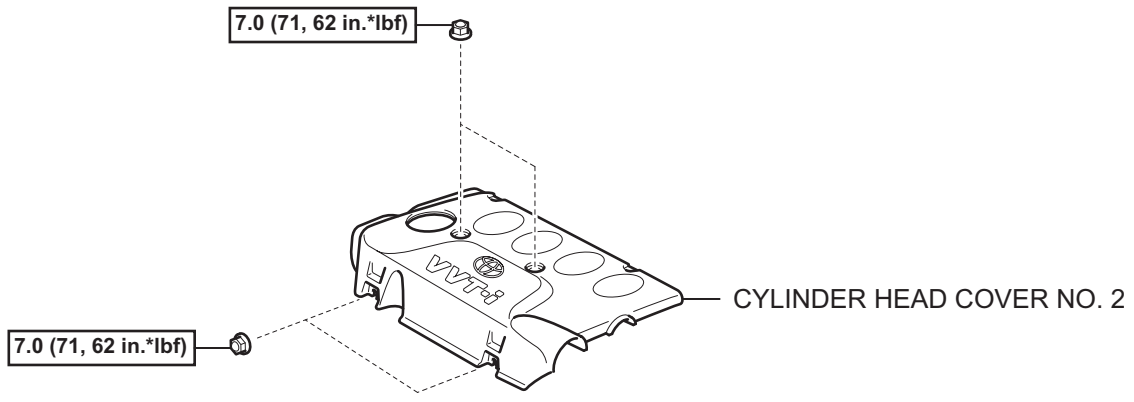

N*m (kgf*cm, ft.*lbf) : Specified torque

EM

T

EM

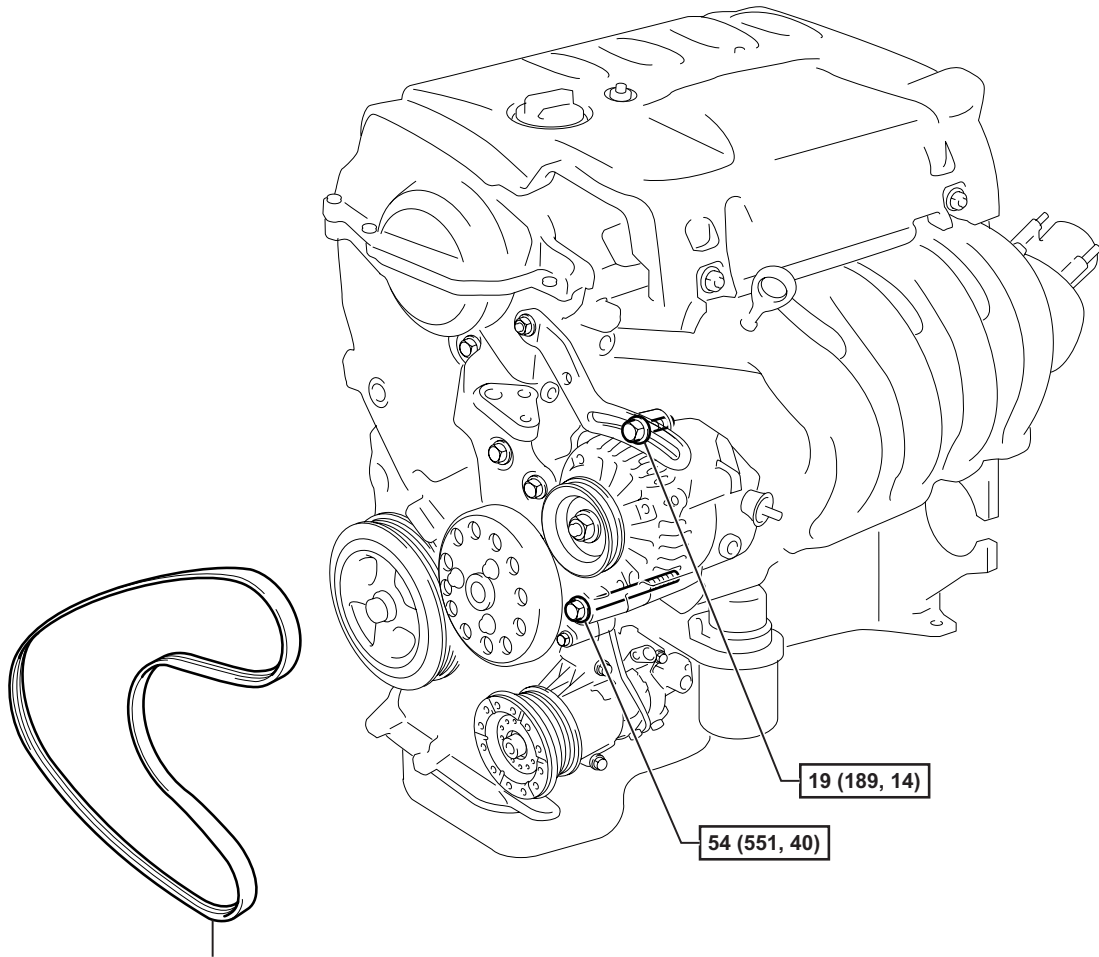

FAN AND GENERATOR V BELT

N*m (kgf*cm, ft.*lbf) : Specified torque

T

for Hatchback:

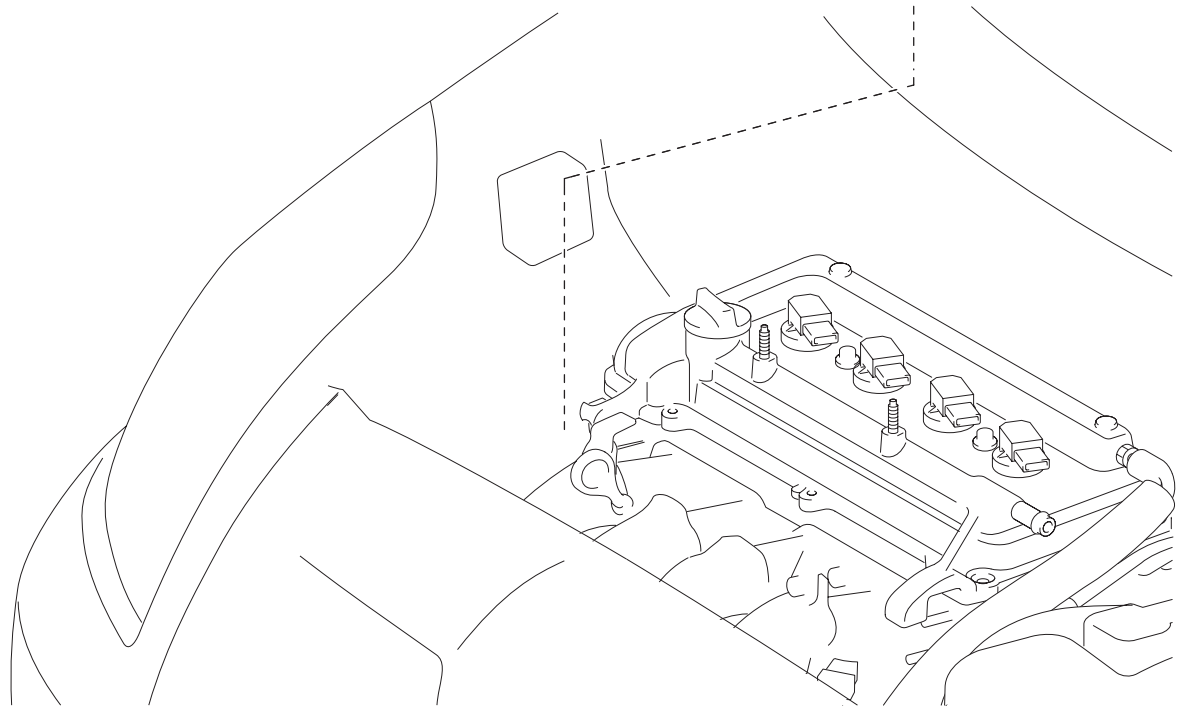
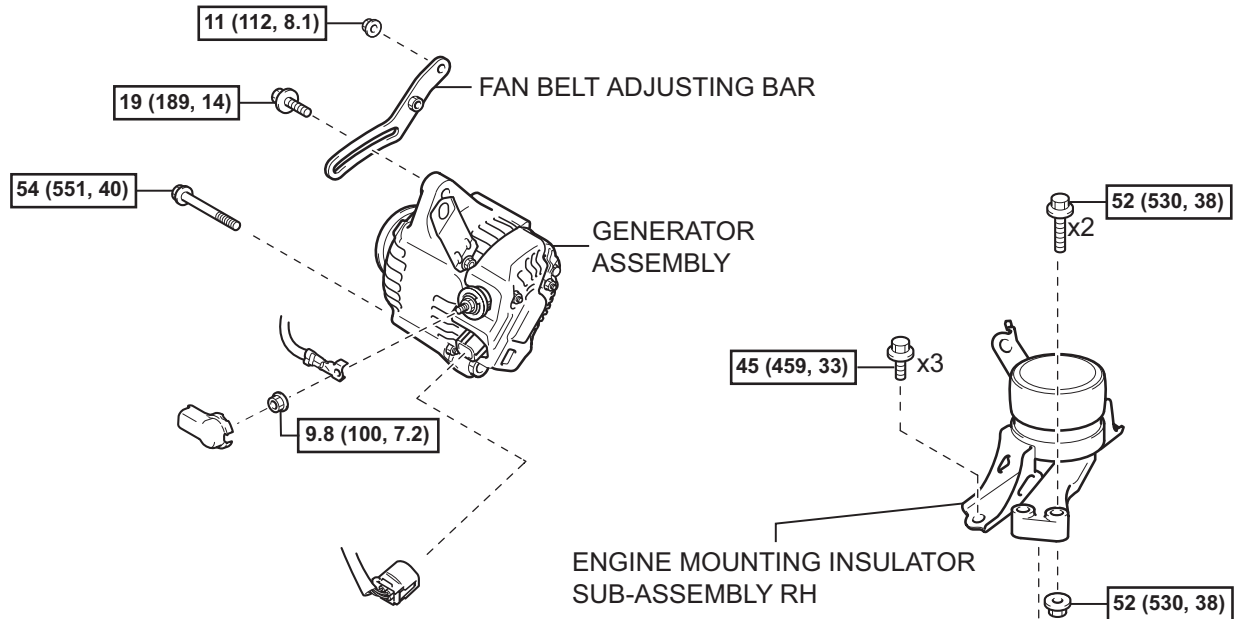

N*m (kgf*cm, ft.*lbf) : Specified torque

T

EM

for Sedan:

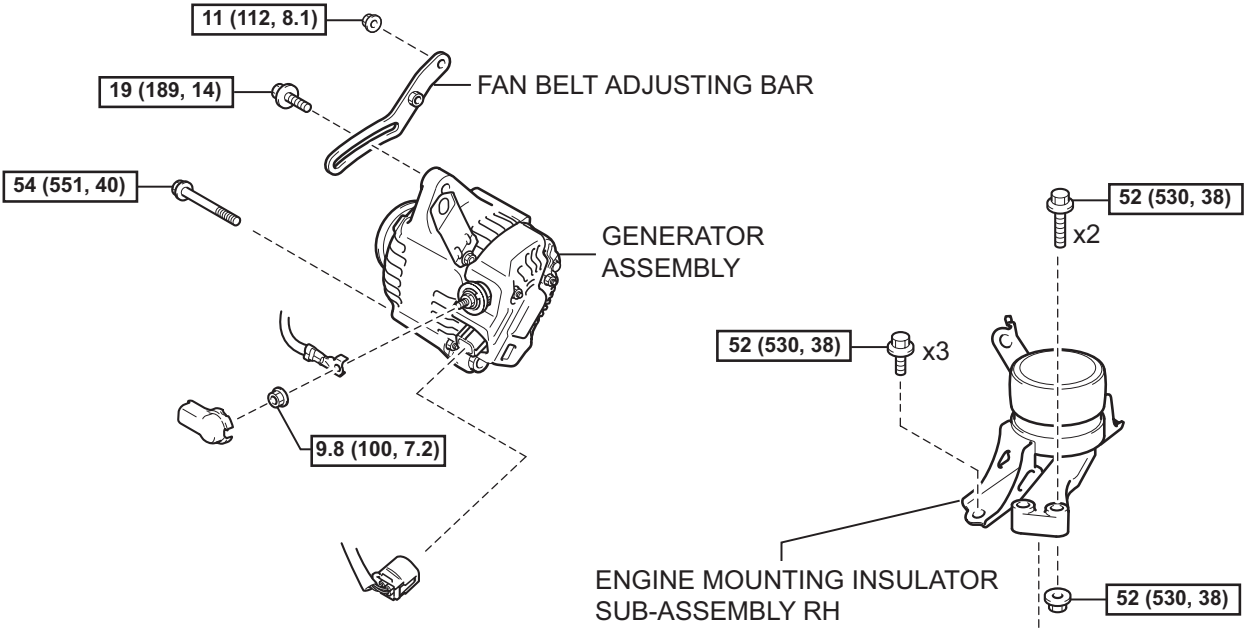

EM

N*m (kgf*cm, ft*lbf) : Specified torque

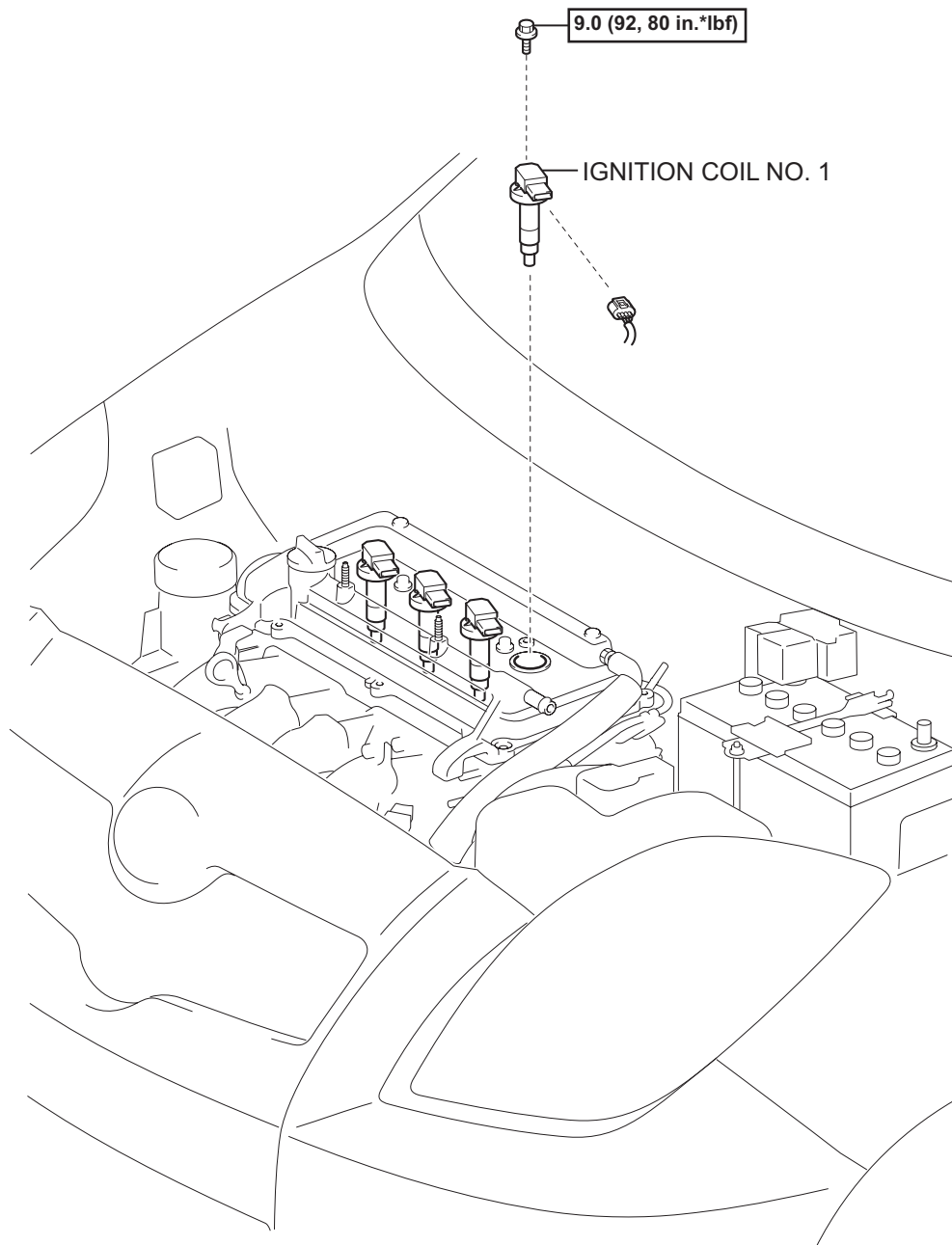

N*m (kgf*cm, ft.*lbf) : Specified torque

EM

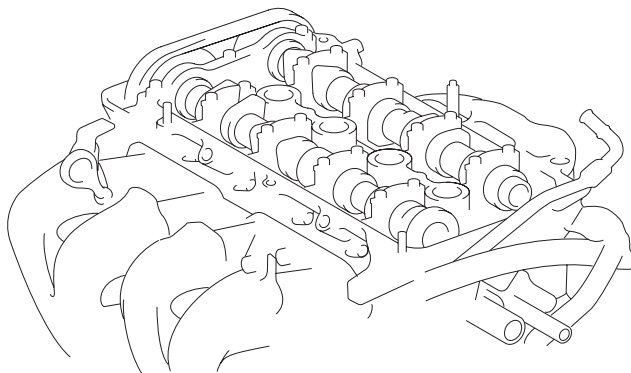
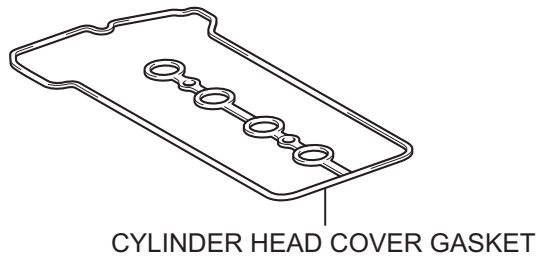
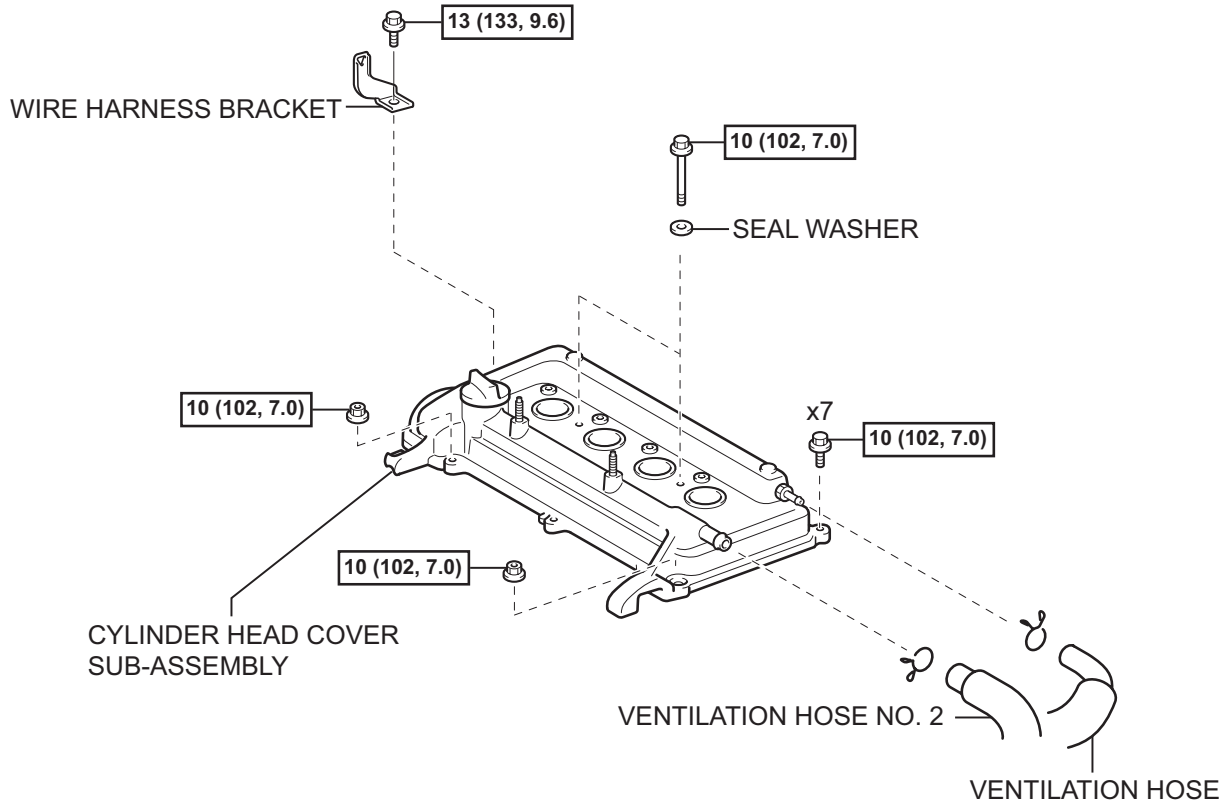

N*m (kgf*cm, ft.*lbf) : Specified torque

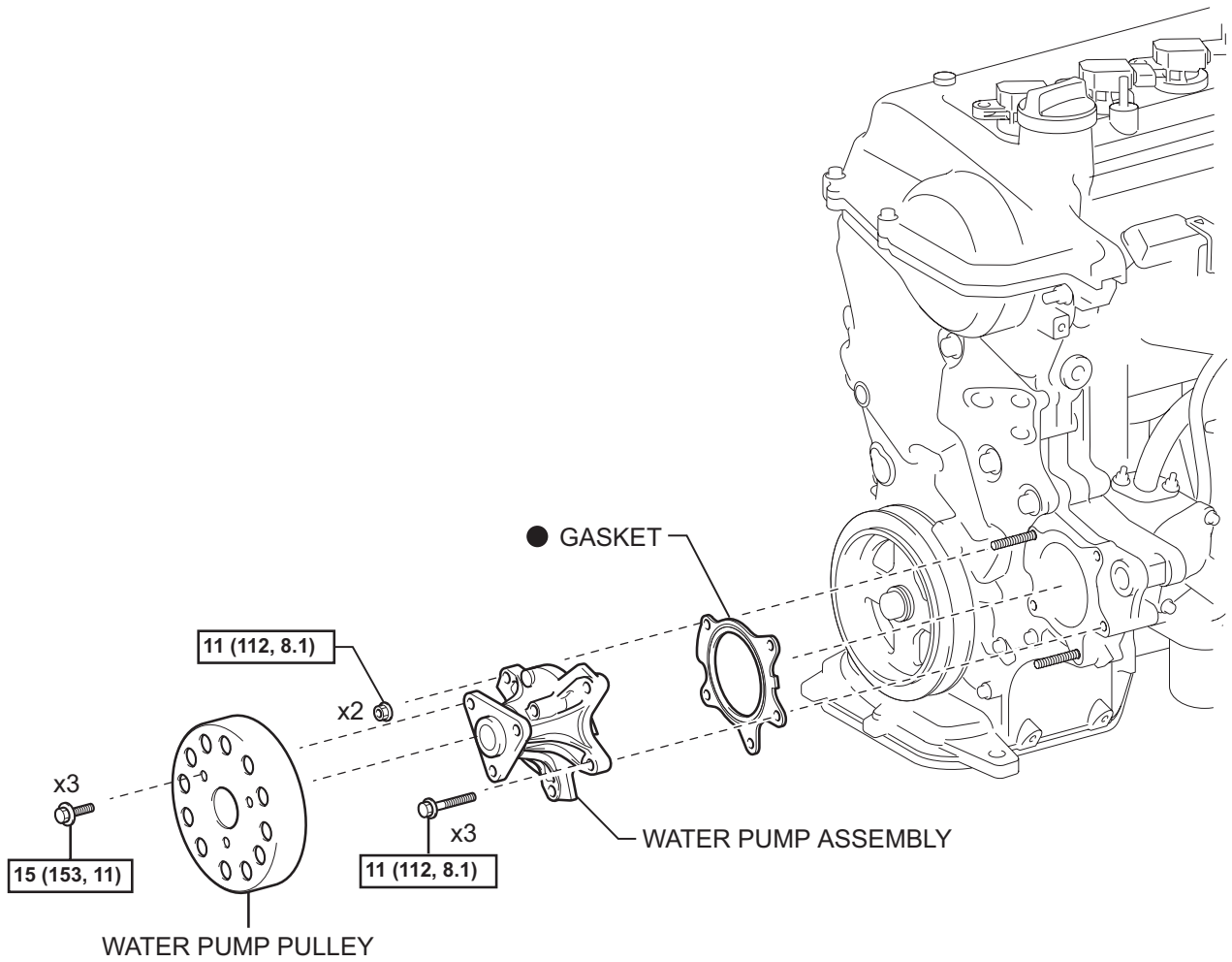

[N*m (kgf*cm, ft.*lbf)] : Specified torque

● Non-reusable part

T

EM

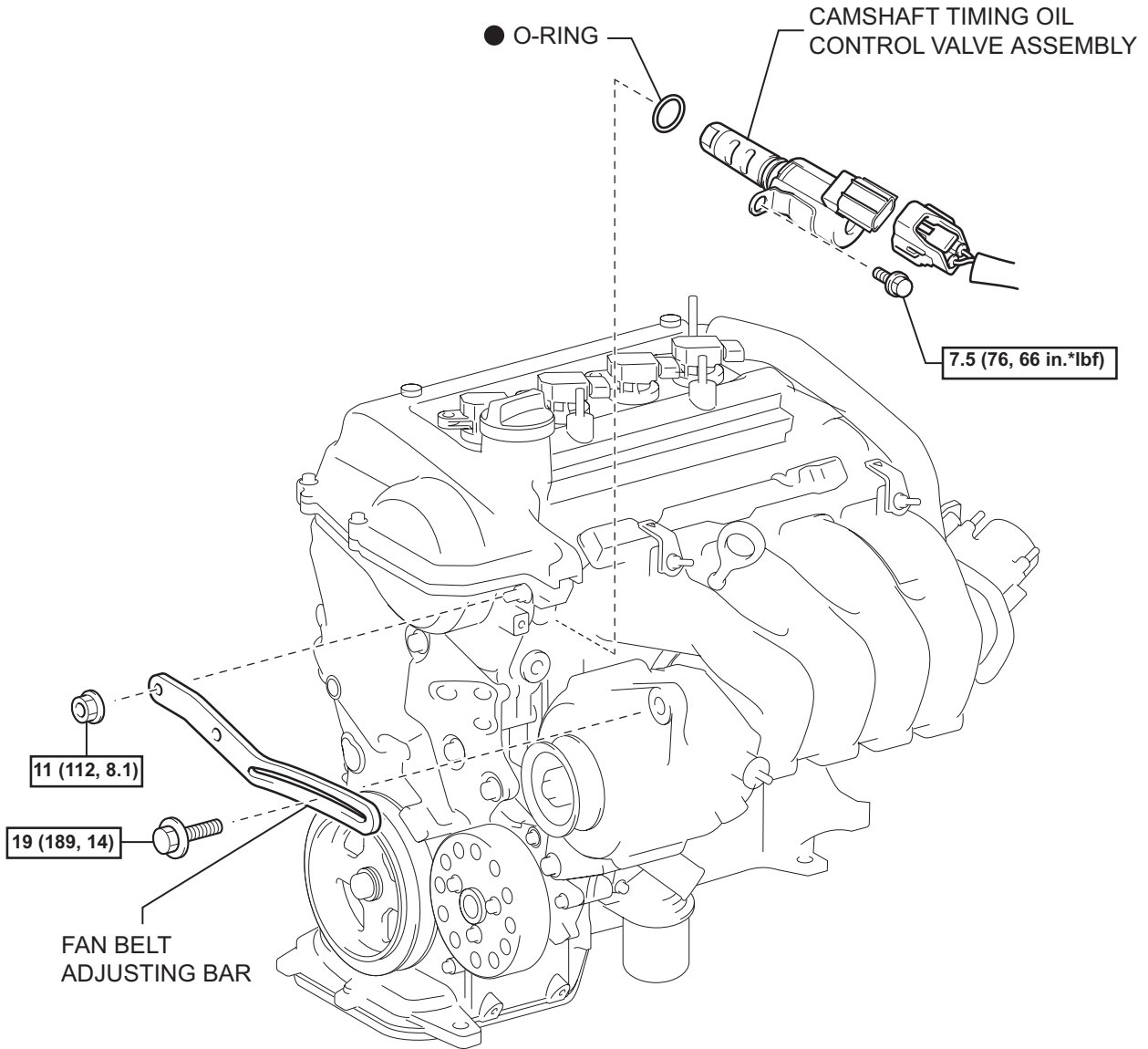

[N*m (kgf*cm, ft.*lbf)] : Specified torque

● Non-reusable part

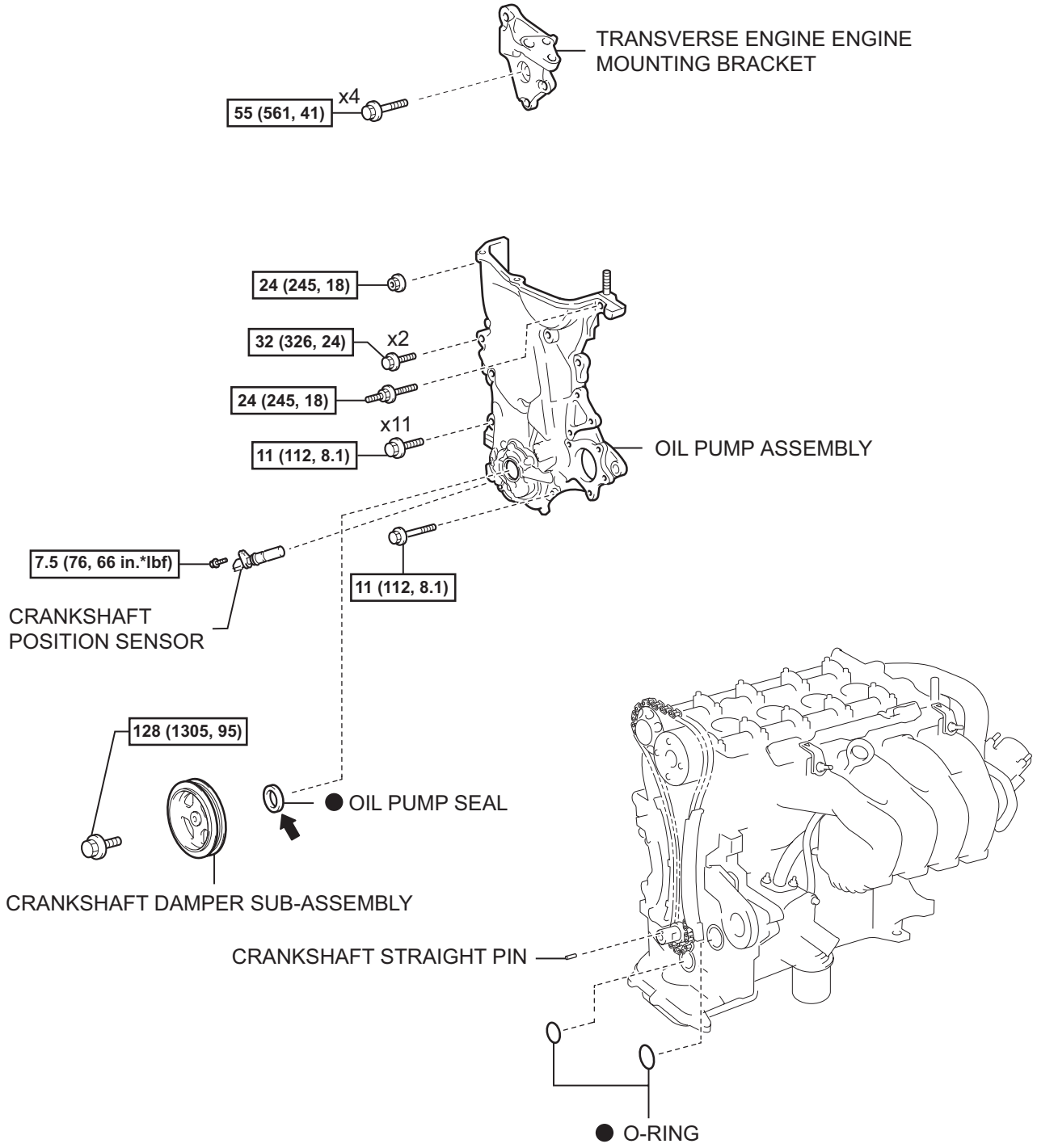

N*m (kgf*cm, ft.*lbf) : Specified torque

● Non-reusable part ← Apply MP grease

EM

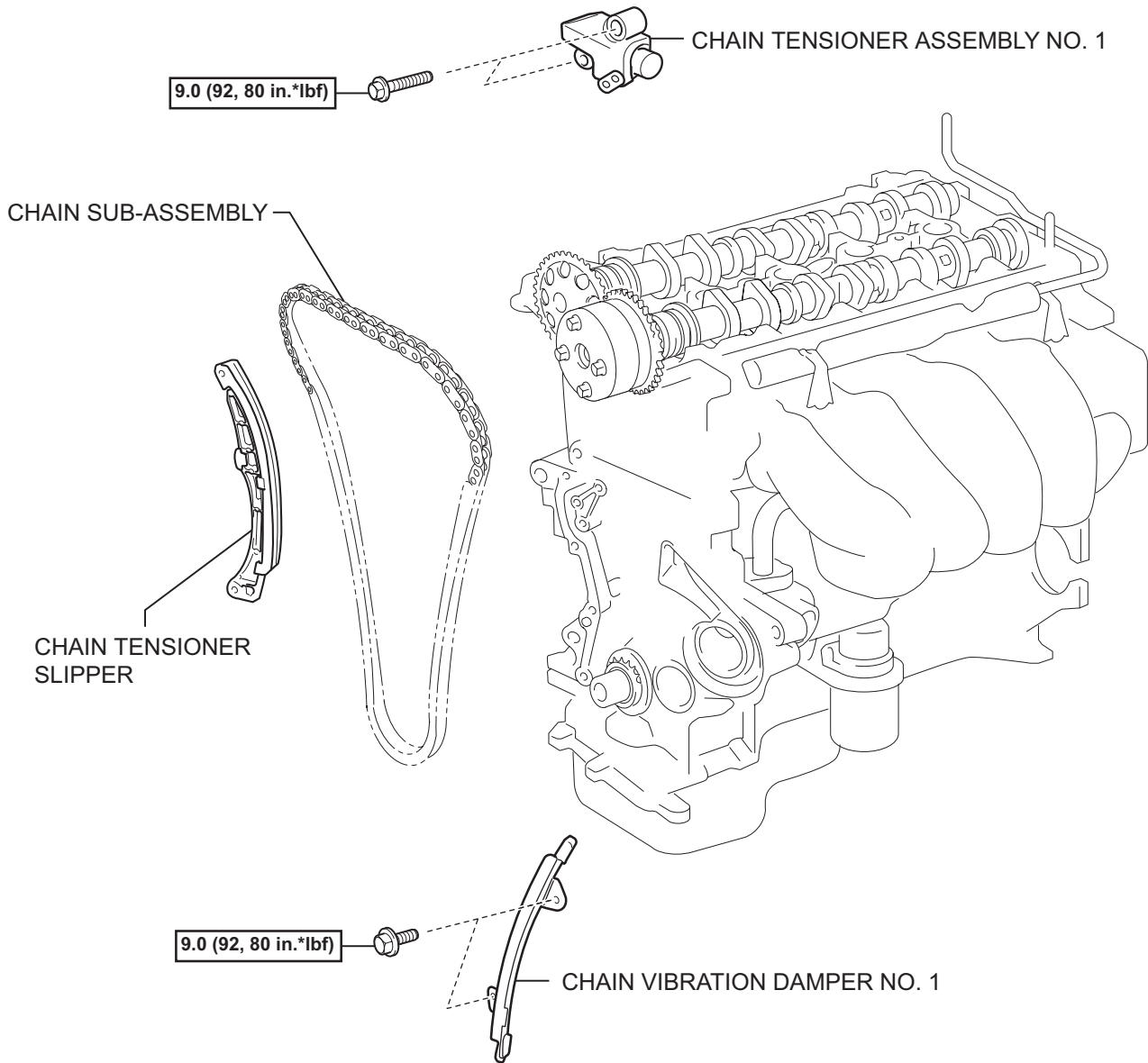

N*m (kgf*cm, ft.*lbf) : Specified torque

REMOVAL

1. DISCONNECT CABLE FROM NEGATIVE BATTERY TERMINAL
2. REMOVE FRONT WHEEL RH
3. REMOVE ENGINE UNDER COVER RH
4. DRAIN ENGINE OIL
5. DRAIN ENGINE COOLANT (See page [CO-8](#))
6. REMOVE CYLINDER HEAD COVER NO. 2 (See page [IG-9](#))
7. REMOVE FAN AND GENERATOR V BELT (See page [EM-7](#))
8. REMOVE GENERATOR ASSEMBLY (See page [CH-10](#))
9. REMOVE IGNITION COIL NO. 1 (See page [IG-9](#))
10. DISCONNECT VENTILATION HOSE (See page [FU-13](#))
11. DISCONNECT VENTILATION HOSE NO. 2 (See page [FU-13](#))
12. REMOVE CYLINDER HEAD COVER SUB-ASSEMBLY (See page [FU-13](#))
13. REMOVE ENGINE MOUNTING INSULATOR SUB-ASSEMBLY RH (See page [LU-17](#))
14. REMOVE CRANKSHAFT DAMPER SUB-ASSEMBLY (See page [LU-18](#))
15. REMOVE CRANKSHAFT POSITION SENSOR (See page [ES-403](#))
16. REMOVE CAMSHAFT TIMING OIL CONTROL VALVE ASSEMBLY (See page [ES-396](#))
17. REMOVE WATER PUMP PULLEY (See page [CO-15](#))
18. REMOVE WATER PUMP ASSEMBLY (See page [CO-15](#))
19. REMOVE TRANSVERSE ENGINE ENGINE MOUNTING BRACKET (See page [LU-18](#))
20. REMOVE OIL PUMP ASSEMBLY (See page [LU-19](#))
21. REMOVE OIL PUMP SEAL (See page [LU-21](#))
22. REMOVE CHAIN TENSIONER ASSEMBLY NO. 1
NOTICE:
 - Do not rotate the crankshaft with the chain tensioner removed.
 - When rotating the camshaft with the timing chain removed, rotate the crankshaft counterclockwise 40° from the TDC first.

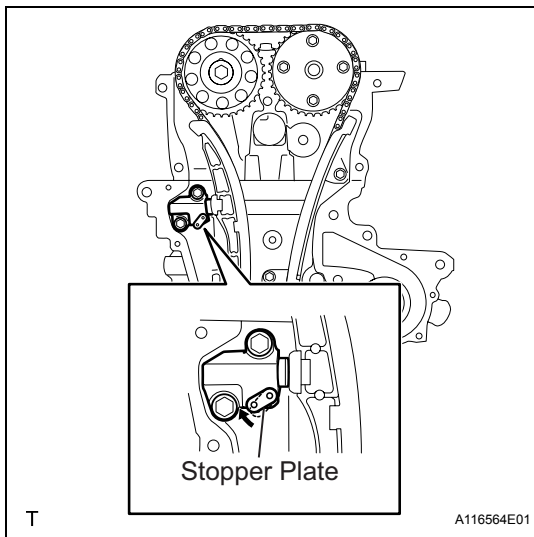

- (a) Pull up the stopper plate and hold it with its lock released.

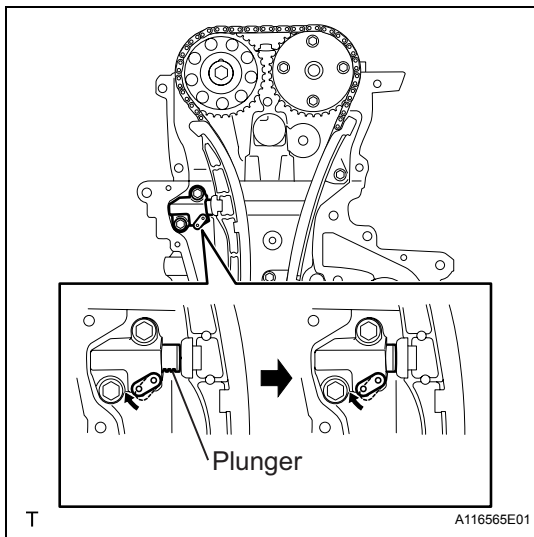

- (b) Unlock the plunger of the tensioner and push it in to the end.

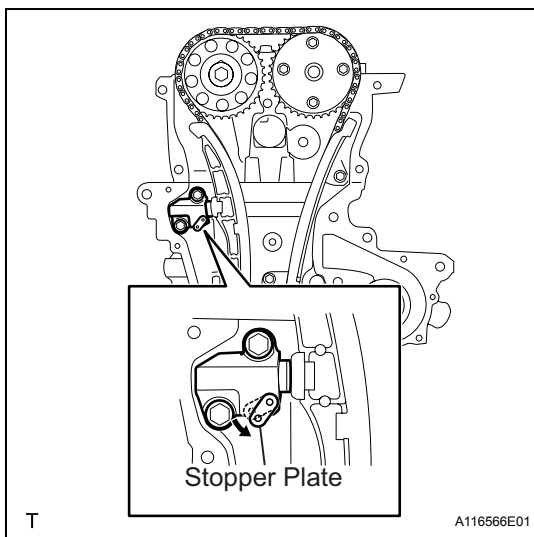

- (c) Pull down the stopper plate with the plunger pushed to the end and lock the plunger.

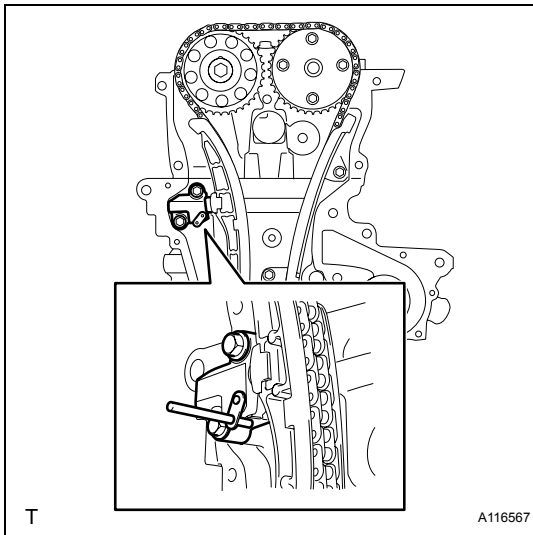

- (d) Insert a 3 mm (0.12 in.) diameter bar into the hole in the stopper plate and lock the plunger.

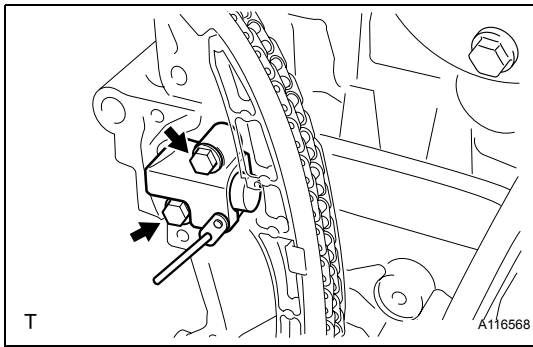

- (e) Remove the 2 bolts and remove chain tensioner assembly No. 1.

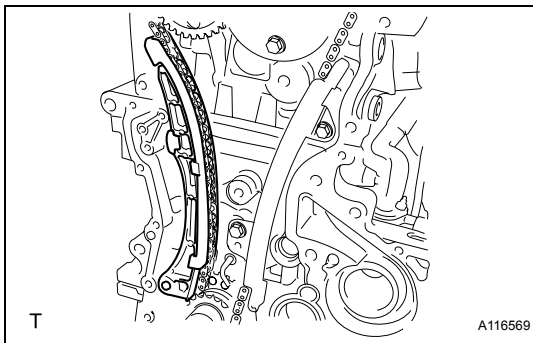

23. REMOVE CHAIN TENSIONER SLIPPER

- (a) Remove the chain tensioner slipper.

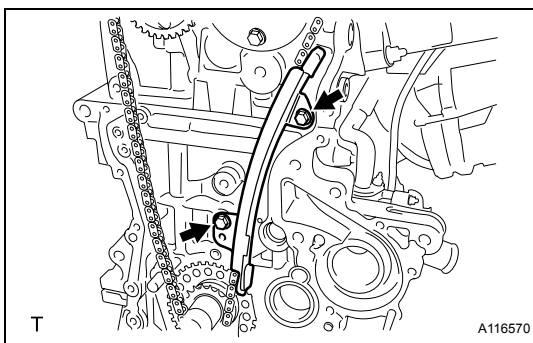

24. REMOVE CHAIN VIBRATION DAMPER NO. 1

- (a) Remove the 2 bolts and remove chain vibration damper No. 1.

25. REMOVE CHAIN SUB-ASSEMBLY

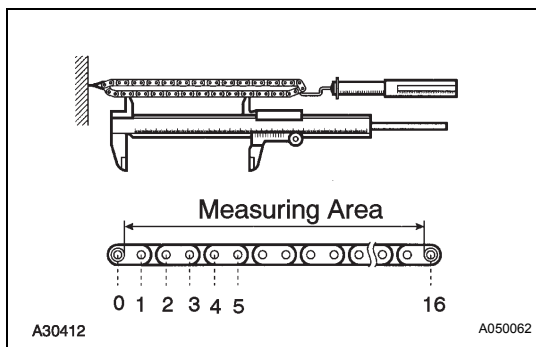

INSPECTION

1. INSPECT CHAIN SUB-ASSEMBLY

- (a) Using a spring scale, apply 140 N (14.3 kgf, 31.5 lb) to the timing chain and measure its length.

Maximum chain elongation:

123.2 mm (4.850 in.)

If the elongation is greater than the maximum, replace the chain.

HINT:

Perform the same measurement at 3 or more random places and calculate the average length.

INSTALLATION

1. INSTALL CHAIN SUB-ASSEMBLY

- (a) Make sure that all the timing marks are in the positions (TDC) shown in the illustration.

HINT:

The positions of the timing marks may differ from the predetermined positions due to the force of the valve spring.

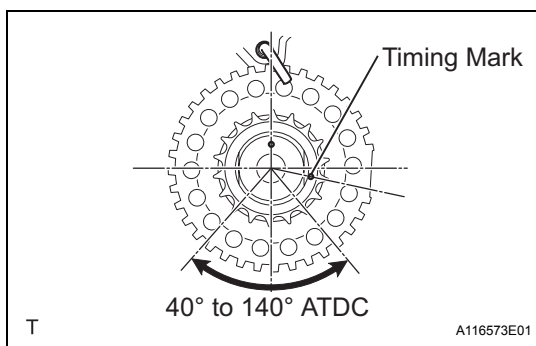
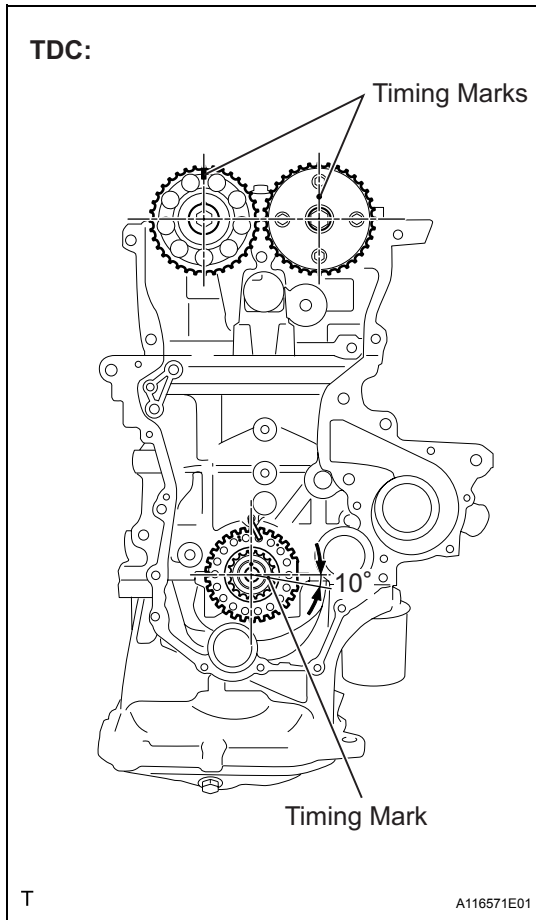

- (b) Set the timing mark of the crankshaft in a position between 40° and 140° ATDC as illustrated.

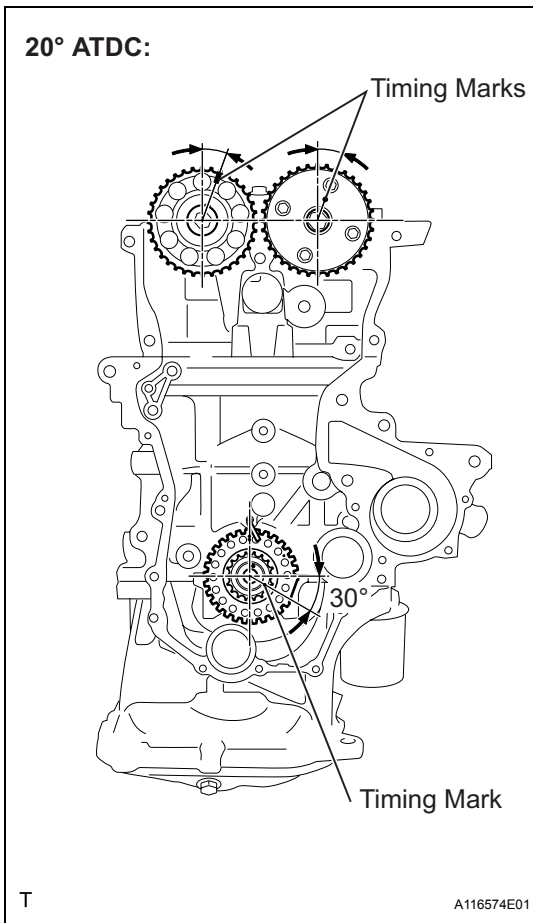

- (c) Set the camshaft timing gear and the camshaft timing sprocket in the positions (20°ATDC) shown in the illustration.
- (d) Set the crankshaft in the position (20°ATDC) shown in the illustration.

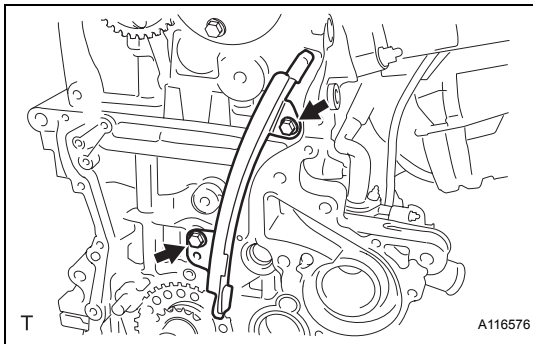

- (e) Install chain vibration damper No. 1 with the 2 bolts.
Torque: 9.0 N*m (92 kgf*cm, 80 in.*lbf)

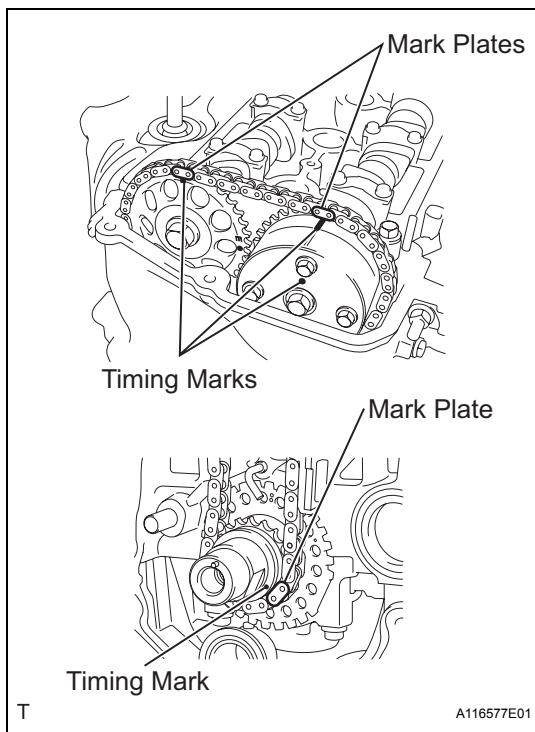

- (f) Align the timing marks of the camshaft with the mark plates of the timing chain and install the timing chain.

HINT:

Align the timing marks with the mark plates while turning the hexagonal service portion of the camshaft using a wrench.

EM

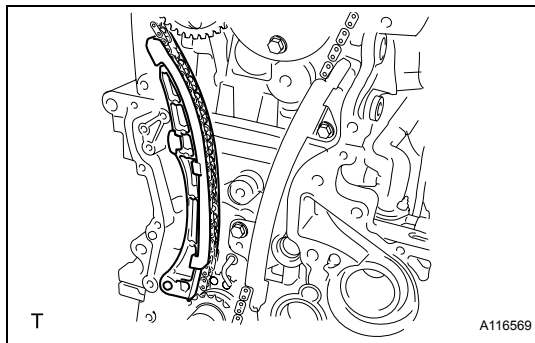

2. INSTALL CHAIN TENSIONER SLIPPER

- (a) Install the chain tensioner slipper.

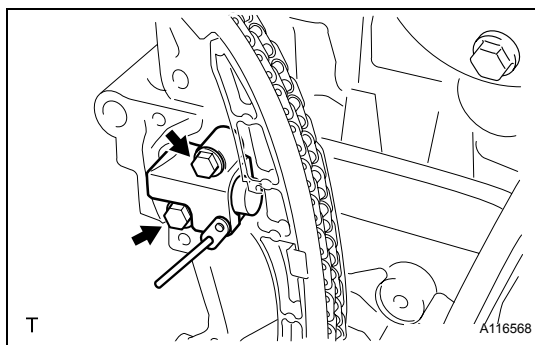

3. INSTALL CHAIN TENSIONER ASSEMBLY NO. 1

- (a) Install chain tensioner assembly No. 1 with the 2 bolts.

Torque: 9.0 N*m (92 kgf*cm, 80 in.*lbf)

- (b) Remove the bar from chain tensioner assembly No. 1.

4. INSTALL OIL PUMP SEAL (See page [LU-21](#))

5. INSTALL OIL PUMP ASSEMBLY (See page [LU-22](#))

6. INSTALL TRANSVERSE ENGINE ENGINE MOUNTING BRACKET (See page [LU-26](#))

7. INSTALL WATER PUMP ASSEMBLY (See page [CO-16](#))

8. INSTALL WATER PUMP PULLEY (See page [CO-16](#))

9. INSTALL CAMSHAFT TIMING OIL CONTROL VALVE ASSEMBLY (See page [ES-397](#))

10. INSTALL CRANKSHAFT POSITION SENSOR (See page [ES-403](#))

11. INSTALL CRANKSHAFT DAMPER SUB-ASSEMBLY
(See page [LU-26](#))
12. INSTALL ENGINE MOUNTING INSULATOR SUB-ASSEMBLY RH (See page [LU-26](#))
13. INSTALL CYLINDER HEAD COVER SUB-ASSEMBLY
(See page [FU-19](#))
14. CONNECT VENTILATION HOSE NO. 2 (See page [FU-20](#))
15. CONNECT VENTILATION HOSE (See page [FU-20](#))
16. INSTALL IGNITION COIL NO. 1 (See page [IG-9](#))
17. INSTALL GENERATOR ASSEMBLY (See page [CH-17](#))
18. INSTALL FAN AND GENERATOR V BELT (See page [EM-7](#))
19. ADJUST FAN AND GENERATOR V BELT (See page [EM-7](#))
20. INSPECT FAN AND GENERATOR V BELT (See page [EM-8](#))
21. CONNECT CABLE TO NEGATIVE BATTERY TERMINAL
Torque: 5.4 N*m (55 kgf*cm, 48 in.*lbf)
22. ADD ENGINE OIL
23. ADD ENGINE COOLANT (See page [CO-8](#))
24. CHECK ENGINE OIL LEVEL (See page [LU-1](#))
25. CHECK FOR ENGINE OIL LEAKAGE
26. CHECK FOR ENGINE COOLANT LEAKAGE (See page [CO-1](#))
27. INSTALL CYLINDER HEAD COVER NO. 2 (See page [IG-10](#))
28. INSTALL ENGINE UNDER COVER RH
29. INSTALL FRONT WHEEL RH
Torque: 103 N*m (1050 kgf*cm, 76 ft.*lbf)

CAMSHAFT COMPONENTS

EM

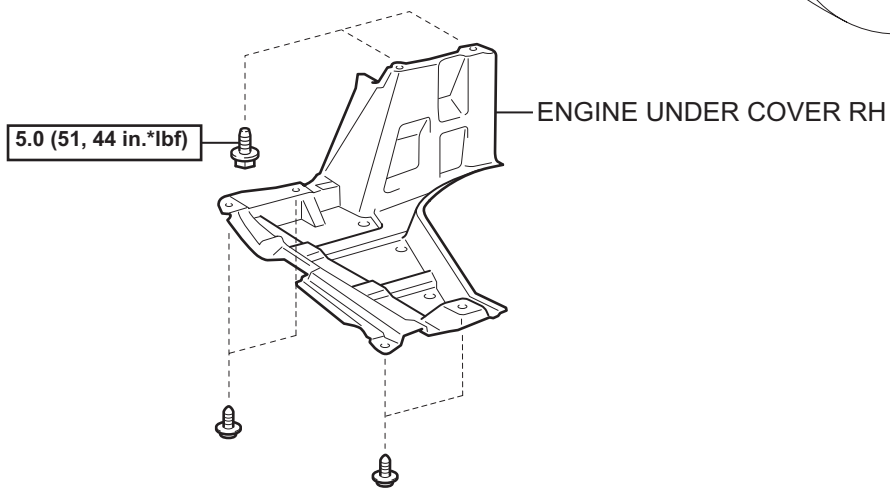
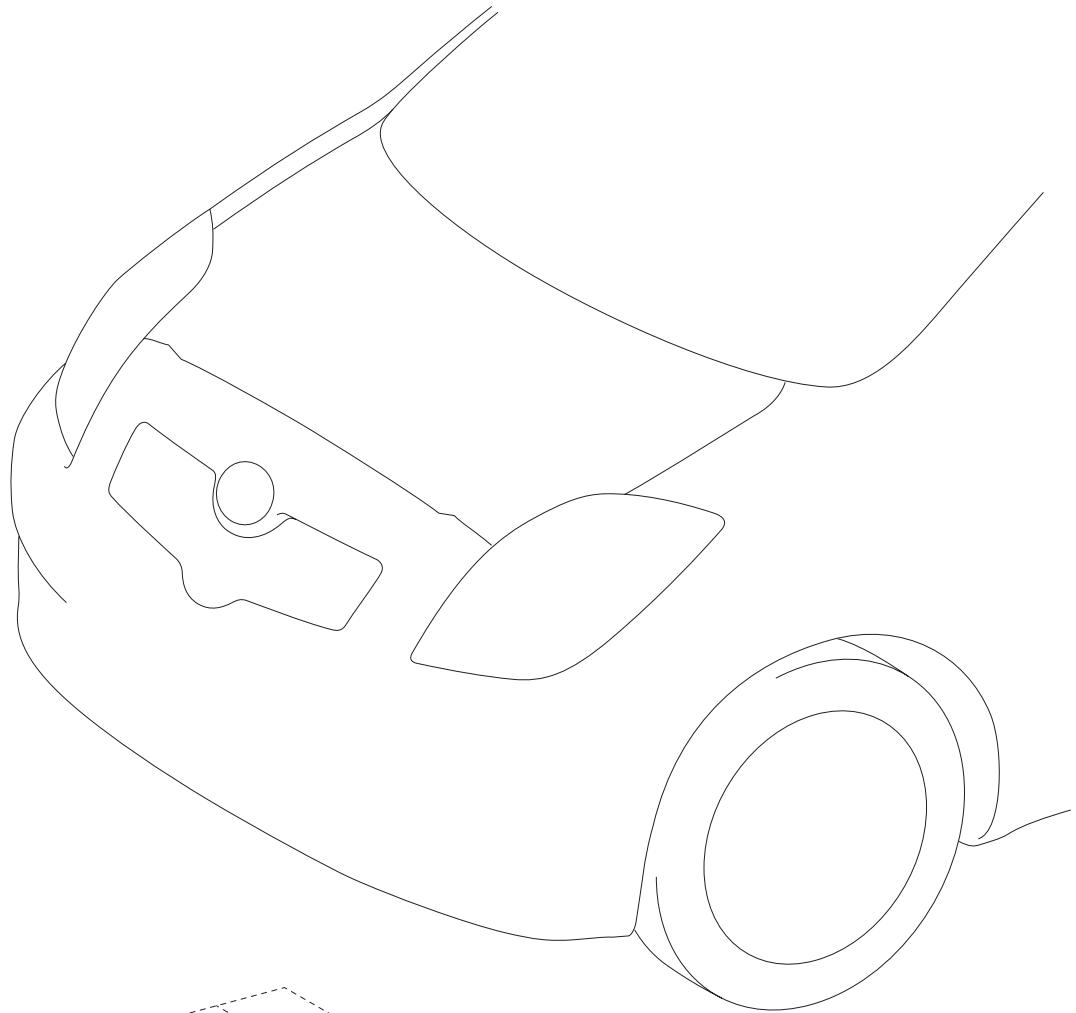

N*m (kgf*cm, ft.*lbf) : Specified torque

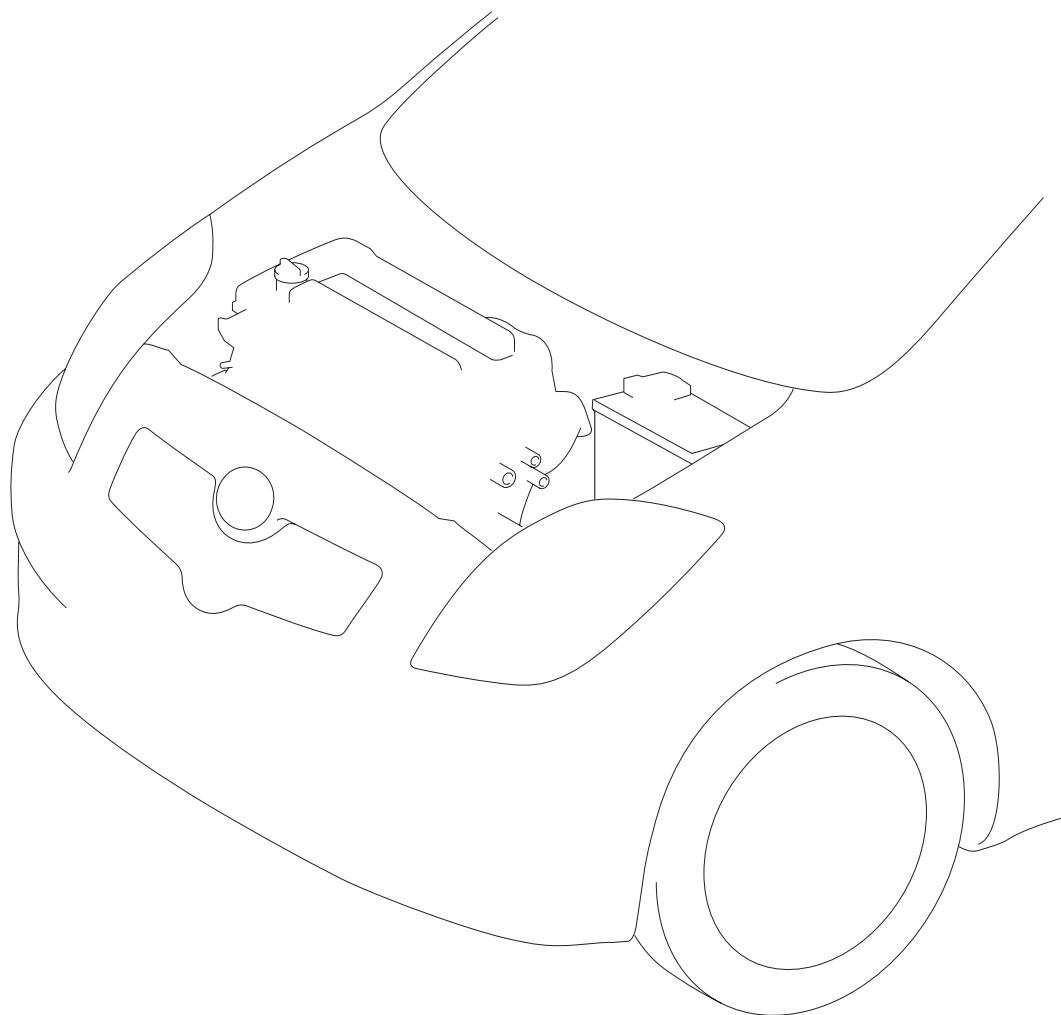
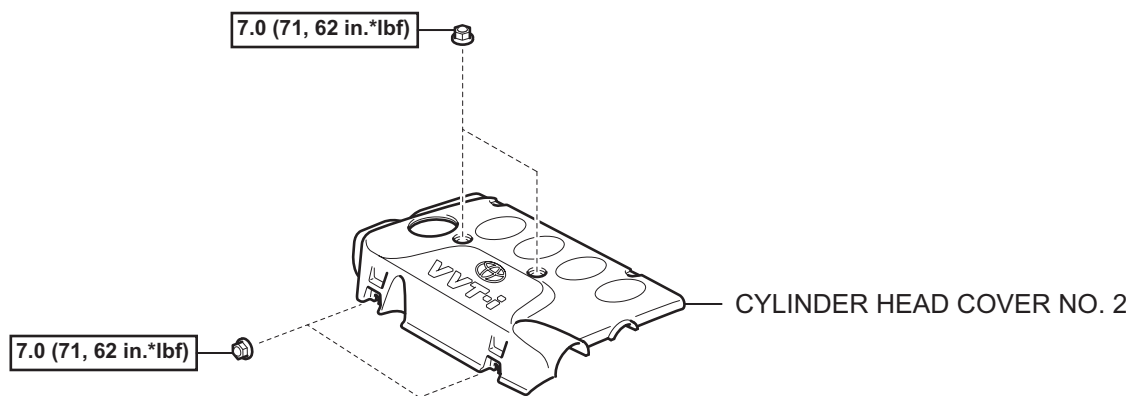

N*m (kgf*cm, ft.*lbf) : Specified torque

T

EM

for Hatchback:

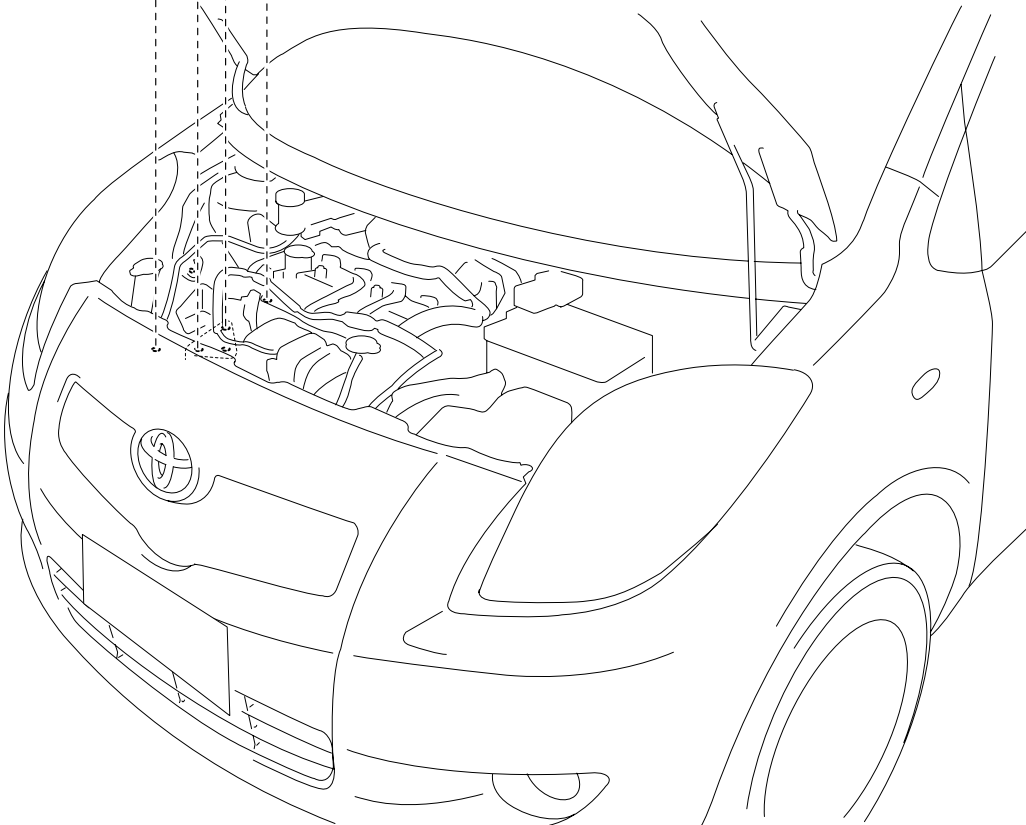
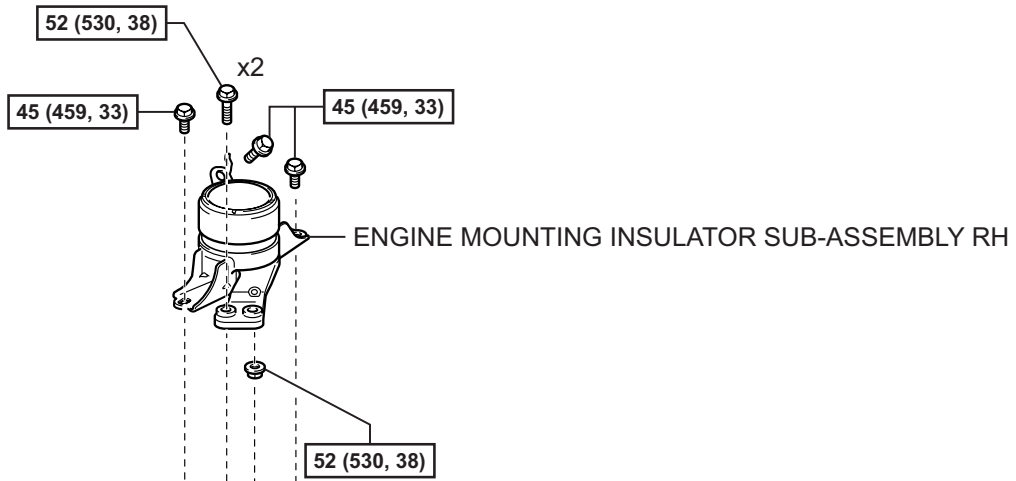

N*m (kgf*cm, ft.*lbf) : Specified torque

for Sedan:

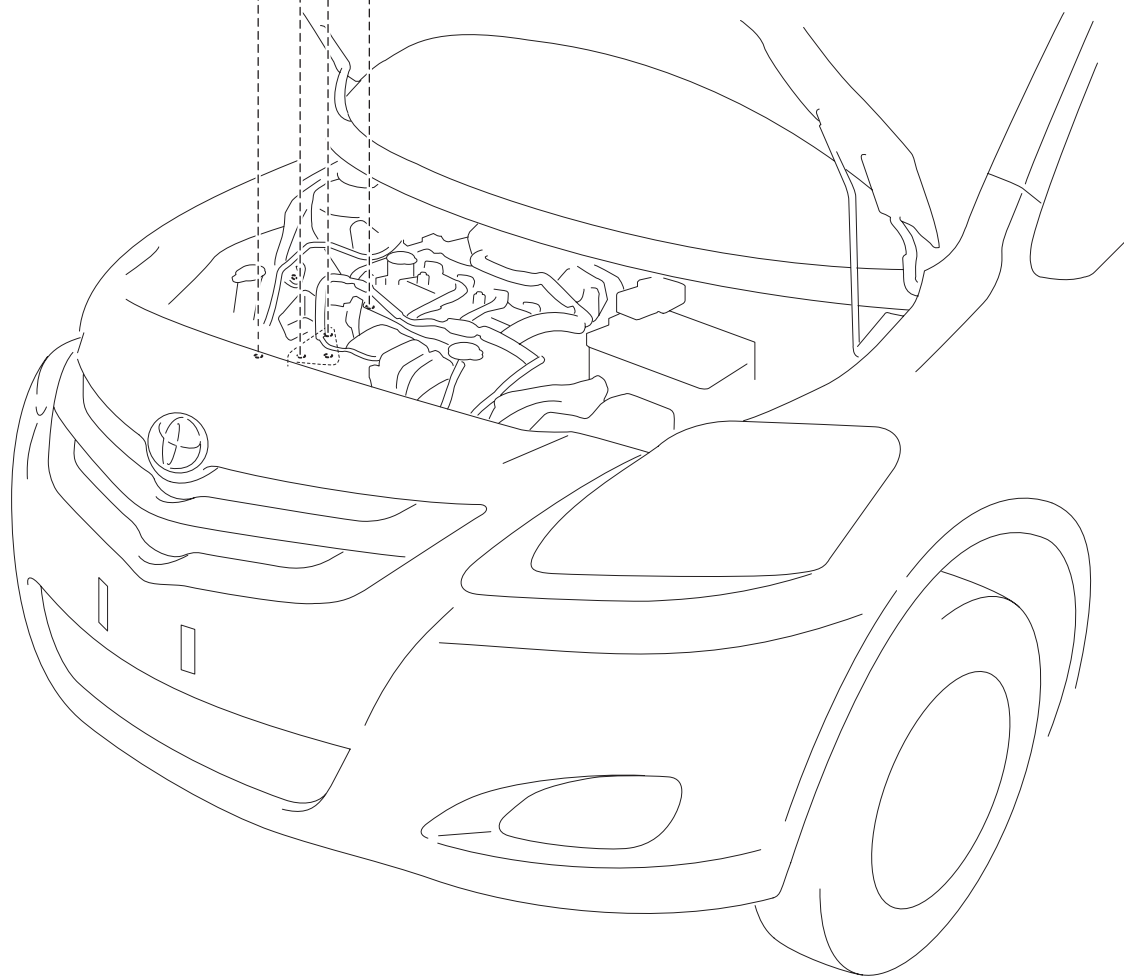
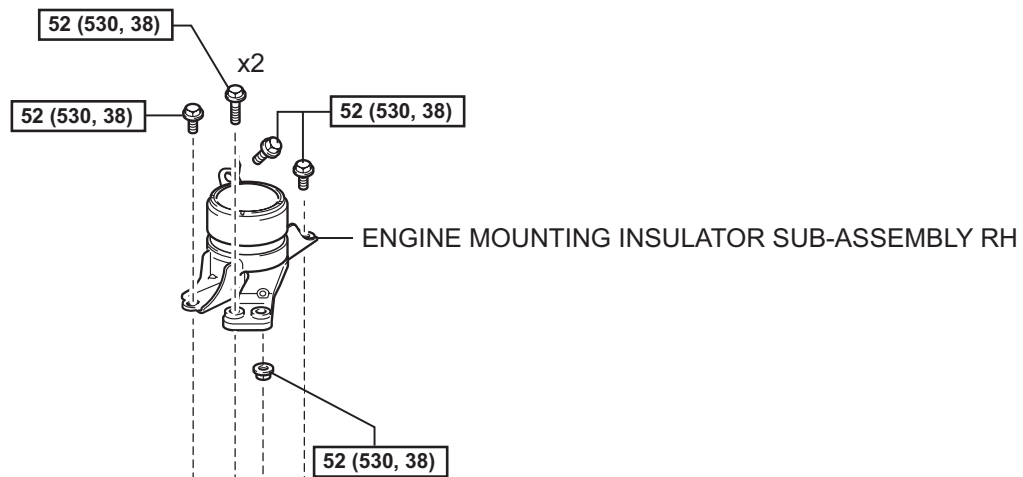

EM

N*m (kgf*cm, ft*lbf) : Specified torque

EM

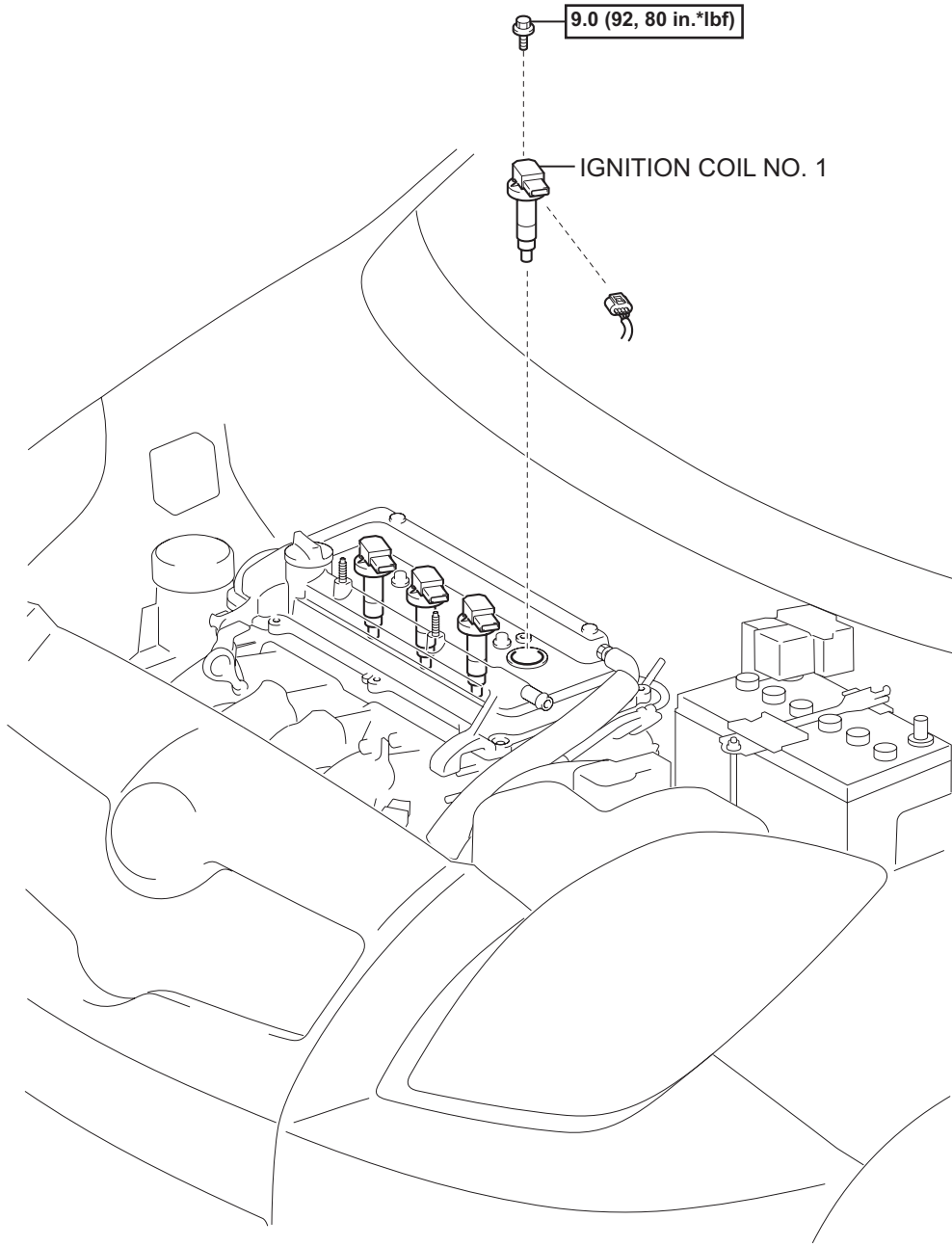

$\boxed{\text{N}^*\text{m (kgf}^*\text{cm, ft.}^*\text{lbf)}}$: Specified torque

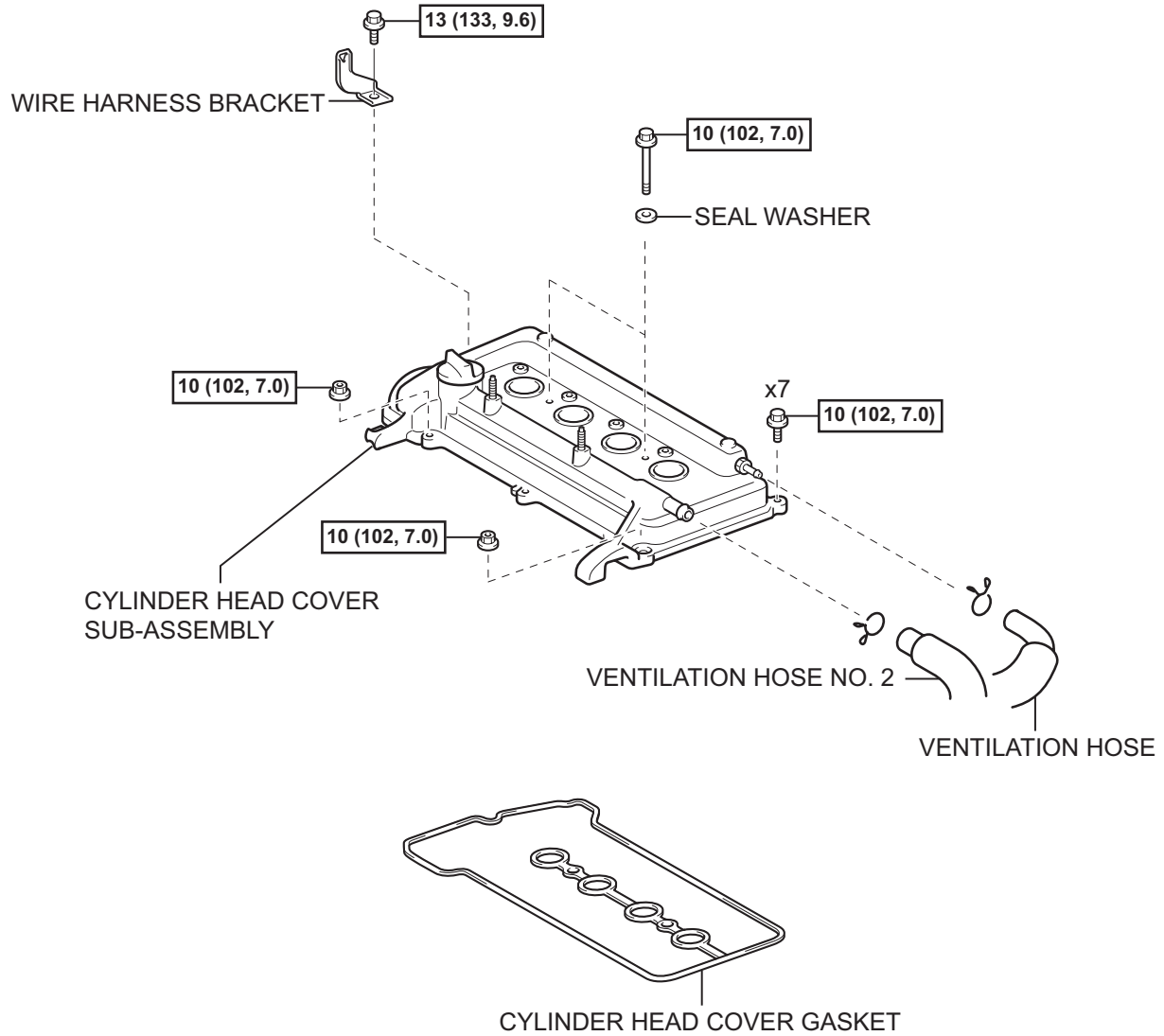

N*m (kgf*cm, ft.*lbf) : Specified torque

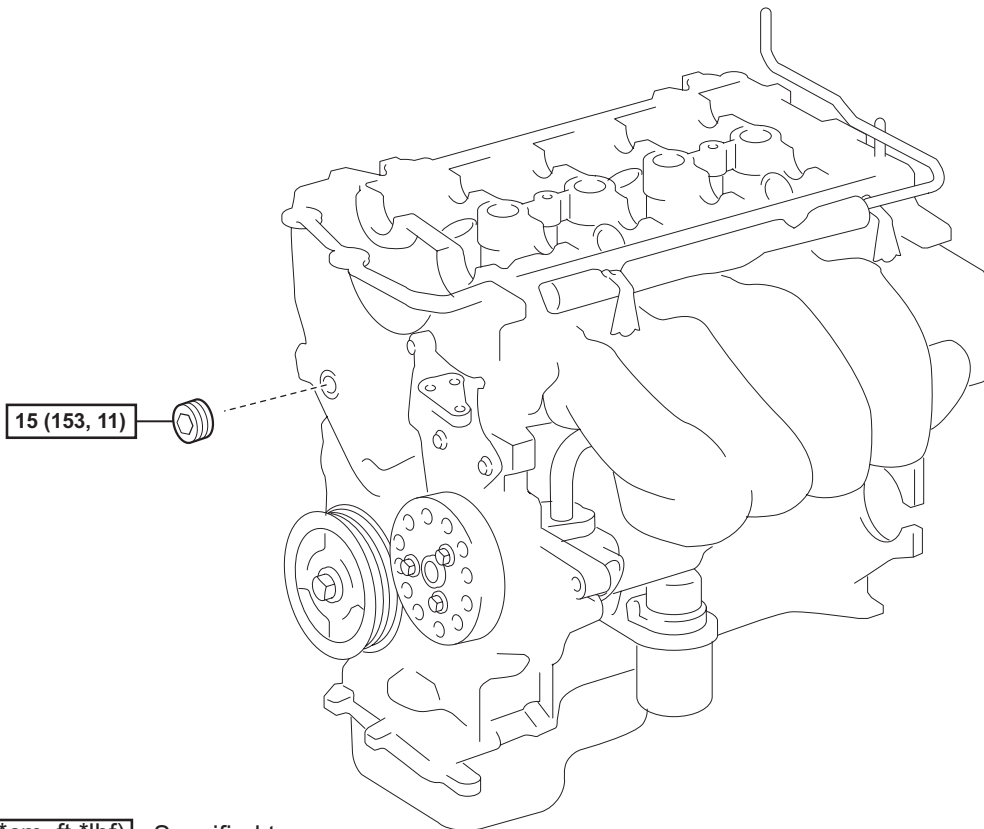
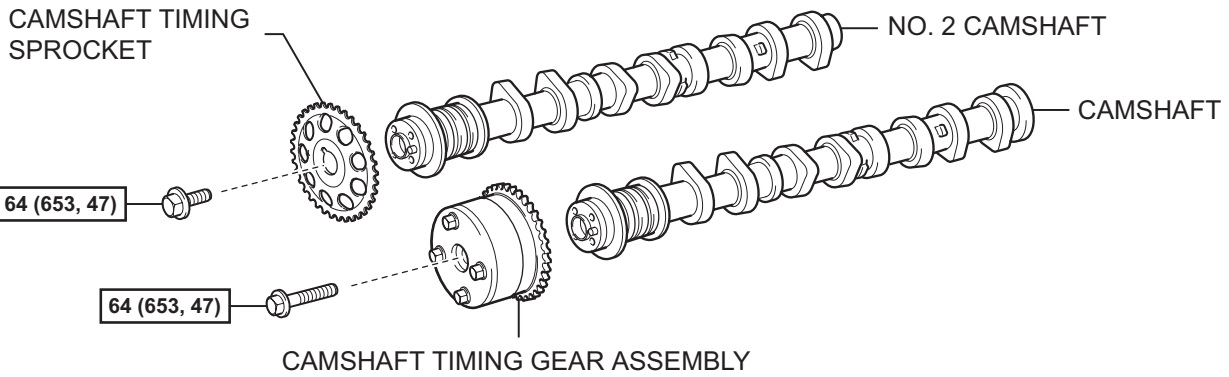
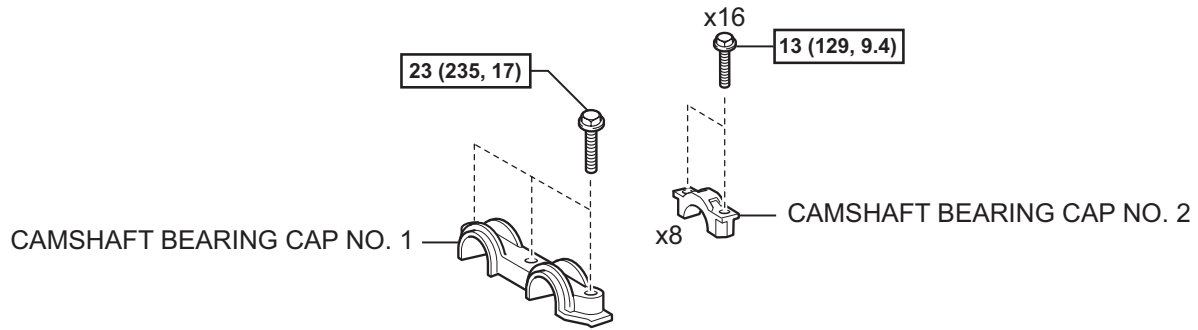

N*m (kgf*cm, ft.*lbf) : Specified torque

EM

REMOVAL

1. DISCONNECT CABLE FROM NEGATIVE BATTERY TERMINAL
2. REMOVE ENGINE UNDER COVER RH
3. REMOVE CYLINDER HEAD COVER NO. 2 (See page [IG-9](#))
4. REMOVE IGNITION COIL NO. 1 (See page [IG-9](#))
5. DISCONNECT VENTILATION HOSE (See page [FU-13](#))
6. DISCONNECT VENTILATION HOSE NO. 2 (See page [FU-13](#))
7. REMOVE CYLINDER HEAD COVER SUB-ASSEMBLY (See page [FU-13](#))
8. REMOVE FAN AND GENERATOR V BELT (See page [EM-7](#))
9. REMOVE ENGINE MOUNTING INSULATOR SUB-ASSEMBLY RH (See page [LU-17](#))
10. REMOVE NO. 2 CAMSHAFT

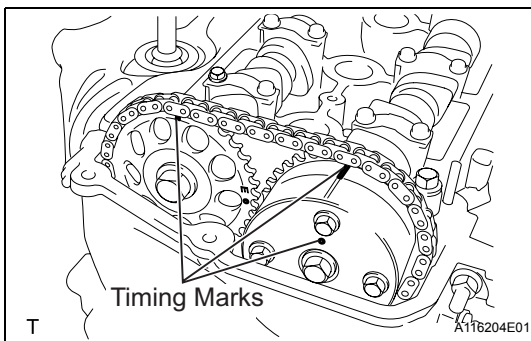
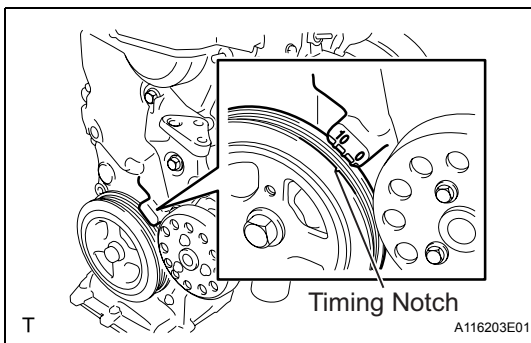
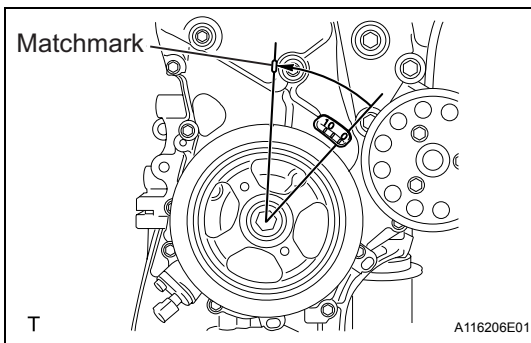

NOTICE:

When rotating the camshaft with the timing chain removed, rotate the crankshaft damper counterclockwise 40 ° from the TDC and align its timing notch with the matchmark of the timing chain cover to prevent the pistons from coming into contact with the valves.

- (a) Set the No. 1 cylinder to TDC / compression.
 - (1) Turn the crankshaft damper, and align its timing notch with the timing mark "0" of the oil pump.

- (2) Check that the timing marks on both the camshaft timing sprocket and the camshaft timing gear are facing upward, as shown in the illustration.

HINT:

If not, turn the crankshaft 1 complete revolution (360°) and align the marks as above.

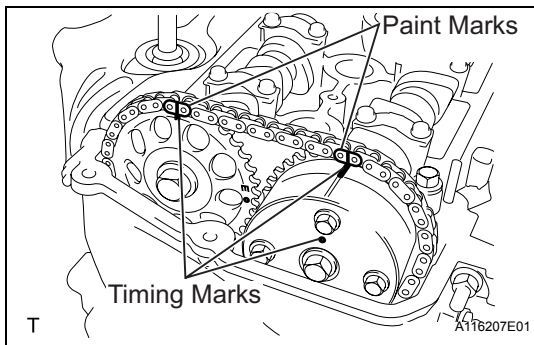

- (b) Place paint marks on the chain in the places where the timing marks of the camshaft timing sprocket and the camshaft timing gear are located.

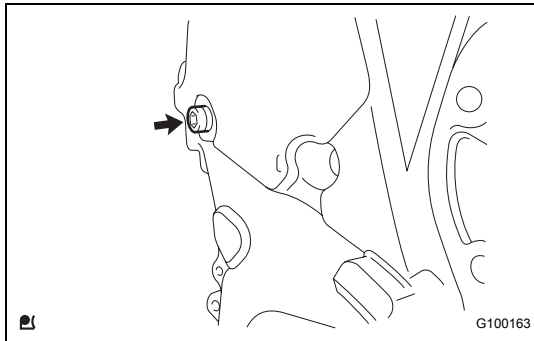

- (c) Using an 8 mm hexagon wrench, remove the screw plug.

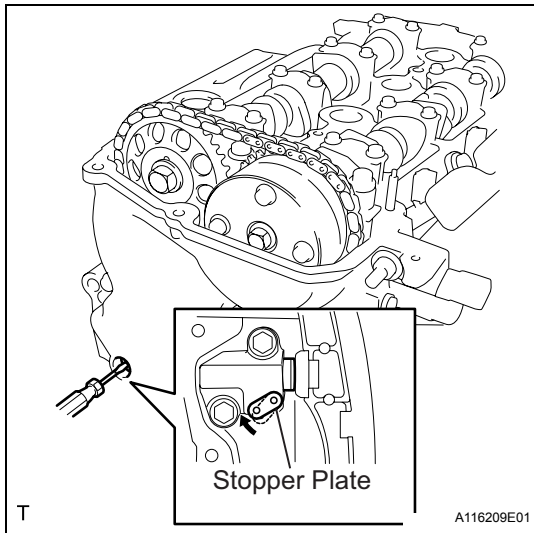

- (d) Insert a screwdriver into the service hole in the chain tensioner to pull the stopper plate of the chain tensioner upward.

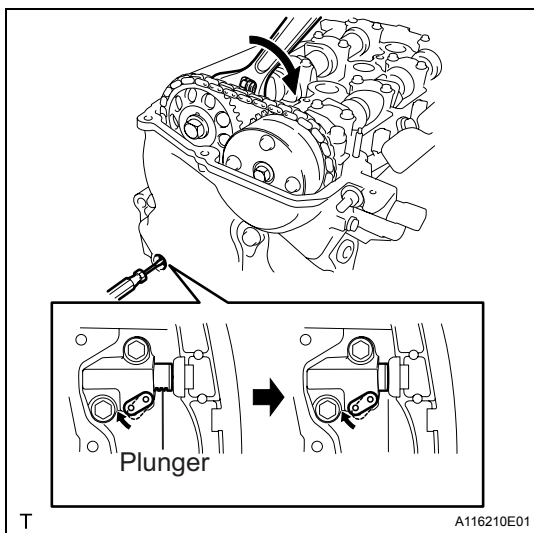

- (e) Using a wrench, rotate camshaft No. 2 clockwise to push in the plunger of the chain tensioner.

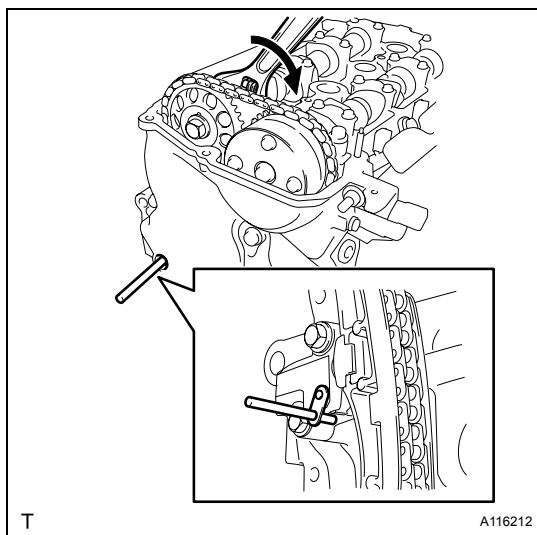

- (f) Remove the screwdriver from the service hole, then align the hole in the stopper plate with the service hole and insert a 3 mm (0.12 in.) diameter bar into the holes to hold the stopper plate.

HINT:

- Fix the stopper plate using the bar while rotating the camshaft right and left slightly.
- Hold the bar with tape so that it does not come off.

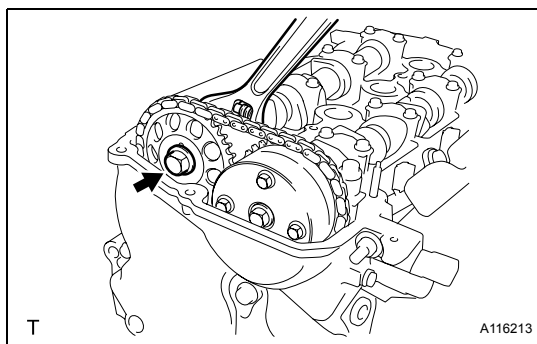

- (g) Using a wrench, hold the hexagonal lobe of camshaft No. 2 and remove the flange bolt.

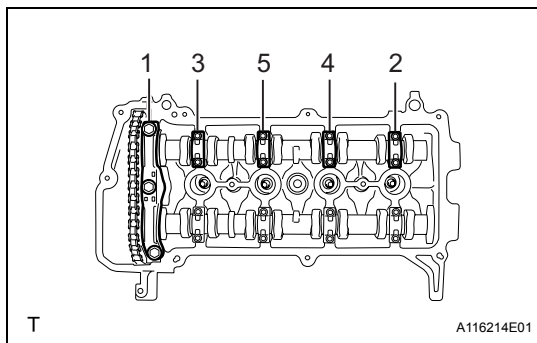

- (h) Using several steps, loosen and remove the 11 bearing cap bolts uniformly in the sequence shown in the illustration, then remove camshaft bearing caps No. 1 and No. 2.

NOTICE:

Loosen the bolts uniformly while keeping the camshaft level.

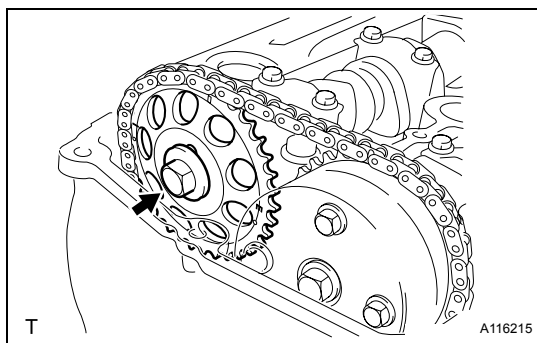

- (i) Remove the flange bolt and remove the camshaft timing sprocket.

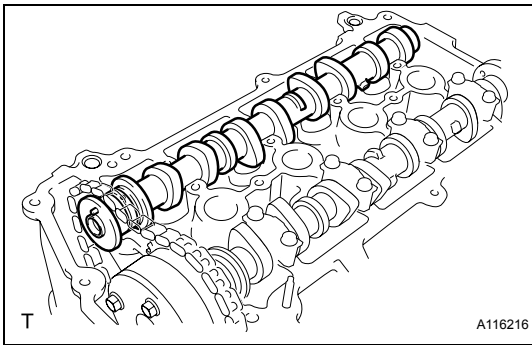

(j) Remove camshaft No. 2.

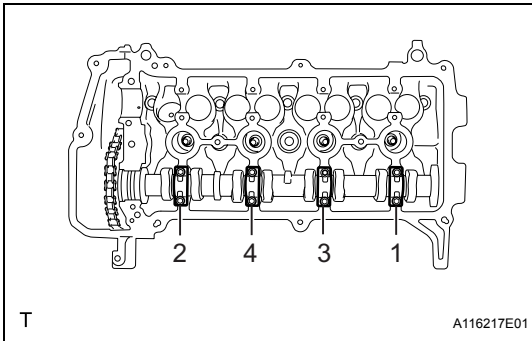

11. REMOVE CAMSHAFT

(a) Using several steps, loosen and remove the 8 bearing cap bolts uniformly in the sequence shown in the illustration, then remove camshaft bearing cap No. 2.

NOTICE:

Loosen each bolt uniformly while keeping the camshaft level.

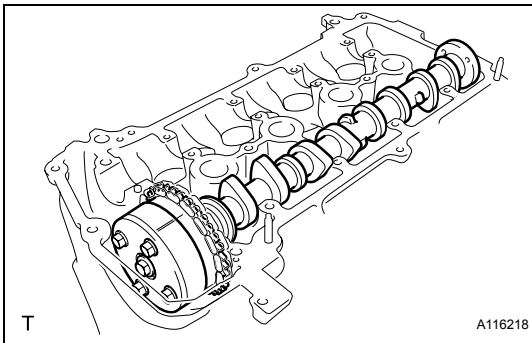

(b) Hold the chain by hand, and remove the camshaft and the camshaft timing gear assembly.

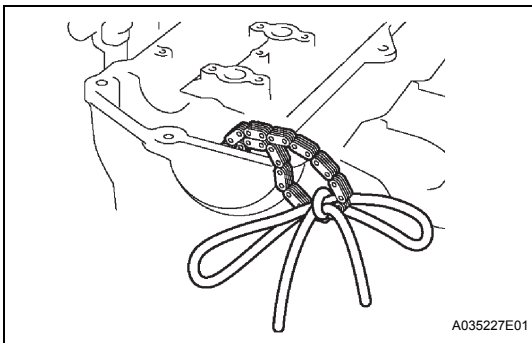

(c) Tie the chain with a piece of string as shown in the illustration.

12. REMOVE CAMSHAFT TIMING GEAR ASSEMBLY

(a) Clamp the camshaft in a vise and confirm that it is locked.

NOTICE:

Do not damage the camshaft.

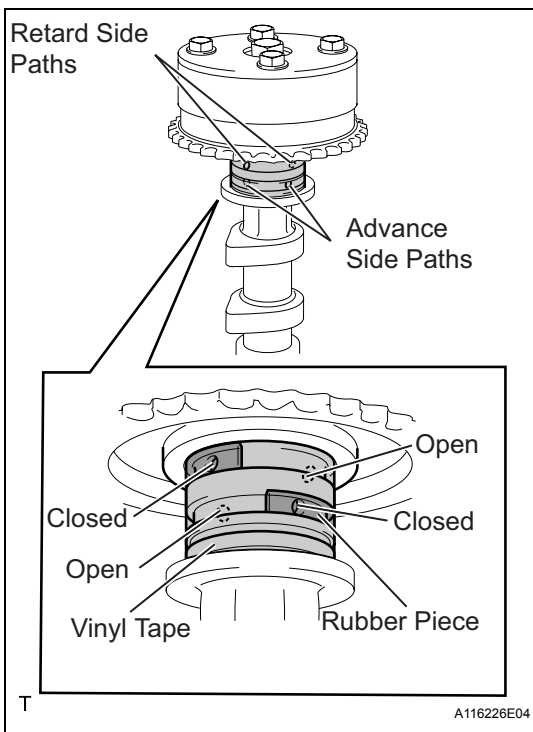

- (b) Cover the 4 oil paths of the cam journal with tape as shown in the illustration.

HINT:

One of the 2 grooves located on the cam journal is for retarding cam timing (upper) and the other is for advancing cam timing (lower). Each groove has 2 oil paths. Plug one of the oil paths for each groove with a piece of rubber before wrapping the cam journal with the tape.

- (c) Puncture the tape covering the advance oil path and the retard oil path on the opposite side from the advance oil path.

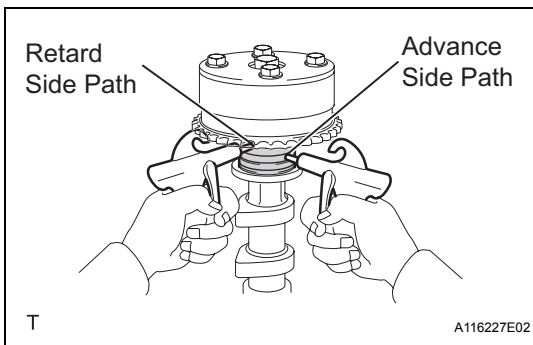

- (d) Apply air at about 150 kPa (1.5 kgf*cm²) pressure into the 2 broken paths (the advance side path and the retard side path).

NOTICE:

Cover the paths with a shop rag or piece of cloth to prevent oil splashes.

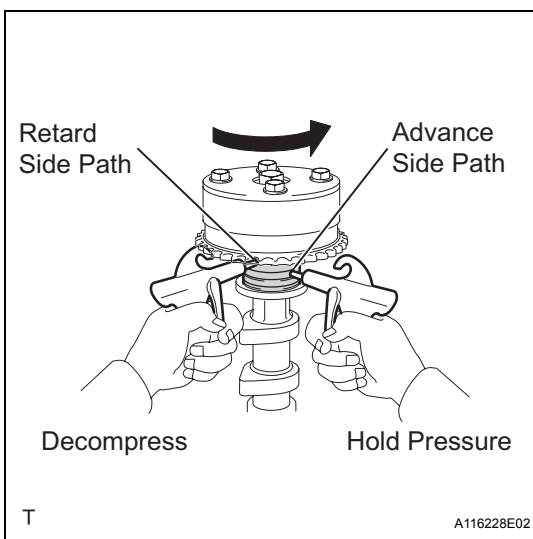

- (e) Confirm that the camshaft timing gear assembly revolves in the timing advance direction when the air pressure on the timing retard path is reduced.

HINT:

The lock pin is released, and the camshaft timing gear revolves in the advance direction.

- (f) When the camshaft timing gear reaches the most advanced position, release the air pressure on the timing retard side path, and then release the air pressure on the timing advance side path.

NOTICE:

The camshaft timing gear assembly occasionally shifts to the retard side abruptly, if the air pressure on the advance side path is released first. This often results in breakage of the lock pin.

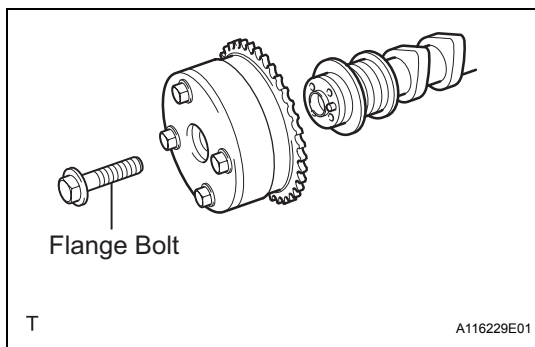

- (g) Remove the flange bolt and remove the camshaft timing gear assembly.

NOTICE:

- Do not remove the other 4 bolts.
- When reusing the camshaft timing gear, unlock the lock pin inside the camshaft timing gear first.

INSPECTION

1. INSPECT CAMSHAFT TIMING GEAR ASSEMBLY

- (a) Check the lock of camshaft timing gear.
 (1) Clamp the camshaft in a vice, and check that the camshaft timing gear is locked.

NOTICE:

Do not damage the camshaft.

- (b) Release the lock pin.

- (1) Cover the 4 oil paths of the cam journal with tape as shown in the illustration.

HINT:

One of the 2 grooves located on the cam journal is for retarding cam timing (upper) and the other is for advancing cam timing (lower). Each groove has 2 oil paths. Plug one of the oil paths for each groove with a piece of rubber before wrapping the cam journal with the tape.

- (2) Puncture the tape covering the advance oil path and the retard oil path on the opposite side from the advance oil path.

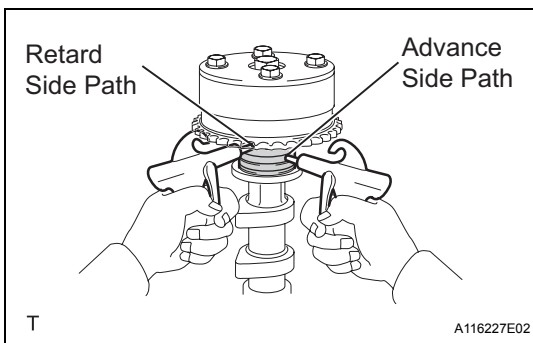
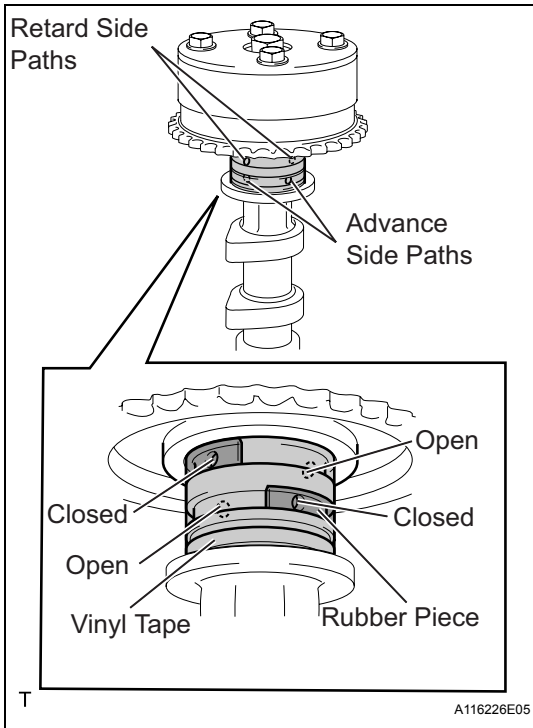

- (3) Apply air at about 150 kPa (1.5kgf*cm²) pressure into the 2 broken paths (the advance side path and the retard side path).

NOTICE:

Cover the paths with a shop rag or piece of cloth to prevent oil splashes.

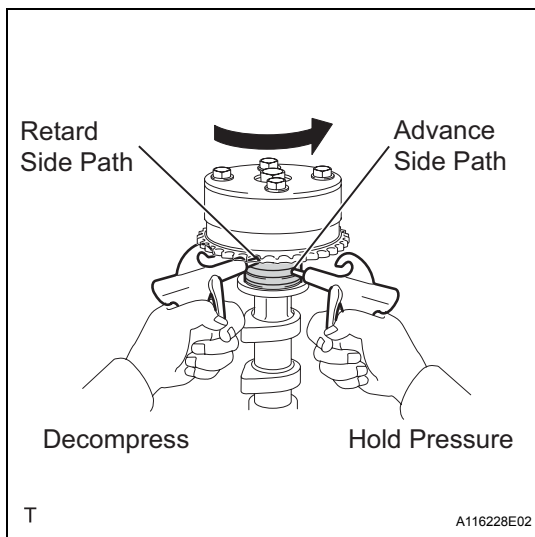

- (4) Confirm that the camshaft timing gear assembly revolves in the timing advance direction when the air pressure on the timing retard path is reduced.

HINT:

The lock pin is released and the camshaft timing gear revolves in the advance direction.

- (5) When the camshaft timing gear reaches the most advanced position, release the air pressure on the timing retard side path, and then release the air pressure on the timing advance side path.

NOTICE:

Camshaft timing gear assembly occasionally shifts to the retard side abruptly if the air pressure on the advance side path is released first. This often results in breakage of the lock pin.

- (c) Check the revolution.
- (1) Rotate the valve timing assembly back and forth several times, except where the lock pin meets it at the most retarded angle. Check the movable range and that it rotates smoothly.

Standard:

Smooth movable range is about 22.5°

NOTICE:

Perform this check by hand, instead of using air pressure.

- (d) Check that the gear locks in the most retarded position.
- (1) Confirm that the camshaft timing gear assembly is locked in the most retarded position.

INSTALLATION

1. INSTALL CAMSHAFT TIMING GEAR ASSEMBLY

NOTICE:

Install the camshaft timing gear assembly onto the camshaft with the lock pin of the camshaft timing gear assembly released.

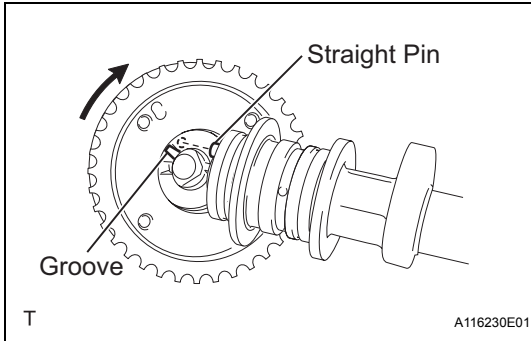

- Put the camshaft timing gear assembly and camshaft together with the straight pin of the groove.
- Turn the camshaft timing gear assembly clockwise while pushing it gently toward the camshaft. When the pin fits the groove, push to ensure a good fit.

NOTICE:

Do not turn the camshaft timing gear in the retard direction (clockwise).

- Check that there is no clearance between the gear flange and the camshaft.
- Tighten the flange bolt with the camshaft timing gear fixed.

Torque: 64 N*m (653 kgf*cm, 47 ft.*lbf)

NOTICE:

- Do not lock the camshaft timing gear assembly when tightening the bolt.
 - Release the lock pin of the camshaft timing gear assembly first, and tighten the bolt when the lock pin is locked in the most retarded position.
 - Tightening the bolts with the lock pin locked could cause breakage of the lock pin.
- Check that the camshaft timing gear assembly moves smoothly in the retard direction (clockwise) and is locked in the most retarded position.

2. INSTALL CAMSHAFT

- Apply a light coat of engine oil to the camshaft and camshaft journals.
- Install the chain onto the camshaft timing gear with the paint mark and the timing mark aligned as shown in the illustration.

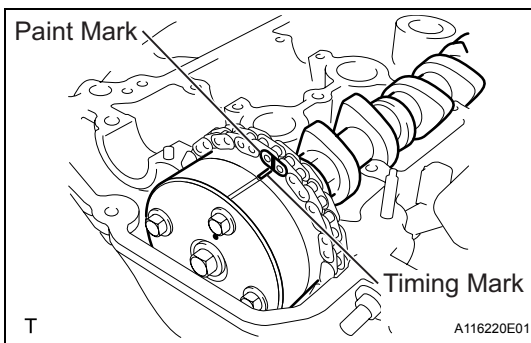

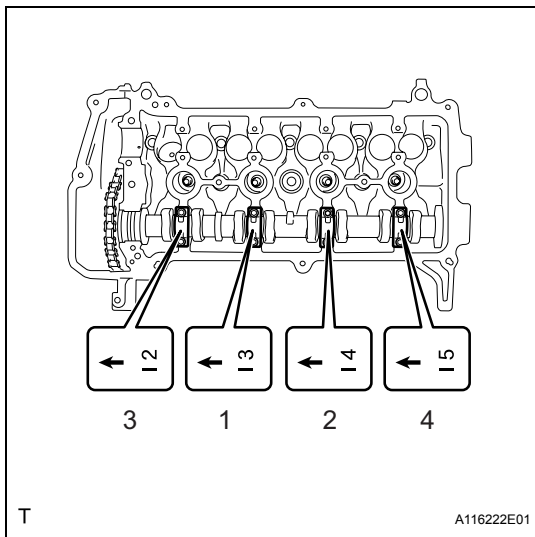

- (c) Examine the front marks and numbers on camshaft bearing cap No. 2 and check that the sequence is as shown in the illustration. Then uniformly tighten the bolts, in several steps, in the sequence shown in the illustration.

Torque: 13 N*m (129 kgf*cm, 9.4 ft.*lbf)

NOTICE:

Tighten each bolt uniformly while keeping the camshaft level.

EM

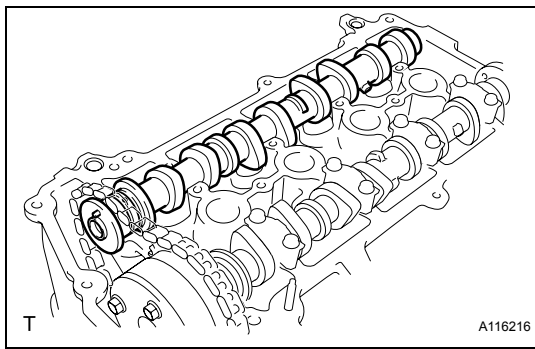

3. INSTALL NO. 2 CAMSHAFT

- (a) Install camshaft No. 2.

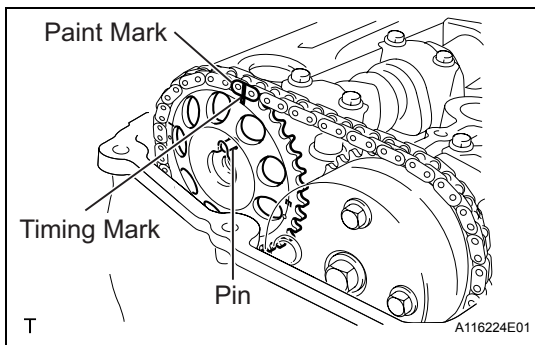

- (b) Hold the chain and align the timing mark on the camshaft timing sprocket with the paint mark of the chain.
- (c) Align the alignment pin hole in the camshaft timing sprocket with the alignment pin of the camshaft, and install the sprocket onto the camshaft.

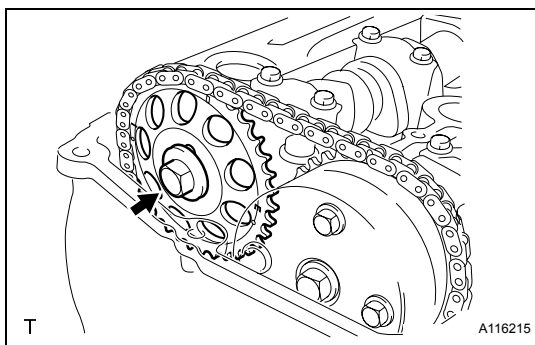

- (d) Provisionally install the flange bolt.

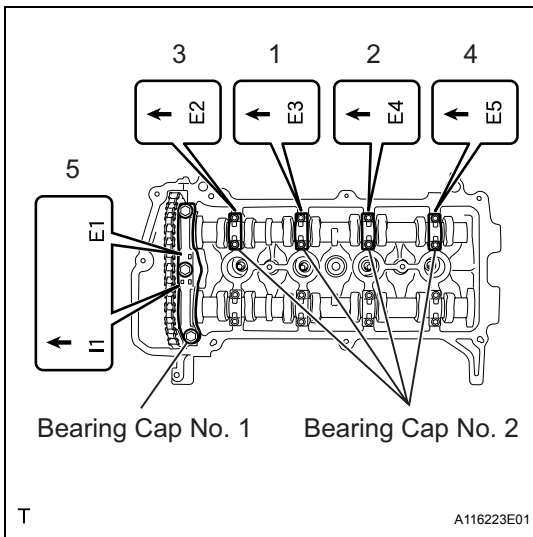

- (e) Examine the front marks and numbers on camshaft bearing caps No. 1 and No. 2 and check that the sequence is as shown in the illustration. Then uniformly tighten the bolts, in several steps, in the sequence shown in the illustration.

Torque: for bearing cap No. 2

13 N*m (129 kgf*cm, 9.4 ft.*lbf)

for bearing cap No. 1

23 N*m (235 kgf*cm, 17 ft.*lbf)

NOTICE:

Tighten each bolt uniformly while keeping the camshaft level.

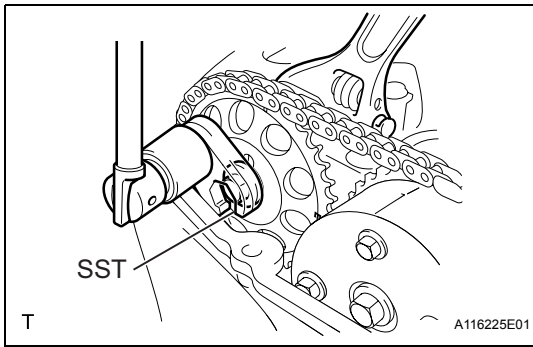

- (f) Using a wrench, hold the hexagonal lobe of camshaft No. 2 and install the flange bolt.

SST 09023-38400

Torque: 64 N*m (653 kgf*cm, 47 ft.*lbf)

- (g) Remove the bar from the timing chain tensioner.

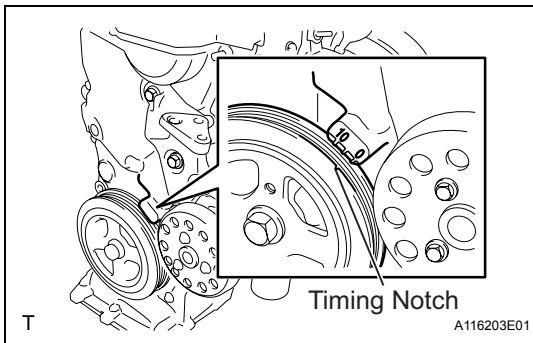

- (h) Turn the crankshaft damper and align its timing notch with the timing mark "0" of the oil pump.

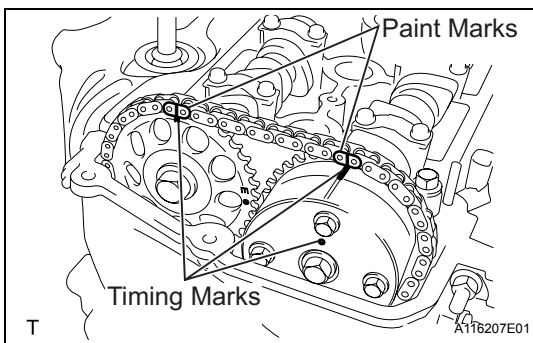

- (i) Check that all the pairs of timing marks are aligned.
 (j) Apply adhesive to the end 2 or 3 threads of the screw plug.

Adhesive:

Toyota Genuine Adhesive 1324, Three Bond 1324 or Equivalent

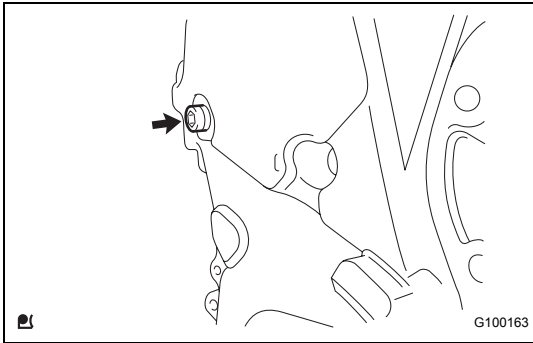

(k) Using an 8 mm hexagon wrench, install the screw plug.

Torque: 15 N*m (153 kgf*cm, 11 ft.*lbf)

4. **INSPECT VALVE CLEARANCE** (See page [EM-9](#))
5. **ADJUST VALVE CLEARANCE** (See page [EM-10](#))
6. **INSTALL ENGINE MOUNTING INSULATOR SUB-ASSEMBLY RH** (See page [LU-26](#))
7. **INSTALL FAN AND GENERATOR V BELT** (See page [EM-7](#))
8. **ADJUST FAN AND GENERATOR V BELT** (See page [EM-7](#))
9. **INSPECT FAN AND GENERATOR V BELT** (See page [EM-8](#))
10. **INSTALL CYLINDER HEAD COVER SUB-ASSEMBLY** (See page [FU-19](#))
11. **CONNECT VENTILATION HOSE NO. 2** (See page [FU-20](#))
12. **CONNECT VENTILATION HOSE** (See page [FU-20](#))
13. **INSTALL IGNITION COIL NO. 1** (See page [IG-9](#))
14. **CONNECT CABLE TO NEGATIVE BATTERY TERMINAL**
Torque: 5.4 N*m (55 kgf*cm, 48 in.*lbf)
15. **CHECK FOR ENGINE OIL LEAKAGE**
16. **INSTALL CYLINDER HEAD COVER NO. 2** (See page [IG-10](#))
17. **INSTALL ENGINE UNDER COVER RH**

CYLINDER HEAD

COMPONENTS

for Hatchback:

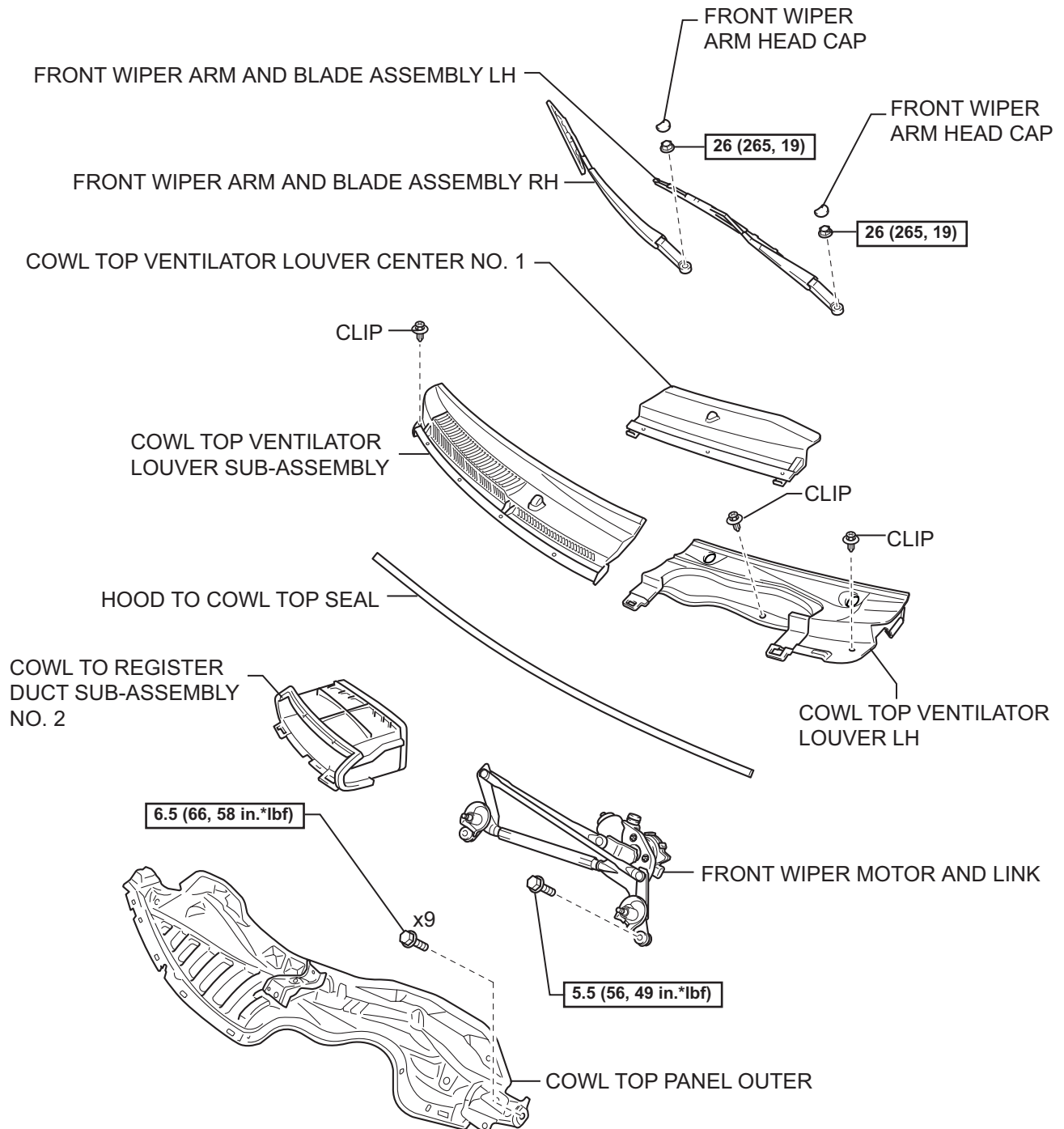

EM

N*m (kgf*cm, ft*lbf) : Specified torque

for Sedan:

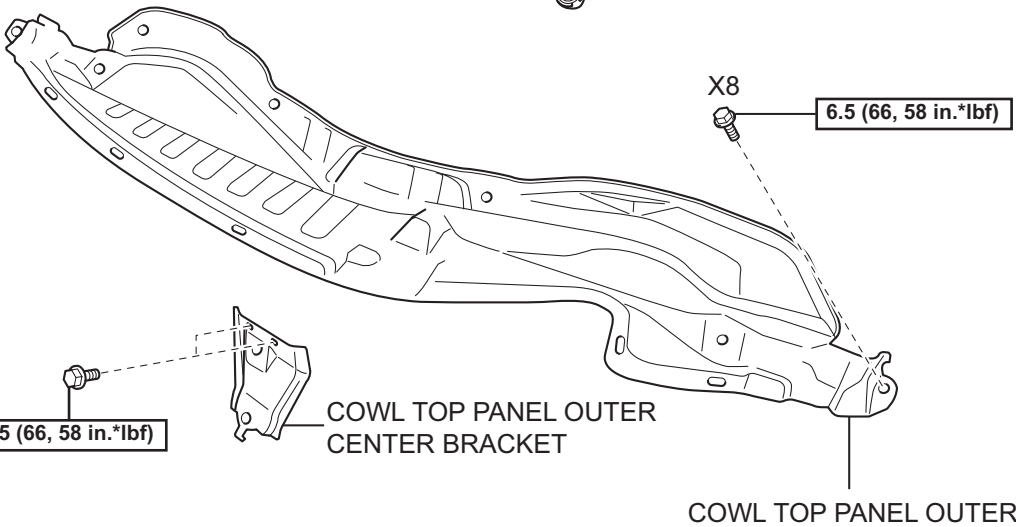
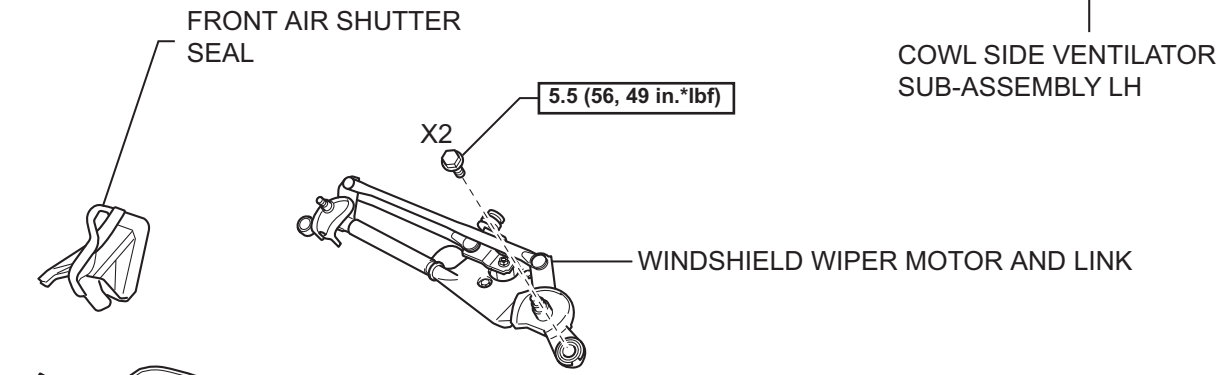
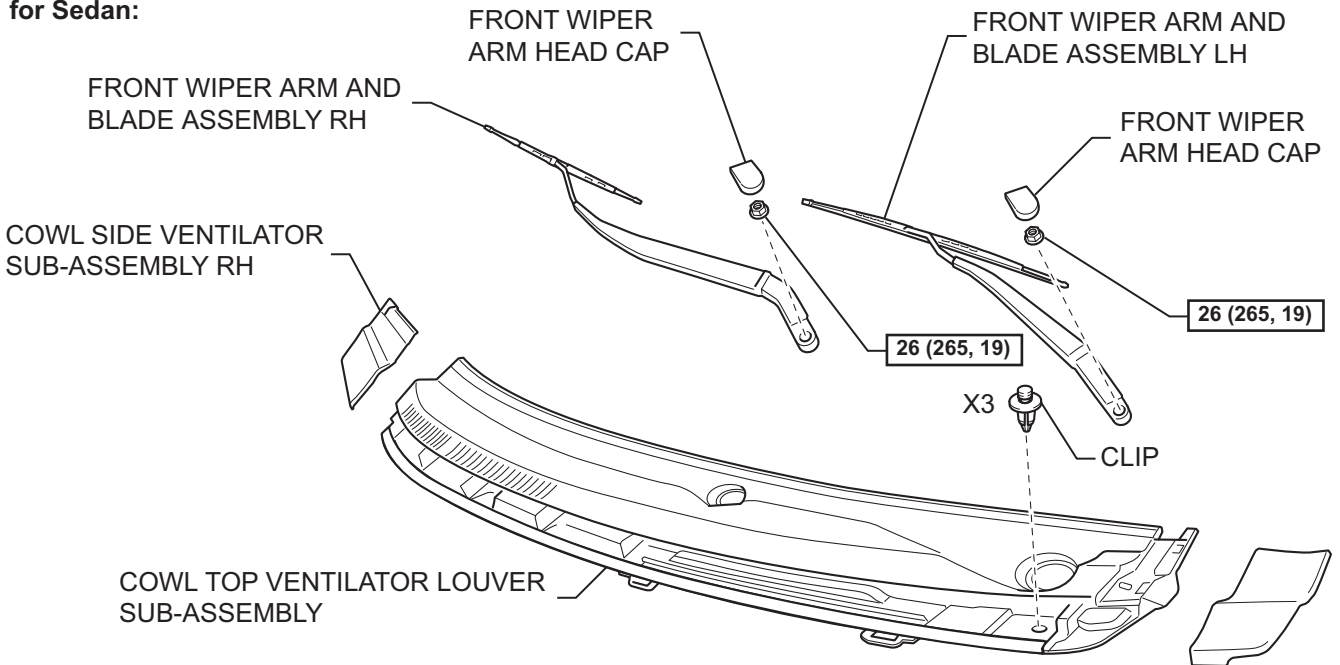

N*m (kgf*cm, ft.*lbf) : Specified torque

EM

Y

EM

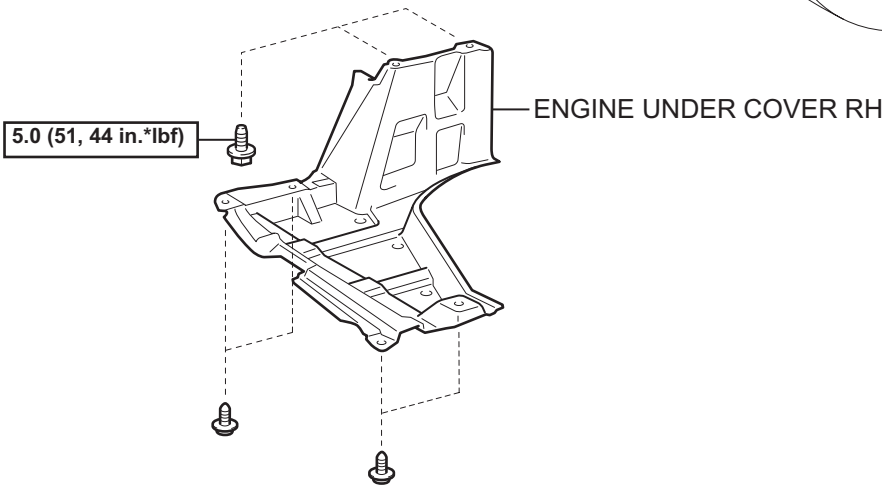
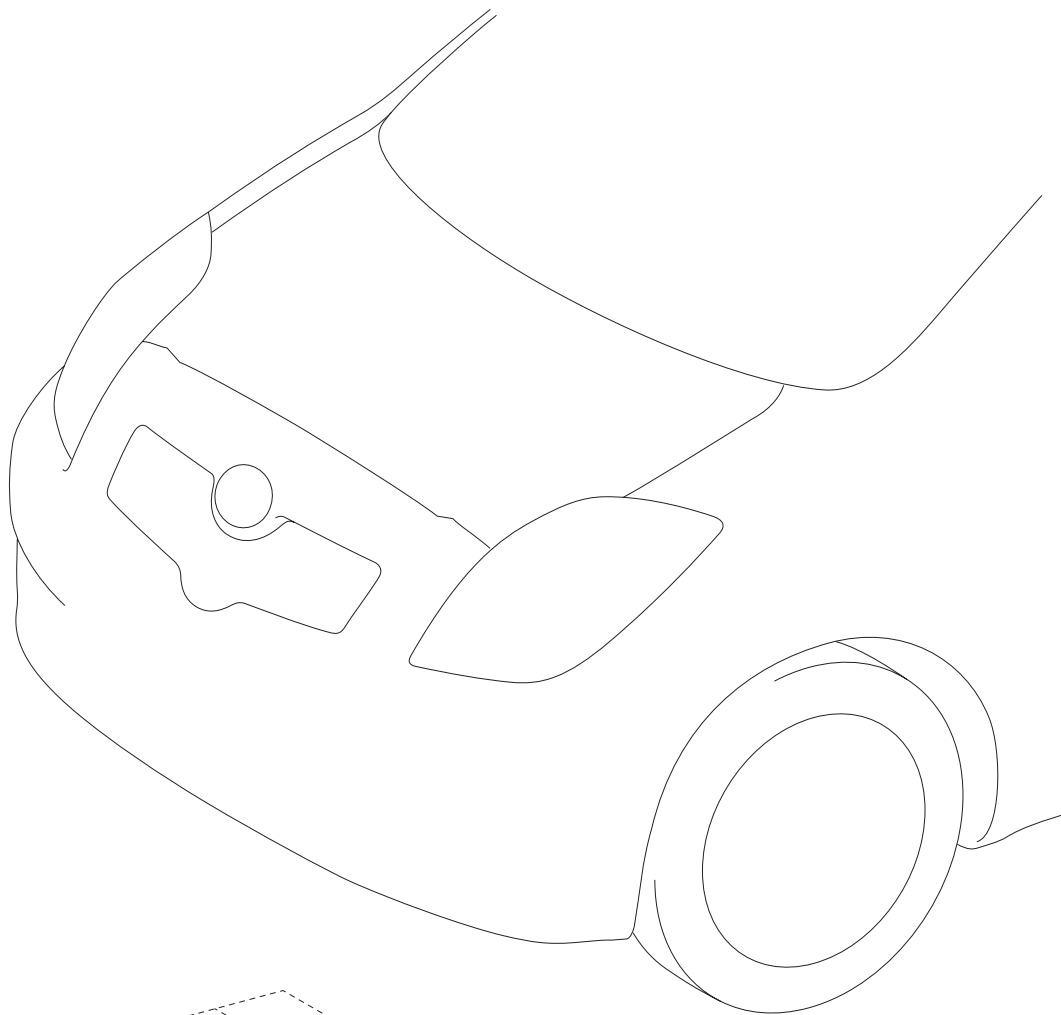

N*m (kgf*cm, ft.*lbf) : Specified torque

T

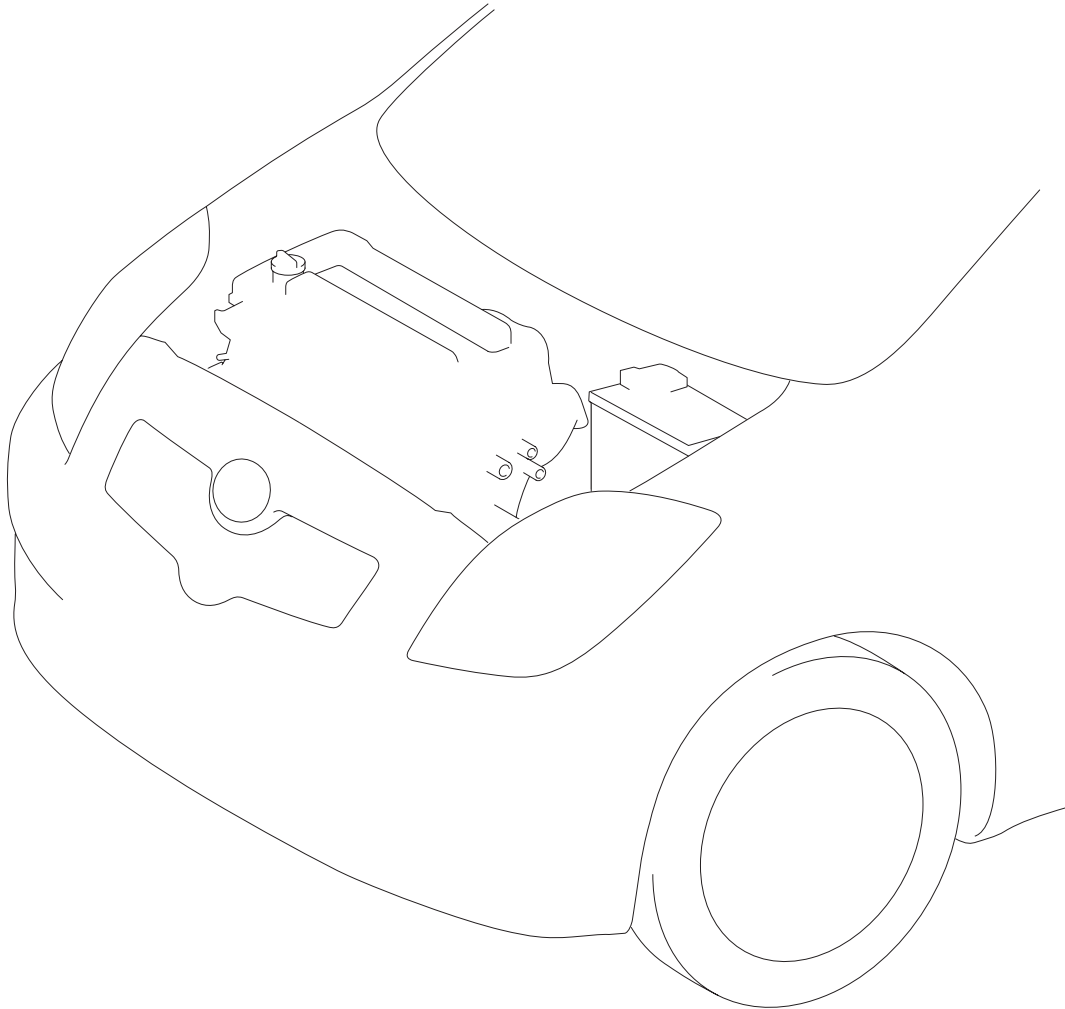
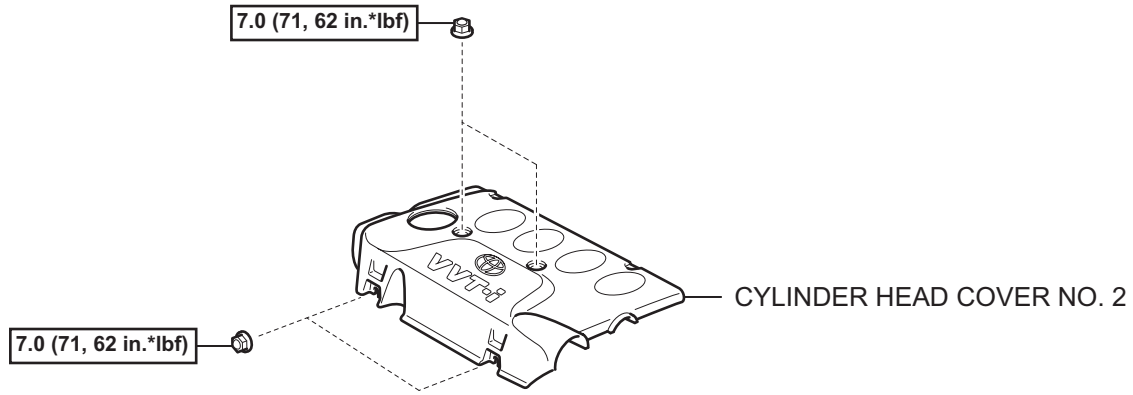

N*m (kgf*cm, ft.*lbf) : Specified torque

T

EM

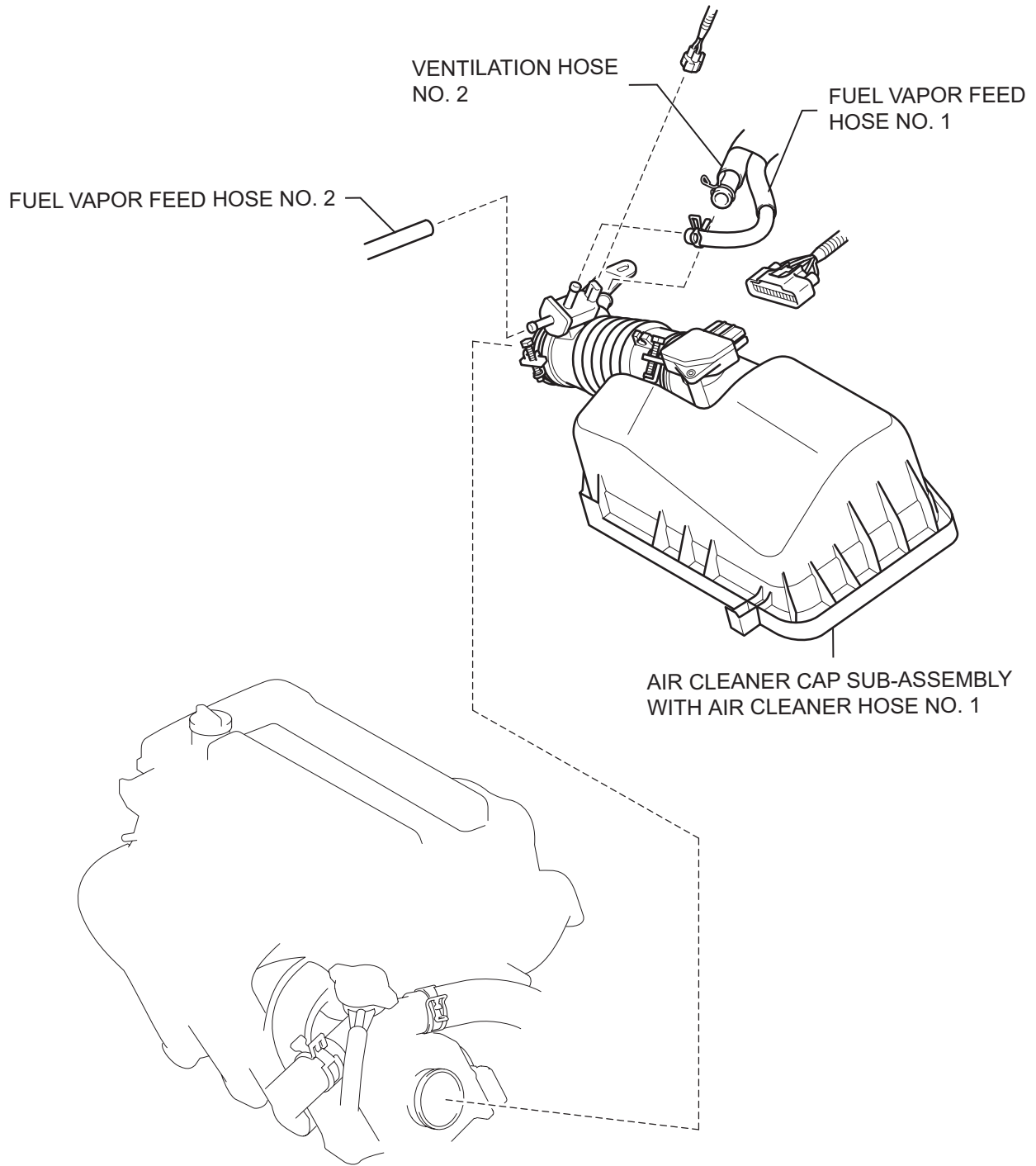

EM

EM

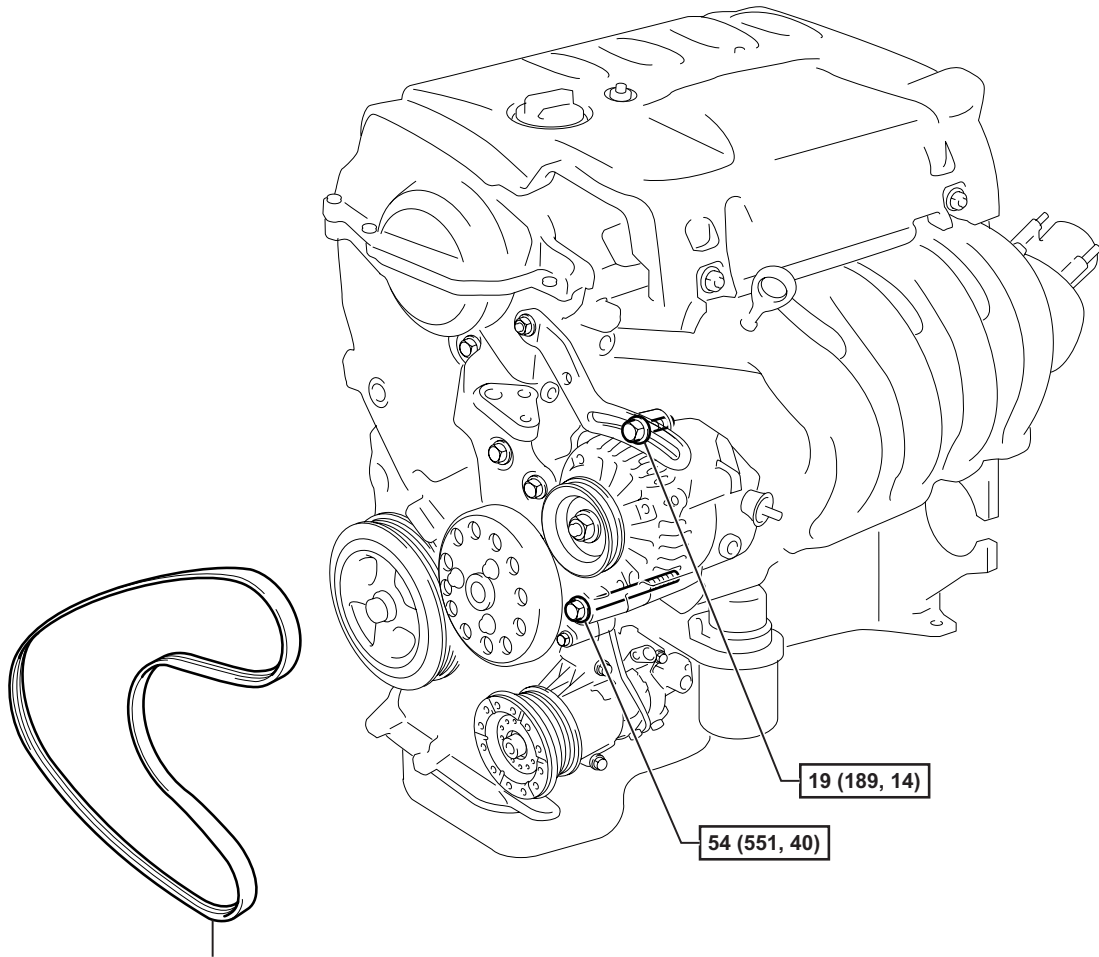

FAN AND GENERATOR V BELT

N*m (kgf*cm, ft.*lbf) : Specified torque

T

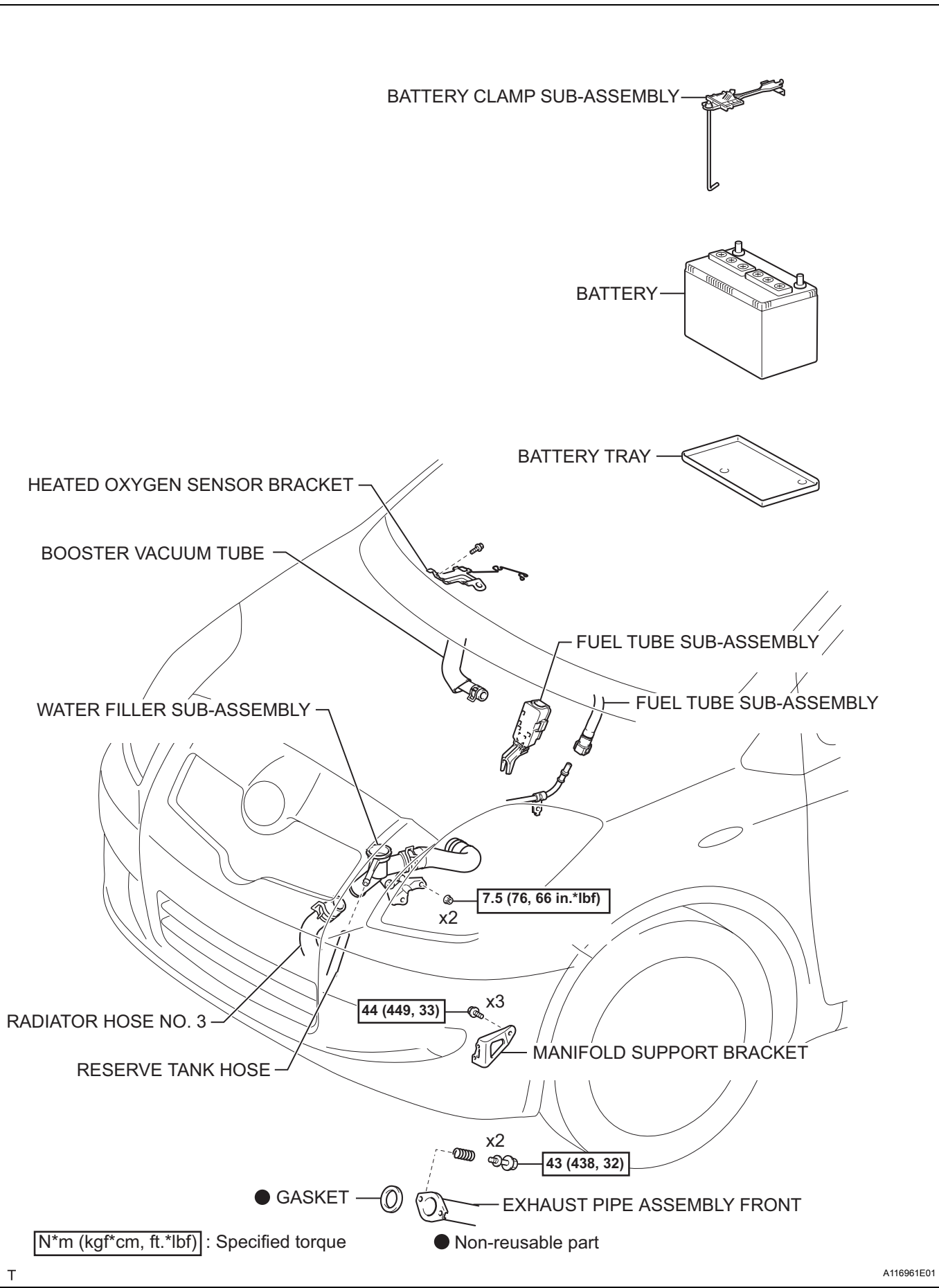

for Hatchback:

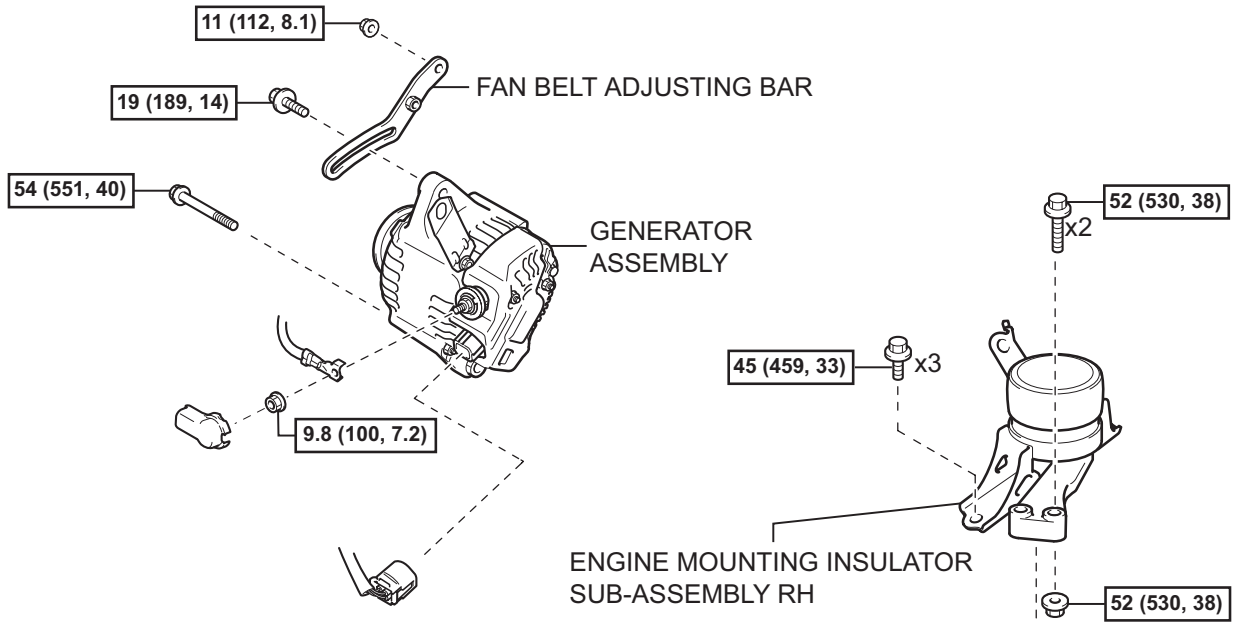

EM

N*m (kgf*cm, ft.*lbf) : Specified torque

T

for Sedan:

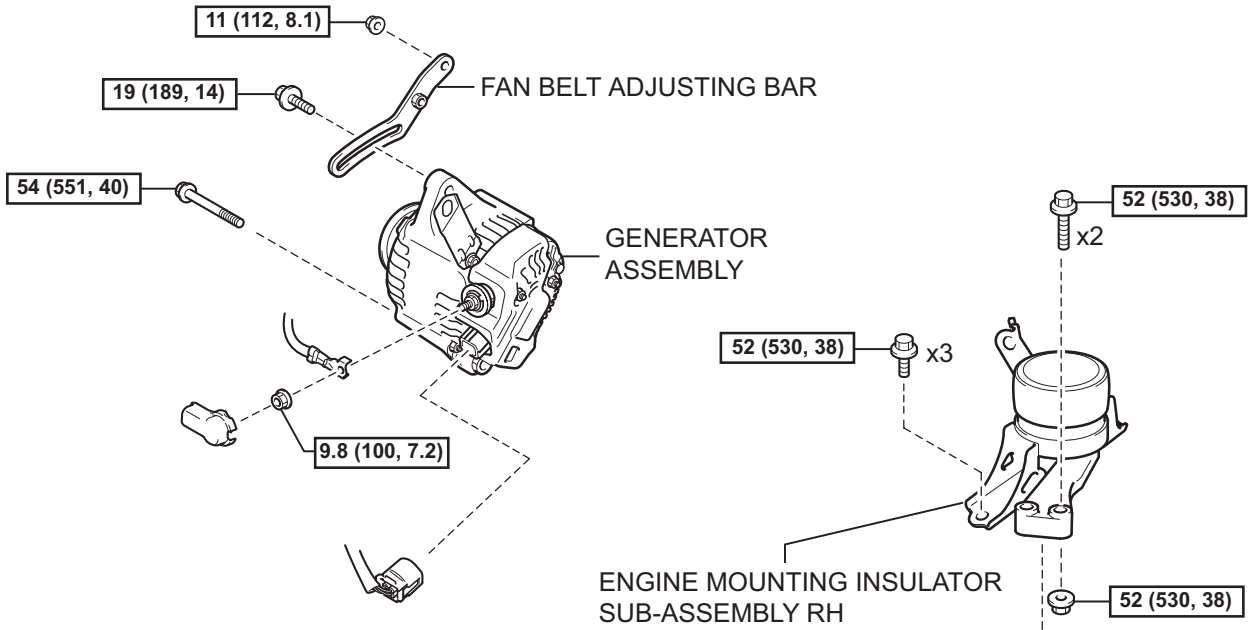

EM

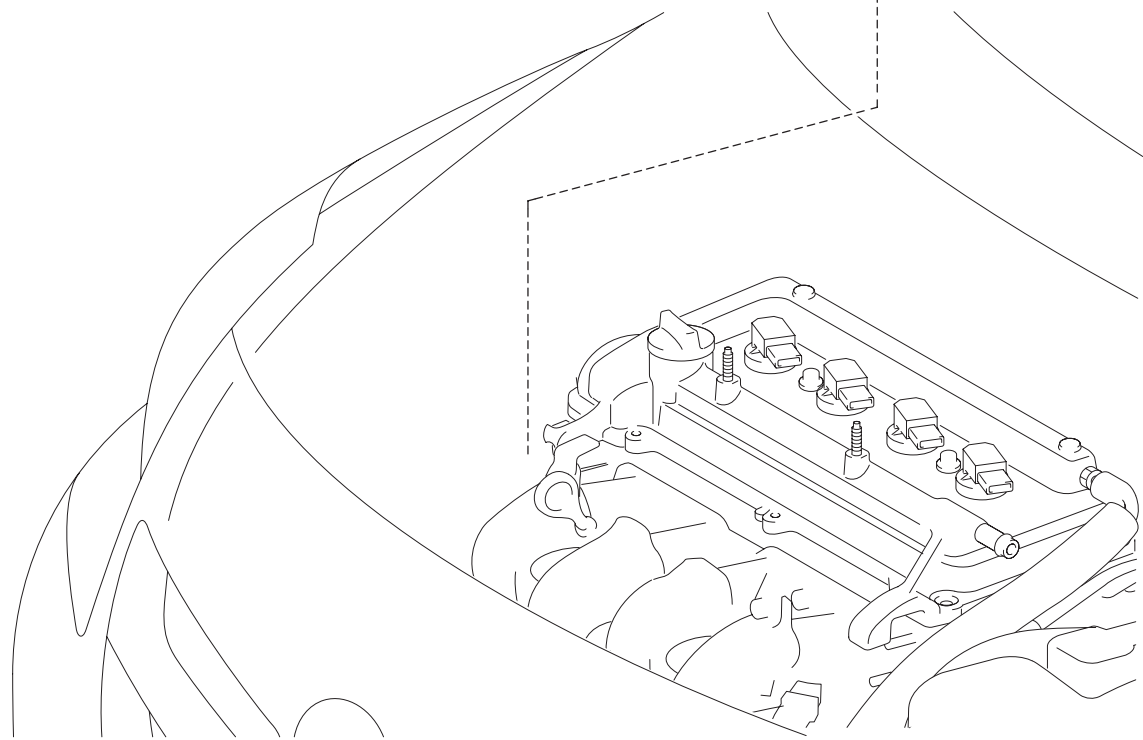

N*m (kgf*cm, ft*lbf) : Specified torque

EM

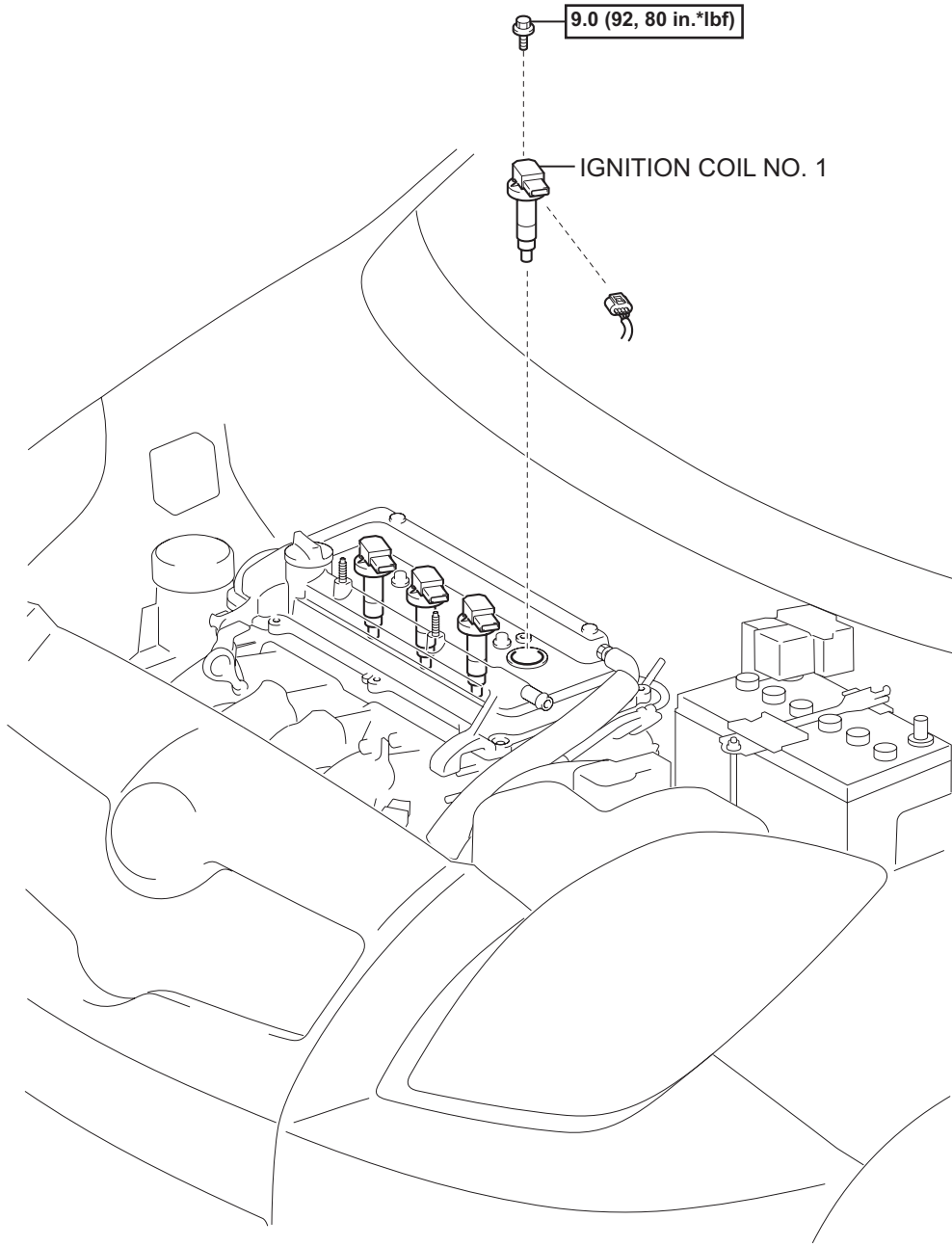

$\boxed{\text{N}^*\text{m (kgf}^*\text{cm, ft.}^*\text{lbf)}}$: Specified torque

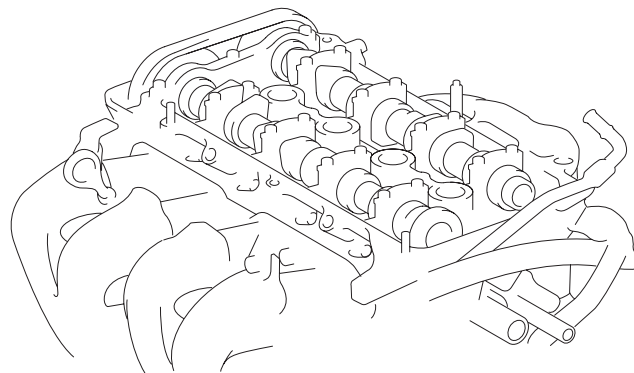
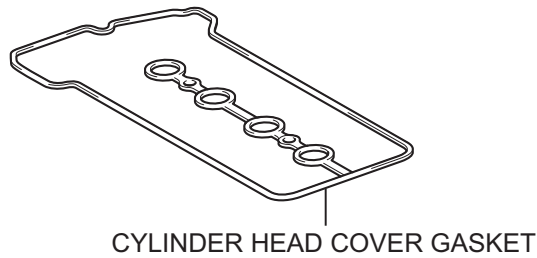
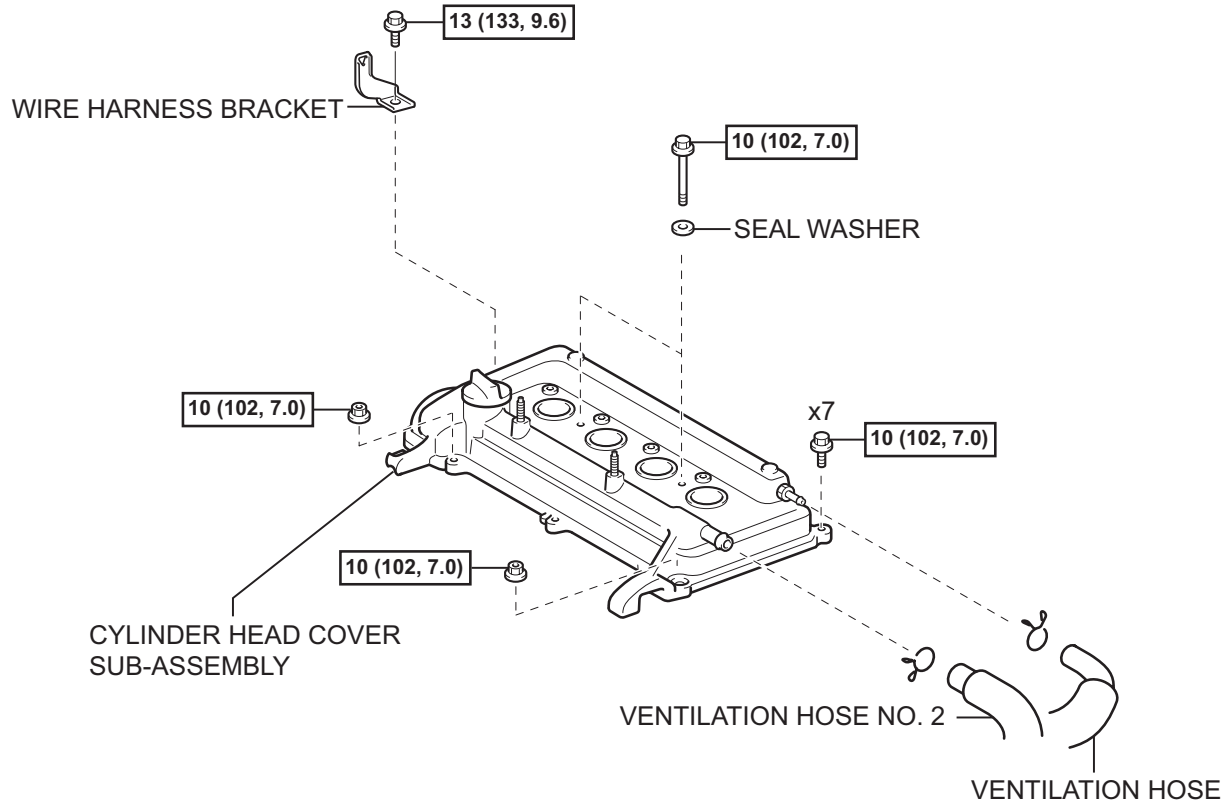

N*m (kgf*cm, ft.*lbf) : Specified torque

EM

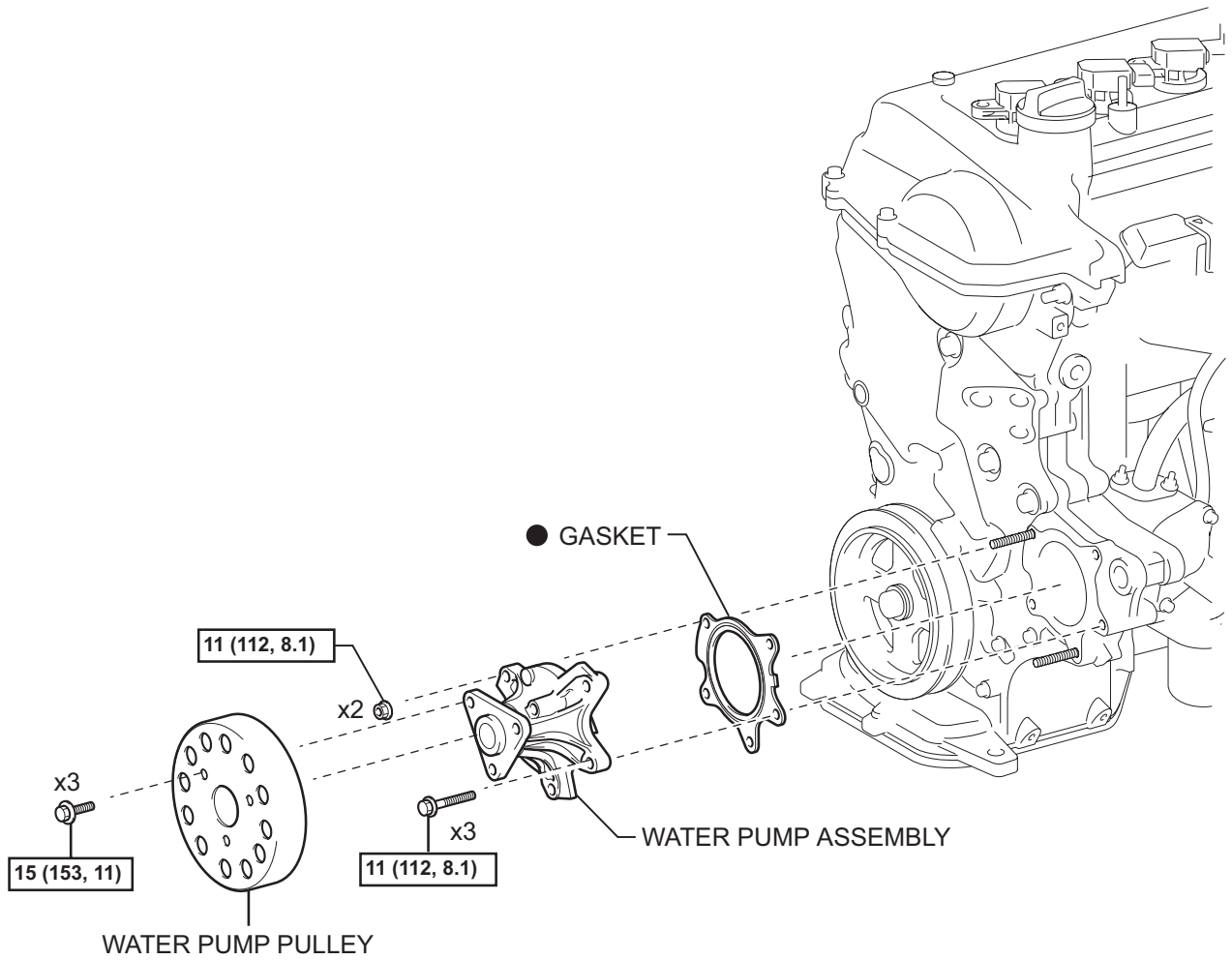

N*m (kgf*cm, ft.*lbf) : Specified torque

● Non-reusable part

T

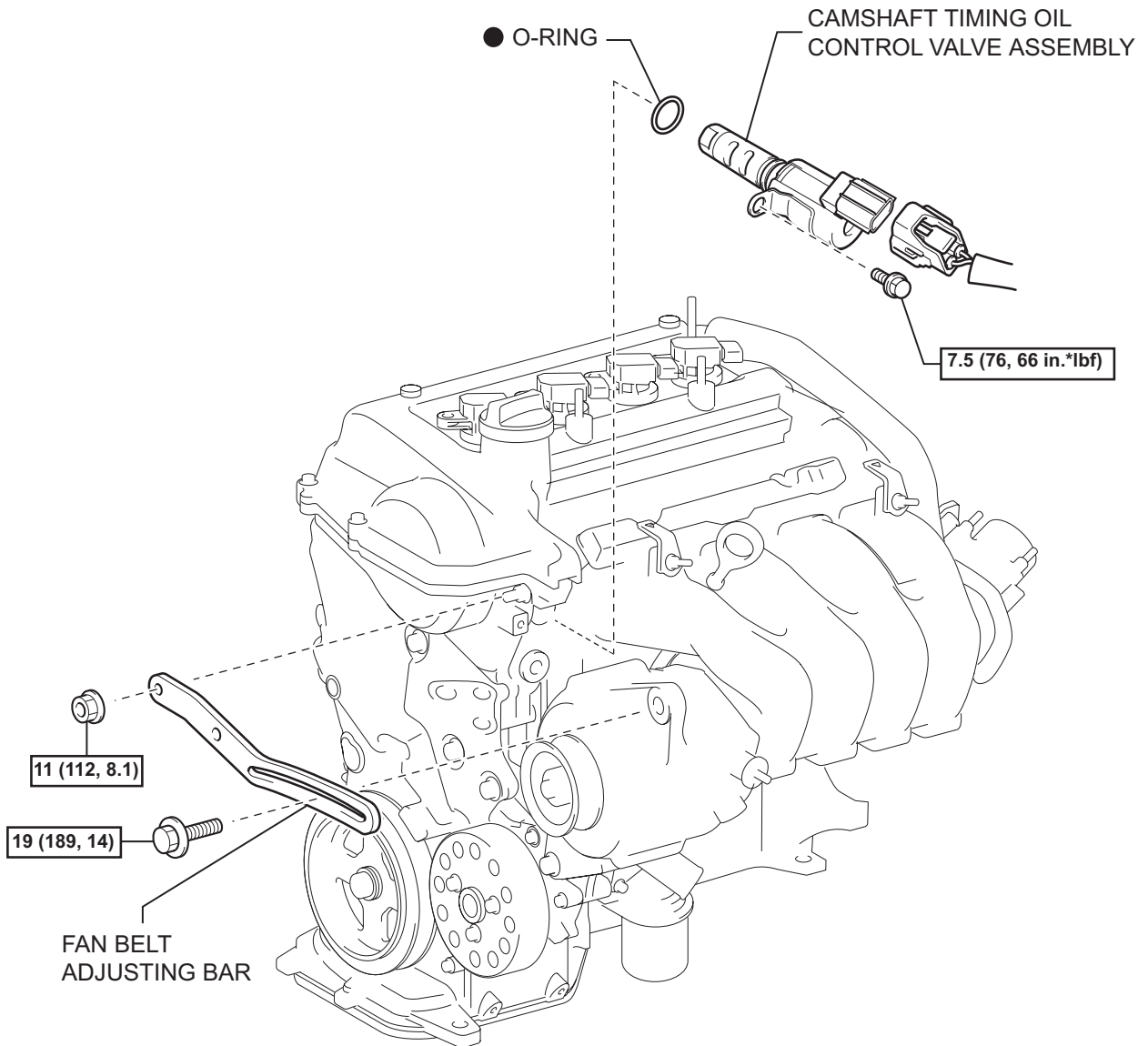

[N*m (kgf*cm, ft.*lbf)] : Specified torque

● Non-reusable part

EM

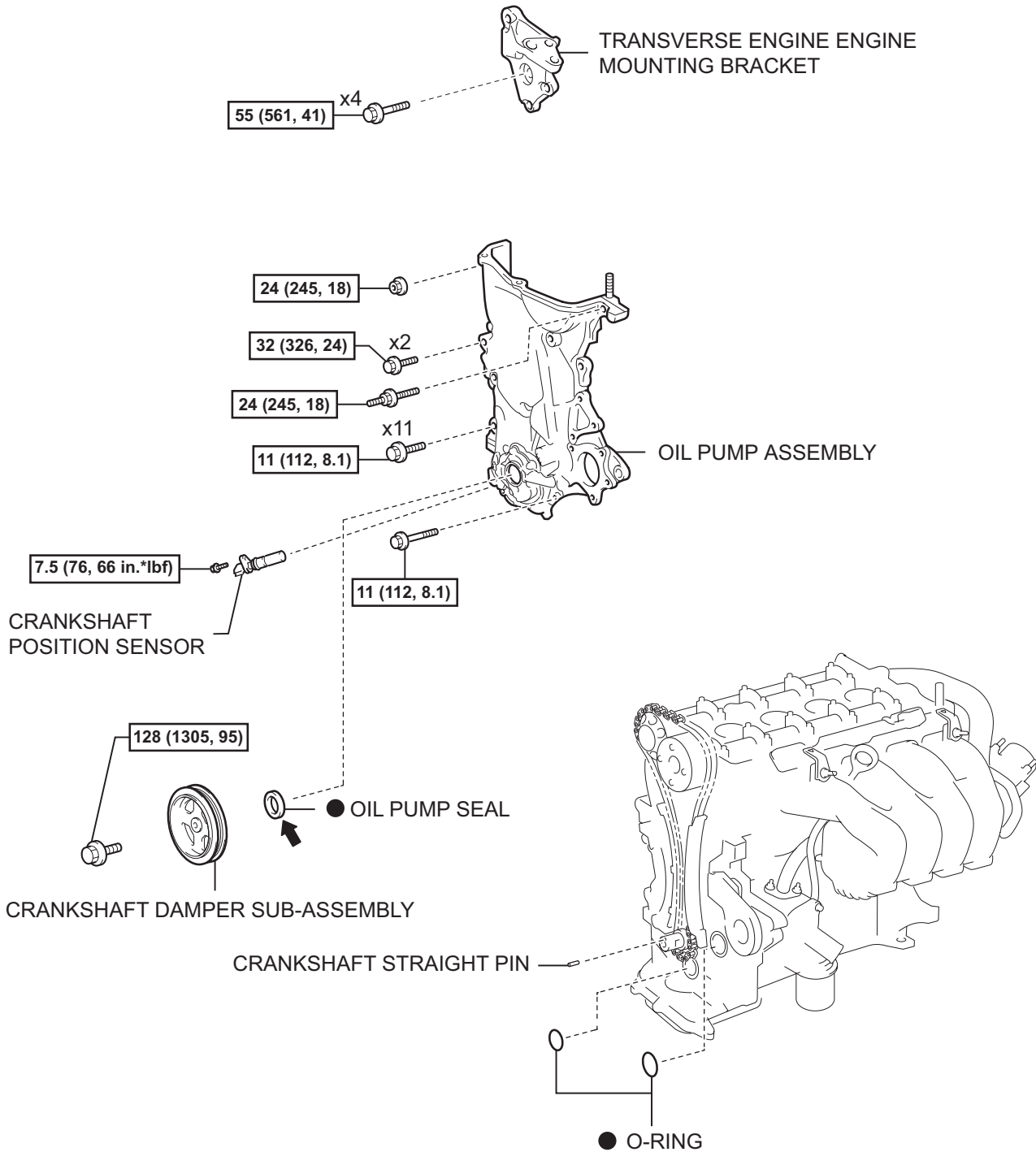

[N*m (kgf*cm, ft.*lbf)] : Specified torque

● Non-reusable part ← Apply MP grease

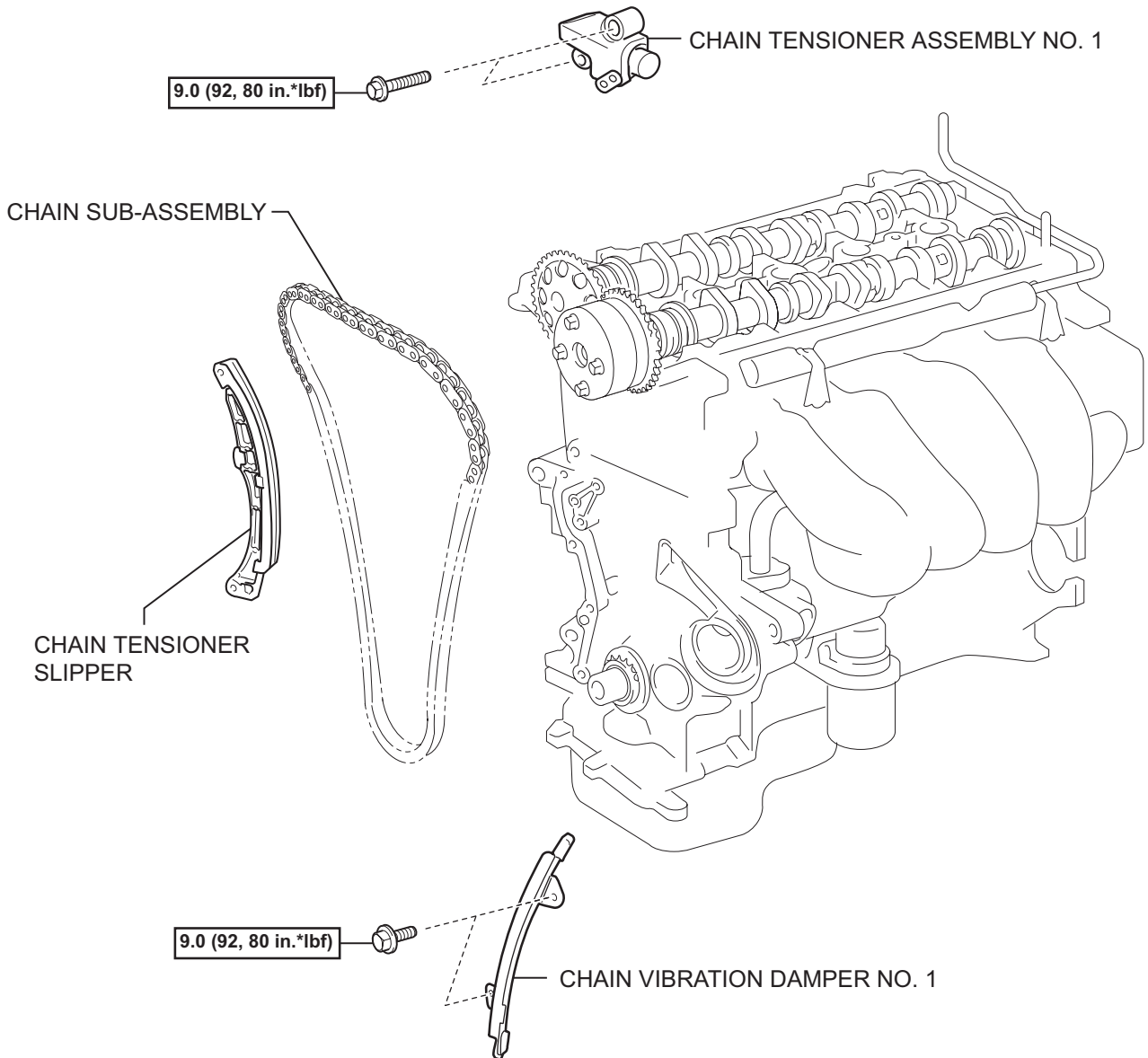

N*m (kgf*cm, ft.*lbf) : Specified torque

EM

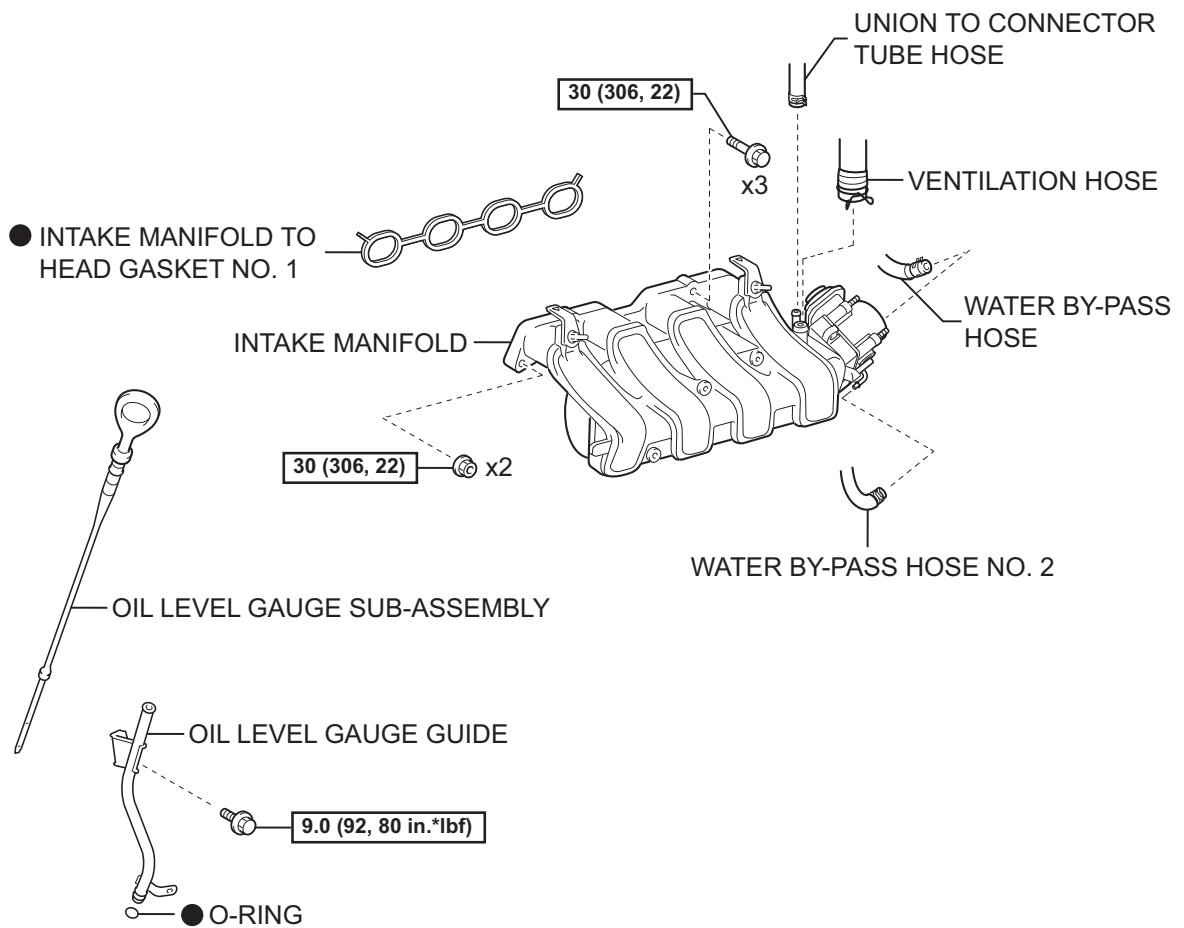
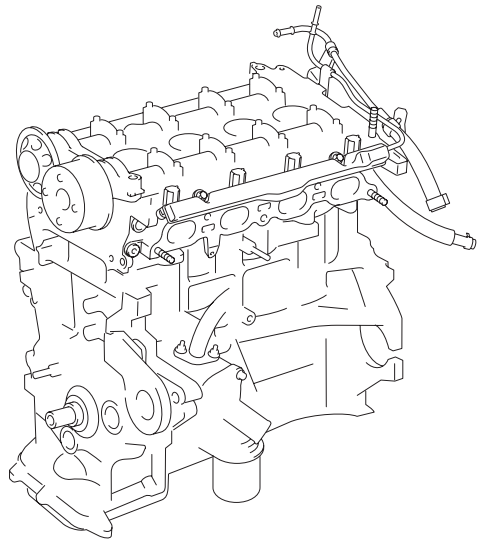

N*m (kgf*cm, ft*lbf) : Specified torque

● Non-reusable part

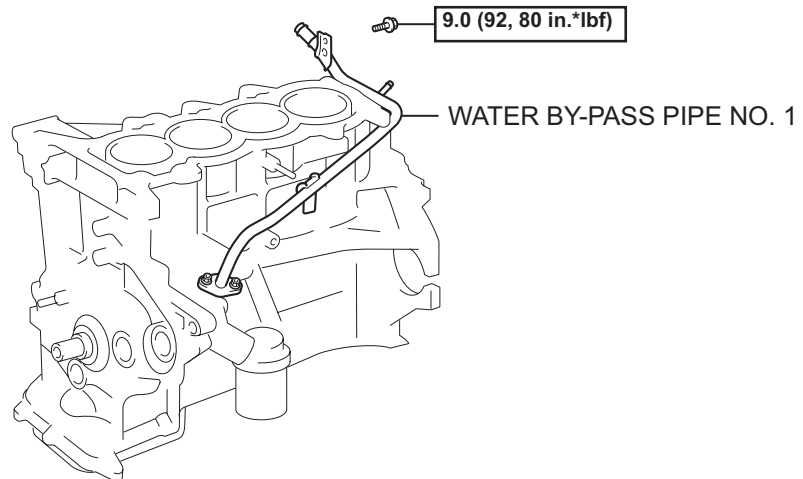
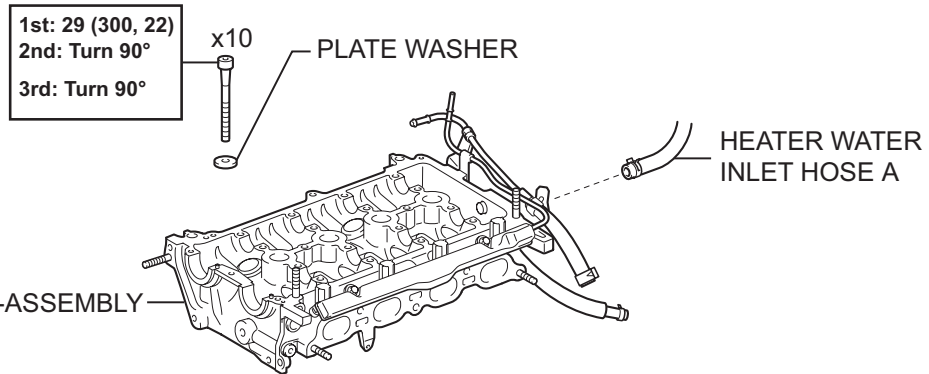
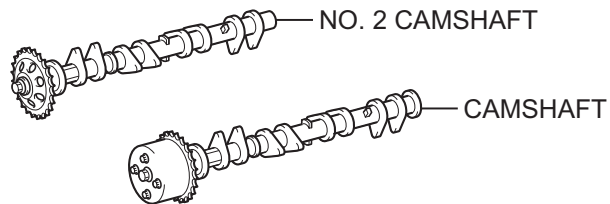
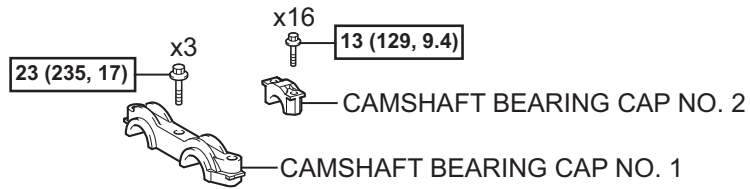

[N*m (kgf*cm, ft.*lbf)] : Specified torque

● Non-reusable part

EM

EM

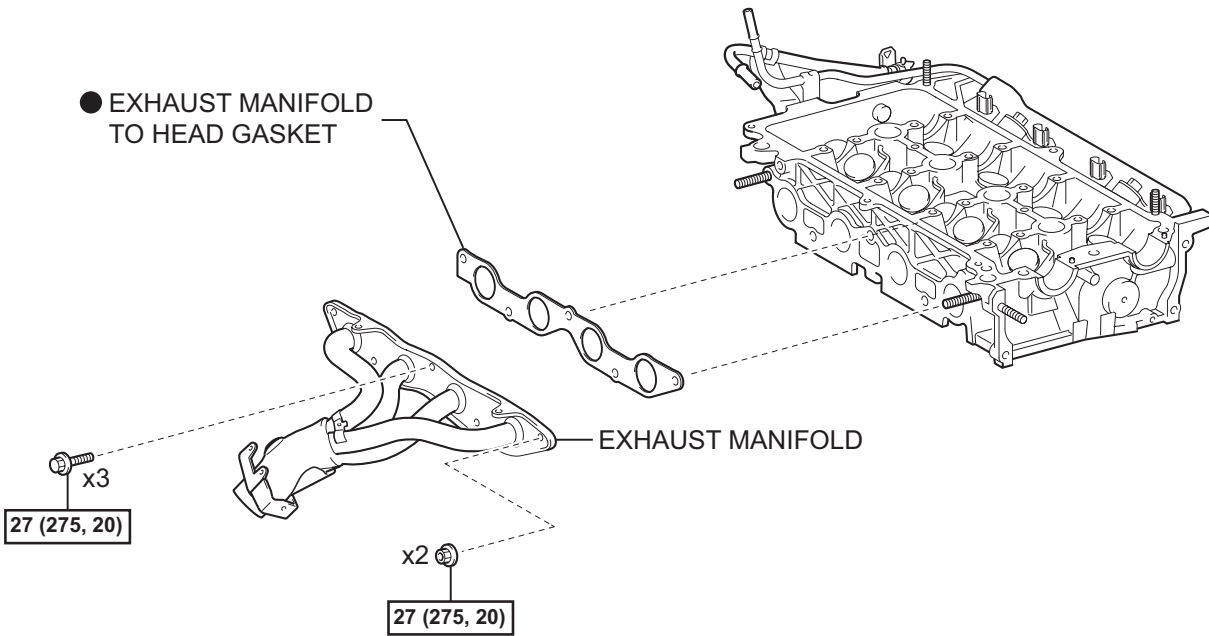
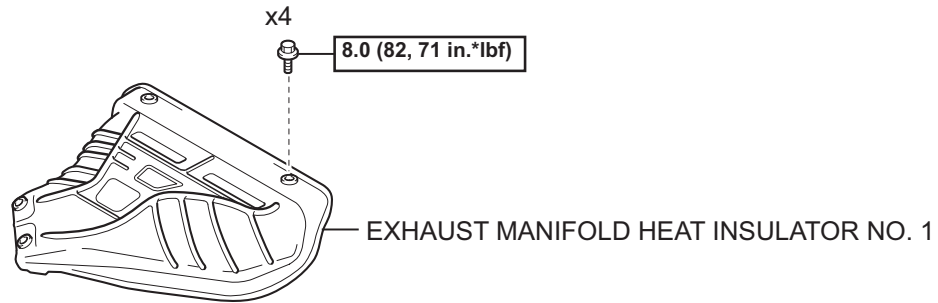

N*m (kgf*cm, ft.*lbf) : Specified torque

● Non-reusable part

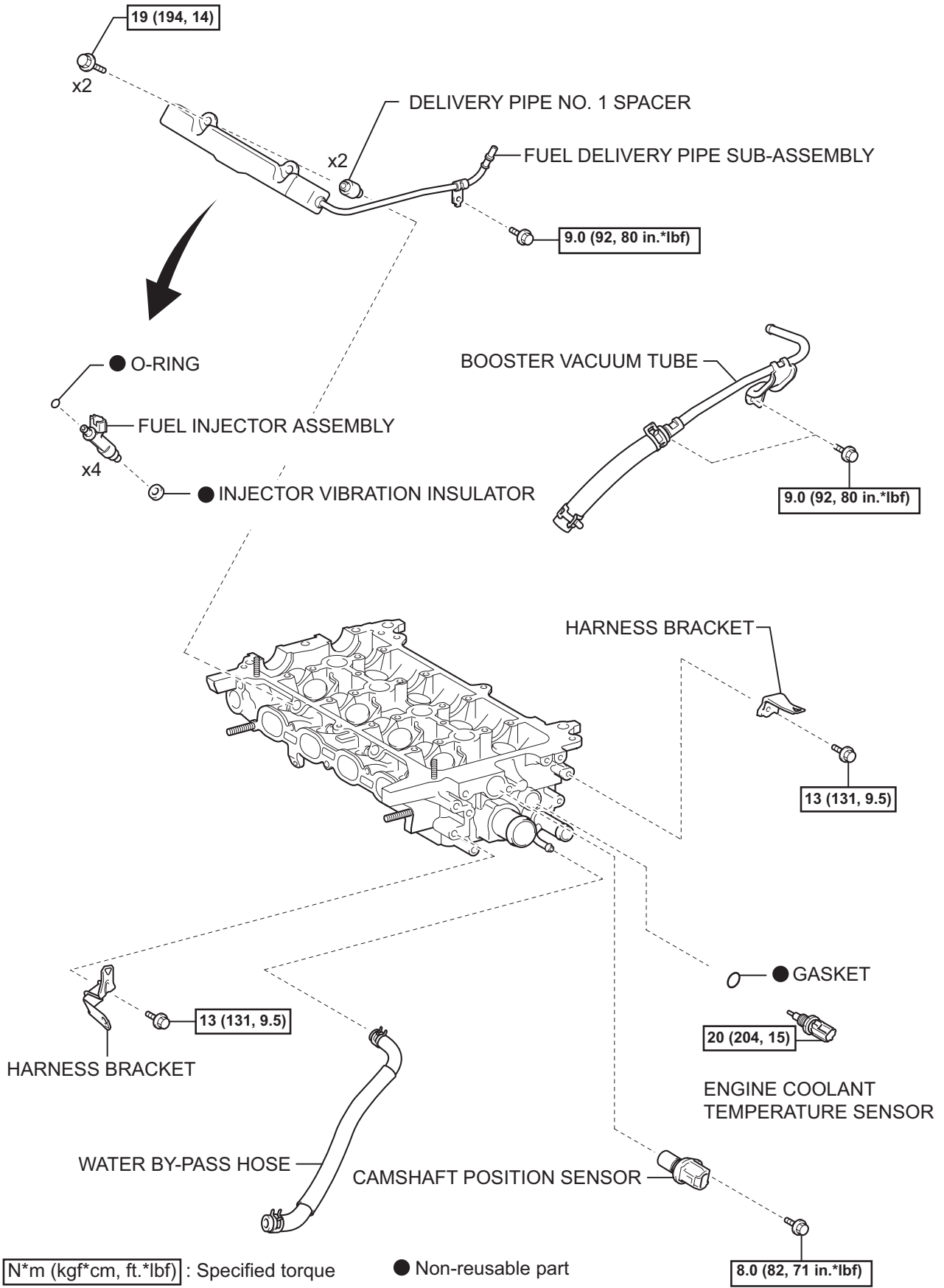

EM

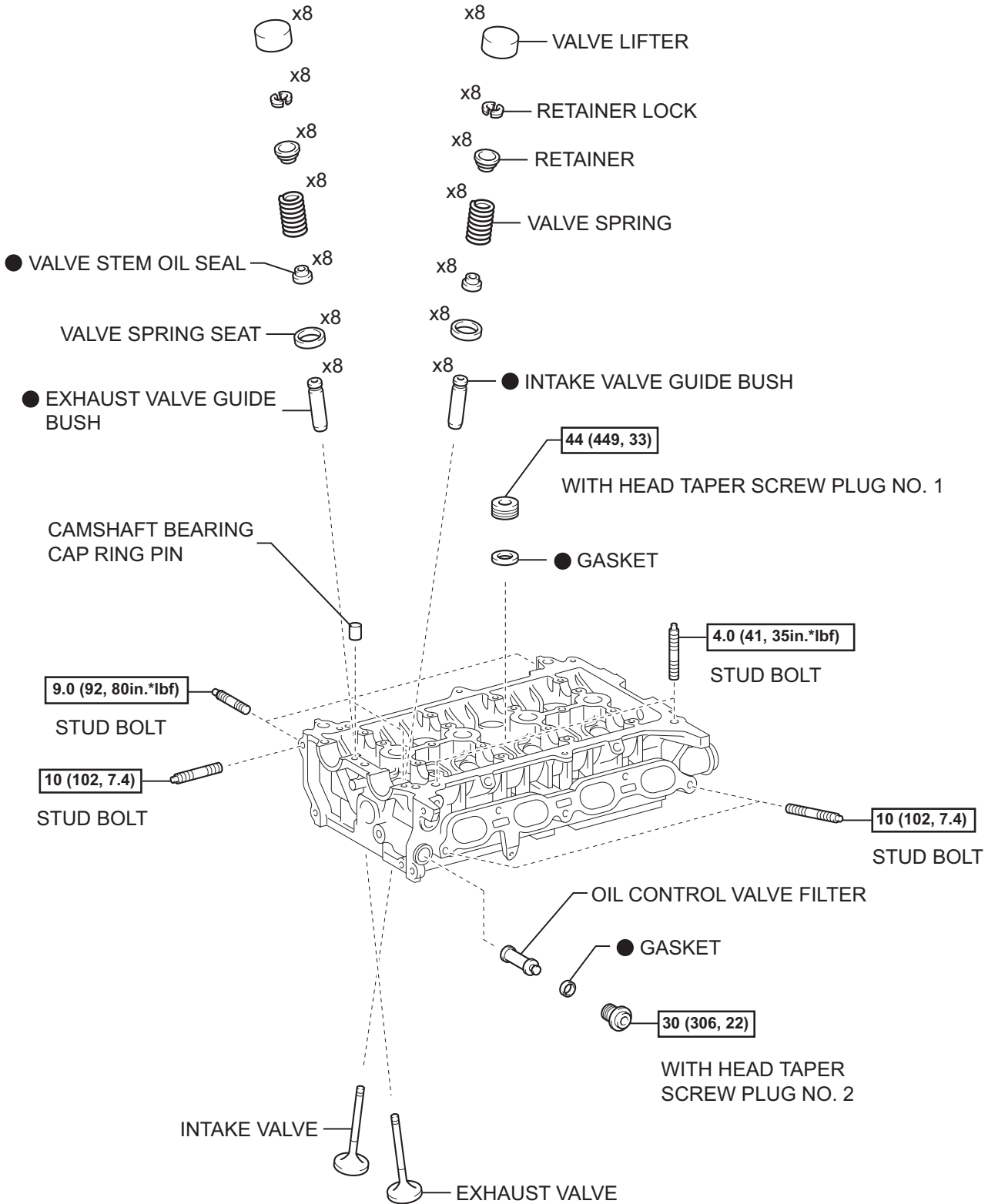

N*m (kgf*cm, ft.*lbf) : Specified torque

● Non-reusable part

T

REMOVAL

1. DISCHARGE FUEL SYSTEM PRESSURE
(See Page [FU-1](#))
2. DISCONNECT CABLE FROM NEGATIVE BATTERY TERMINAL
3. REMOVE FRONT WIPER ARM HEAD CAP (for Hatchback) (See page [WW-17](#))
4. REMOVE FRONT WIPER ARM HEAD CAP (for Sedan) (See page [WW-9](#))
5. REMOVE FRONT WIPER ARM AND BLADE ASSEMBLY LH (for Hatchback) (See page [WW-17](#))
6. REMOVE FRONT WIPER ARM AND BLADE ASSEMBLY LH (for Sedan) (See page [WW-9](#))
7. REMOVE FRONT WIPER ARM AND BLADE ASSEMBLY RH (for Hatchback) (See page [WW-17](#))
8. REMOVE FRONT WIPER ARM AND BLADE ASSEMBLY RH (for Sedan) (See page [WW-9](#))
9. REMOVE HOOD TO COWL TOP SEAL (for Hatchback) (See page [WW-18](#))
10. REMOVE COWL TOP VENTILATOR LOUVER SUB-ASSEMBLY (for Hatchback) (See page [WW-18](#))
11. REMOVE COWL TOP VENTILATOR LOUVER LH (for Hatchback) (See page [WW-18](#))
12. REMOVE COWL SIDE VENTILATOR SUB-ASSEMBLY LH (for Sedan) (See page [WW-10](#))
13. REMOVE COWL SIDE VENTILATOR SUB-ASSEMBLY RH (for Sedan) (See page [WW-10](#))
14. REMOVE COWL TOP VENTILATOR LOUVER SUB-ASSEMBLY (for Sedan) (See page [WW-10](#))
15. REMOVE FRONT WIPER MOTOR AND LINK (for Hatchback) (See page [WW-19](#))
16. REMOVE FRONT WIPER MOTOR AND LINK (for Sedan) (See page [WW-10](#))
17. REMOVE COWL TO REGISTER DUCT SUB-ASSEMBLY NO. 2 (for Hatchback) (See page [EM-122](#))
18. REMOVE FRONT AIR SHUTTER SEAL RH (for Sedan) (See page [ES-432](#))
19. REMOVE COWL TOP PANEL OUTER (for Hatchback) (See page [EM-123](#))
20. REMOVE COWL TOP PANEL OUTER (for Sedan) (See page [ES-432](#))
21. REMOVE BATTERY
22. REMOVE BATTERY TRAY
23. REMOVE FRONT WHEEL RH

24. REMOVE ENGINE UNDER COVER RH
25. DRAIN ENGINE OIL
26. DRAIN ENGINE COOLANT (See page [CO-8](#))
27. REMOVE CYLINDER HEAD COVER NO. 2 (See page [IG-9](#))
28. REMOVE AIR CLEANER CAP SUB-ASSEMBLY WITH AIR CLEANER HOSE NO. 1 (See page [ES-410](#))
29. DISCONNECT RADIATOR HOSE NO. 3
 - (a) Disconnect radiator hose No. 3.

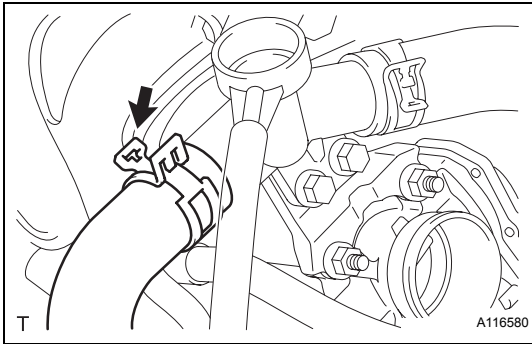

30. DISCONNECT RESERVE TANK HOSE
 - (a) Disconnect the reserve tank hose.

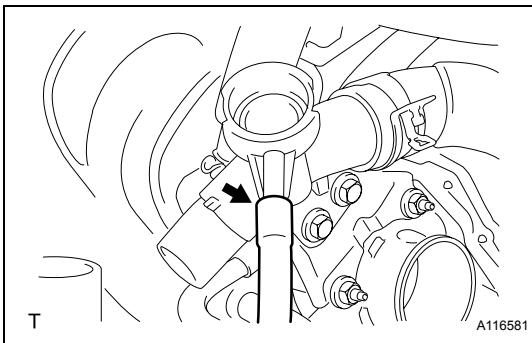

31. REMOVE WATER FILLER SUB-ASSEMBLY
 - (a) Separate radiator hose No. 1 from the cylinder head.
 - (b) Remove the 2 nuts and remove the water filler sub-assembly.

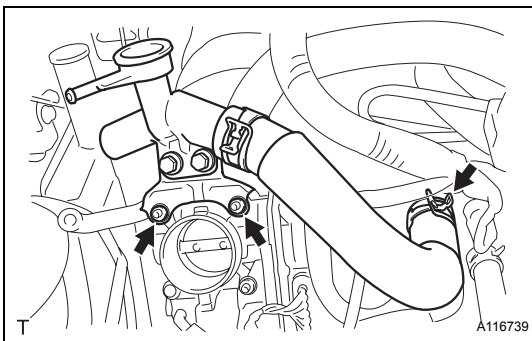

32. DISCONNECT WATER BY-PASS HOSE NO. 2
 - (a) Disconnect water by-pass hose No. 2.

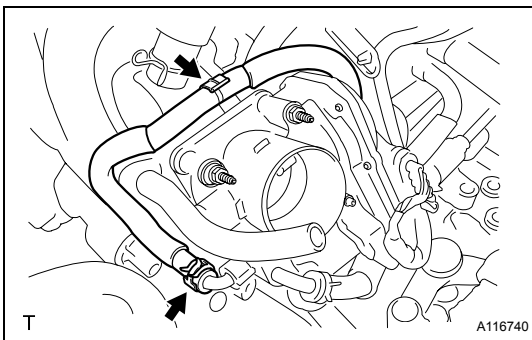

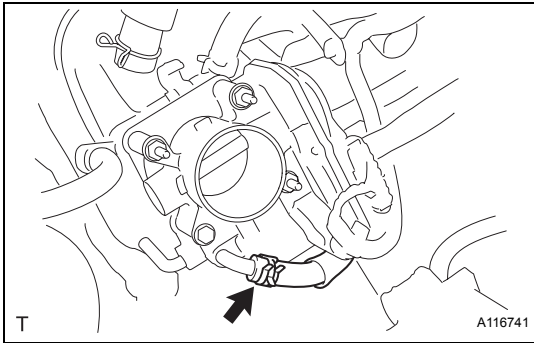
**33. DISCONNECT WATER BY-PASS HOSE**

- (a) Disconnect the water by-pass hose.

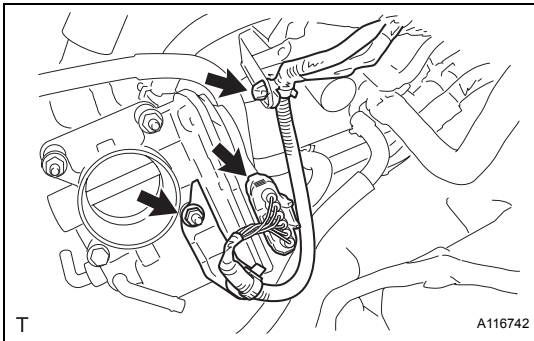
**34. DISCONNECT THROTTLE WITH MOTOR BODY CONNECTOR**

- (a) Separate the wire harness clamp.
 (b) Remove the nut and separate the throttle with motor body connector.

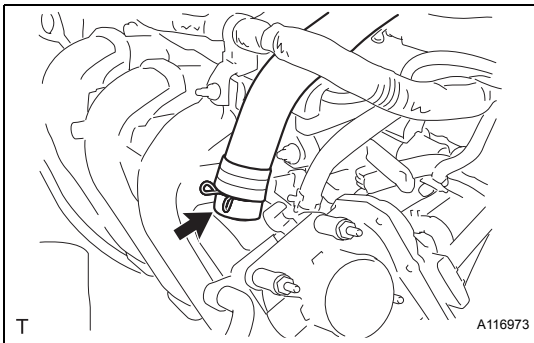
**35. DISCONNECT VENTILATION HOSE**

- (a) Disconnect the ventilation hose.

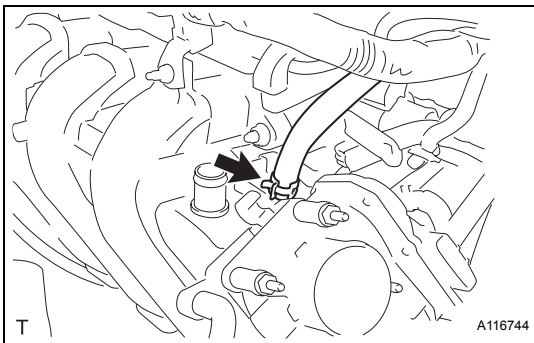
**36. DISCONNECT UNION TO CONNECTOR TUBE HOSE**

- (a) Disconnect the union to connector tube hose.

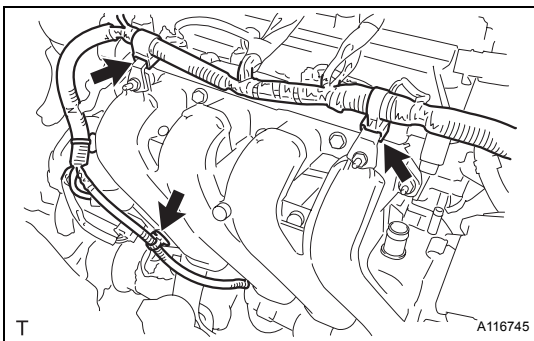
37. REMOVE OIL LEVEL GAUGE SUB-ASSEMBLY**38. REMOVE INTAKE MANIFOLD**

- (a) Separate the 3 wire harness clamps shown in the illustration.

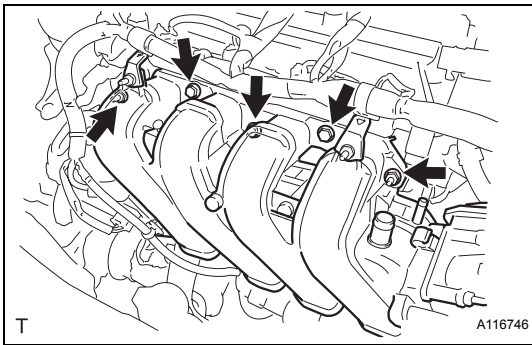

- (b) Remove the 3 bolts and 2 nuts and remove the intake manifold.

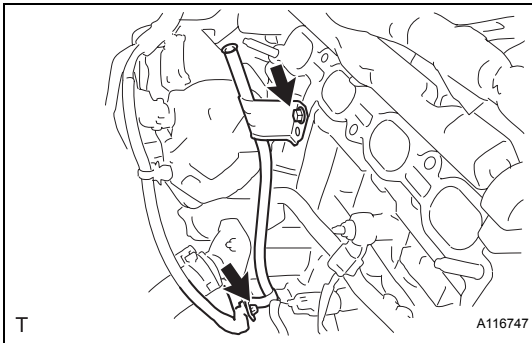

39. REMOVE OIL LEVEL GAUGE GUIDE

- (a) Remove the wire harness clamp and the bolt and remove the oil level gauge guide.

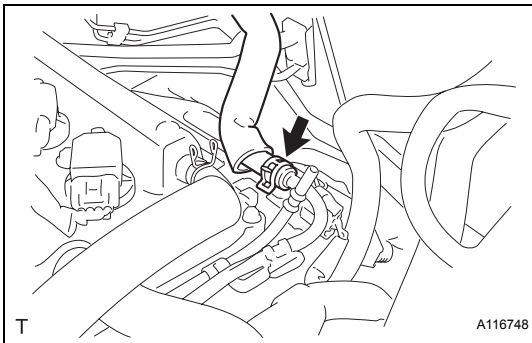

41. DISCONNECT BOOSTER VACUUM TUBE

- (a) Disconnect the booster vacuum tube.

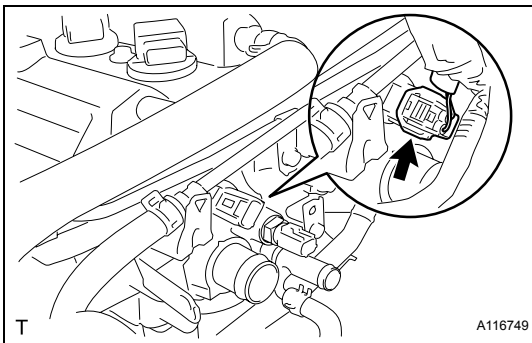

42. DISCONNECT CAMSHAFT POSITION SENSOR CONNECTOR

- (a) Disconnect the camshaft position sensor connector.

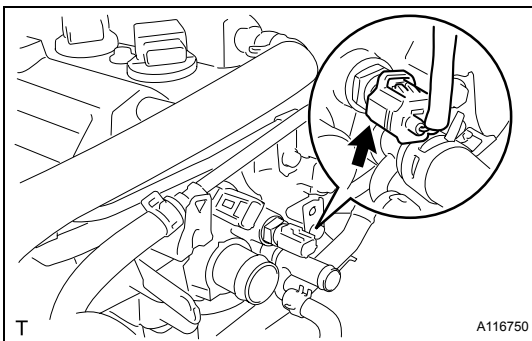

43. DISCONNECT ENGINE COOLANT TEMPERATURE SENSOR CONNECTOR

- (a) Disconnect the engine coolant temperature sensor connector.

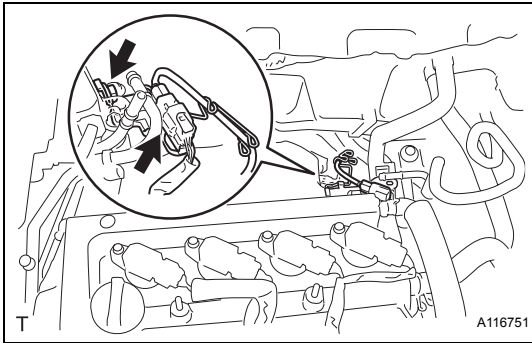

44. DISCONNECT HEATED OXYGEN SENSOR CONNECTOR

- (a) Remove the bolts and separate the sensor bracket.
- (b) Disconnect the heated oxygen sensor connector.

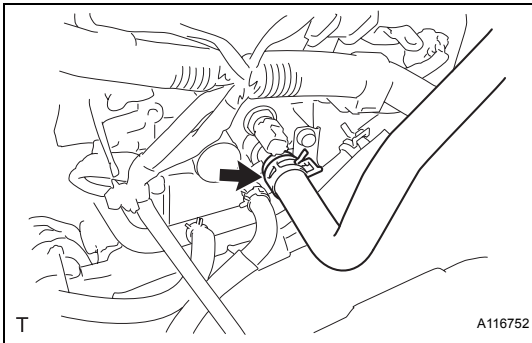

45. DISCONNECT HEATER WATER INLET HOSE A

- (a) Disconnect heater water inlet hose A.

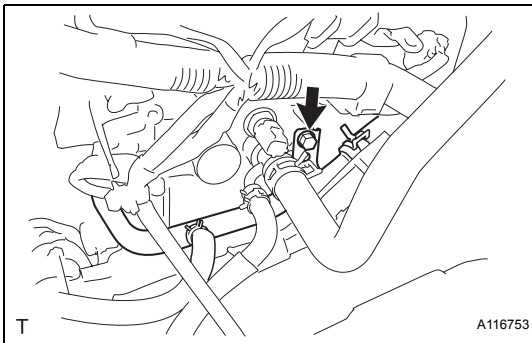

46. SEPARATE WATER BY-PASS PIPE NO. 1

- (a) Remove the bolt and separate water by-pass pipe No. 1.

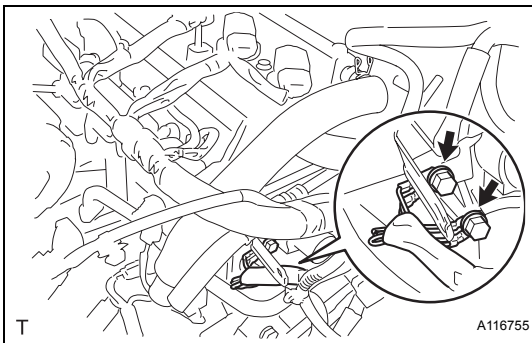

47. DISCONNECT WIRE HARNESS

- (a) Remove the 2 bolts and disconnect the wire harness.

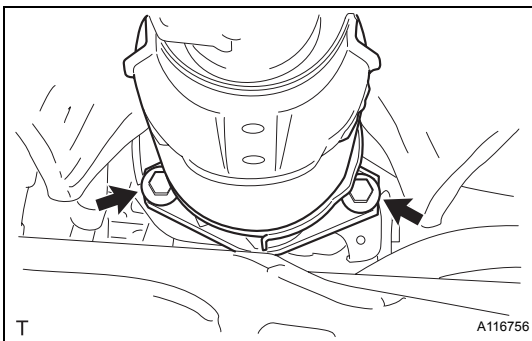

48. SEPARATE EXHAUST PIPE ASSEMBLY FRONT

- (a) Remove the 2 bolts and 2 compression springs and separate the exhaust pipe assembly front.

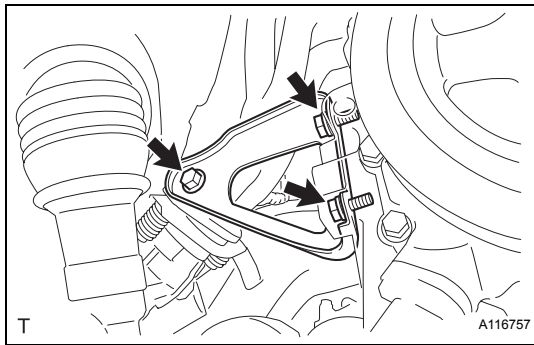

49. **REMOVE MANIFOLD SUPPORT BRACKET**
(a) Remove the 3 bolts and remove the manifold support bracket.
50. **REMOVE FAN AND GENERATOR V BELT** (See page [EM-7](#))
51. **REMOVE GENERATOR ASSEMBLY** (See page [CH-10](#))
52. **REMOVE IGNITION COIL NO. 1** (See page [IG-9](#))
53. **REMOVE VENTILATION HOSE** (See page [FU-13](#))
54. **REMOVE VENTILATION HOSE NO. 2** (See page [FU-13](#))
55. **REMOVE CYLINDER HEAD COVER SUB-ASSEMBLY** (See page [FU-13](#))
56. **REMOVE ENGINE MOUNTING INSULATOR SUB-ASSEMBLY RH** (See page [LU-17](#))
57. **REMOVE CRANKSHAFT DAMPER SUB-ASSEMBLY** (See page [LU-18](#))
58. **REMOVE CRANKSHAFT POSITION SENSOR** (See page [ES-403](#))
59. **REMOVE CAMSHAFT TIMING OIL CONTROL VALVE ASSEMBLY** (See page [ES-396](#))
60. **REMOVE WATER PUMP PULLEY** (See page [CO-15](#))
61. **REMOVE WATER PUMP ASSEMBLY** (See page [CO-15](#))
62. **REMOVE TRANSVERSE ENGINE ENGINE MOUNTING BRACKET** (See page [LU-17](#))
63. **REMOVE OIL PUMP ASSEMBLY** (See page [LU-19](#))
64. **REMOVE OIL PUMP SEAL** (See page [LU-21](#))
65. **REMOVE CHAIN TENSIONER ASSEMBLY NO. 1** (See page [EM-33](#))
66. **REMOVE CHAIN TENSIONER SLIPPER** (See page [EM-35](#))
67. **REMOVE CHAIN VIBRATION DAMPER NO. 1** (See page [EM-35](#))
68. **REMOVE CHAIN SUB-ASSEMBLY**
69. **REMOVE CAMSHAFT**
NOTICE:
When rotating the camshaft with the timing chain removed, rotate the crankshaft counterclockwise 40° from the TDC first.

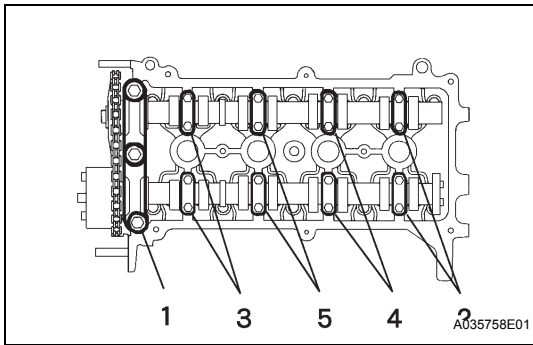

- (a) Using several steps, uniformly loosen and remove the 19 bearing cap bolts in the sequence shown in the illustration, and then remove camshaft bearing cap No. 1 and camshaft bearing cap No. 2.

NOTICE:

Loosen each bolt uniformly while keeping the camshaft level.

- (b) Remove the camshaft and camshaft No. 2.

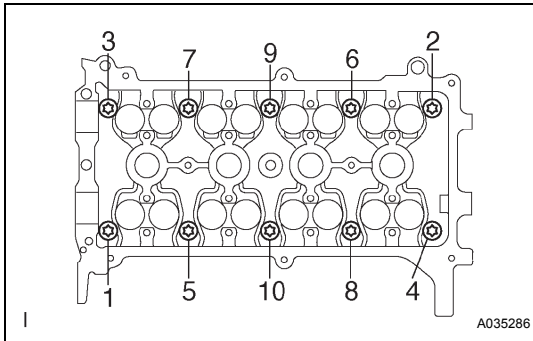
**70. REMOVE CYLINDER HEAD SUB-ASSEMBLY**

- (a) Using several steps, uniformly loosen and remove the 10 cylinder head bolts with an 8 mm bi-hexagon wrench in the sequence shown in the illustration. Remove the 10 plate washers.

NOTICE:

- Do not drop the washers into the cylinder head.
- Head warpage or cracking could result from removing the bolts in the wrong order.

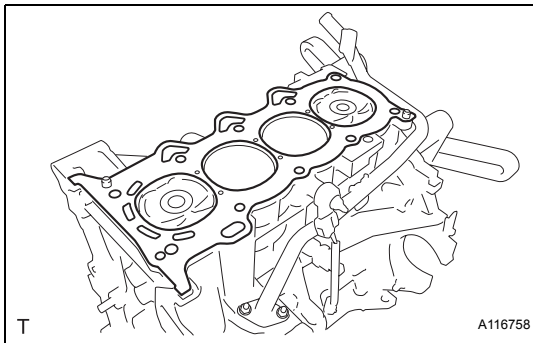
**71. REMOVE CYLINDER HEAD GASKET**

- (a) Remove the cylinder head gasket.

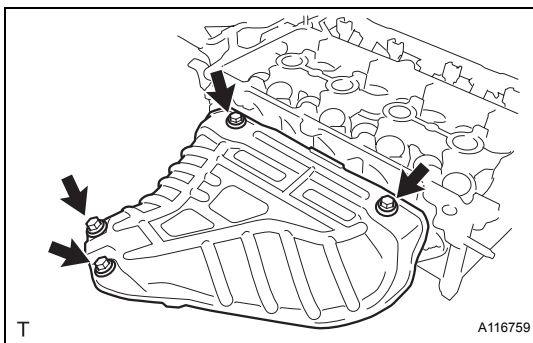
**72. REMOVE EXHAUST MANIFOLD HEAT INSULATOR NO. 1**

- (a) Remove the 4 bolts and remove exhaust manifold heat insulator No. 1.

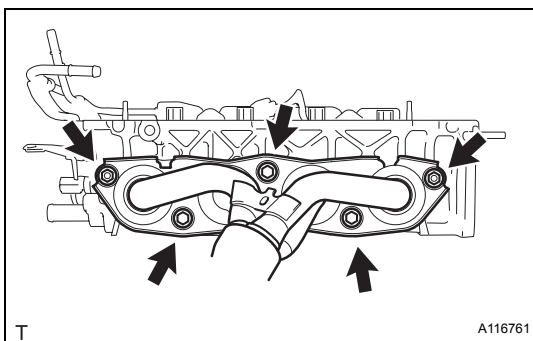
**73. REMOVE EXHAUST MANIFOLD**

- (a) Remove the 3 bolts and 2 nuts and remove the exhaust manifold.

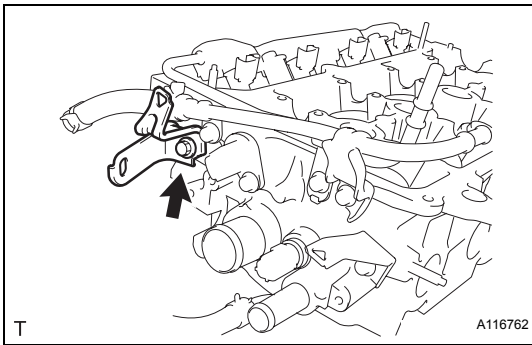
**74. REMOVE HARNESS BRACKET**

- (a) Remove the bolt and remove the harness bracket.

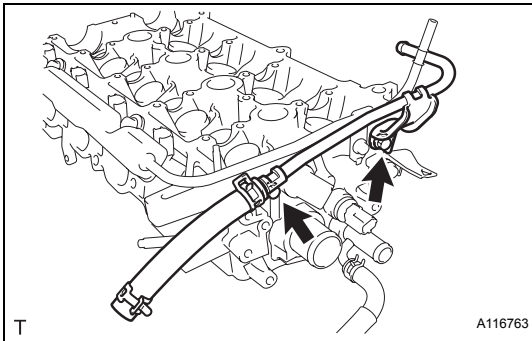
**75. REMOVE BOOSTER VACUUM TUBE**

- (a) Remove the 2 bolts and remove the booster vacuum tube.

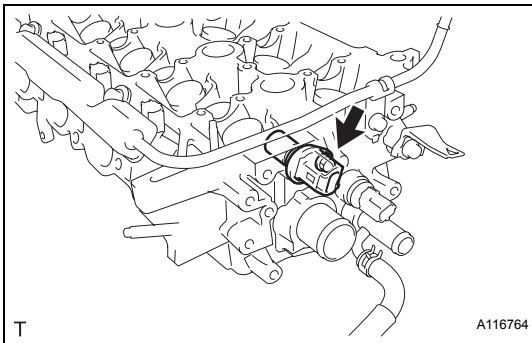
**76. REMOVE CAMSHAFT POSITION SENSOR**

- (a) Remove the bolt and remove the camshaft position sensor.

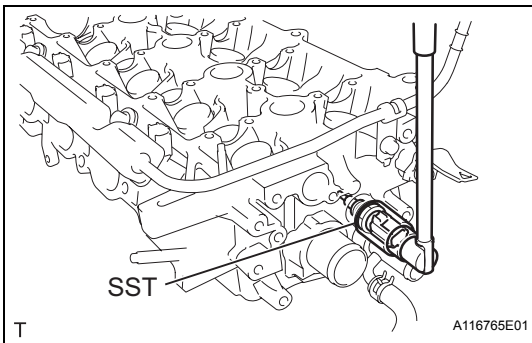
**77. REMOVE ENGINE COOLANT TEMPERATURE SENSOR**

- (a) Using SST, remove the engine coolant temperature sensor connector.

SST 09817-33190

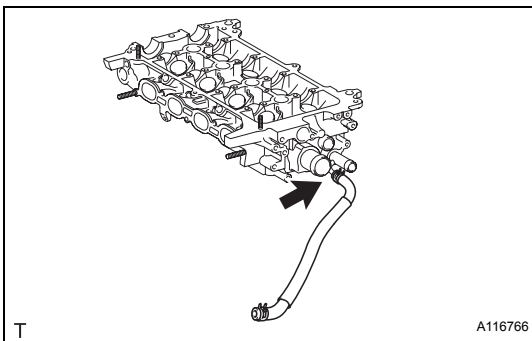
**78. REMOVE WATER BY-PASS HOSE**

- (a) Remove the water by-pass hose.

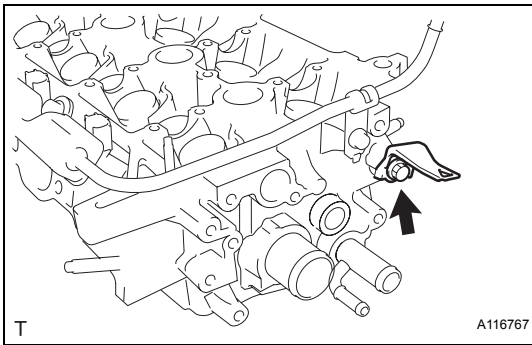
**79. REMOVE HARNESS BRACKET**

- (a) Remove the bolt and remove the harness bracket.

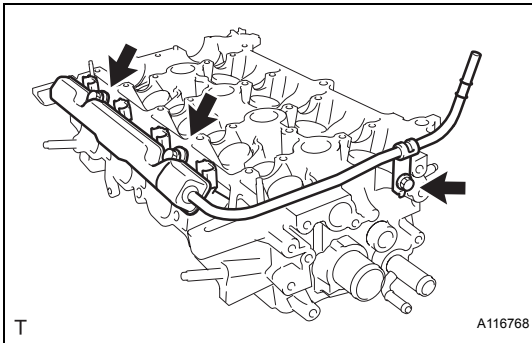
**80. REMOVE FUEL DELIVERY PIPE SUB-ASSEMBLY**

- (a) Remove the 3 bolts and remove the fuel delivery pipe sub-assembly with 4 fuel injectors.

NOTICE:

Do not drop the fuel injectors when removing the fuel delivery pipe sub-assembly.

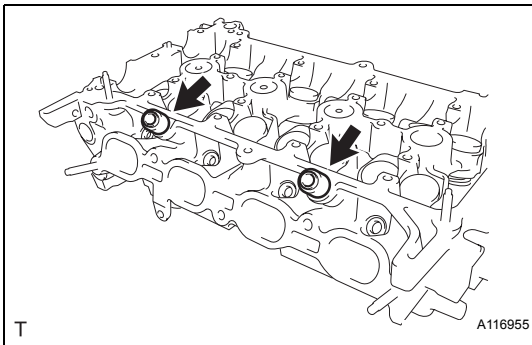
81. REMOVE FUEL INJECTOR ASSEMBLY (See page FU-16)**82. REMOVE DELIVERY PIPE NO. 1 SPACER**

- (a) Remove the 2 delivery pipe No. 1 spacers.

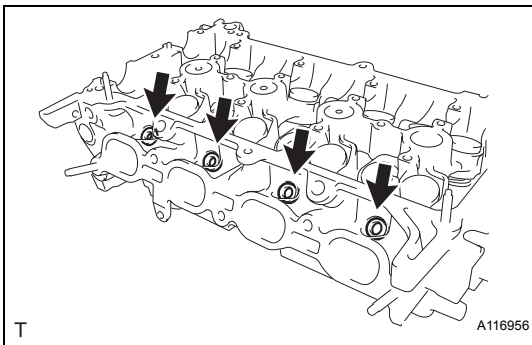
**83. REMOVE INJECTOR VIBRATION INSULATOR**

- (a) Remove the 4 injector vibration insulators.

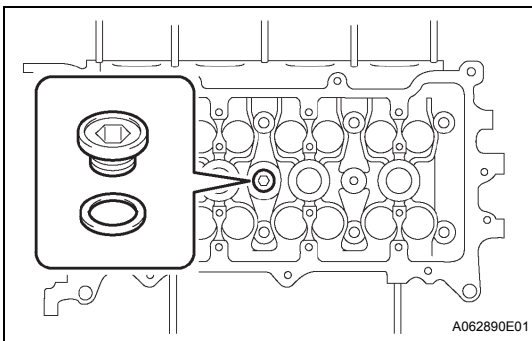
**DISASSEMBLY****1. REMOVE WITH HEAD TAPER SCREW PLUG NO. 1**

- (a) Using a 10 mm socket hexagon wrench, remove the taper screw plug and the gasket.

2. REMOVE VALVE LIFTER**HINT:**

Keep the valve lifters in the correct order so that they can be returned to their original locations when reassembled.

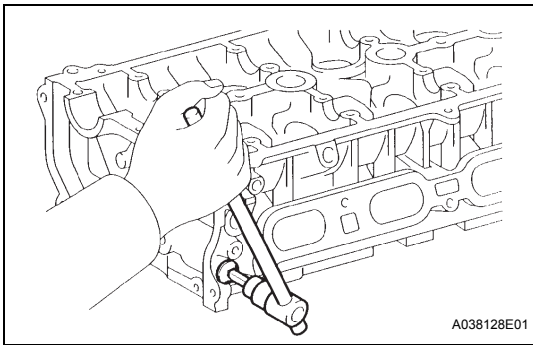

- 3. REMOVE WITH HEAD TAPER SCREW PLUG NO. 2**
 (a) Using an 8 mm hexagon wrench, remove the taper screw plug.

4. REMOVE OIL CONTROL VALVE FILTER

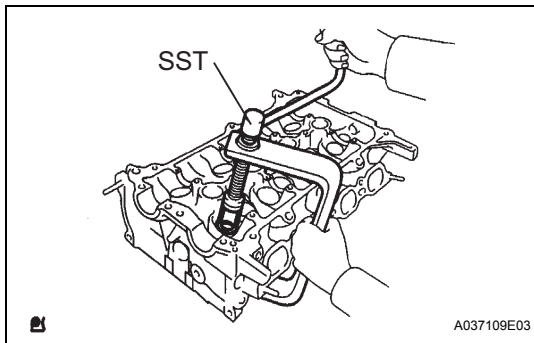

5. REMOVE INTAKE VALVE

- (a) Using SST, compress the valve spring and remove the 2 retainer locks, retainer and valve spring.

SST 09202-70020 (09202-00010)

HINT:

Keep the valves, valve springs, spring seats and spring retainers in the correct order so that they can be returned to their original locations when reassembled.

6. REMOVE EXHAUST VALVE

- (a) Using SST, compress the valve spring and remove the 2 retainer locks, retainer and valve spring.

SST 09202-70020 (09202-00010)

HINT:

Keep the valves, valve springs, spring seats and spring retainers in the correct order so that they can be returned to their original locations when reassembled.

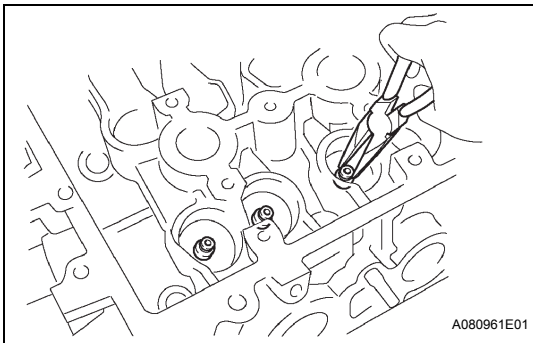

7. REMOVE VALVE STEM OIL SEAL

- (a) Using needle-nose pliers, remove the oil seal.

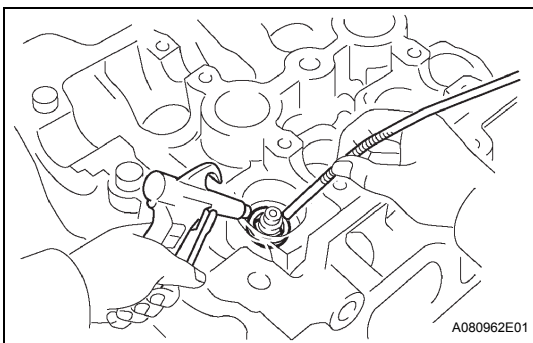

8. REMOVE VALVE SPRING SEAT

- (a) Using compressed air and a magnetic finger, remove the valve spring seats.

9. REMOVE STUD BOLT

- (a) Using "Torx" socket wrenches E5 and E7, remove the 7 stud bolts.

10. REMOVE CAMSHAFT BEARING CAP SETTING RING PIN

INSPECTION

1. INSPECT CYLINDER HEAD FOR WARPAGE

- (a) Using a precision straightedge and feeler gauge, measure the warpage of the surface that is in contact with the cylinder block and the manifolds.

Maximum warpage

Surface	Specified Condition
Cylinder block side	0.05 mm (0.0020 in.)
Intake manifold side	0.10 mm (0.0039 in.)
Exhaust manifold side	0.10 mm (0.0039 in.)

If the warpage is greater than the maximum, replace the cylinder head.

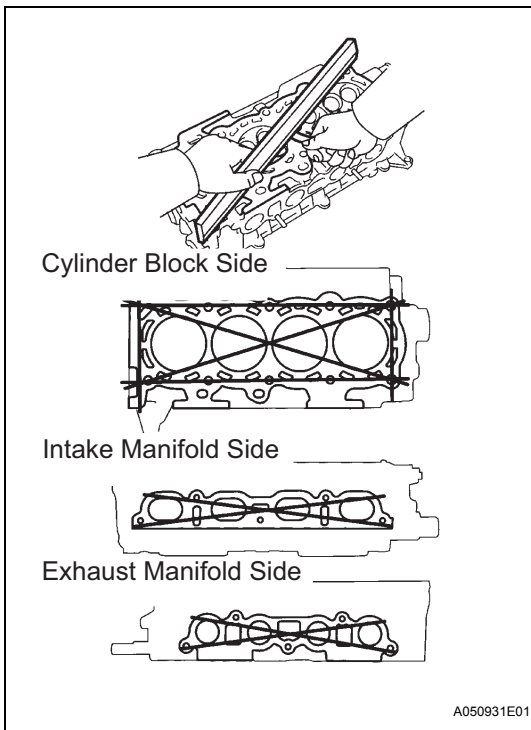

2. INSPECT CYLINDER HEAD FOR CRACKS

- (a) Using a dye penetrate, check the combustion chamber, intake ports, exhaust ports and cylinder block surface for cracks.

If cracked, replace the cylinder head.

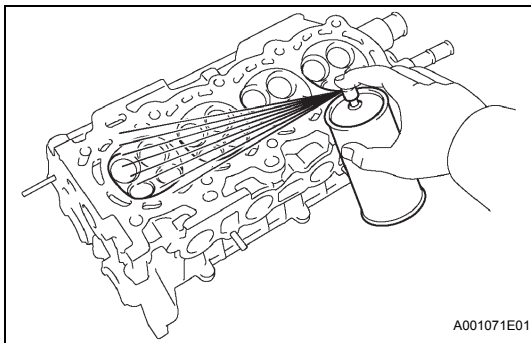

3. INSPECT CYLINDER HEAD SET BOLT

- (a) Using vernier calipers, measure the length of the head bolts from the seat to the end.

Standard length:

142.8 to 144.2 mm (5.622 to 5.677 in.)

Maximum length:

147.1 mm (5.791 in.)

If the length is greater than the maximum, replace the bolt.

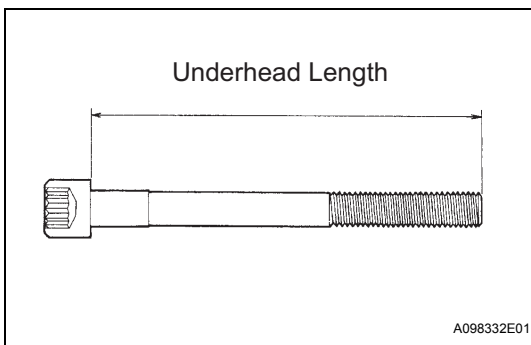

4. INSPECT INTAKE VALVE

- (a) Check the overall valve length.

Standard overall length:

89.25 mm (3.5138 in.)

Minimum overall length:

88.75 mm (3.4941 in.)

If the overall length is less than the minimum, replace the valve.

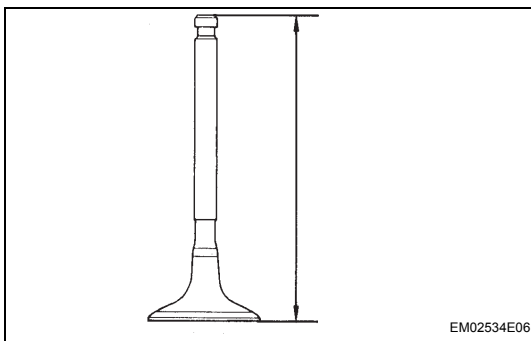

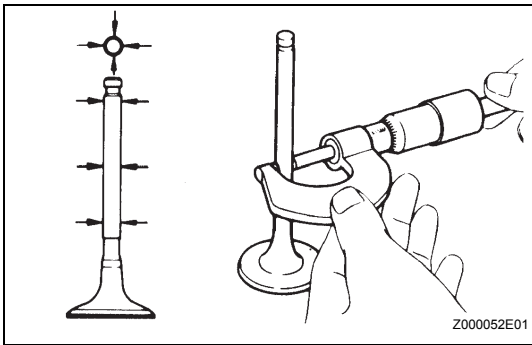

- (b) Using a micrometer, measure the diameter of the valve stem.

Standard valve stem diameter:

4.970 to 4.985 mm (0.1957 to 0.1963 in.)

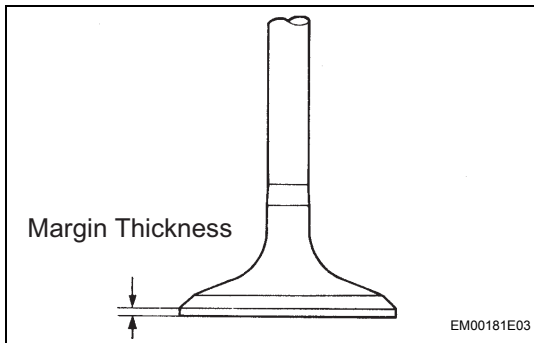

- (c) Check the valve head margin thickness.

Standard margin thickness:

1.0 mm (0.039 in.)

Minimum margin thickness:

0.5 mm (0.020 in.)

If the margin thickness is less than the minimum, replace the valve.

5. INSPECT EXHAUST VALVE

- (a) Check the overall valve length.

Standard overall length:

87.90 mm (3.4606 in.)

Minimum overall length:

87.40 mm (3.4409 in.)

If the overall length is less than the minimum, replace the valve.

- (b) Using a micrometer, measure the diameter of the valve stem.

Standard valve stem diameter:

4.965 to 4.980 mm (0.1955 to 0.1961 in.)

- (c) Check the valve head margin thickness.

Standard margin thickness:

1.15 mm (0.045 in.)

Minimum margin thickness:

0.5 mm (0.020 in.)

If the margin thickness is less than the minimum, replace the valve.

6. INSPECT VALVE SPRING

- (a) Using vernier calipers, measure the free length of the valve spring.

Standard free length:

45.05 to 45.15 mm (1.774 to 1.778 in.)

If the free length is not as specified, replace the spring.

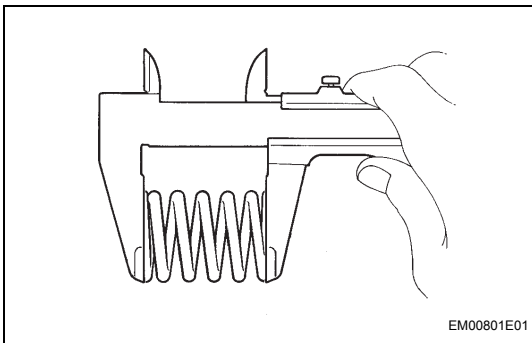

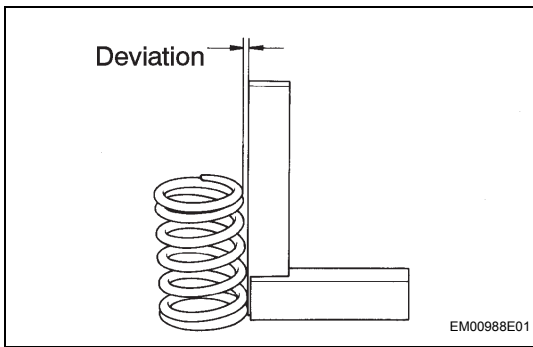

- (b) Using a steel square, measure the deviation of the valve spring.

Maximum deviation:

1.6 mm (0.063 in.)

Maximum angle (reference):

2°

If the deviation is greater than the maximum, replace the spring.

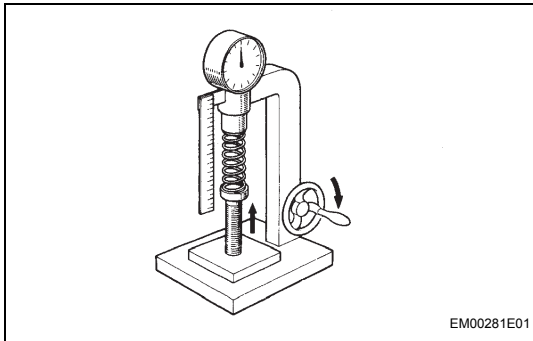

- (c) Using a spring tester, measure the tension of the valve spring at the specified installed length.

Standard installed tension:

**149 to 165 N (15.2 to 16.8 kgf, 33.5 to 37.1 lbf)
at 32.5 mm (1.280 in.)**

Maximum working tension:

**286 to 316 N (29.1 to 32.2 kgf, 64.2 to 71.0 lbf)
at 23.9 mm (0.941 in.)**

If the installed tension is not as specified, replace the valve spring.

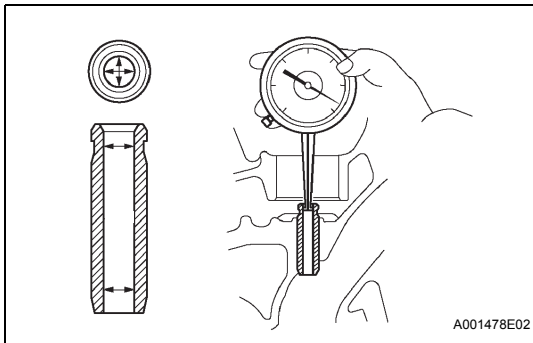

7. INSPECT VALVE GUIDE BUSH OIL CLEARANCE

- (a) Using a caliper gauge, measure the inside diameter of the guide bush.

Bush inside diameter:

5.010 to 5.030 mm (0.1972 to 0.1980 in.)

- (b) Subtract the valve stem diameter measurement from the guide bush inside diameter measurement to calculate the oil clearance.

Standard oil clearance

Guide Bush	Specified Condition
Intake	0.025 to 0.060 mm (0.0010 to 0.0024 in.)
Exhaust	0.030 to 0.065 mm (0.0012 to 0.0026 in.)

Maximum oil clearance

Guide Bush	Specified Condition
Intake	0.08 mm (0.0032 in.)
Exhaust	0.10 mm (0.0039 in.)

If the clearance is greater than the maximum, replace the valve and guide bush (see page [EM-92](#)).

8. INSPECT INTAKE VALVE SEAT

- (a) Apply a light coat of prussian blue to the valve face.
(b) Lightly press the valve against the seat.

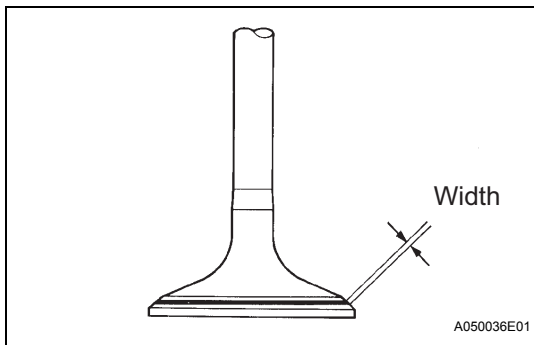

- (c) Check the valve face and seat in accordance with the following procedure.
- (1) If blue appears 360° around the face, the valve is concentric. If not, replace the valve.
 - (2) If blue appears 360° around the valve seat, the guide and face are concentric. If not, resurface the seat.
 - (3) Check that the seat contact is in the middle of the valve face with the width between 1.0 to 1.4 mm (0.039 to 0.055 in.).

9. INSPECT VALVE LIFTER

- (a) Using a micrometer, measure the lifter diameter.

Standard lifter diameter:

30.966 to 30.976 mm (1.2191 to 1.2195 in.)

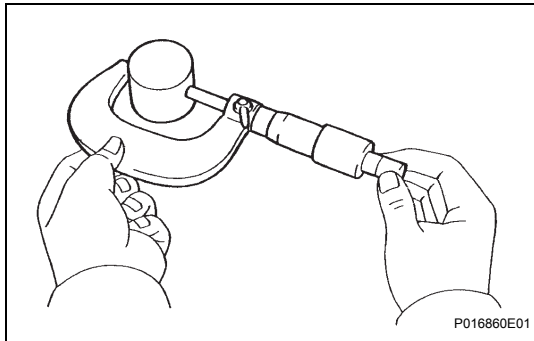

10. INSPECT VALVE LIFTER OIL CLEARANCE

- (a) Using a caliper gauge, measure the lifter bore diameter of the cylinder head.

Standard lifter bore diameter:

31.000 to 31.025 mm (1.2205 to 1.2215 in.)

- (b) Subtract the lifter diameter measurement from the lifter bore diameter measurement to calculate the oil clearance.

Standard oil clearance:

0.024 to 0.059 mm (0.0009 to 0.0023 in.)

Maximum oil clearance:

0.1 mm (0.0039 in.)

If the oil clearance is greater than the maximum, replace the lifter. If necessary, replace the cylinder head.

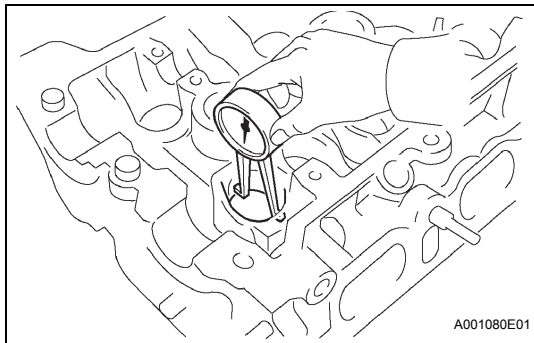

11. INSPECT CAMSHAFT

- (a) Inspect the camshaft for runout.

- (1) Place the camshaft on V-blocks.

- (2) Using a dial indicator, measure the circle runout at the center journal.

Maximum circle runout:

0.03 mm (0.0012 in.)

If the circle runout is greater than the maximum, replace the camshaft.

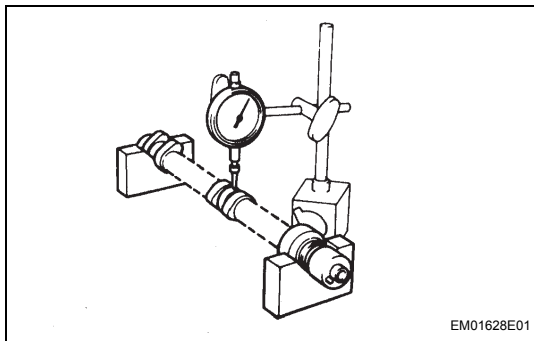

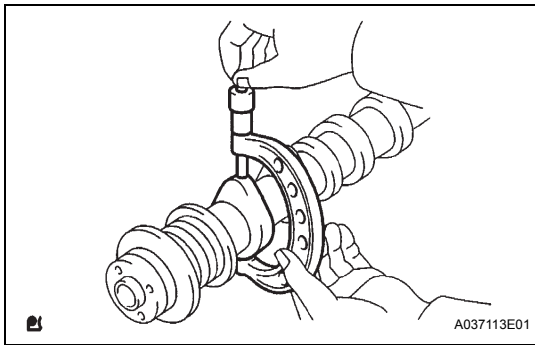

- (b) Inspect the cam lobes.
 - (1) Using a micrometer, measure the cam lobe height.

Standard cam lobe height:
44.617 to 44.717 mm (1.7566 to 1.7605 in.)

Minimum cam lobe height:
43.16 mm (1.6992 in.)

 If the cam lobe height is less than the minimum, replace the camshaft.

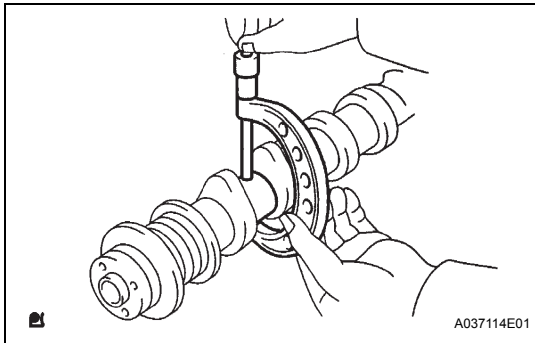

- (c) Inspect the camshaft journals.
 - (1) Using a micrometer, measure the journal diameter.

Standard journal diameter

Journal	Specified Condition
No. 1 journal	34.449 to 34.465 mm (1.3563 to 1.3569 in.)
Other journals	22.949 to 22.965 mm (0.9035 to 0.9041 in.)

If the journal diameter is not as specified, check the oil clearance.

12. INSPECT NO. 2 CAMSHAFT

- (a) Inspect the camshaft for runout.
 - (1) Place the camshaft on V-blocks.
 - (2) Using a dial indicator, measure the circle runout at the center journal.

Maximum circle runout:
0.03 mm (0.0012 in.)

 If the circle runout is greater than the maximum, replace the camshaft.

- (b) Inspect the cam lobes.
 - (1) Using a micrometer, measure the cam lobe height.

Standard cam lobe height:
44.666 to 44.766 (1.7585 to 1.7624 in.)

Minimum cam lobe height:
44.52 mm (1.7528 in.)

 If the cam lobe height is less than the minimum, replace the camshaft.

- (c) Inspect the camshaft journals.
 - (1) Using a micrometer, measure the journal diameter.

Standard journal diameter

Journal	Specified Condition
No. 1 journal	34.449 to 34.465 mm (1.3563 to 1.3569 in.)
Other journals	22.949 to 22.965 mm (0.9035 to 0.9041 in.)

If the journal diameter is not as specified, check the oil clearance.

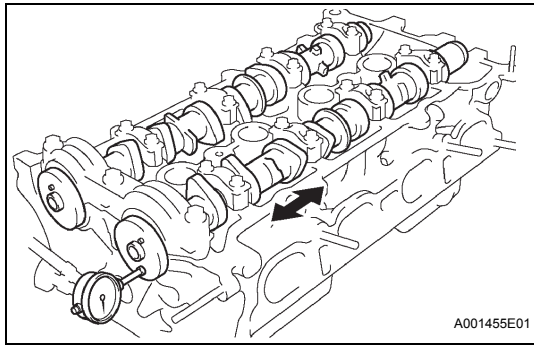

13. INSPECT CAMSHAFT THRUST CLEARANCE

- (a) Install the camshafts.
- (b) Using a dial indicator, measure the thrust clearance while moving the camshaft back and forth.

Standard thrust clearance:

0.040 to 0.095 mm (0.0016 to 0.0037 in.)

Maximum thrust clearance:

0.11 mm (0.0043 in.)

If the thrust clearance is greater than the maximum, replace the camshaft. If necessary, replace the bearing caps and the cylinder head together.

14. INSPECT CAMSHAFT OIL CLEARANCE

- (a) Clean the bearing caps and the camshaft journals.
- (b) Place the camshafts on the cylinder head.

- (c) Lay a strip of Plastigage across each of the camshaft journals.

- (d) Install the bearing caps (see page [EM-97](#)).

NOTICE:

Do not turn the camshaft.

- (e) Remove the bearing caps.

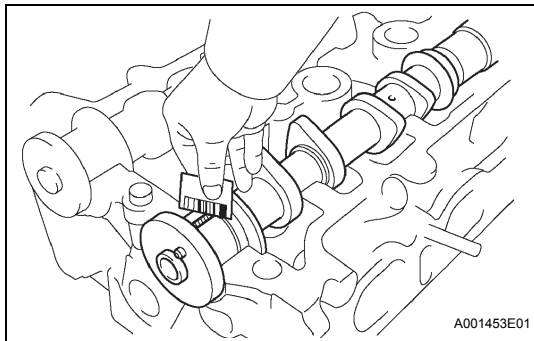
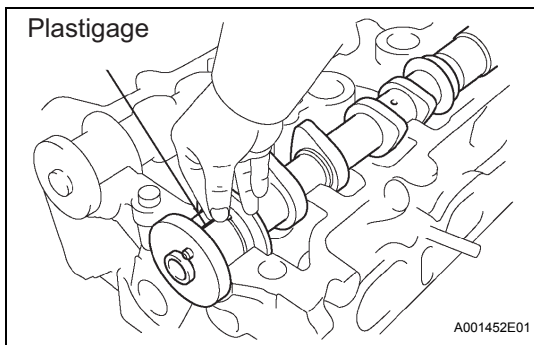

- (f) Measure the Plastigage at its widest point.

Standard oil clearance:

0.035 to 0.072 mm (0.0014 to 0.0028 in.)

Maximum oil clearance:

0.08 mm (0.0031 in.)

If the oil clearance is greater than the maximum, replace the camshaft. If necessary, replace the bearing caps and the cylinder head together.

NOTICE:

Completely remove the Plastigage after the measurement.

REPLACEMENT

1. REMOVE INTAKE VALVE GUIDE BUSH

- (a) Heat the cylinder head to 80 to 100°C (176 to 212°F).

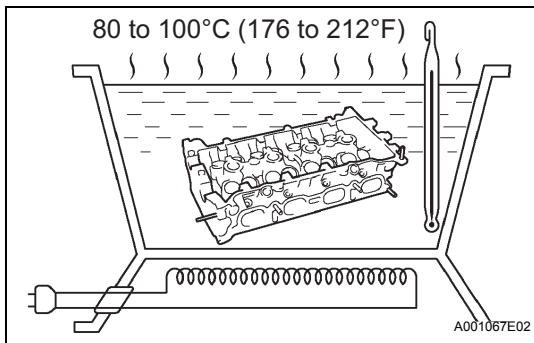

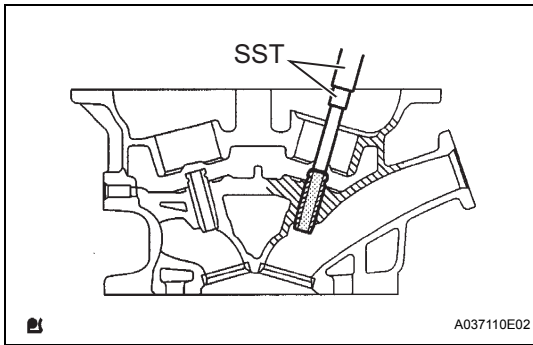

- (b) Using SST and a hammer, tap out the guide bushing.

SST 09201-10000 (09201-01050), 09950-70010 (09951-07100)

2. REMOVE EXHAUST VALVE GUIDE BUSH

- (a) Heat the cylinder head to 80 to 100°C (176 to 212°F).

- (b) Using SST and a hammer, tap out the guide bushing.

SST 09201-10000 (09201-01050), 09950-70010 (09951-07100)

3. INSTALL INTAKE VALVE GUIDE BUSH

- (a) Using a caliper gauge, measure the bushing bore diameter of the cylinder head.

Inside Diameter:

9.685 to 9.706 mm (0.3813 to 0.3821 in.)

If the bushing bore diameter of the cylinder head is greater than 9.706 mm (0.3821 in.), machine the bushing bore to the dimension of 9.735 to 9.755 mm (0.3833 to 0.3841 in.).

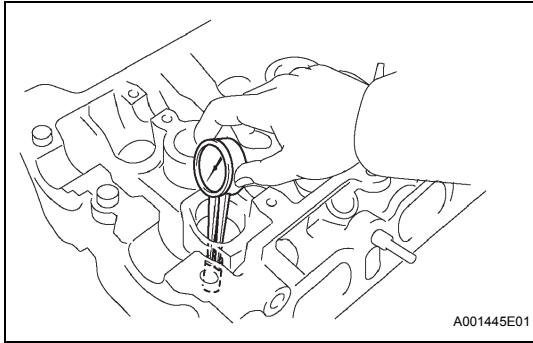

Bushing bore diameter mm (in.)	Bushing size
9.685 to 9.706 (0.3813 to 0.3821)	STD
9.735 to 9.755 (0.3833 to 0.3841)	O/S 0.05

- (b) Heat the cylinder head to 80 to 100°C (176 to 212°F).

- (c) Using SST and a hammer, tap a new guide bushing in to the specified protrusion height.

SST 09201-10000 (09201-01050), 09950-70010 (09951-07100)

Protrusion height:

9.0 to 9.4 mm (0.354 to 0.370 in.)

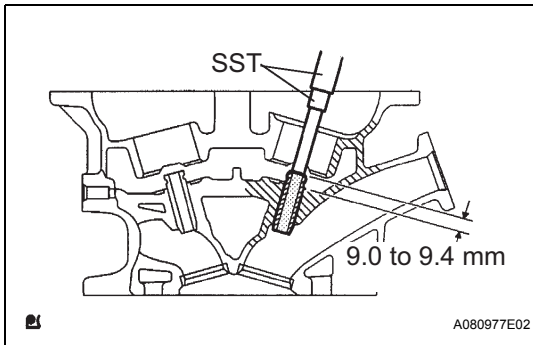

- (d) Using a sharp 5 mm reamer, ream the guide bushing to obtain the standard oil clearance between the guide bushing and valve stem.

Standard oil clearance:

0.025 to 0.060 mm (0.0010 to 0.0024 in.)

4. INSTALL EXHAUST VALVE GUIDE BUSH

- (a) Using a caliper gauge, measure the bushing bore diameter of the cylinder head.

Inside Diameter:

9.685 to 9.706 mm (0.3813 to 0.3821 in.)

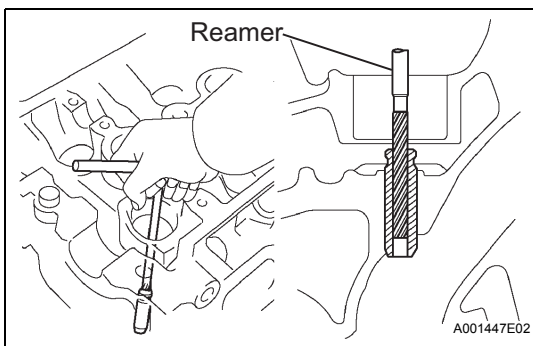

If the bushing bore diameter of the cylinder head is greater than 9.706 mm (0.3821 in.), machine the bushing bore to the dimension of 9.735 to 9.755 mm (0.3833 to 0.3841 in.).

Bushing bore diameter mm (in.)	Bushing size
9.685 to 9.706 (0.3813 to 0.3821)	STD
9.735 to 9.755 (0.3833 to 0.3841)	O/S 0.05

- (b) Heat the cylinder head to 80 to 100°C (176 to 212°F).
- (c) Using SST and a hammer, tap a new guide bushing in to the specified protrusion height.

SST 09201-10000 (09201-01050), 09950-70010 (09951-07100)

Protrusion height:

9.0 to 9.4 mm (0.354 to 0.370 in.)

- (d) Using a sharp 5 mm reamer, ream the guide bushing to obtain the standard oil clearance between the guide bushing and valve stem.

Standard oil clearance:

0.030 to 0.065 mm (0.0012 to 0.0026 in.)

REASSEMBLY

1. INSTALL CAMSHAFT BEARING CAP SETTING RING PIN

- (a) Using a plastic-faced hammer, tap a new ring pin in to the specified protrusion height.

Protrusion height:

8.5 to 9.5 mm (0.335 to 0.374 in.)

2. INSTALL STUD BOLT

- (a) Using "Torx" socket wrenches E5 and E7, install the 7 stud bolts.

Torque:

Stud bolt A:

10 N*m (102 kgf*cm, 7.4 ft.*lbf)

Stud bolt B:

4.0 N*m (41 kgf*cm, 35 in.*lbf)

Stud bolt C:

10 N*m (102 kgf*cm, 7.4 ft.*lbf)

Stud bolt D:

9.0 N*m (92 kgf*cm, 80 in.*lbf)

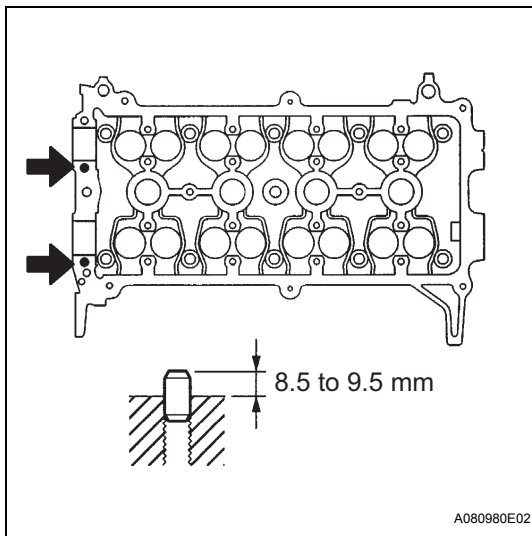

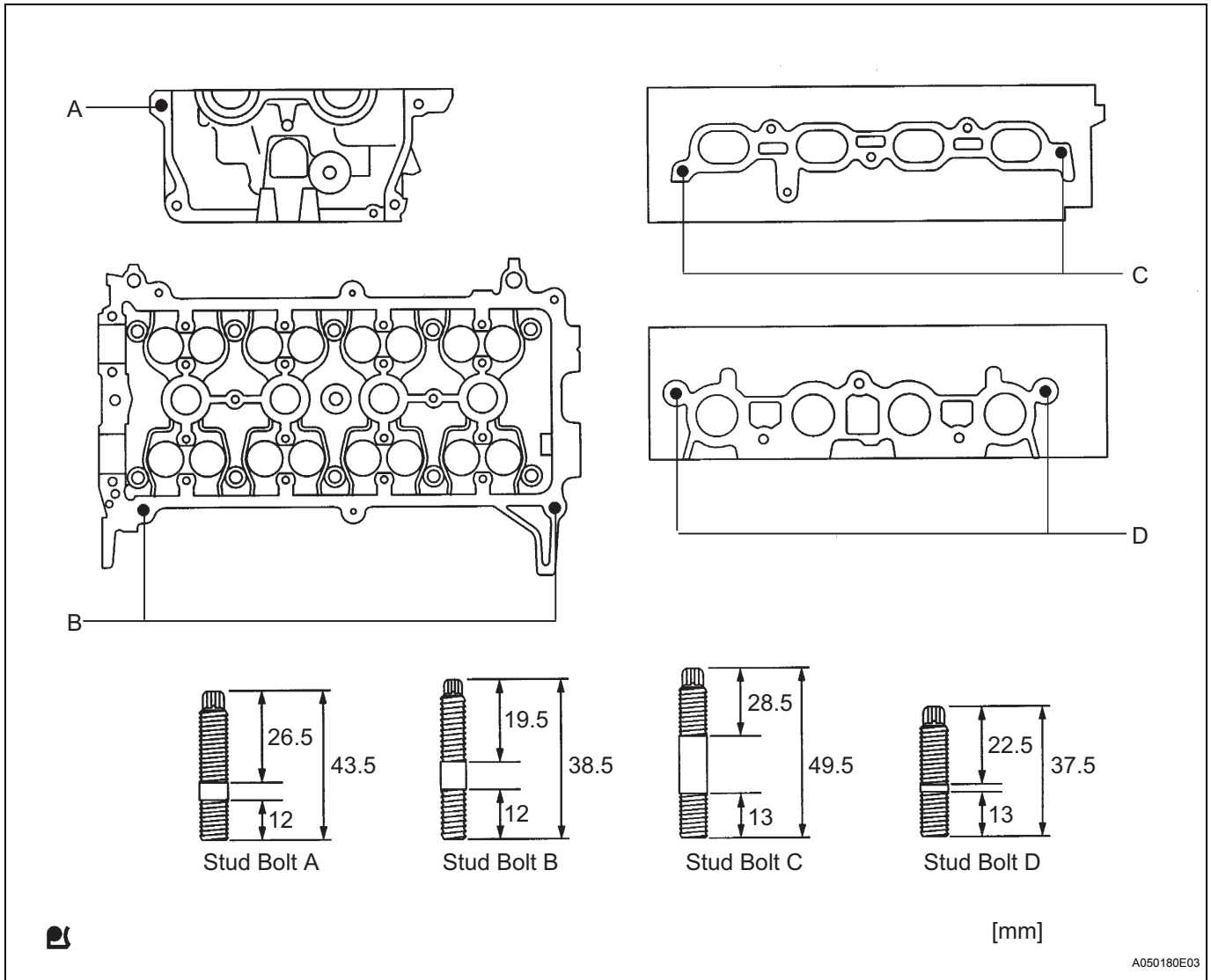

A050180E03

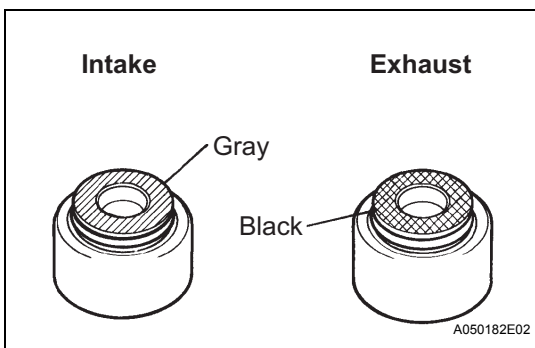

3. INSTALL VALVE STEM OIL SEAL

- (a) Apply a light coat of engine oil to new valve stem oil seals.

NOTICE:

Installing the oil seals for the intake and exhaust onto the opposite valve guide bush as may cause failures.

HINT:

The intake valve oil seal is gray and the exhaust valve oil seal is black.

- (b) Using SST, push in the oil seals.

SST 09201-41020

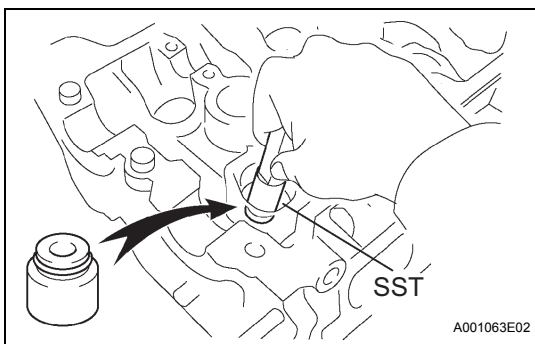

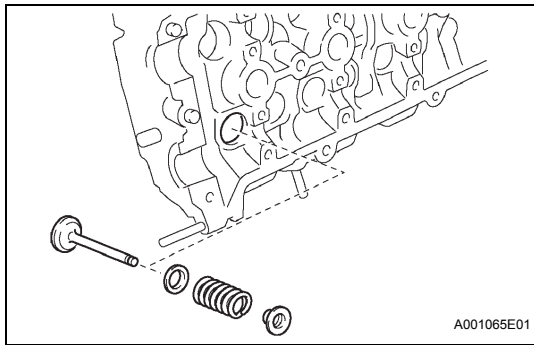

4. INSTALL INTAKE VALVE

- (a) Install the valve, spring seat, valve spring, and spring retainer.

NOTICE:

Install the parts in their original locations in the original order.

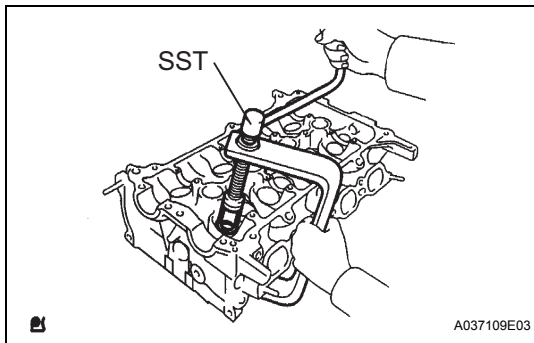

- (b) Using SST, compress the valve spring and place the 2 retainer locks around the valve stem.

SST 09202-70020 (09202-00010)

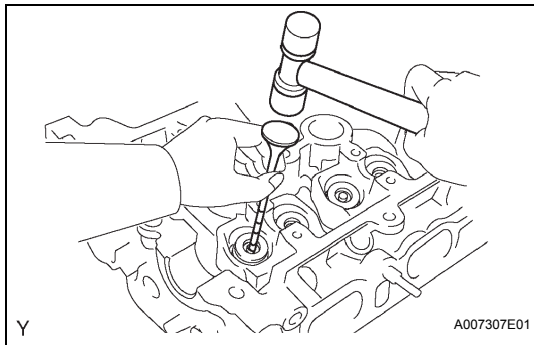

- (c) Using a plastic-faced hammer and the valve stem (not in use) with its tip wrapped in tape, gently tap the valve stem tip to ensure a proper fit.

NOTICE:

Do not damage the valve stem tip.

5. INSTALL EXHAUST VALVE

- (a) Install the valve, spring seat, valve spring, and spring retainer.

- (b) Using SST, compress the valve spring and place the 2 retainer locks around the valve stem.

SST 09202-70020 (09202-00010)

- (c) Using a plastic-faced hammer and the valve stem (not in use) with its tip wrapped in tape, lightly tap the valve stem tip to ensure a proper fit.

NOTICE:

Do not damage the valve stem tip.

6. INSTALL OIL CONTROL VALVE FILTER

- (a) Install the oil control valve filter.

7. INSTALL WITH HEAD TAPER SCREW PLUG NO. 2

- (a) Using an 8 mm hexagon wrench, install the taper screw plug and a new gasket.

Torque: 30 N*m (306 kgf*cm, 22 ft.*lbf)

8. INSTALL VALVE LIFTER

- (a) Apply a light coat of engine oil to the 16 valve lifters.
 (b) Install the 16 valve lifters.
 (c) Check that the valve lifters rotate smoothly by hand.

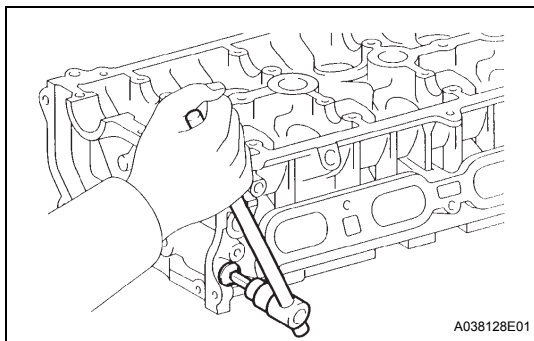

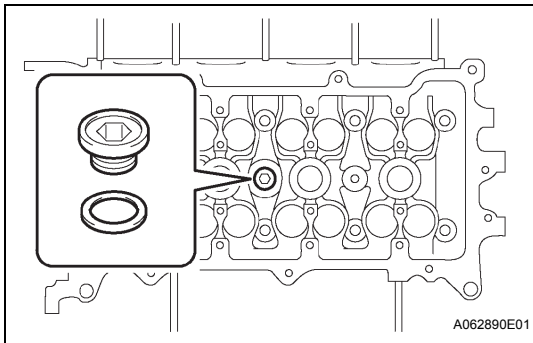

- 9. INSTALL WITH HEAD TAPER SCREW PLUG NO. 1**
 (a) Using a 10 mm socket hexagon wrench, install the taper screw plug with a new gasket.
Torque: 44 N*m (449 kgf*cm, 33 ft.*lbf)

INSTALLATION

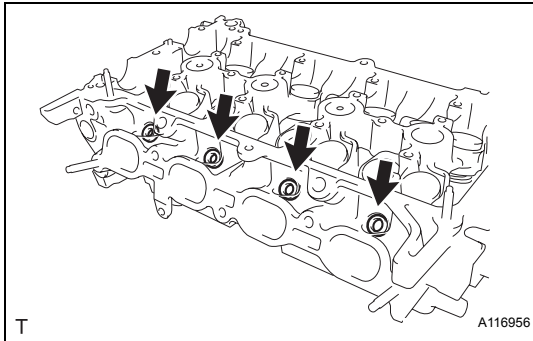

- 1. INSTALL INJECTOR VIBRATION INSULATOR**
 (a) Install 4 new injector vibration insulators onto the cylinder head.

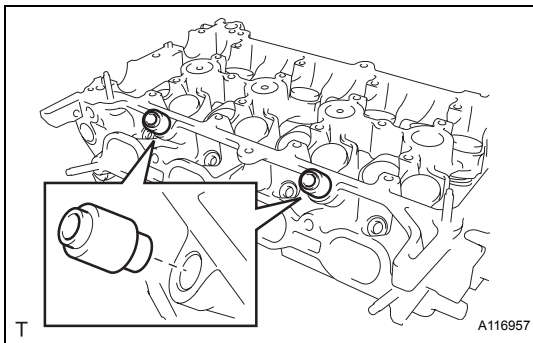

- 2. INSTALL DELIVERY PIPE NO. 1 SPACER**
 (a) Install the 2 delivery pipe No. 1 spacers onto the cylinder head.

NOTICE:

Install the delivery pipe No. 1 spacer in the correct direction.

- 3. INSTALL FUEL INJECTOR ASSEMBLY (See page [FU-17](#))**

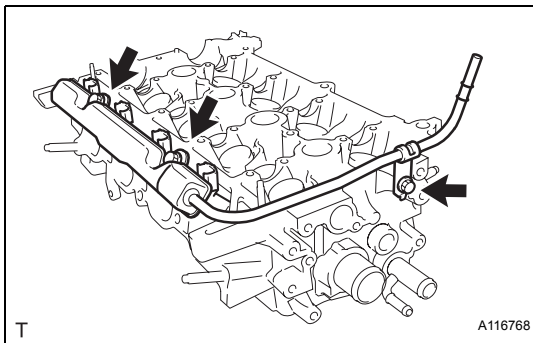

- 4. INSTALL FUEL DELIVERY PIPE SUB-ASSEMBLY**

- (a) Provisionally install the fuel delivery pipe sub-assembly with the 4 fuel injectors using the 3 bolts.

NOTICE:

- Do not drop the fuel injectors when installing the fuel delivery pipe sub-assembly.
- Check that the fuel injectors rotate smoothly after installing the fuel delivery pipe sub-assembly.

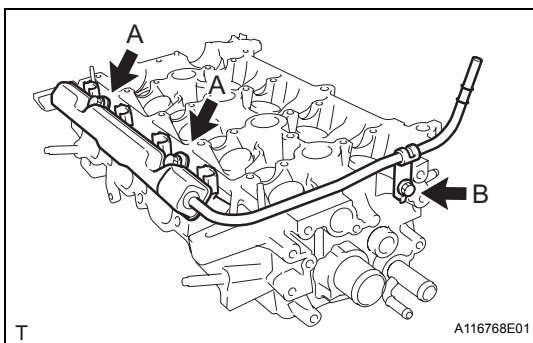

- (b) Tighten the 3 bolts to the specified torque.
Torque: 19 N*m (194 kgf*cm, 14 ft.*lbf) for bolt A
9.0 N*m (92 kgf*cm, 80 in.*lbf) for bolt B

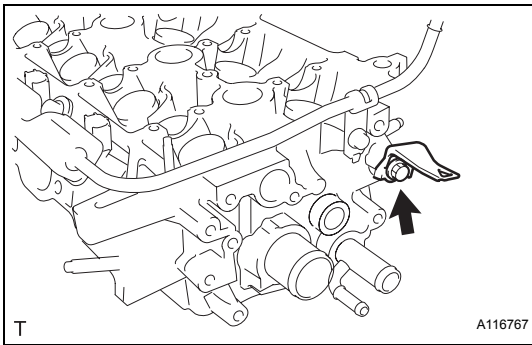
**5. INSTALL HARNESS BRACKET**

- (a) Install the harness bracket with the bolt.
Torque: 13 N*m (131 kgf*cm, 9.5 ft.*lbf)

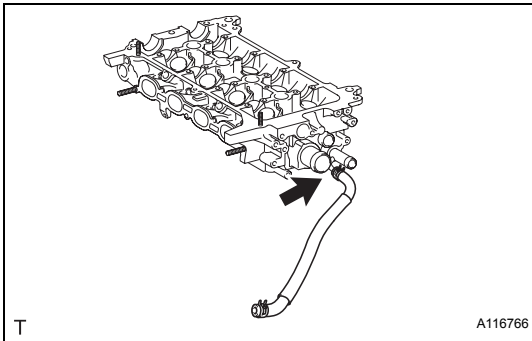
**6. INSTALL WATER BY-PASS HOSE**

- (a) Install the water by-pass hose.

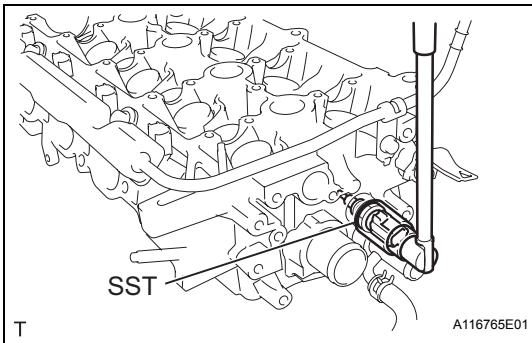
**7. INSTALL ENGINE COOLANT TEMPERATURE SENSOR**

- (a) Provisionally install the engine coolant temperature sensor through a new gasket.
 (b) Using SST, tighten the engine coolant temperature sensor.

SST 09817-33190

Torque: 20 N*m (204 kgf*cm, 15 ft.*lbf)

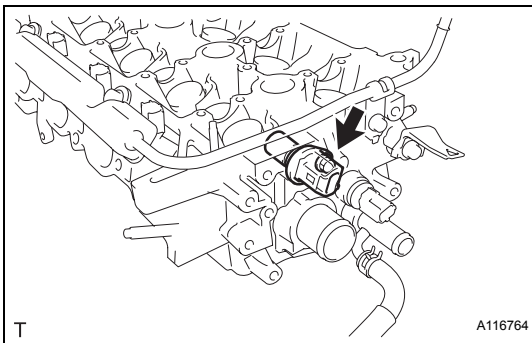
**8. INSTALL CAMSHAFT POSITION SENSOR**

- (a) Apply a light coat of engine oil to the O-ring on the camshaft position sensor.
 (b) Install the camshaft position sensor with the bolt.

Torque: 8.0 N*m (82 kgf*cm, 71 in.*lbf)

NOTICE:

Do not twist the O-ring.

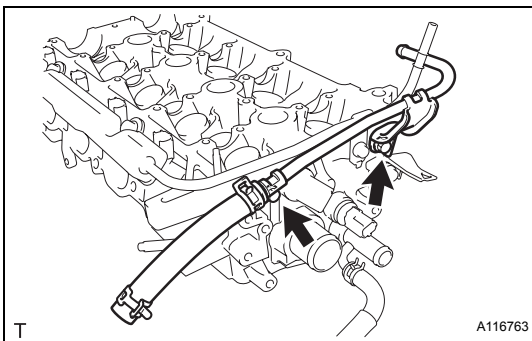
**9. INSTALL BOOSTER VACUUM TUBE**

- (a) Install the booster vacuum tube with the 2 bolts.
Torque: 9.0 N*m (92 kgf*cm, 80 in.*lbf)

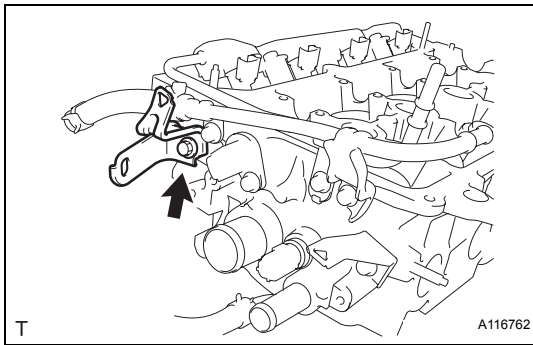
**10. INSTALL HARNESS BRACKET**

- (a) Install the harness bracket with the bolt.
Torque: 13 N*m (131 kgf*cm, 9.5 ft.*lbf)

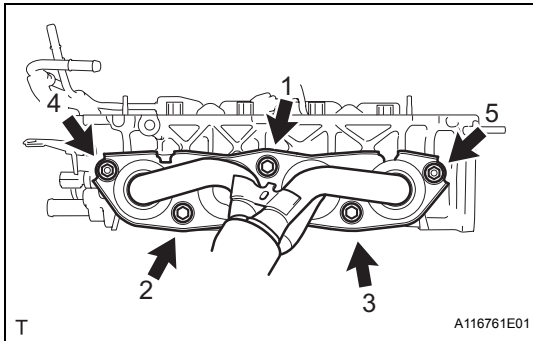
**11. INSTALL EXHAUST MANIFOLD**

- (a) Using several steps, install a new exhaust manifold gasket and the exhaust manifold with the 3 bolts and 2 nuts in the sequence shown in the illustration.
Torque: 27 N*m (275 kgf*cm, 20 ft.*lbf)

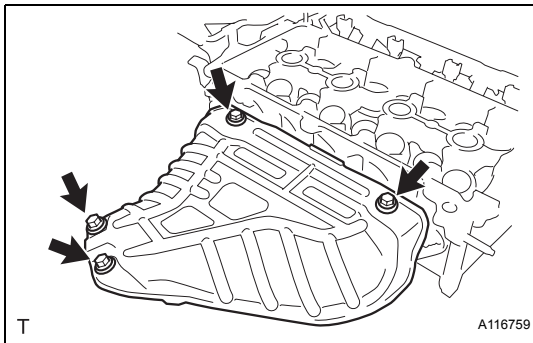
**12. INSTALL EXHAUST MANIFOLD HEAT INSULATOR NO. 1**

- (a) Install exhaust manifold heat insulator No. 1 with the 4 bolts.
Torque: 8.0 N*m (82 kgf*cm, 71 in.*lbf)

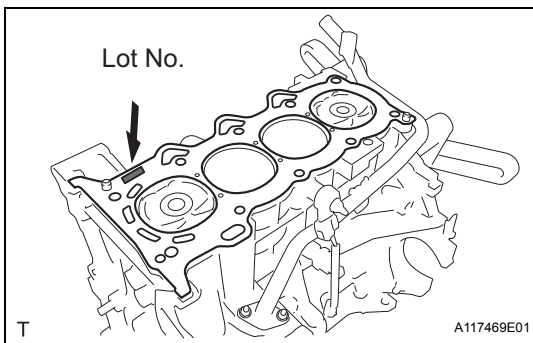
**13. INSTALL CYLINDER HEAD GASKET**

- (a) Place a new cylinder head gasket on the cylinder block with the Lot No. stamp facing upward.

NOTICE:

- Remove any oil from the contact surfaces.
- Check the mounting orientation of the cylinder head gasket.
- Place the cylinder head on the cylinder head gently in order not to damage the gasket.

14. INSTALL CYLINDER HEAD SUB-ASSEMBLY**HINT:**

The cylinder head bolts are tightened in 2 successive steps.

- (a) Apply a light coat of engine oil to the threads of the cylinder head bolts.

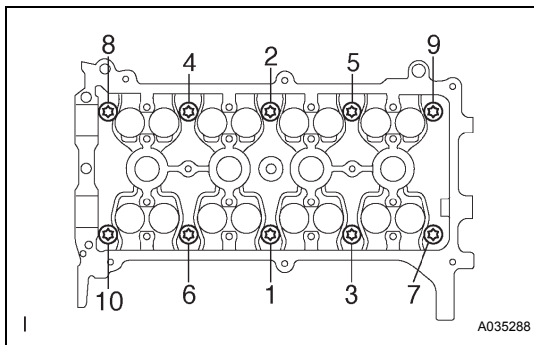

- (b) Using several steps, install and tighten the 10 cylinder head bolts and plate washers uniformly with an 8 mm bi-hexagon wrench, in the sequence shown in the illustration.

Torque: 29 N*m (300 kgf*cm, 22 ft.*lbf)

- (c) Mark the front of the cylinder head bolt with paint.

- (d) Retighten the cylinder head bolts 90° and then an additional by 90° as shown in the illustration.

- (e) Check that the paint mark is now at a 180° angle from the front.

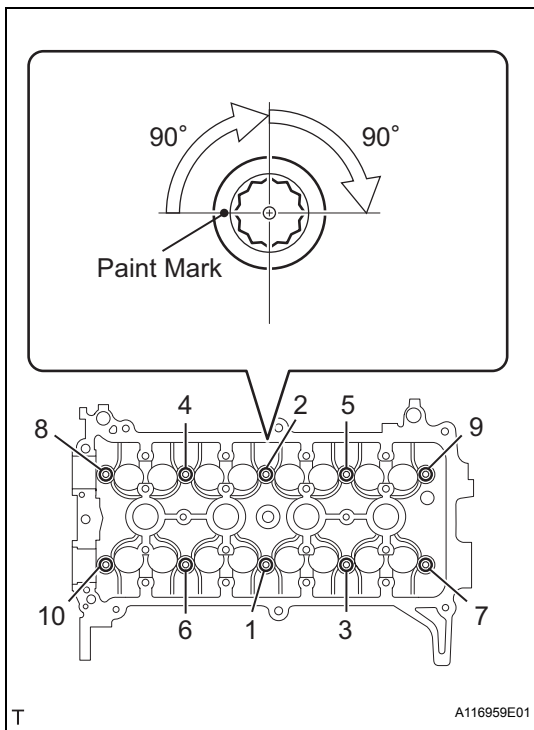

- (f) Apply a continuous bead of seal packing (Diameter 4.5 to 5.5 mm (0.177 to 0.217 in.)) as shown in the illustration.

Seal Packing:

Toyota Genuine Seal Packing Black, Three Bond 1207B or Equivalent

NOTICE:

- Remove any oil from the contact surfaces.
- Install the oil pump assembly within 3 minutes and tighten the bolts within 15 minutes of applying the seal packing.

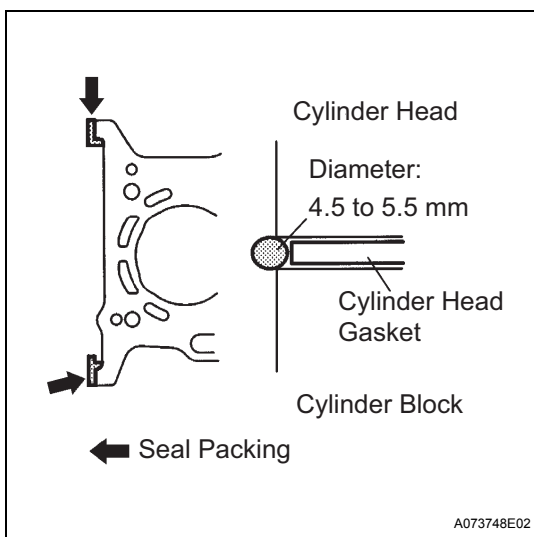

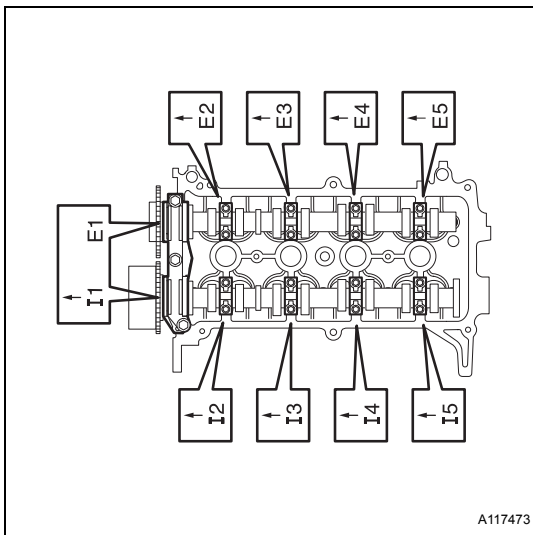

15. INSTALL CAMSHAFT

- (a) Examine the front marks and numbers and check that the sequence is as shown in the illustration. Then provisionally tighten the 19 bolts.

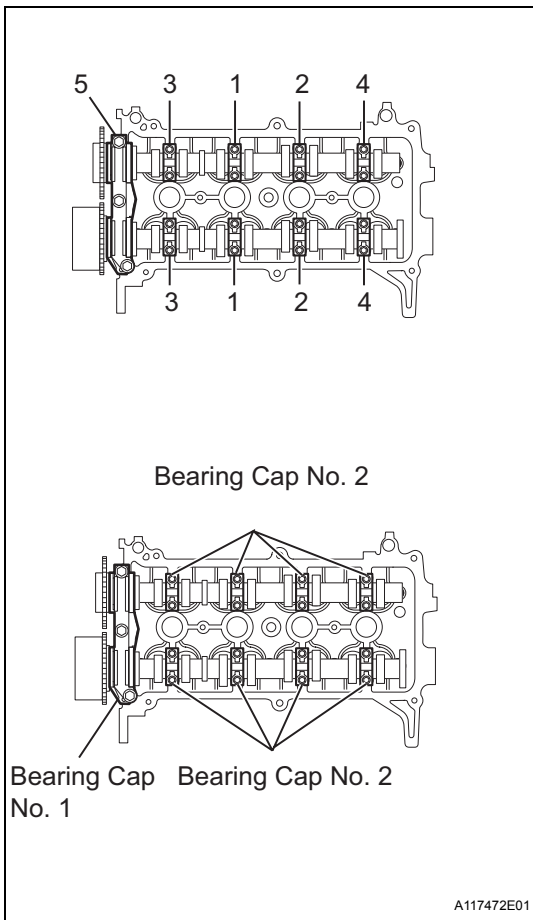

- (b) Uniformly tighten the bolts in several steps in the sequence shown in the illustration and install camshaft bearing cap No. 1 and camshaft bearing cap No. 2.

Torque: Camshaft bearing cap No. 1
 23 N*m (235 kgf*cm, 17 ft.*lbf)
Camshaft bearing cap No. 2
 13 N*m (129 kgf*cm, 9.4 ft.*lbf)

NOTICE:

Tighten each bolt uniformly while keeping the camshaft level.

16. INSTALL CHAIN SUB-ASSEMBLY (See page [EM-36](#))
17. INSTALL CHAIN TENSIONER SLIPPER (See page [EM-38](#))
18. INSTALL CHAIN TENSIONER ASSEMBLY NO. 1 (See page [EM-38](#))
19. INSTALL OIL PUMP SEAL (See page [LU-21](#))
20. INSTALL OIL PUMP ASSEMBLY (See page [LU-22](#))
21. INSTALL TRANSVERSE ENGINE ENGINE MOUNTING BRACKET (See page [LU-26](#))
22. INSTALL WATER PUMP ASSEMBLY (See page [CO-16](#))
23. INSTALL WATER PUMP PULLEY (See page [CO-16](#))
24. INSTALL CAMSHAFT TIMING OIL CONTROL VALVE ASSEMBLY (See page [ES-397](#))
25. INSTALL CRANKSHAFT POSITION SENSOR (See page [ES-403](#))
26. INSTALL CRANKSHAFT DAMPER SUB-ASSEMBLY (See page [LU-26](#))
27. INSTALL ENGINE MOUNTING INSULATOR SUB-ASSEMBLY RH (See page [LU-26](#))

28. INSTALL CYLINDER HEAD COVER SUB-ASSEMBLY (See page [FU-19](#))
29. INSTALL VENTILATION HOSE NO. 2 (See page [FU-20](#))
30. INSTALL VENTILATION HOSE (See page [FU-20](#))
31. INSTALL IGNITION COIL NO. 1 (See page [IG-9](#))
32. INSTALL GENERATOR ASSEMBLY (See page [CH-17](#))
33. INSTALL FAN AND GENERATOR V BELT (See page [EM-7](#))
34. ADJUST FAN AND GENERATOR V BELT (See page [EM-7](#))
35. INSPECT FAN AND GENERATOR V BELT (See page [EM-8](#))
36. INSTALL MANIFOLD SUPPORT BRACKET
 - (a) Install the manifold support bracket with the 3 bolts.
Torque: 44 N*m (449 kg*cm, 33 ft.*lbf)

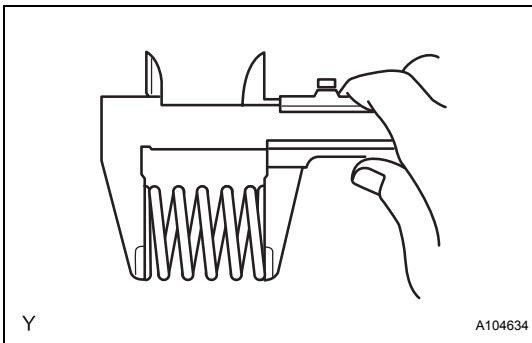
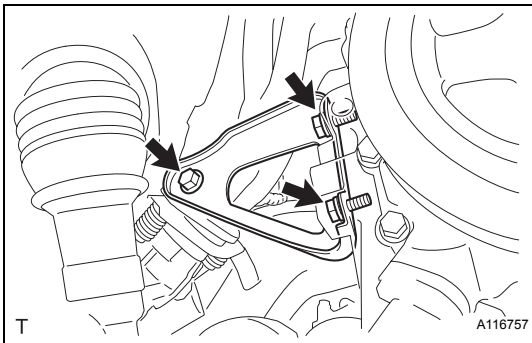

37. INSTALL EXHAUST PIPE ASSEMBLY FRONT

- (a) Using vernier calipers, measure the free length of the compression spring.

Minimum length:

40.5 mm (1.594 in.)

If the length is not as specified, replace the compression spring.

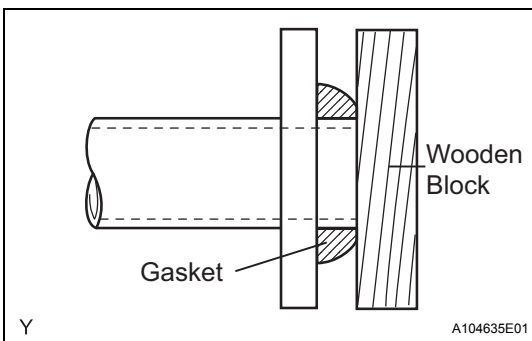

- (b) Using a plastic hammer and a wooden block, tap in a new exhaust pipe gasket until its surface is flush with the exhaust manifold.

NOTICE:

- Install the exhaust pipe gasket in the correct direction.
- Do not damage the outer surface of the exhaust pipe gasket.
- Do not reuse the exhaust pipe gasket.
- Do not push in the gasket with the exhaust pipe when installing.

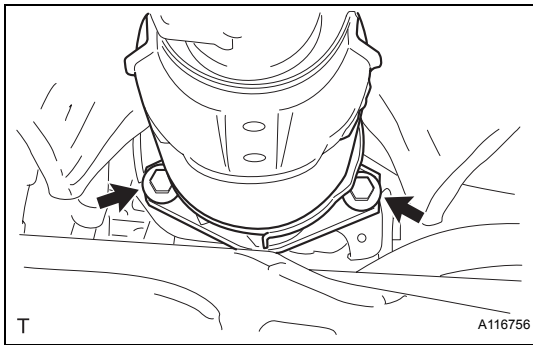

- (c) Install the exhaust front pipe assembly with the 2 compression springs and 2 bolts.
Torque: 43 N*m (439 kgf*cm, 32 ft.*lbf)

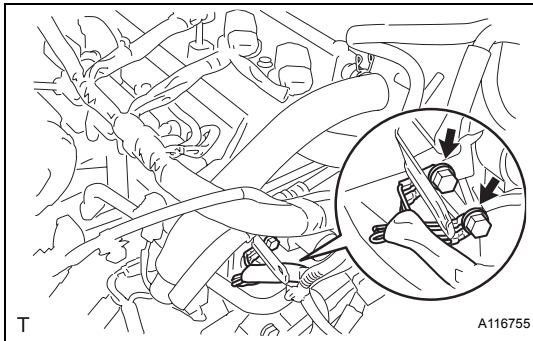

38. CONNECT WIRE HARNESS

- (a) Connect the wire harness with the 2 bolts.
Torque: 13 N*m (133 kgf*cm, 10 ft.*lbf)

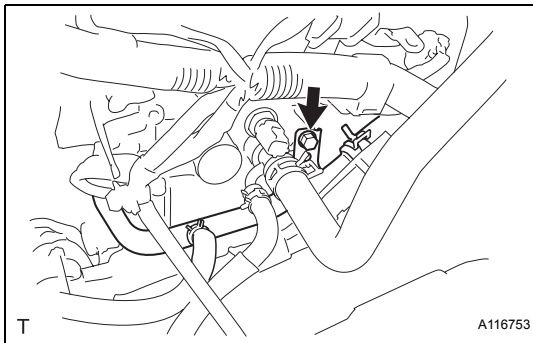

39. INSTALL WATER BY-PASS HOSE NO. 1

- (a) Install water by-pass pipe No. 1 with the bolt.
Torque: 9.0 N*m (92 kgf*cm, 80 in.*lbf)

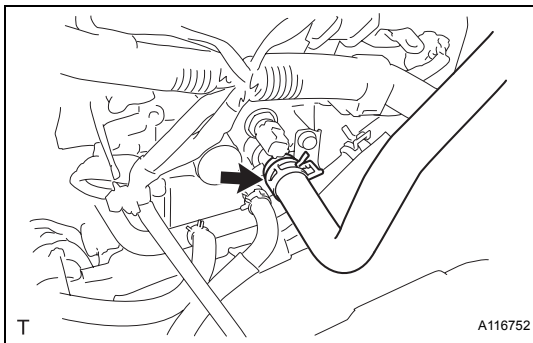

40. CONNECT HEATER WATER INLET HOSE A

- (a) Connect heater water inlet hose A.

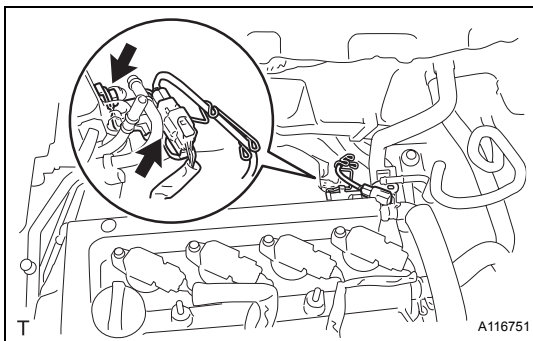

41. CONNECT HEATED OXYGEN SENSOR CONNECTOR

- (a) Connect the heated oxygen sensor connector.
 (b) Install the sensor bracket with the bolt.

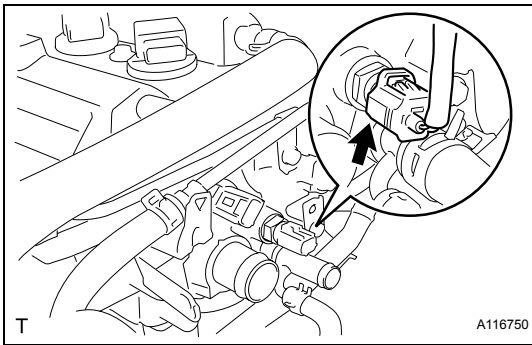

42. CONNECT ENGINE COOLANT TEMPERATURE SENSOR CONNECTOR

- (a) Connect the engine coolant temperature sensor connector.

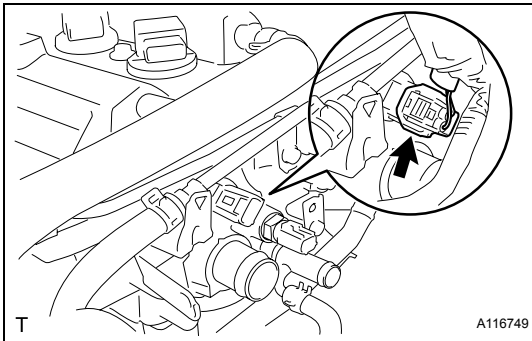

43. CONNECT CAMSHAFT POSITION SENSOR CONNECTOR

- (a) Connect the camshaft position sensor connector.

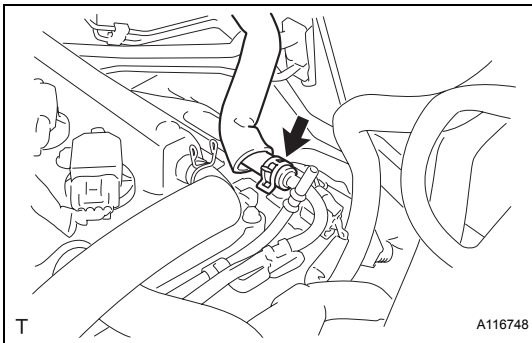

44. CONNECT BOOSTER VACUUM TUBE

- (a) Connect the booster vacuum tube.

45. CONNECT FUEL TUBE SUB-ASSEMBLY (See page [FU-18](#))

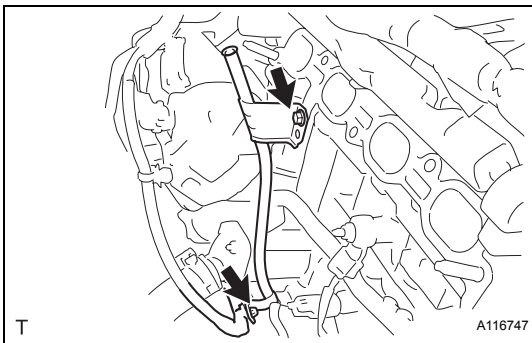

46. INSTALL OIL LEVEL GAUGE GUIDE

- (a) Apply engine oil to a new O-ring.
 (b) Install the oil level gauge guide with the bolt through a new O-ring.
Torque: 9.0 N*m (92 kgf*cm, 80 in.*lbf)
 (c) Install the wire harness.

47. INSTALL INTAKE MANIFOLD

- (a) Install a new gasket onto the intake manifold.

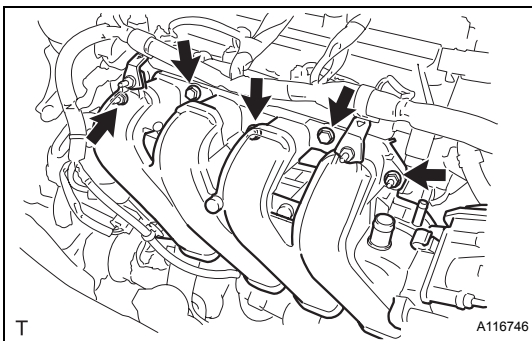

- (b) Install the intake manifold with the 3 bolts and 2 nuts.

Torque: 30 N*m (306 kgf*cm, 22 ft.*lbf)

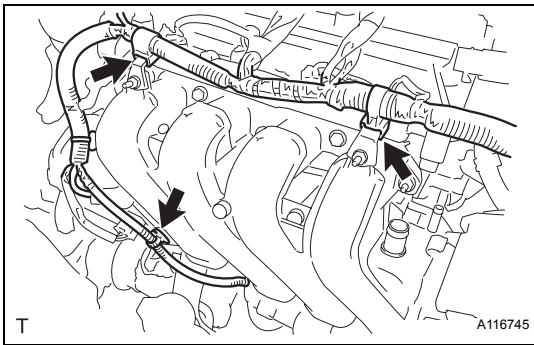

- (c) Connect the 3 wire harness clamps shown in the illustration.

48. INSTALL OIL LEVEL GAUGE SUB-ASSEMBLY

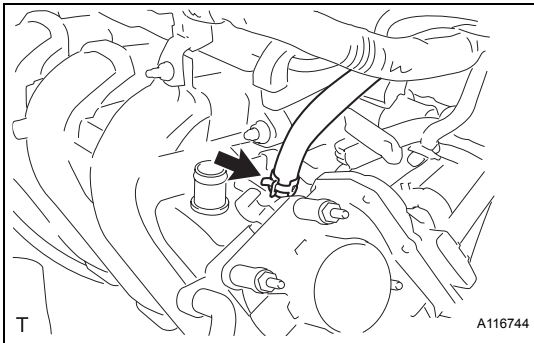

49. CONNECT UNION TO CONNECTOR TUBE HOSE

- (a) Connect the union to connector tube hose.

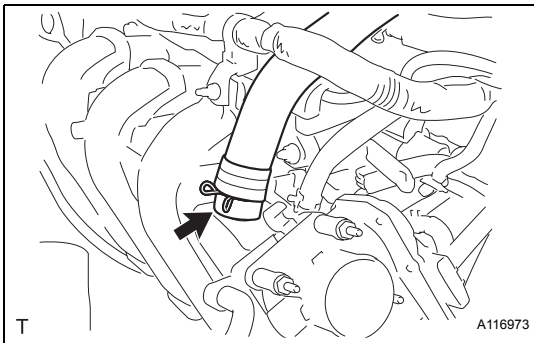

50. CONNECT VENTILATION HOSE

- (a) Connect the ventilation hose.

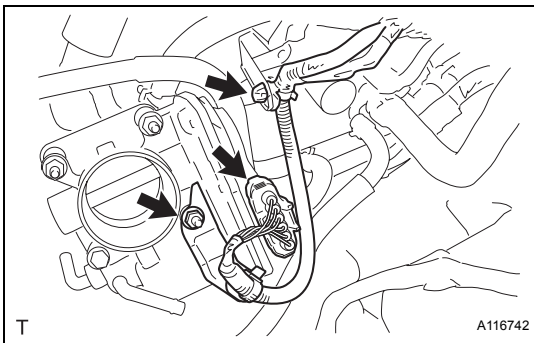

51. CONNECT THROTTLE WITH MOTOR BODY CONNECTOR

- (a) Install the throttle with motor body connector bracket with the nut.

Torque: 9.0 N*m (92 kgf*cm, 80 in.*lbf)

- (b) Connect the throttle with motor body connector.
(c) Connect the wire harness clamp.

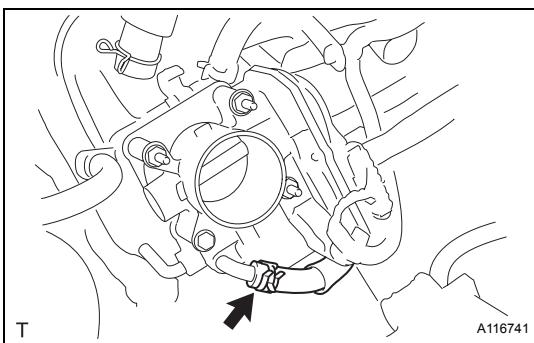

52. CONNECT WATER BY-PASS HOSE

- (a) Connect the water by-pass hose.

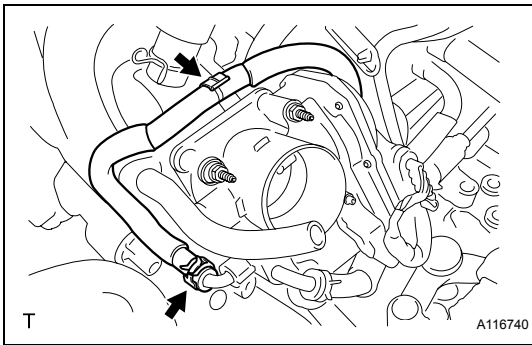
**53. CONNECT WATER BY-PASS HOSE NO. 2**

- (a) Connect water by-pass hose No. 2.

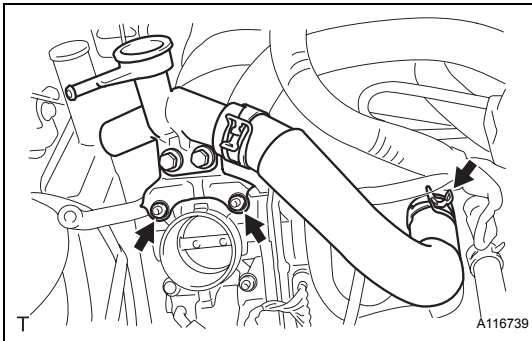
**54. INSTALL WATER FILLER SUB-ASSEMBLY**

- (a) Install the water filler sub-assembly with the 2 nuts.
Torque: 7.5 N*m (76 kgf*cm, 66 in.*lbf)
 (b) Connect radiator hose No. 1 to the cylinder head.

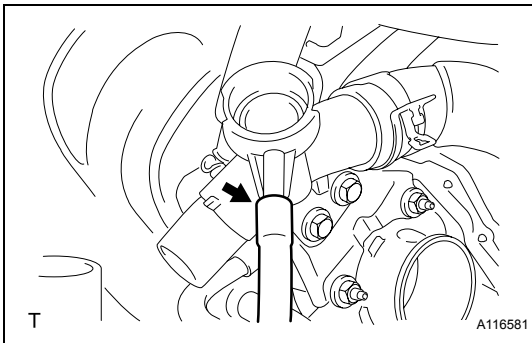
**55. CONNECT RESERVE TANK HOSE**

- (a) Connect the reserve tank hose.

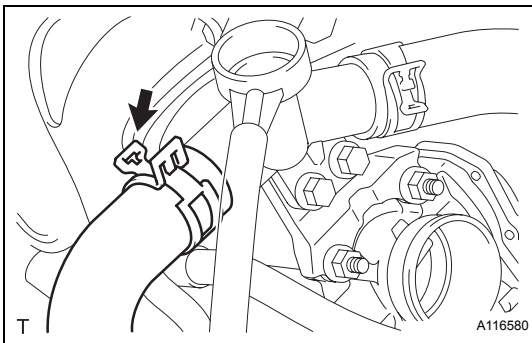
**56. CONNECT RADIATOR HOSE NO. 3**

- (a) Connect radiator hose No. 3.

57. INSTALL AIR CLEANER CAP SUB-ASSEMBLY WITH AIR CLEANER HOSE NO. 1 (See page [ES-414](#))**58. INSTALL BATTERY TRAY****59. INSTALL BATTERY****60. ADD ENGINE OIL****61. ADD ENGINE COOLANT (See page [CO-8](#))****62. CHECK ENGINE OIL LEVEL (See page [LU-1](#))****63. CHECK FOR ENGINE OIL LEAKAGE****64. CHECK FOR ENGINE COOLANT LEAKAGE (See page [CO-1](#))****65. CHECK FOR EXHAUST GAS LEAKAGE****66. CHECK FOR FUEL LEAKAGE (See page [FU-7](#))****67. INSTALL CYLINDER HEAD COVER NO. 2 (See page [IG-10](#))**

68. INSTALL ENGINE UNDER COVER RH
69. INSTALL FRONT WHEEL RH
70. INSTALL COWL TOP PANEL OUTER (for Hatchback)
(See page [EM-146](#))
71. INSTALL COWL TOP PANEL OUTER (for Sedan) (See
page [ES-434](#))
72. INSTALL COWL TO REGISTER DUCT SUB-
ASSEMBLY NO. 2 (for Hatchback) (See page [EM-147](#))
73. INSTALL FRONT AIR SHUTTER SEAL RH (for Sedan)
(See page [ES-435](#))
74. INSTALL FRONT WIPER MOTOR AND LINK (for
Hatchback) (See page [WW-21](#))
75. INSTALL FRONT WIPER MOTOR AND LINK (for
Sedan) (See page [WW-12](#))
76. INSTALL COWL TOP VENTILATOR LOUVER LH (for
Hatchback) (See page [WW-21](#))
77. INSTALL COWL TOP VENTILATOR LOUVER SUB-
ASSEMBLY (for Hatchback) (See page [WW-21](#))
78. INSTALL COWL TOP VENTILATOR LOUVER SUB-
ASSEMBLY (for Sedan) (See page [WW-12](#))
79. INSTALL COWL SIDE VENTILATOR SUB-ASSEMBLY
LH (for Sedan) (See page [WW-13](#))
80. INSTALL COWL SIDE VENTILATOR SUB-ASSEMBLY
RH (for Sedan) (See page [WW-13](#))
81. INSTALL HOOD TO COWL TOP SEAL (for
Hatchback) (See page [WW-22](#))
82. INSTALL FRONT WIPER ARM AND BLADE
ASSEMBLY LH (for Hatchback) (See page [WW-22](#))
83. INSTALL FRONT WIPER ARM AND BLADE
ASSEMBLY LH (for Sedan) (See page [WW-13](#))
84. INSTALL FRONT WIPER ARM AND BLADE
ASSEMBLY RH (for Hatchback) (See page [WW-23](#))
85. INSTALL FRONT WIPER ARM AND BLADE
ASSEMBLY RH (for Sedan) (See page [WW-14](#))
86. INSTALL FRONT WIPER ARM HEAD CAP (for
Hatchback) (See page [WW-23](#))
87. INSTALL FRONT WIPER ARM HEAD CAP (for Sedan)
(See page [WW-15](#))

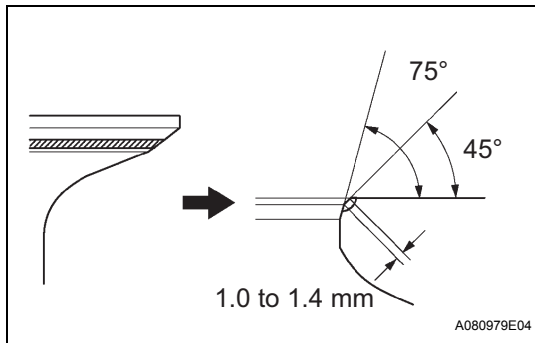
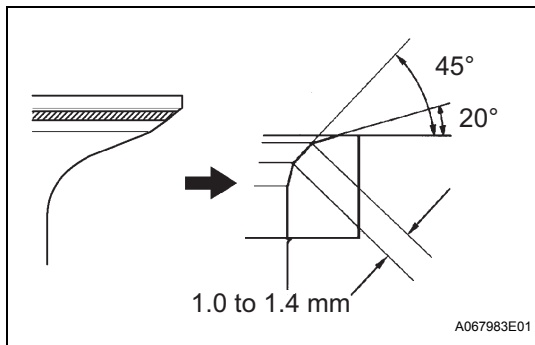

REPAIR

1. REPAIR INTAKE VALVE

- (a) Repair the intake valve seat.

NOTICE:

Releasing the seat-cutter pressure gradually helps to make the valve seat face smoother.

- (b) If the seating is too high on the valve face, use 20° and 45° cutters to correct the seat.

- (c) If the seating is too low on the valve face, use 75° and 45° cutters to correct the seat.

- (d) Hand-lap the valve and valve seat with an abrasive compound.

- (e) Recheck the valve seating position.

2. REPAIR EXHAUST VALVE

NOTICE:

Releasing the seat-cutter pressure gradually helps to make the valve seat face smoother.

- (a) If the seating is too high on the valve face, use 20° and 45° cutters to correct the seat.

- (b) If the seating is too low on the valve face, use 75° and 45° cutters to correct the seat.

- (c) Hand-lap the valve and valve seat with an abrasive compound.

- (d) Recheck the valve seating position.

ENGINE ASSEMBLY

COMPONENTS

EM

for Hatchback:

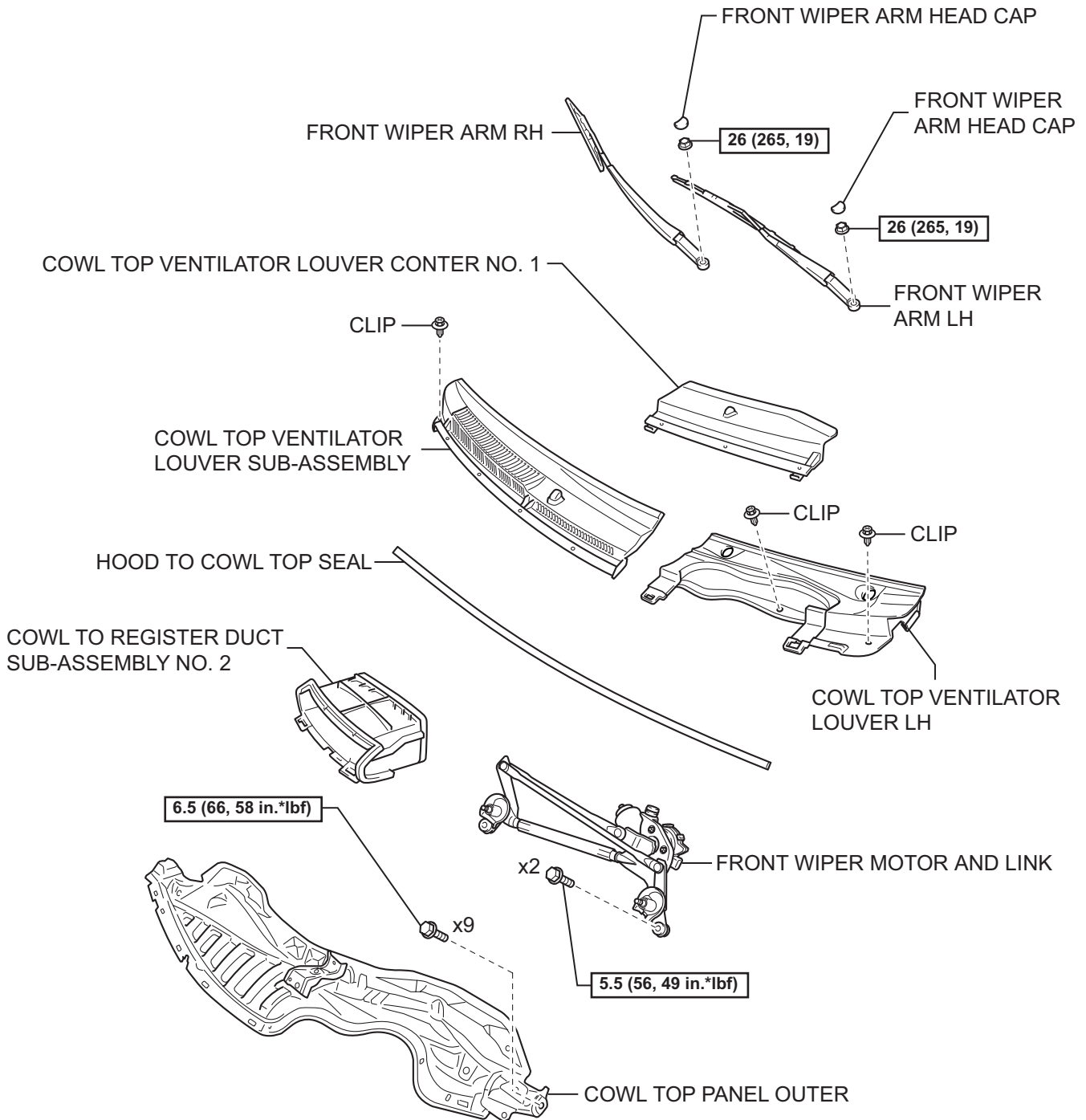

N*m (kgf*cm, ft*lbf) : Specified torque

for Sedan:

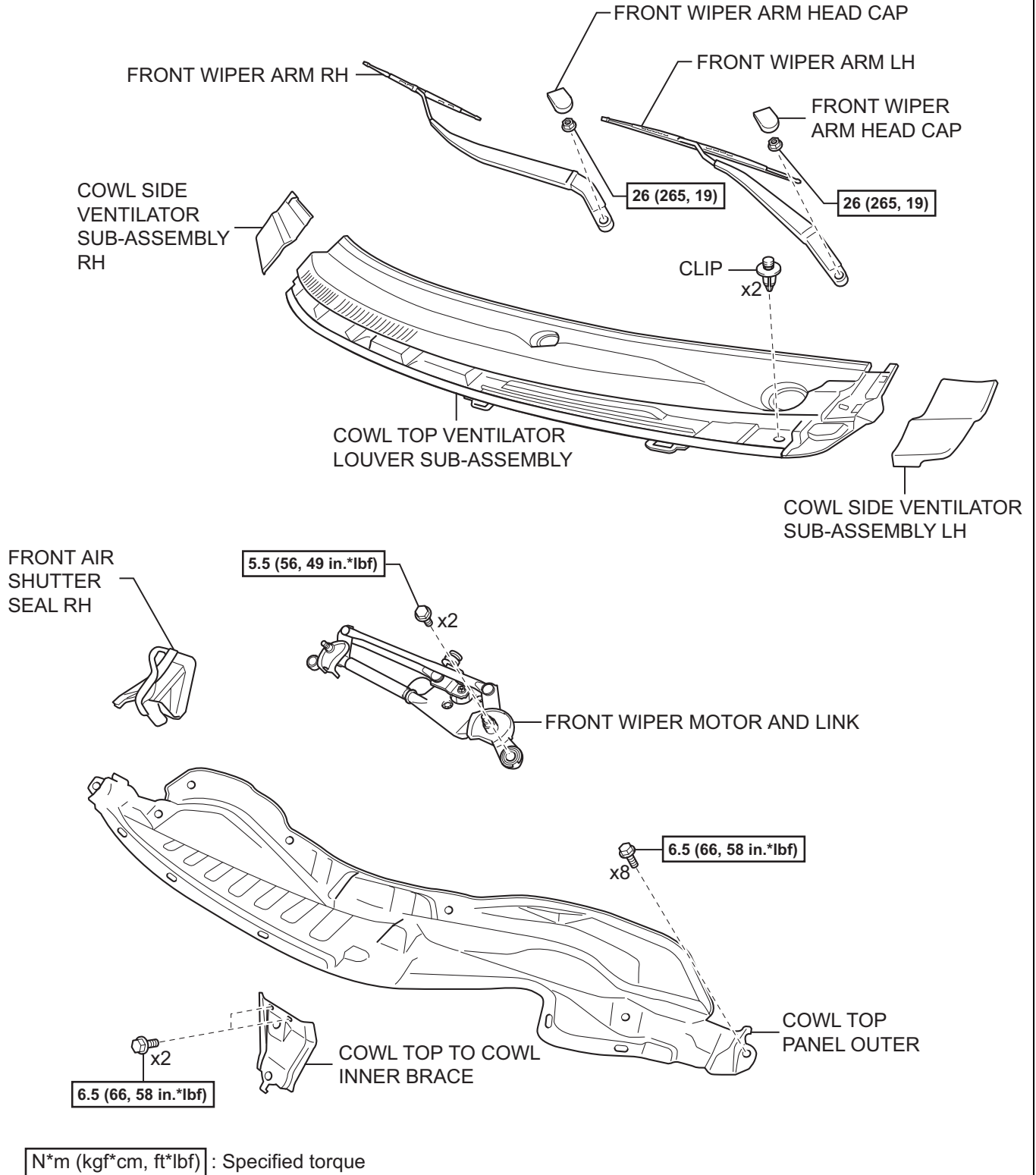

EM

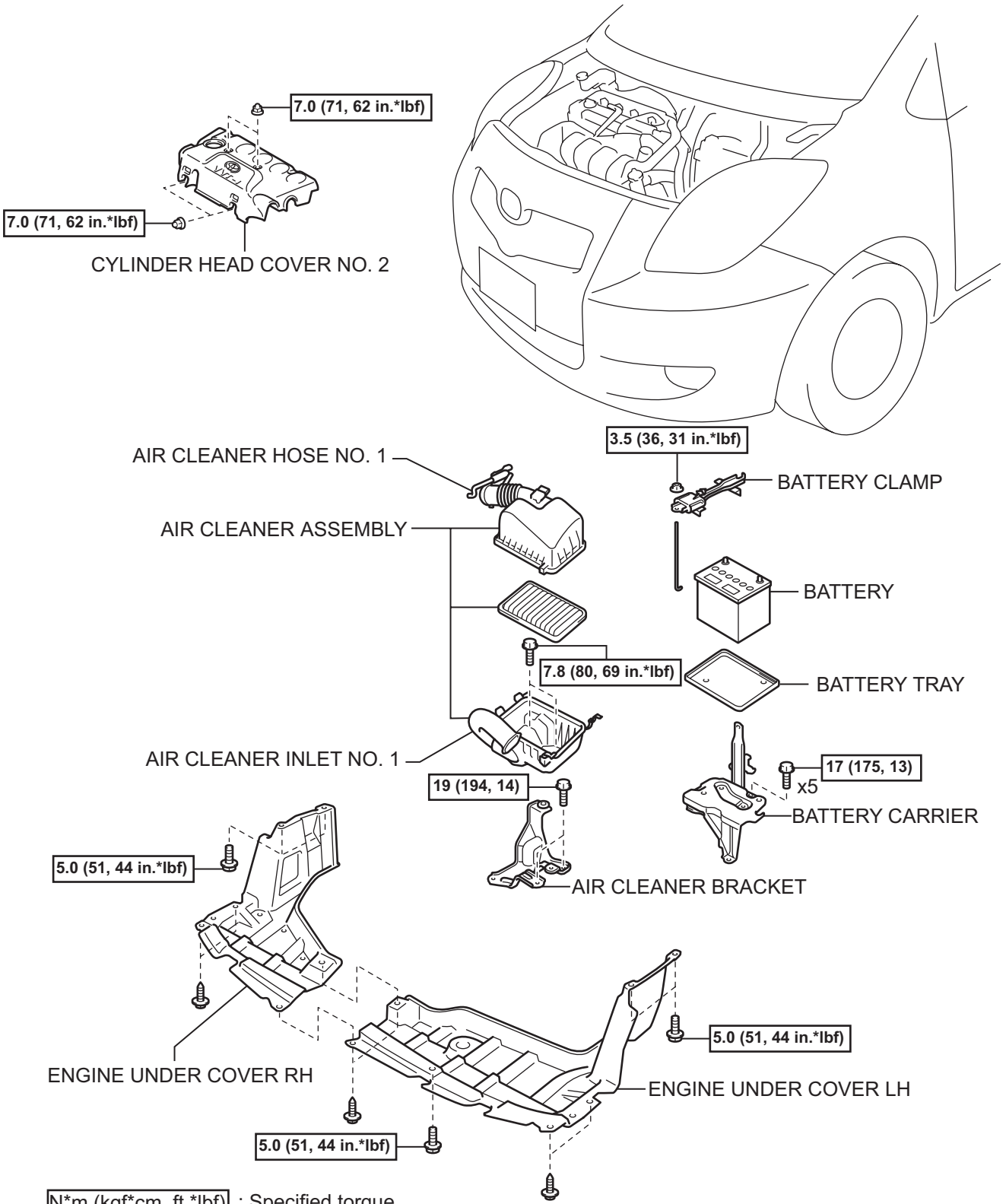

N*m (kgf*cm, ft.*lbf) : Specified torque



EM

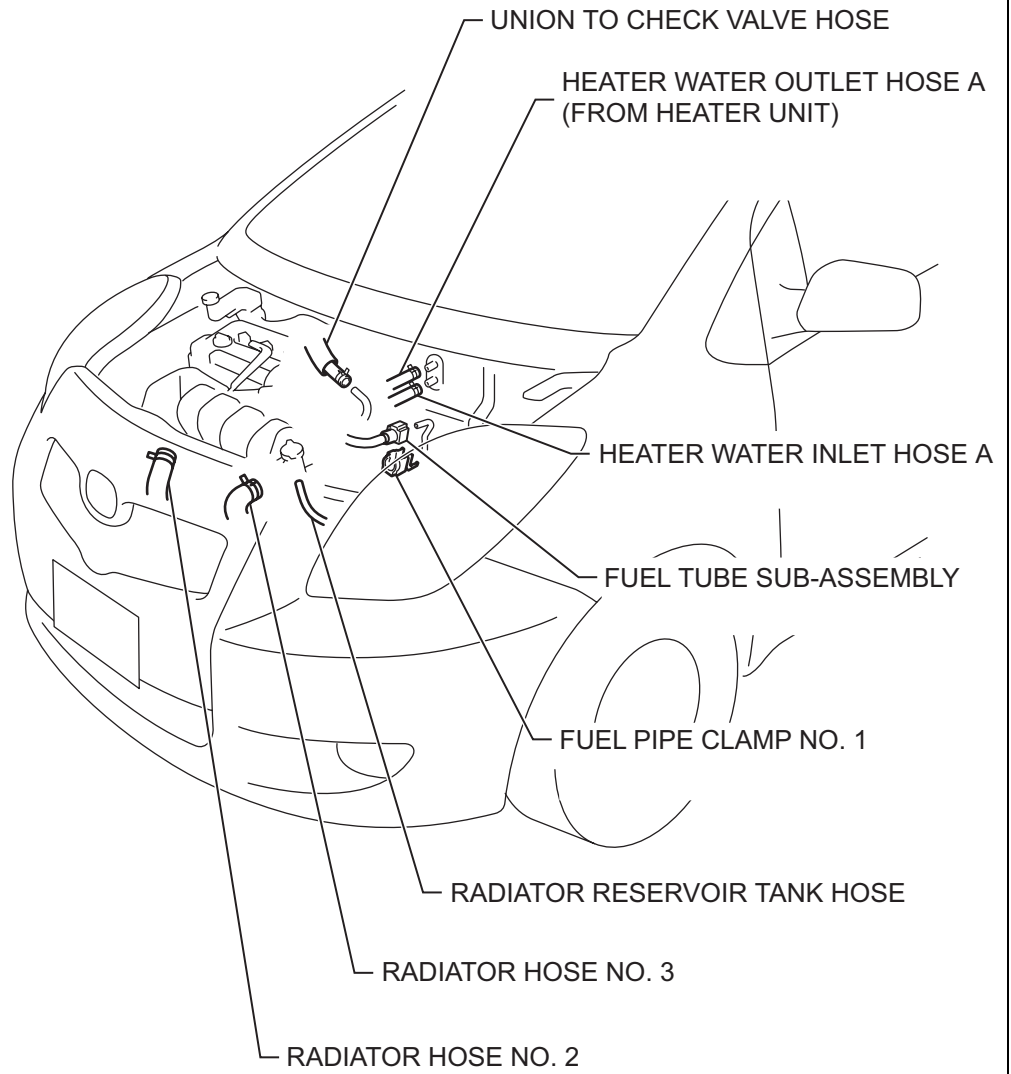

for Hatchback:

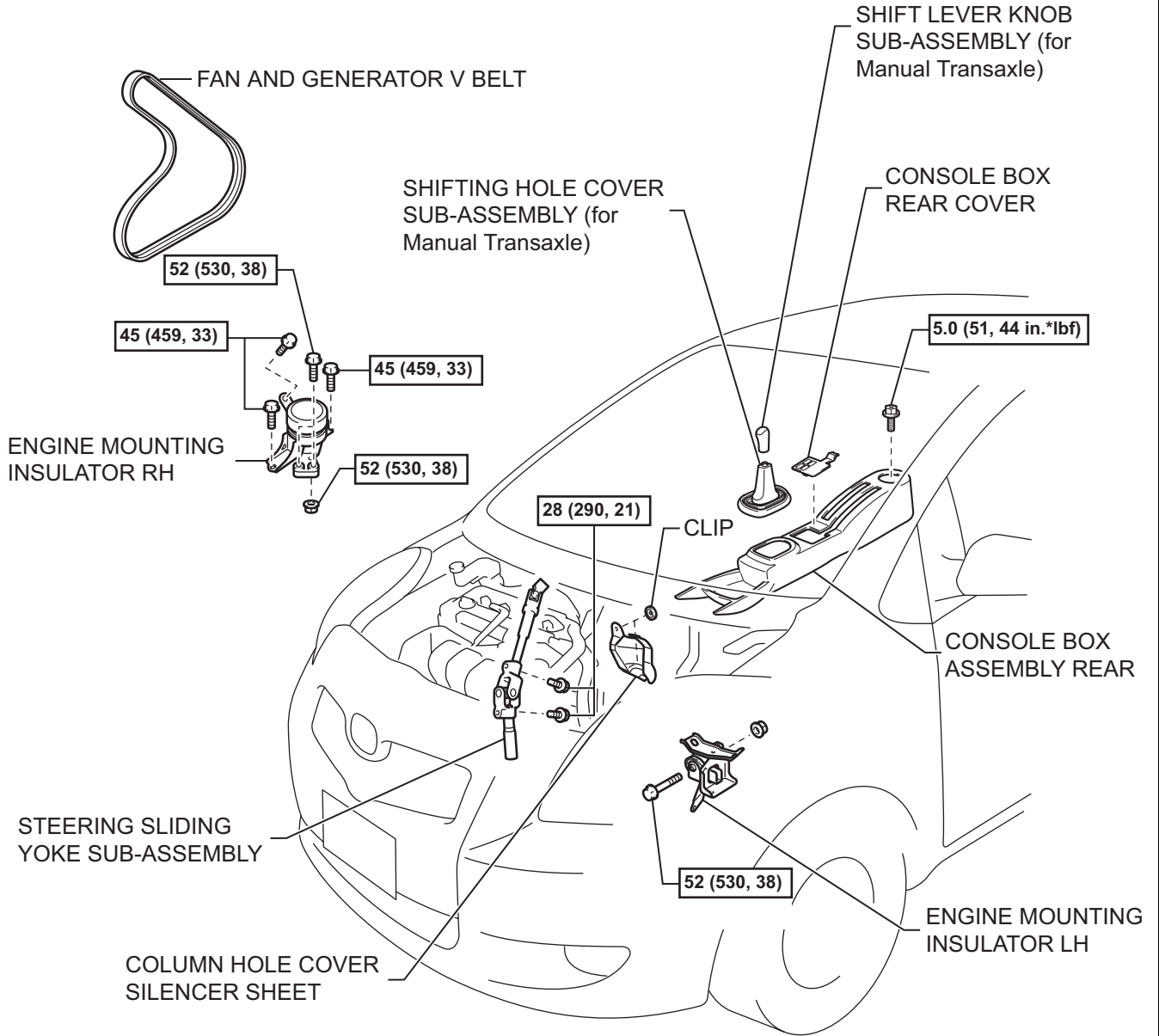

EM

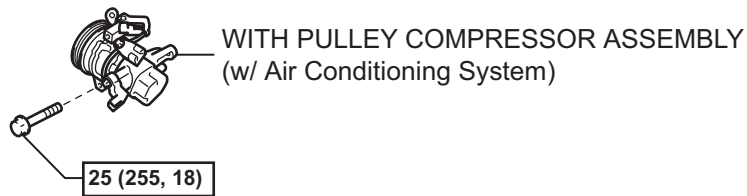

N*m (kgf*cm, ft.*lbf) : Specified torque



for Sedan:

FAN AND GENERATOR V BELT

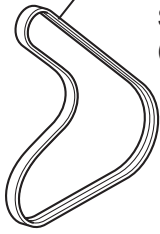

SHIFT LEVER KNOB SUB-ASSEMBLY
(for Manual Transaxle)

SHIFTING HOLE COVER SUB-ASSEMBLY

UPPER CONSOLE PANEL SUB-ASSEMBLY

CONSOLE UPPER REAR
PANEL SUB-ASSEMBLY

CONSOLE BOX
CARPET

EM

52 (530, 38)

52 (530, 38)

INSTRUMENT
PANEL FINISH
PANEL END LH

ENGINE MOUNTING
INSULATOR RH

CONSOLE BOX
ASSEMBLY REAR

STEERING SLIDING
YOKE SUB-ASSEMBLY

CLIP

INSTRUMENT PANEL
FINISH PANEL LOWER
CENTER

INSTRUMENT
PAD LOWER LH

28 (290, 21)

52 (530, 38)

COLUMN HOLE COVER
SILENCER SHEET

ENGINE MOUNTING
INSULATOR LH

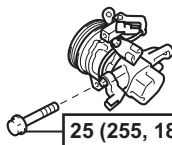

WITH PULLEY COMPRESSOR ASSEMBLY
(w/ Air Conditioning System)

25 (255, 18)

N*m (kgf*cm, ft*lbf) : Specified torque

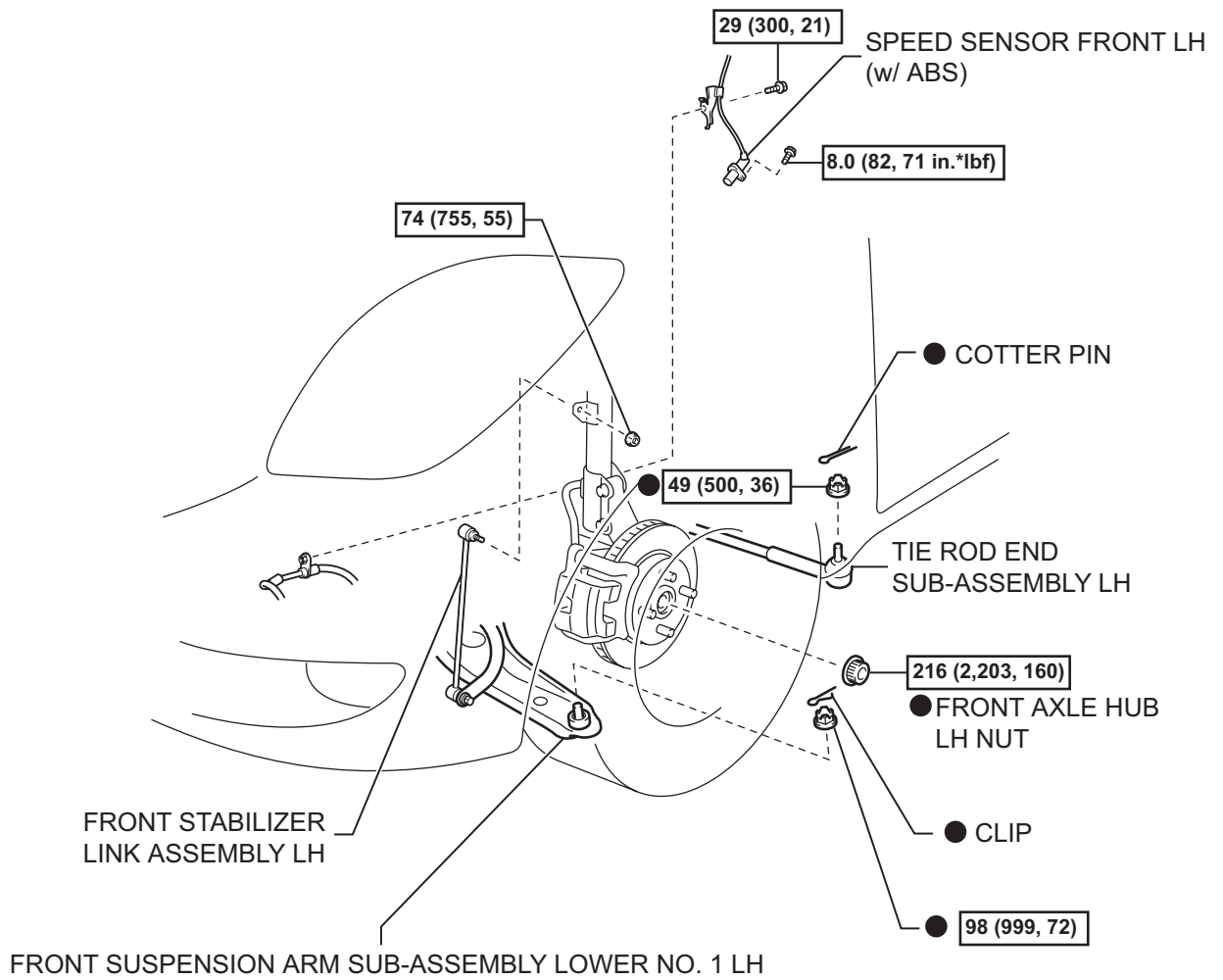

N*m (kgf*cm, ft.*lbf) : Specified torque ● Non-reusable part



EM

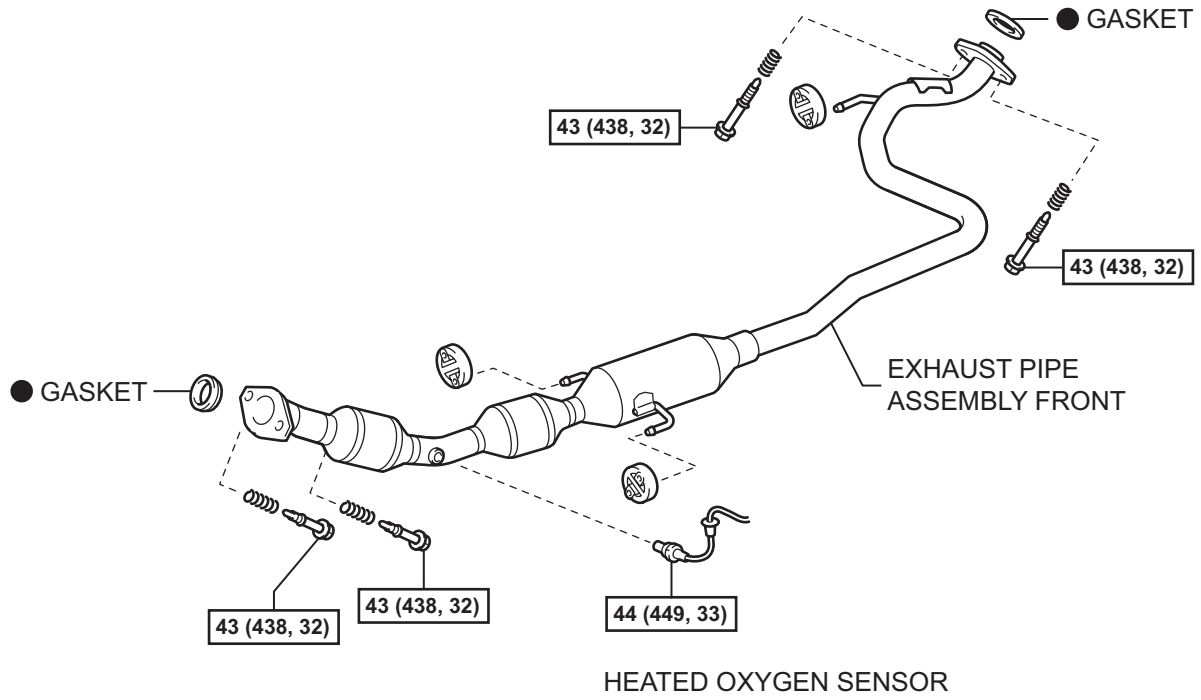

$\boxed{\text{N}^*\text{m (kgf}^*\text{cm, ft}^*\text{lbf)}}$: Specified torque

 ● Non-reusable part

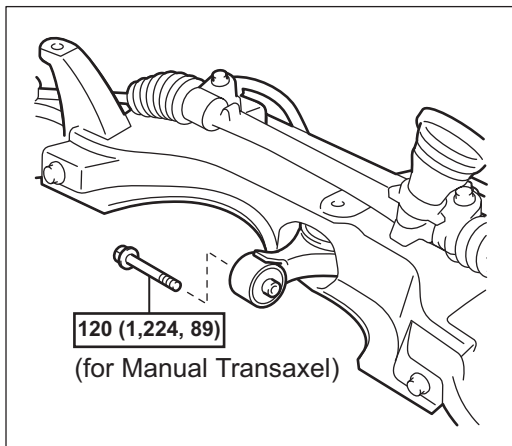
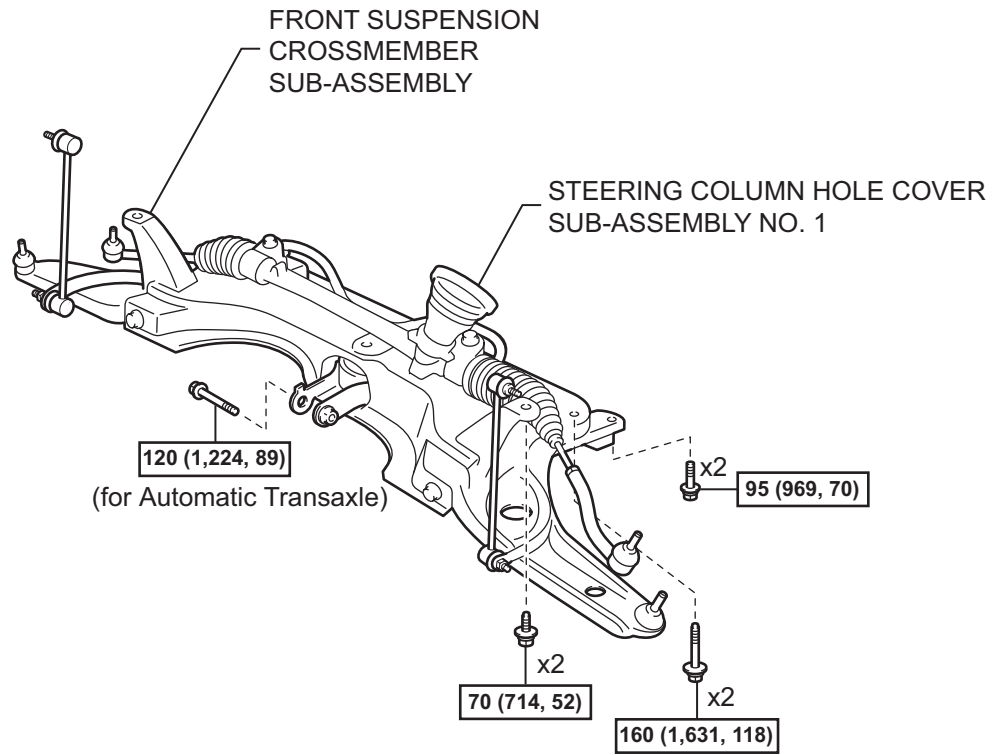

N*m (kgf*cm, ft.*lbf) : Specified torque



for Automatic Transaxle:

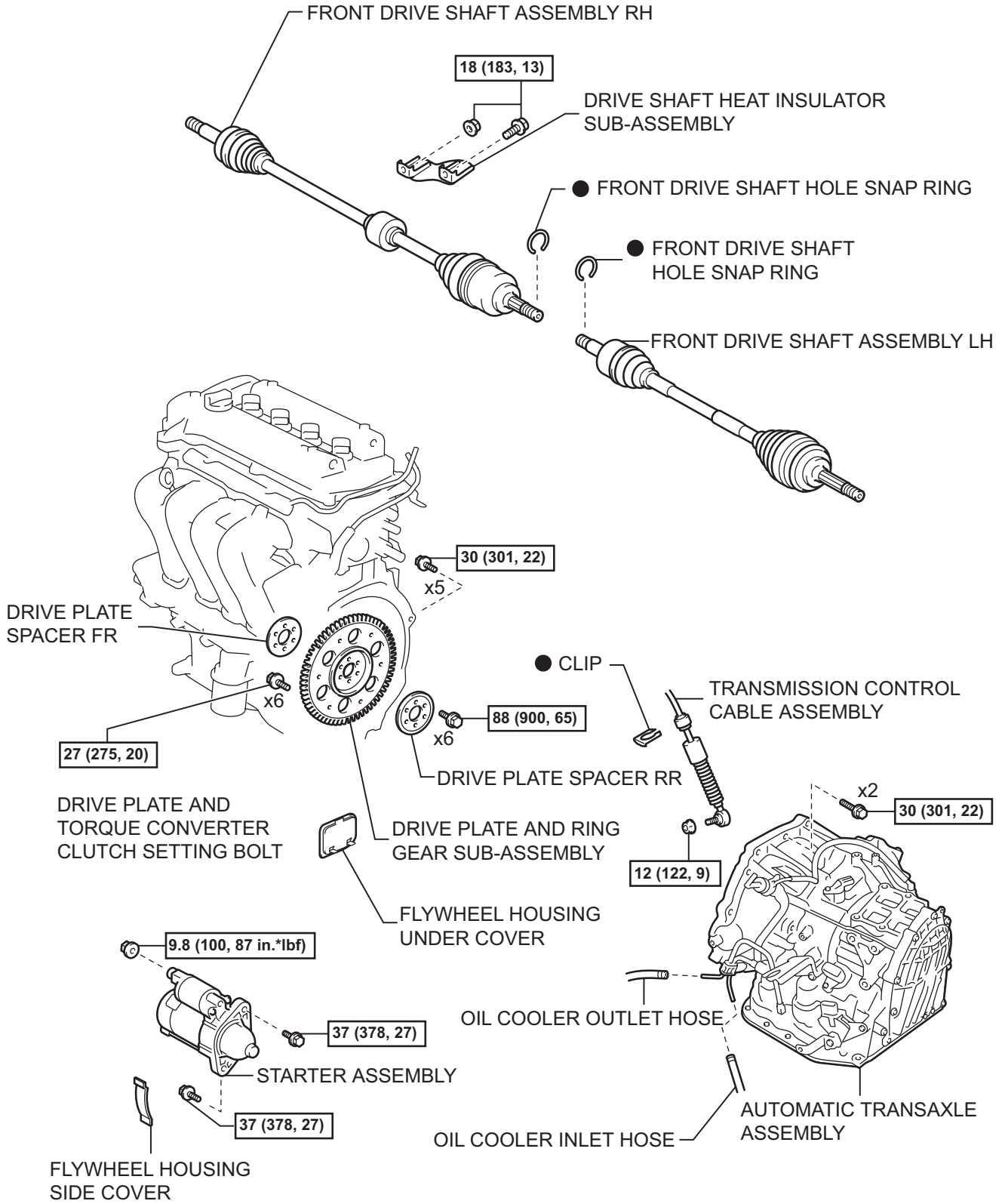

N*m (kgf*cm, ft.*lbf) : Specified torque ● Non-reusable part

EM



for Manual Transaxle:

EM

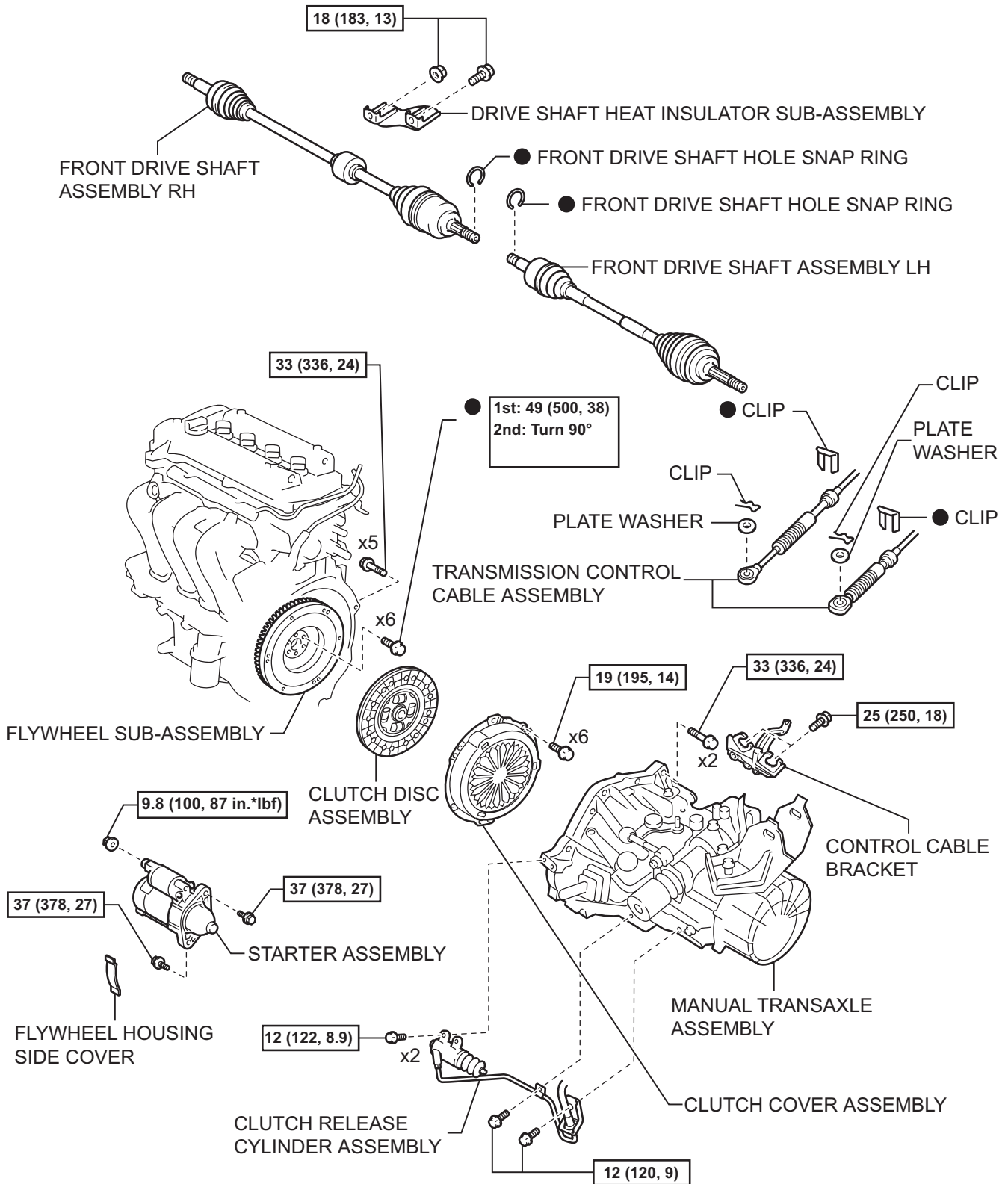

N*m (kgf*cm, ft*lbf) : Specified torque

● Non-reusable part



EM

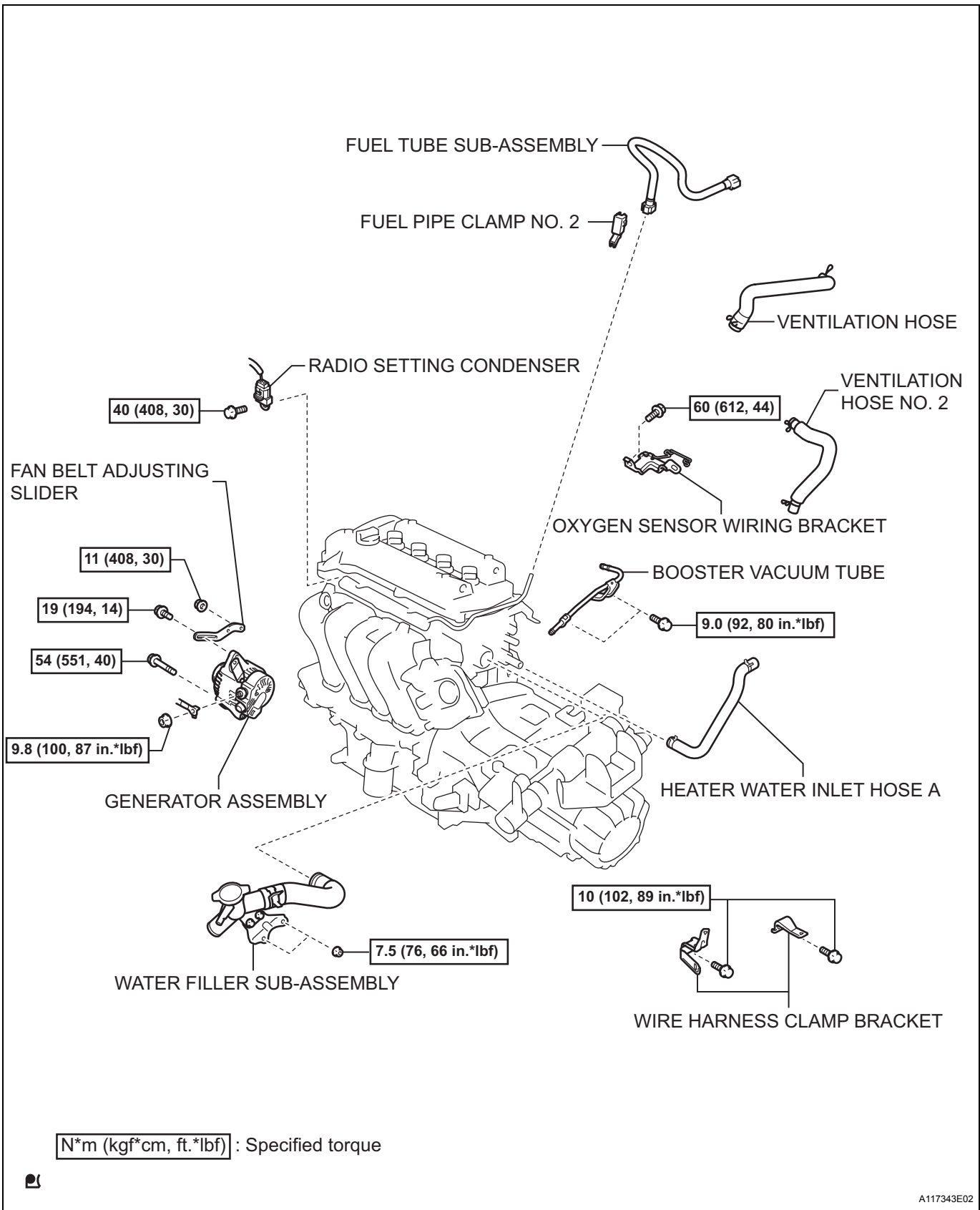

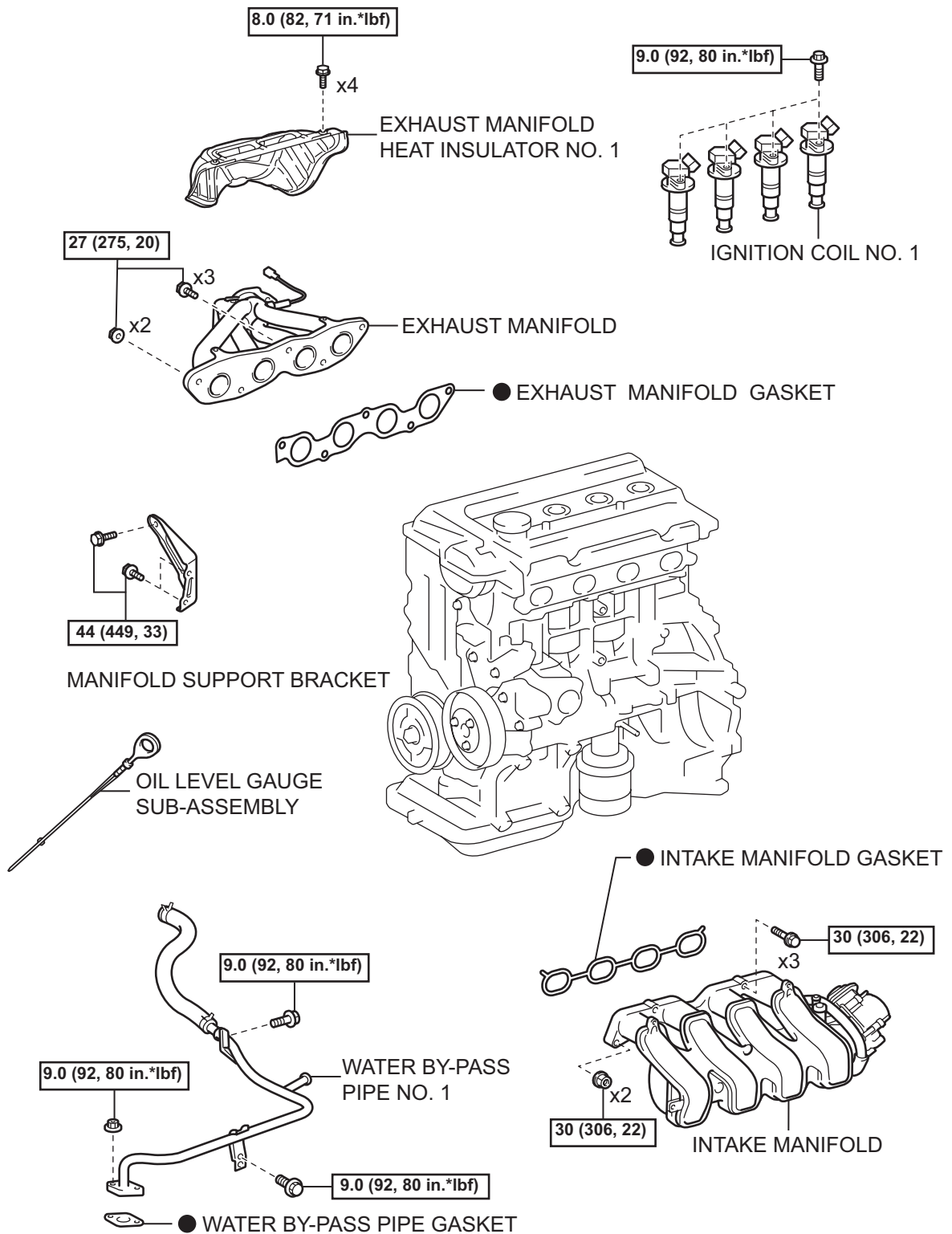

$\boxed{N^*m (kgf^*cm, ft.^*lbf)}$: Specified torque ● Non-reusable part



REMOVAL

1. **DISCHARGE FUEL SYSTEM PRESSURE**
2. **REMOVE BATTERY**
 - (a) Disconnect the cable from the battery terminal.
 - (b) Loosen the nut and remove the battery clamp.
 - (c) Remove the battery.
3. **REMOVE BATTERY TRAY**
4. **REMOVE FRONT WHEELS**
5. **REMOVE ENGINE UNDER COVER LH**
6. **REMOVE ENGINE UNDER COVER RH**
7. **DRAIN ENGINE COOLANT** (See page [CO-8](#))
8. **DRAIN AUTOMATIC TRANSAXLE FLUID** (for Automatic Transaxle) (See page [AX-158](#))
9. **DRAIN MANUAL TRANSAXLE OIL** (for Manual Transaxle) (See page [MX-26](#))
10. **REMOVE FRONT WIPER ARM HEAD CAP** (See page [WW-9](#))
11. **REMOVE FRONT WIPER ARM LH** (See page [WW-9](#))
12. **REMOVE FRONT WIPER ARM RH** (See page [WW-9](#))
13. **REMOVE HOOD TO COWL TOP SEAL** (for Hatchback) (See page [WW-18](#))
14. **REMOVE COWL TOP VENTILATOR LOUVER SUB-ASSEMBLY** (for Hatchback) (See page [WW-18](#))
15. **REMOVE COWL TOP VENTILATOR LOUVER LH** (for Hatchback) (See page [WW-18](#))
16. **REMOVE COWL SIDE VENTILATOR SUB-ASSEMBLY LH** (for Sedan) (See page [WW-10](#))
17. **REMOVE COWL SIDE VENTILATOR SUB-ASSEMBLY RH** (for Sedan) (See page [WW-10](#))
18. **REMOVE COWL TOP VENTILATOR LOUVER SUB-ASSEMBLY** (for Sedan) (See page [WW-10](#))
19. **REMOVE FRONT WIPER MOTOR AND LINK** (See page [WW-19](#))
20. **REMOVE COWL TO REGISTER DUCT SUB-ASSEMBLY NO. 2** (for Hatchback)
 - (a) Disengage the claw and remove cowl to register duct sub-assembly No. 2.

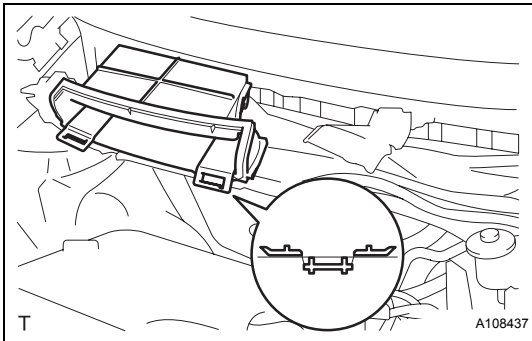

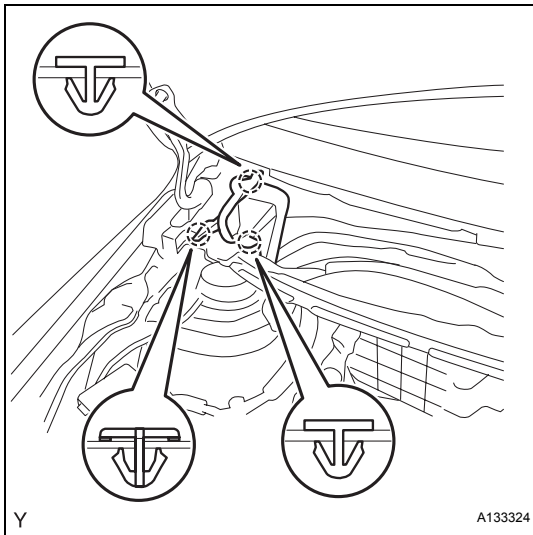

21. REMOVE FRONT AIR SHUTTER SEAL RH (for Sedan)

- (a) Disengage the 3 claws and remove the front air shutter seal RH.

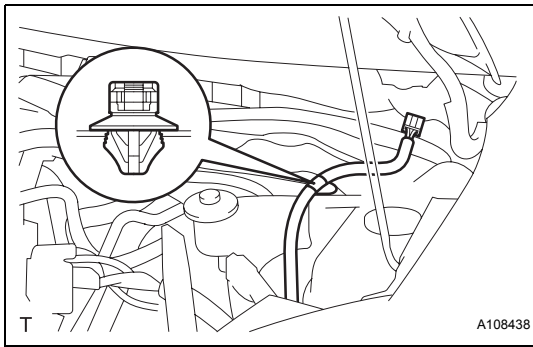

22. REMOVE COWL TOP PANEL OUTER (for Hatchback)

- (a) Disengage the wire harness clamp.



- (b) Remove the 9 bolts and remove the cowl top panel outer.

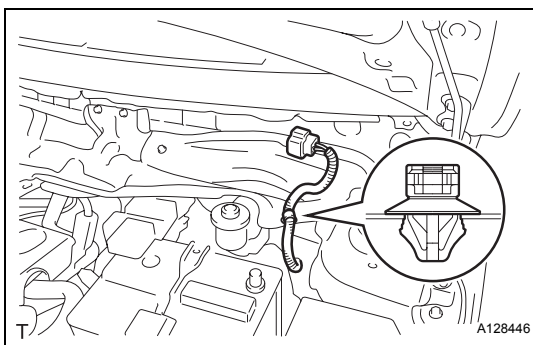

23. REMOVE COWL TOP PANEL OUTER (for Sedan)

- (a) Disengage the wire harness clamp.

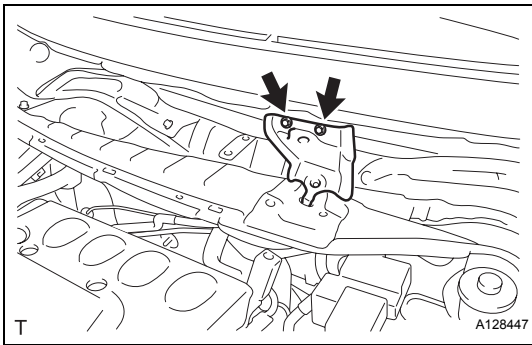

- (b) Remove the 2 bolts and remove the cowl top to cowl inner brace.

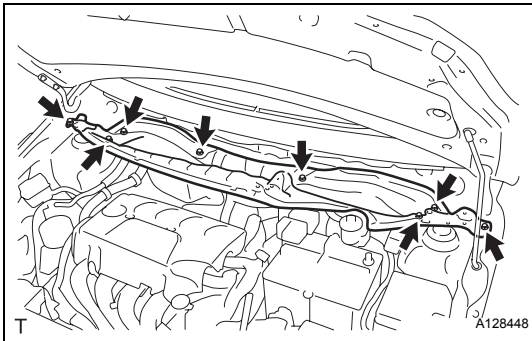

- (c) Remove the 8 bolts and remove the cowl top panel outer.

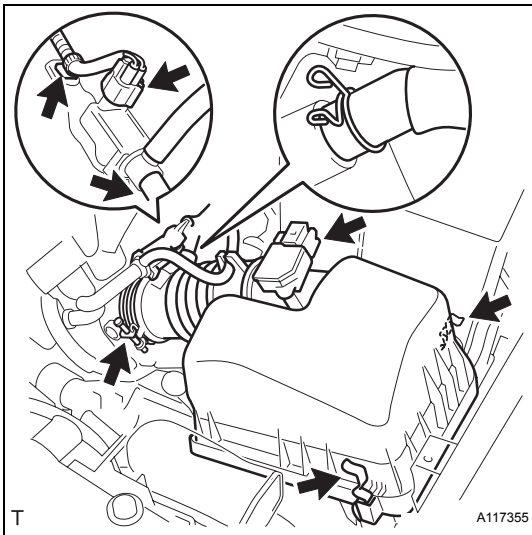

24. REMOVE AIR CLEANER ASSEMBLY

- (a) Separate the intake air flow meter connector and the wire harness clamp.
- (b) Separate the fuel vapor feed hose and fuel vapor feed hose No. 1 from the vacuum switching valve assembly.
- (c) Separate the vacuum switching valve connector and the wire harness clamp.
- (d) Separate the ventilation hose from the air cleaner hose.
- (e) Release the air cleaner cap sub-assembly with air cleaner hose No. 1.
- (f) Loosen the air cleaner hose clamp on the throttle body side and remove the air cleaner cap and the air cleaner hose.
- (g) Remove the air cleaner element.
- (h) Separate the wire harness clamp from the air cleaner case.
- (i) Remove the 2 bolts and remove the air cleaner case with air cleaner inlet No. 1.

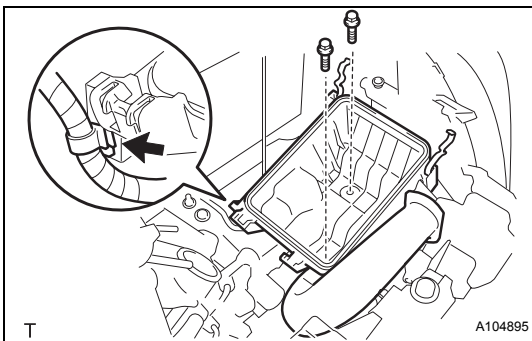

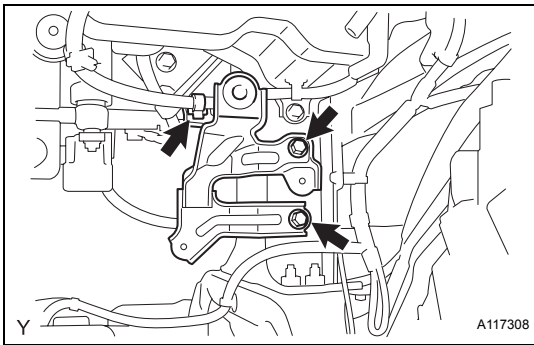
**25. REMOVE AIR CLEANER BRACKET**

- (a) Separate the wire harness clamp from the air cleaner bracket.
- (b) Remove the 2 bolts and remove the air cleaner bracket.

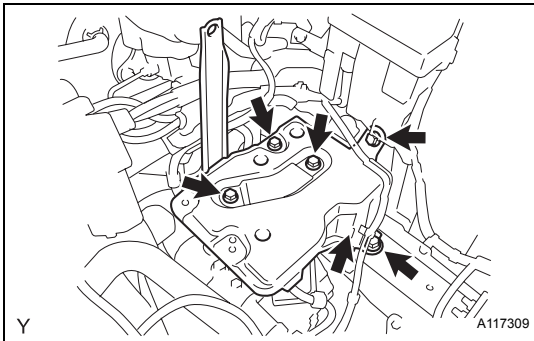
**26. REMOVE BATTERY CARRIER**

- (a) Separate the wire harness clamp from the battery carrier.
- (b) Remove the 5 bolts and remove the battery carrier.

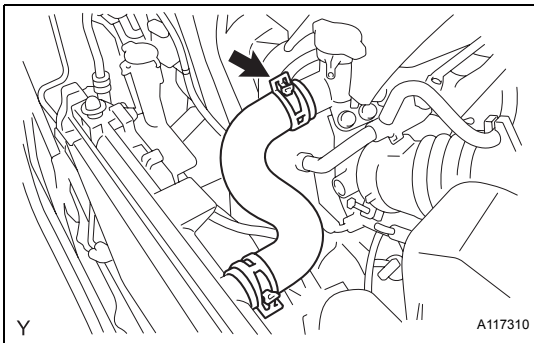
**27. DISCONNECT RADIATOR HOSE NO. 3**

- (a) Disconnect radiator hose No. 3 from the water filler.

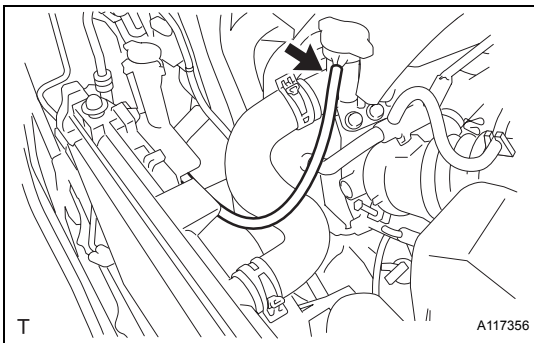
**28. DISCONNECT RADIATOR RESERVOIR TANK HOSE**

- (a) Disconnect the radiator reservoir tank hose from the water filler.

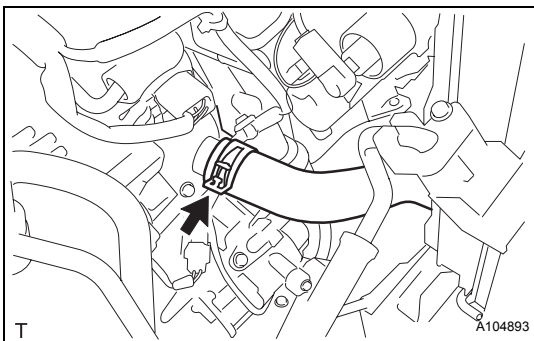
**29. DISCONNECT RADIATOR HOSE NO. 2**

- (a) Disconnect radiator hose No. 2 from the water inlet.

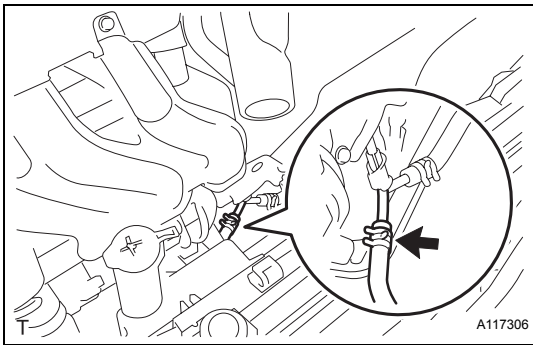

30. DISCONNECT OIL COOLER OUTLET HOSE (for Automatic Transaxle)

- (a) Loosen the clip and disconnect the oil cooler outlet hose.

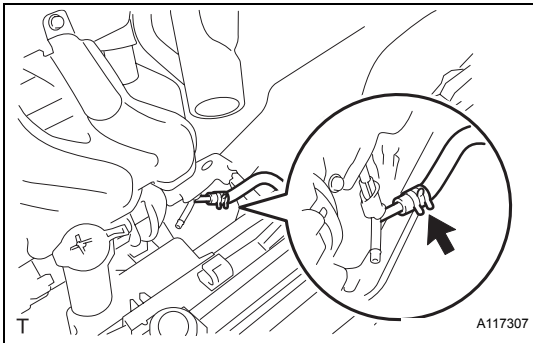

31. DISCONNECT OIL COOLER INLET HOSE (for Automatic Transaxle)

- (a) Loosen the clip and disconnect the oil cooler inlet hose.

32. REMOVE CYLINDER HEAD COVER NO. 2 (See page IG-9)

33. SEPARATE TRANSMISSION CONTROL CABLE ASSEMBLY (for Automatic Transaxle) (See page AX-106)

34. SEPARATE TRANSMISSION CONTROL CABLE ASSEMBLY (for Manual Transaxle) (See page MX-27)

35. DISCONNECT UNION TO CHECK VALVE HOSE

- (a) Disconnect the union to check valve hose from the booster vacuum tube.

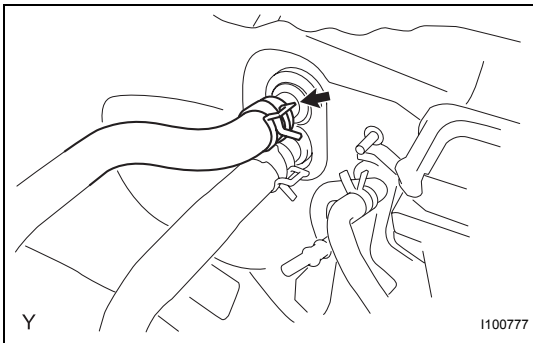

36. DISCONNECT HEATER WATER OUTLET HOSE A (FROM HEATER UNIT)

- (a) Disconnect heater water outlet hose A from the heater unit.

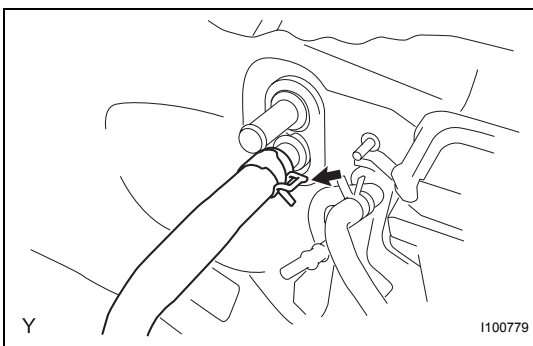

37. DISCONNECT HEATER WATER INLET HOSE A

- (a) Disconnect heater water inlet hose A from the heater unit.

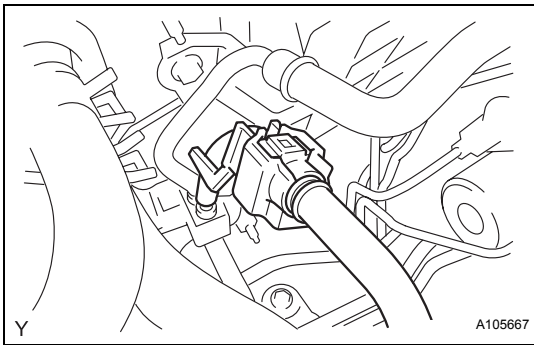
**38. DISCONNECT FUEL TUBE SUB-ASSEMBLY**

- (a) Remove fuel pipe clamp No. 1.

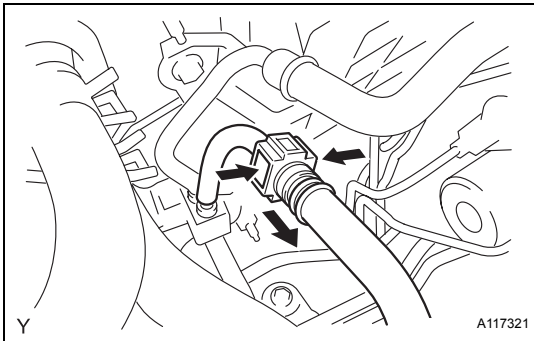

- (b) Pinch the retainer as illustrated, then pull the fuel tube connector out of the pipe.

NOTICE:

- Remove any dirt and foreign matter from the fuel tube connector before performing this work.
- Do not allow any scratches or foreign matter on the parts when disconnecting, as the fuel tube connector has the O-rings that seal the pipe.
- Perform this work by hand. Do not use any tools.
- Do not forcibly bend, twist or turn the nylon tube.
- Protect the disconnected parts by covering them with vinyl bags after disconnecting the fuel tube.
- If the fuel tube connector and pipe are stuck, push and pull to release them.

39. REMOVE FAN AND GENERATOR V BELT (See page [EM-7](#))**40. SEPARATE WITH PULLEY COMPRESSOR ASSEMBLY (w/ Air Conditioning System)**

- (a) Disconnect the connector.
 (b) Remove the 4 bolts and separate the with pulley compressor assembly.

HINT:

Remove the compressor assembly together with the low and high pressure hoses, then suspend them from the body with a piece of rope.

41. SEPARATE CLUTCH RELEASE CYLINDER ASSEMBLY (for Manual Transaxle) (See page [MX-27](#))

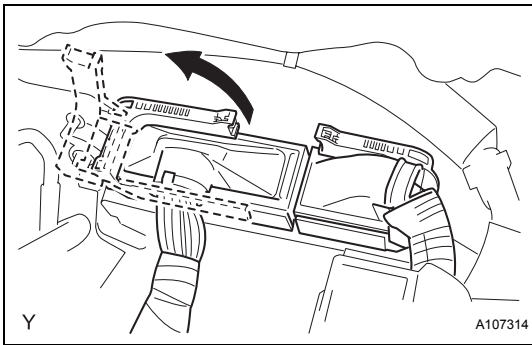
**42. DISCONNECT ENGINE WIRE**

- (a) Pull up the lever and disconnect the connector of the engine control computer.

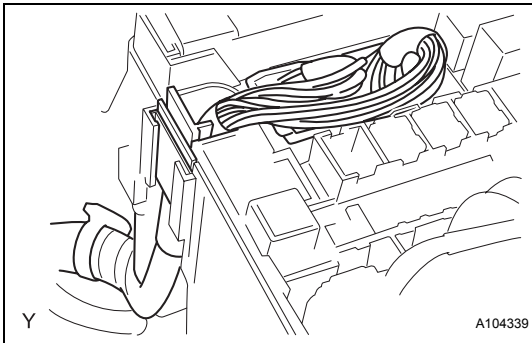

- (b) Remove the 2 connectors and the clamp from the engine room junction block and disconnect the wire harness.

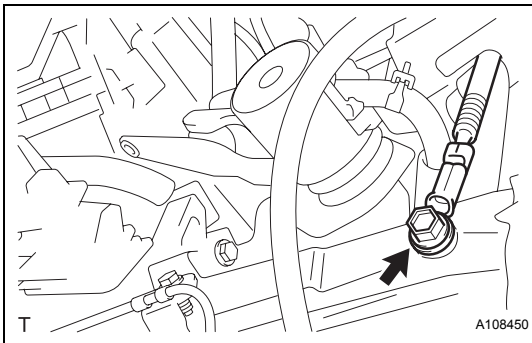

- (c) Remove the bolt and separate the earth wire of the engine room wire harness.
- (d) Disconnect all the wire harnesses and connectors. Make sure that no wire harness is connected between the body and engine.

43. REMOVE COLUMN HOLE COVER SILENCER SHEET (See page PS-74)**44. SEPARATE STEERING SLIDING YOKE SUB-ASSEMBLY (See page PS-74)****45. REMOVE STEERING COLUMN HOLE COVER SUB-ASSEMBLY NO. 1 (See page PS-75)****46. REMOVE SHIFT LEVER KNOB SUB-ASSEMBLY (for Manual Transaxle)****47. REMOVE SHIFTING HOLE COVER SUB-ASSEMBLY (for Manual Transaxle) (See page PB-6)****48. REMOVE CONSOLE BOX REAR COVER (for Hatchback) (See page PB-6)****49. REMOVE INSTRUMENT PANEL FINISH PANEL LOWER CENTER (for Sedan) (See page ME-138)****50. REMOVE INSTRUMENT PANEL FINISH PANEL END LH (for Sedan) (See page ME-138)****51. REMOVE INSTRUMENT PAD LOWER LH (for Sedan) (See page IP-44)****52. REMOVE UPPER CONSOLE PANEL SUB-ASSEMBLY (for Sedan) (See page IP-84)****53. REMOVE CONSOLE UPPER REAR PANEL SUB-ASSEMBLY (for Sedan) (See page IP-84)**

54. REMOVE CONSOLE BOX CARPET (for Sedan) (See page [PB-7](#))
55. REMOVE REAR CONSOLE BOX ASSEMBLY (See page [PB-8](#))
56. REMOVE HEATED OXYGEN SENSOR (See page [EC-22](#))
57. REMOVE EXHAUST PIPE ASSEMBLY FRONT (See page [EX-5](#))
58. REMOVE FRONT AXLE HUB LH NUT (See page [DS-3](#))
59. REMOVE FRONT AXLE HUB RH NUT (See page [AX-159](#))
60. SEPARATE SPEED SENSOR FRONT LH (w/ ABS) (See page [DS-3](#))
61. SEPARATE SPEED SENSOR FRONT RH (w/ ABS) (See page [AX-159](#))
62. SEPARATE TIE ROD END SUB-ASSEMBLY LH (See page [DS-3](#))
63. SEPARATE TIE ROD END SUB-ASSEMBLY RH (See page [AX-160](#))
64. SEPARATE FRONT STABILIZER LINK ASSEMBLY LH (See page [DS-4](#))
65. SEPARATE FRONT STABILIZER LINK ASSEMBLY RH (See page [AX-160](#))
66. SEPARATE FRONT SUSPENSION ARM SUB-ASSEMBLY LOWER NO. 1 LH (See page [DS-4](#))
67. SEPARATE FRONT SUSPENSION ARM SUB-ASSEMBLY LOWER NO. 1 RH (See page [AX-160](#))
68. SEPARATE FRONT AXLE ASSEMBLY LH (See page [DS-4](#))
69. SEPARATE FRONT AXLE ASSEMBLY RH (See page [MX-29](#))
70. REMOVE FRONT DRIVE SHAFT ASSEMBLY LH (See page [DS-5](#))
71. REMOVE FRONT DRIVE SHAFT ASSEMBLY RH (See page [DS-5](#))
72. REMOVE FLYWHEEL HOUSING UNDER COVER (for Automatic Transaxle)

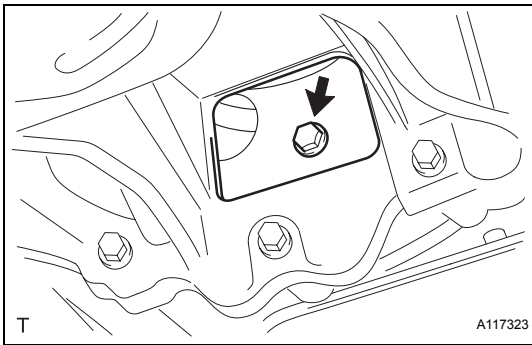

73. REMOVE DRIVE PLATE AND TORQUE CONVERTER CLUTCH SETTING BOLT (for Automatic Transaxle)

- (a) Remove the 6 torque converter set bolts.

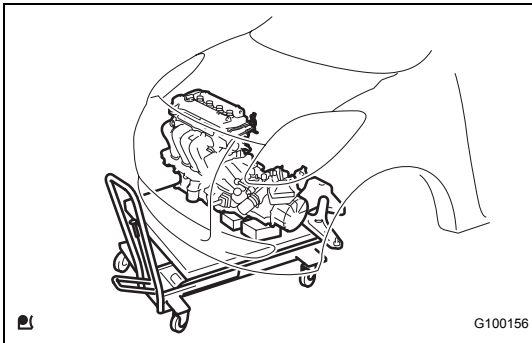

74. REMOVE ENGINE ASSEMBLY WITH TRANSAXLE

- (a) Set the engine lifter.

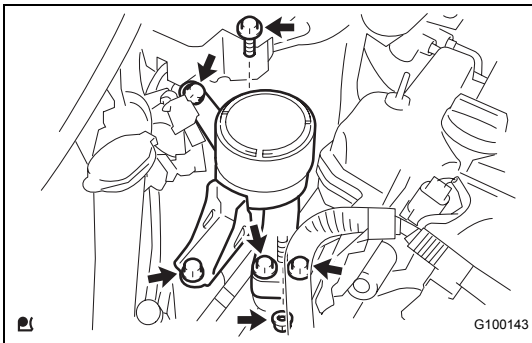

- (b) Remove the 5 bolts and the nut and remove the engine mounting insulator RH.

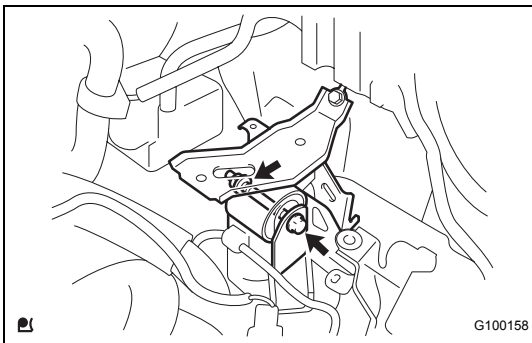

- (c) Remove the through bolt and the nut and separate the engine mounting insulator LH.

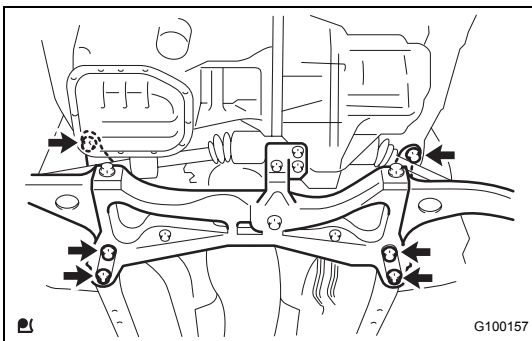

- (d) Remove the 6 bolts, and remove the engine assembly with transaxle and the front suspension crossmember from the vehicle.

75. REMOVE FRONT SUSPENSION CROSSMEMBER SUB-ASSEMBLY

- (a) Remove the bolt and remove the radio setting condenser.
- (b) Remove the bolt and remove the oxygen sensor wiring bracket.

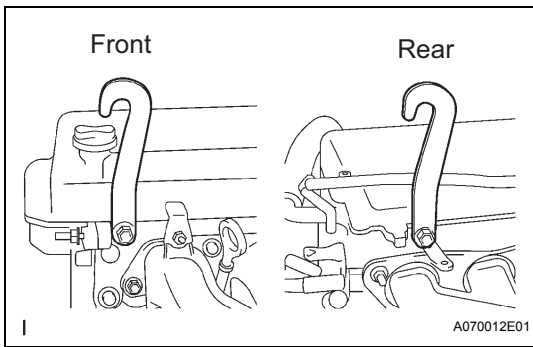

- (c) Install the engine hangers with the bolts, as shown in the illustration.

Torque: 40 N*m (408 kgf*cm, 30 ft.*lbf)

Part No.:

12281-21010 for engine hanger

91642-81025 for bolt

- (d) Using an engine sling device and a chain block, suspend the engine assembly with transaxle and front suspension crossmember.
- (e) Remove the through bolt from the engine moving control rod and remove the front suspension crossmember.

76. REMOVE VENTILATION HOSE

- (a) Loosen the 2 clips and remove the ventilation hose.

77. REMOVE VENTILATION HOSE NO. 2

- (a) Loosen the clips and remove ventilation hose No. 2.

78. REMOVE FUEL TUBE SUB-ASSEMBLY

- (a) Disengage the claw and remove fuel pipe clamp No. 2.

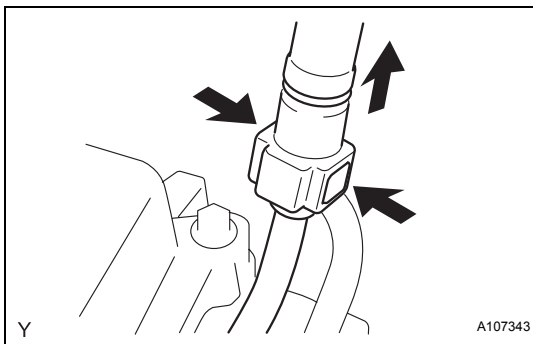
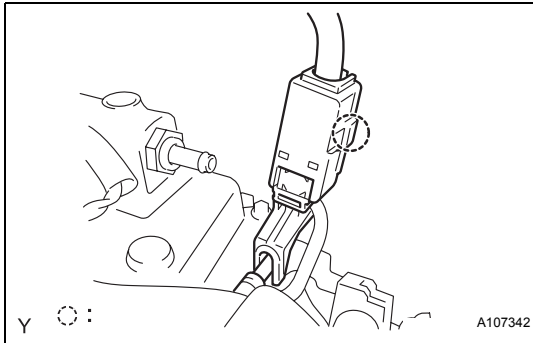

- (b) Pinch the fuel tube connector retainer from both sides, disconnect the fuel tube connector and separate the fuel tube from the pipe.

NOTICE:

- Remove any dirt and foreign matter from the fuel tube connector before performing this work.
- Do not allow any scratches or foreign matter on the parts when disconnecting, as the fuel tube connector has the O-rings that seal the pipe.
- Perform this work by hand. Do not use any tools.
- Do not forcibly bend, twist or turn the nylon tube.
- Protect the disconnected parts by covering them with vinyl bags after disconnecting the fuel tube.
- If the fuel tube connector and pipe are stuck, push and pull to release them.

79. REMOVE WATER FILLER SUB-ASSEMBLY

- (a) Disconnect radiator hose No. 1 from the cylinder head.
- (b) Remove the 2 nuts and remove the water filler sub-assembly.

EM

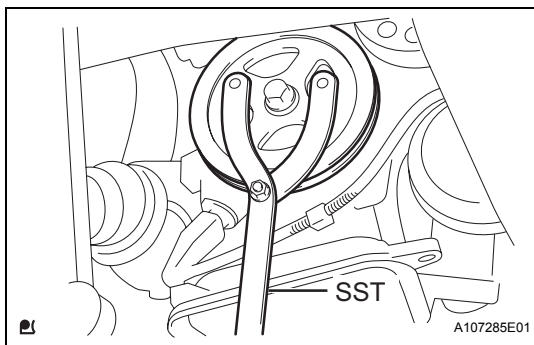
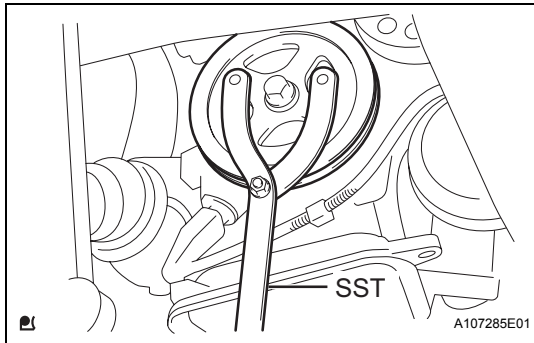
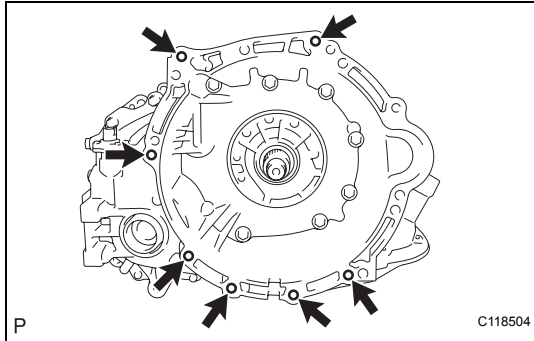

80. **REMOVE HEATER WATER INLET HOSE A**
 - (a) Disconnect heater water inlet hose A from the cylinder head.
81. **REMOVE FLYWHEEL HOUSING SIDE COVER** (See page [ST-9](#))
82. **REMOVE STARTER ASSEMBLY** (See page [ST-9](#))
83. **REMOVE AUTOMATIC TRANSAXLE ASSEMBLY** (for Automatic Transaxle)
 - (a) Remove the 7 bolts and remove the automatic transaxle with torque converter.
84. **REMOVE DRIVE PLATE AND RING GEAR SUB-ASSEMBLY** (for Automatic Transaxle)
 - (a) Hold the crankshaft with SST.
SST 09960-10010 (09962-01000, 09963-01000)
 - (b) Remove the 6 bolts, drive plate spacer FR, drive plate and ring gear sub-assembly and drive plate spacer RR.
85. **REMOVE CONTROL CABLE BRACKET** (for Manual Transaxle) (See page [MX-28](#))
86. **REMOVE MANUAL TRANSAXLE ASSEMBLY** (for Manual Transaxle) (See page [MX-30](#))
87. **REMOVE CLUTCH COVER ASSEMBLY** (for Manual Transaxle) (See page [CL-15](#))
88. **REMOVE CLUTCH DISC ASSEMBLY** (for Manual Transaxle)
89. **REMOVE FLYWHEEL SUB-ASSEMBLY** (for Manual Transaxle)
 - (a) Hold the crankshaft with SST.
SST 09960-10010 (09962-01000, 09963-01000)
 - (b) Remove the 6 bolts and flywheel.
90. **REMOVE OIL LEVEL GAUGE SUB-ASSEMBLY**
91. **REMOVE IGNITION COIL NO. 1**
 - (a) Disconnect the connectors of the ignition coils.
 - (b) Remove the bolt and remove all the ignition coils.
92. **REMOVE GENERATOR ASSEMBLY** (See page [CH-10](#))

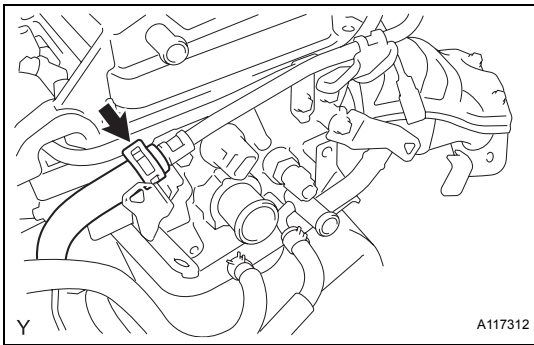
**93. REMOVE INTAKE MANIFOLD**

- (a) Disconnect the union to connector tube hose from the booster vacuum tube.
- (b) Disconnect the engine wire from the intake manifold.

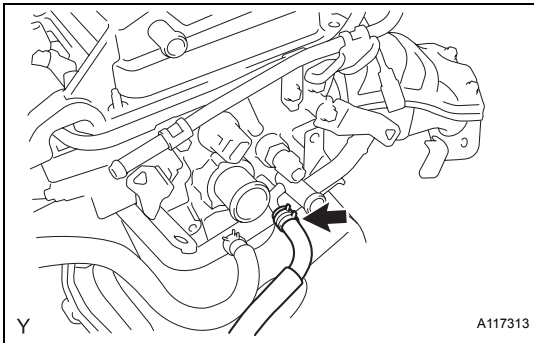

- (c) Disconnect the water by-pass hose from the cylinder head.

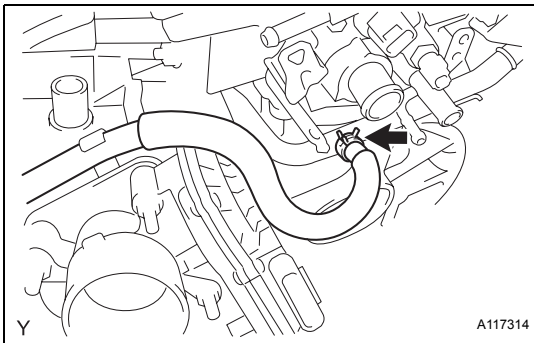

- (d) Disconnect the water by-pass hose from water bypass pipe No. 1.
- (e) Disconnect the throttle with motor body assembly connector.

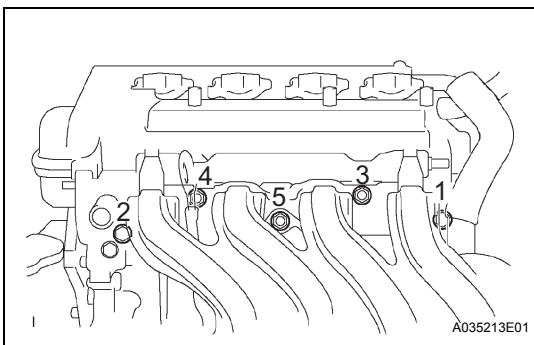

- (f) Remove the 3 bolts and 2 nuts in the order shown in the illustration and remove the intake manifold.
- (g) Remove the gasket from the intake manifold.

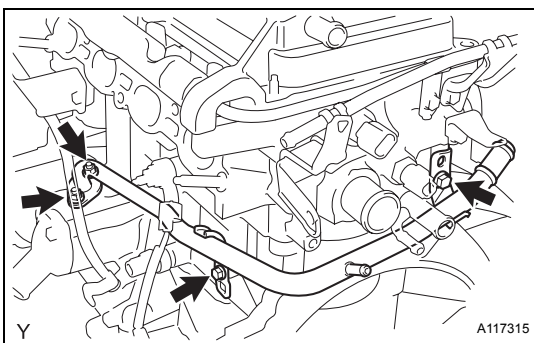
**94. REMOVE WATER BY-PASS PIPE NO. 1**

- (a) Remove the 2 bolts and 2 nuts and remove water by-pass pipe No. 1.

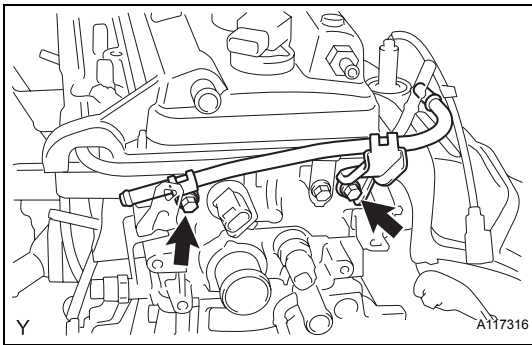
**95. REMOVE BOOSTER VACUUM TUBE**

- (a) Remove the 2 bolts and remove the booster vacuum tube.

96. REMOVE ENGINE WIRE

- (a) Disconnect all the sensor connectors and wire harness clamps from the engine assembly and remove the engine wire harness.

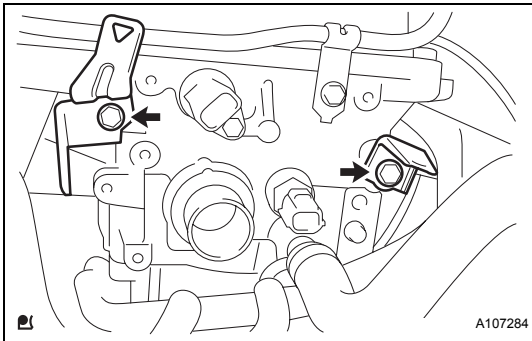
**97. REMOVE WIRE HARNESS CLAMP BRACKET**

- (a) Remove the 2 bolts and remove the 2 wire harness clamp brackets.

98. REMOVE EXHAUST MANIFOLD HEAT INSULATOR NO. 1

- (a) Remove the 4 bolts and remove the exhaust manifold heat insulator.

99. REMOVE MANIFOLD SUPPORT BRACKET

- (a) Remove the 3 bolts and remove the manifold support bracket.

100. REMOVE EXHAUST MANIFOLD

- (a) Remove the 3 bolts and 2 nuts and remove the exhaust manifold.

101. REMOVE DRIVE SHAFT HEAT INSULATOR SUB-ASSEMBLY

- (a) Remove the bolt and nut and remove the drive shaft heat insulator.

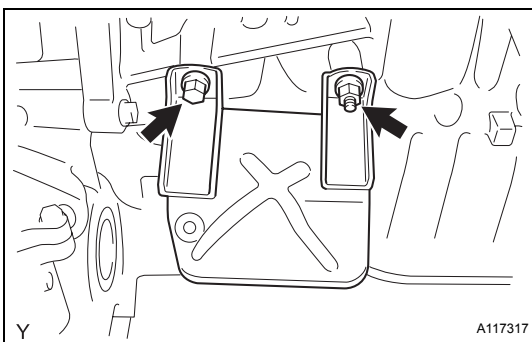
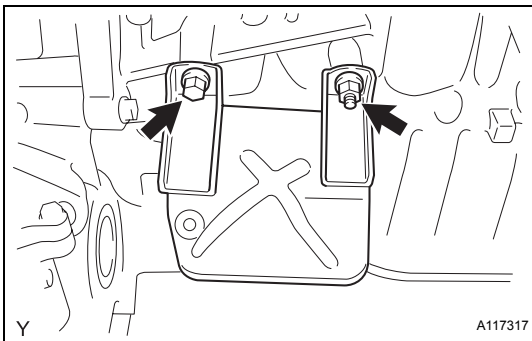
**INSTALLATION****1. INSTALL DRIVE SHAFT HEAT INSULATOR SUB-ASSEMBLY**

- (a) Install the drive shaft heat insulator sub-assembly with the bolt and nut.

Torque: 18 N*m (183 kgf*cm, 13 ft.*lbf)

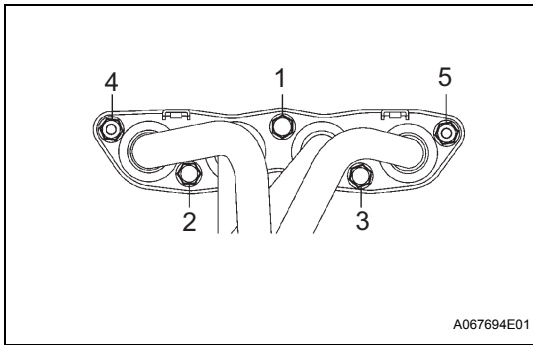

2. INSTALL EXHAUST MANIFOLD

- (a) Tighten the exhaust manifold nuts and bolts, in the order shown in the illustration, through a new gasket.

Torque: 27 N*m (275 kgf*cm, 20 ft.*lbf)

3. INSTALL MANIFOLD SUPPORT BRACKET

- (a) Install the manifold bracket with the 3 bolts.

Torque: 44 N*m (449 kgf*cm, 33 ft.*lbf)

4. INSTALL EXHAUST MANIFOLD HEAT INSULATOR NO.1

- (a) Install the exhaust manifold insulator with the 4 bolts.

Torque: 8.0 N*m (82 kgf*cm, 71 in.*lbf)

5. INSTALL WIRE HARNESS CLAMP BRACKET

- (a) Install the 2 wire harness clamp brackets with the 2 bolts.

Torque: 10 N*m (102 kgf*cm, 89 in.*lbf)

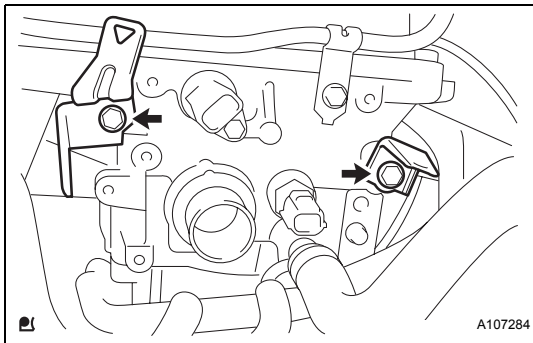

6. INSTALL ENGINE WIRE

- (a) Connect all the sensor connectors and wire harness clamps to the engine assembly and install the engine wire harness.

7. INSTALL BOOSTER VACUUM TUBE

- (a) Install the booster vacuum tube with the 2 bolts.

Torque: 9.0 N*m (92 kgf*cm, 80 in.*lbf)

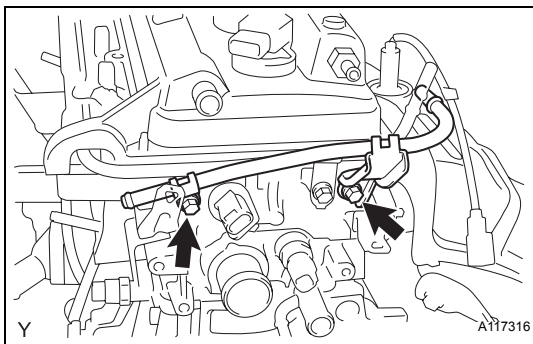

8. INSTALL WATER BY-PASS PIPE NO. 1

- (a) Install water by-pass pipe No. 1 through a new gasket with the 2 bolts and 2 nuts.

Torque: 9.0 N*m (92 kgf*cm, 80 in.*lbf)

9. INSTALL INTAKE MANIFOLD

- (a) Install a new gasket onto the intake manifold.

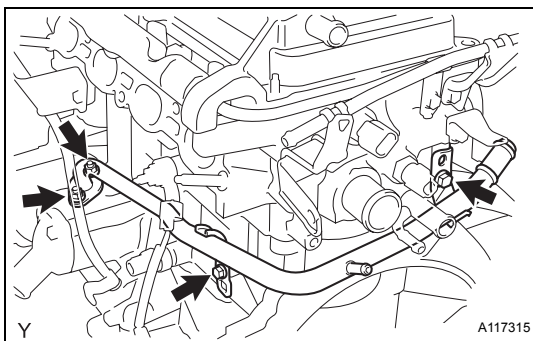

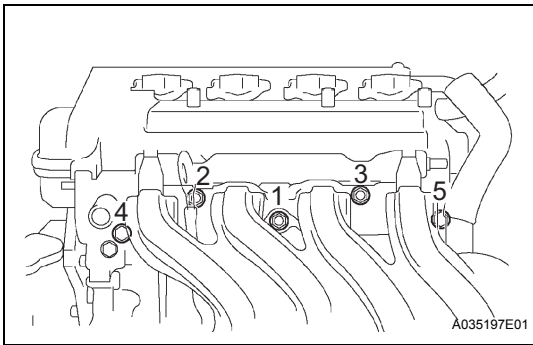

- (b) Provisionally tighten the intake manifold nuts and bolts in the order shown in the illustration, and then tighten them to the specified torque.
Torque: 30 N*m (306 kgf*cm, 22 ft.*lbf)
- (c) Connect the engine wire to the intake manifold.

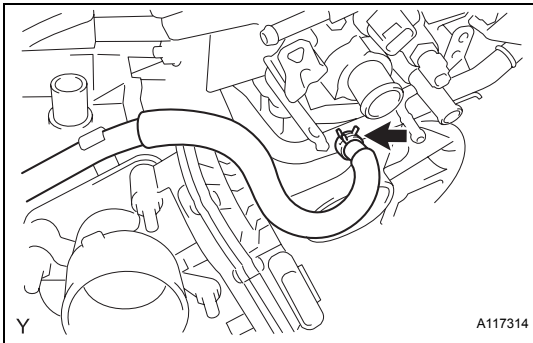

- (d) Connect the water by-pass hose to water bypass pipe No. 1.

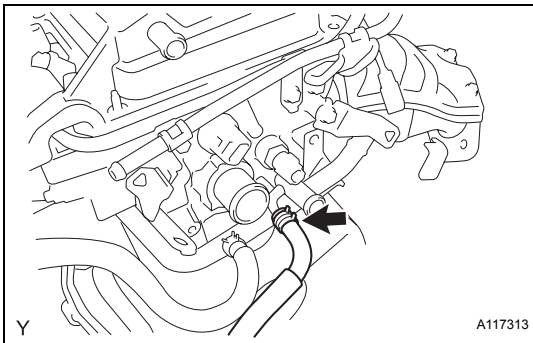

- (e) Connect the water by-pass hose to the cylinder head.
- (f) Connect the union to connector tube hose to the booster vacuum tube.
- (g) Connect the throttle with motor body assembly connector.

10. INSTALL OIL LEVEL GAUGE SUB-ASSEMBLY

11. INSTALL GENERATOR ASSEMBLY (See page [CH-17](#))

12. INSTALL IGNITION COIL NO.1 (See page [IG-9](#))

13. INSTALL DRIVE PLATE AND RING GEAR SUB-ASSEMBLY (for Automatic Transaxle)

- (a) Hold the crankshaft with SST.
SST 09960-10010 (09962-01000, 09963-01000)
- (b) Clean the 6 bolts and their holes.

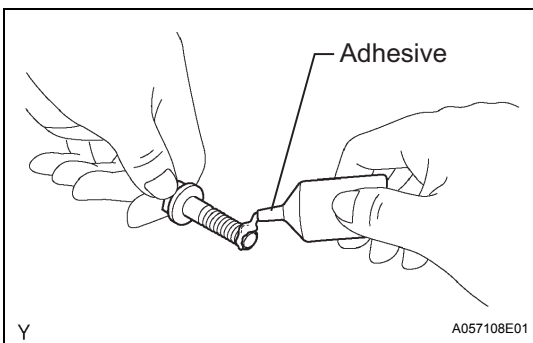
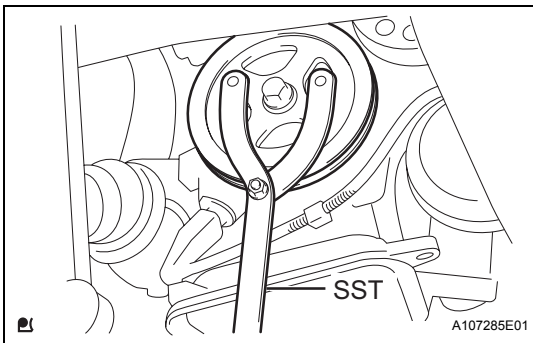

- (c) Apply adhesive to the end 2 or 3 threads of the bolts.
Adhesive:
Part No. 08833-0070, three bond 1324 or the equivalent.
- (d) Install the drive plate spacer RR, drive plate and ring gear sub-assembly and drive plate spacer FR.

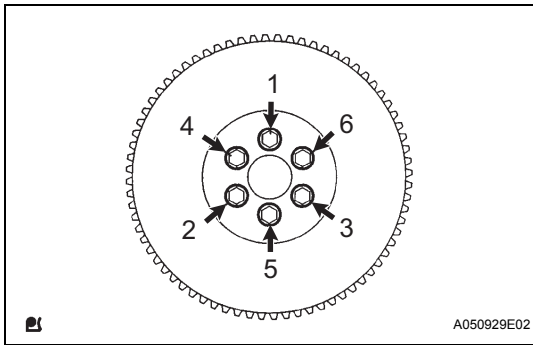

- (e) Install and uniformly tighten the 6 bolts in several steps, in the sequence shown in the illustration.

Torque: 88 N*m (900 kgf*cm, 65 ft.*lbf)

NOTICE:

Do not start the engine for at least 1 hour after performing the installation.

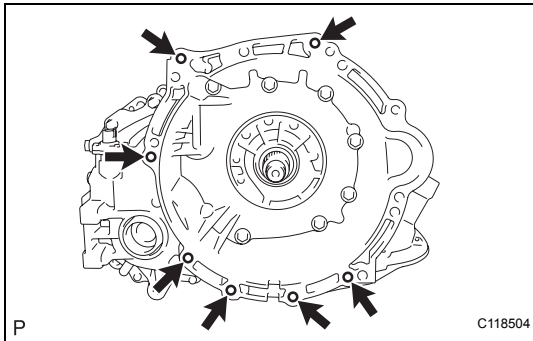

14. INSTALL AUTOMATIC TRANSAXLE ASSEMBLY (for Automatic Transaxle)

- (a) Make sure that the knock pin is installed on the engine side.
 (b) Install the automatic transaxle with torque converter with the 7 bolts.

Torque: 30 N*m (301 kgf*cm, 22 ft.*lbf)

CAUTION:

Make sure that the torque converter rotates.

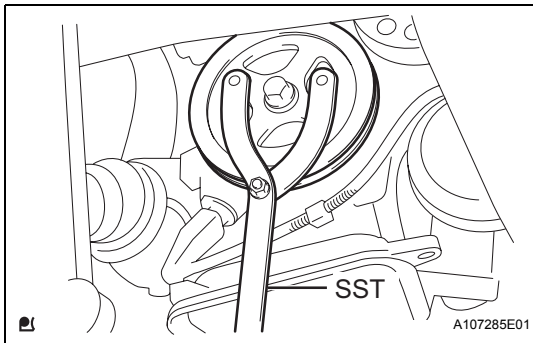

15. INSTALL FLYWHEEL SUB-ASSEMBLY (for Manual Transaxle)

- (a) Hold the crankshaft with SST.
SST 09960-10010 (09962-01000, 09963-01000)
 (b) Clean the 6 bolts and their holes.

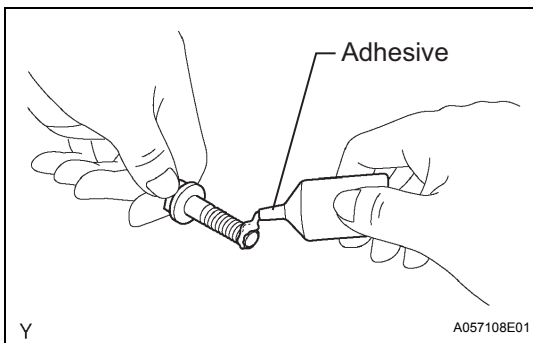

- (c) Apply adhesive to the end 2 or 3 threads of new bolts.

Adhesive:

Part No. 08833-0070, three bond 1324 or the equivalent.

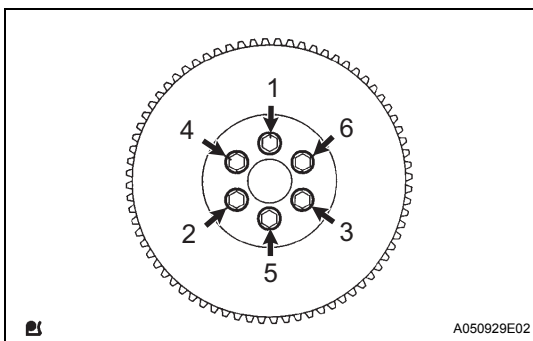

- (d) Install the flywheel with the 6 bolts in the order shown in the illustration.

Torque: 49 N*m (500 kgf*cm, 38 ft.*lbf)

- (e) Mark a paint mark on each bolt head on the engine upper side.

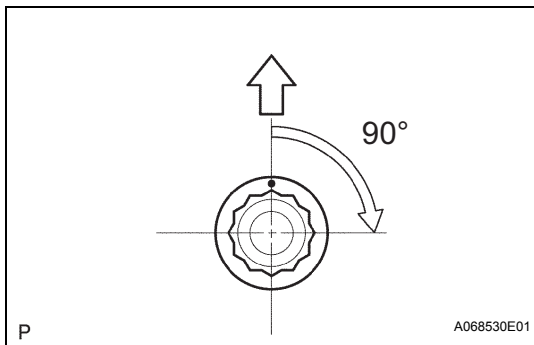

- (f) Tighten the bolts 90° in the sequence shown in the illustration.

NOTICE:

Do not start the engine for at least 1 hour after performing the installation.

16. **INSTALL CLUTCH DISC ASSEMBLY** (for Manual Transaxle) (See page [CL-16](#))
17. **INSTALL CLUTCH COVER ASSEMBLY** (for Manual Transaxle) (See page [CL-17](#))
18. **INSPECT AND ADJUST CLUTCH COVER ASSEMBLY** (for Manual Transaxle) (See page [CL-17](#))
19. **INSTALL MANUAL TRANSAXLE ASSEMBLY** (for Manual Transaxle) (See page [MX-30](#))
20. **INSTALL CONTROL CABLE BRACKET** (for Manual Transaxle) (See page [MX-32](#))
21. **INSTALL STARTER ASSEMBLY** (See page [ST-17](#))
22. **INSTALL FLYWHEEL HOUSING SIDE COVER** (See page [ST-17](#))
23. **CONNECT HEATER WATER INLET HOSE A**
 - (a) Connect heater water inlet hose A to the cylinder head.
24. **INSTALL WATER FILLER SUB-ASSEMBLY**
 - (a) Connect radiator hose No. 1 to the cylinder head.
 - (b) Install the water filler sub-assembly with the 2 nuts.
Torque: 7.5 N*m (76 kgf*cm, 66 in.*lbf)
 - (c) Connect radiator hose No. 1 to the water filler.
25. **INSTALL FUEL TUBE SUB-ASSEMBLY**
 - (a) Connect the fuel tube connector and pipe and install fuel pipe clamp No. 2.
CAUTION:
Align the fuel tube connector with the pipe, then push the fuel tube connector in until the retainer makes a click sound. If the connection is tight, apply a small amount of engine oil to the the tip of the pipe. After connecting, pull the pipe and connector to make sure that they are securely connected.
26. **INSTALL VENTILATION HOSE NO. 2**
 - (a) Install ventilation hose No. 2 with the clip.
27. **INSTALL VENTILATION HOSE**
 - (a) Install the ventilation hose with the clip.
28. **INSTALL FRONT SUSPENSION CROSSMEMBER SUB-ASSEMBLY**
 - (a) Install the engine moving control rod with the through bolt.
Torque: 120 N*m (1,224 kgf*cm, 89 ft.*lbf)
 - (b) Remove the 2 bolts and remove the 2 engine hangers.

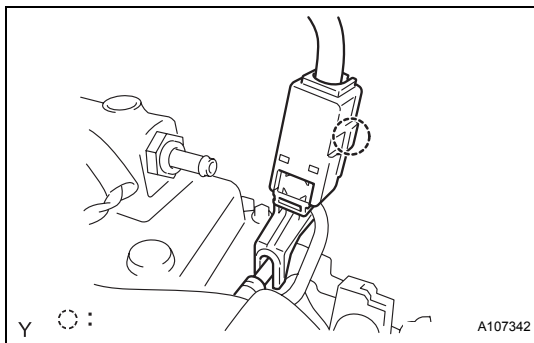

- (c) Install the oxygen sensor wiring bracket with the bolt.
Torque: 60 N*m (612 kgf*cm, 44 ft.*lbf)
- (d) Install the radio setting condenser with the bolt.
Torque: 40 N*m (408 kgf*cm, 30 ft.*lbf)

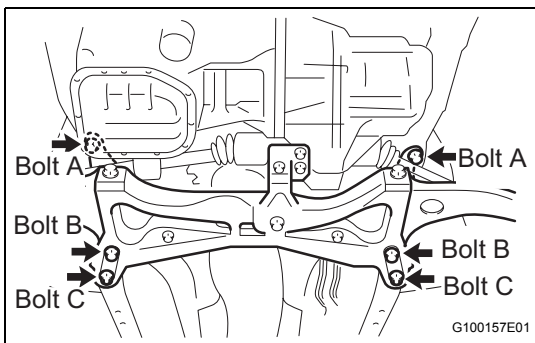
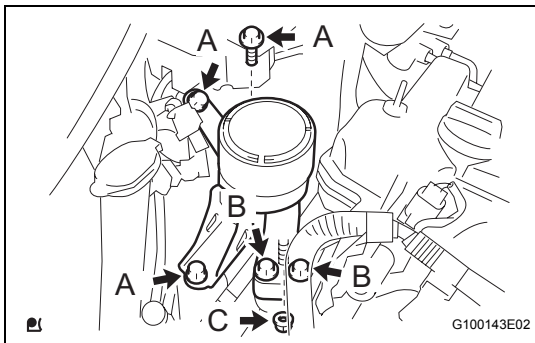
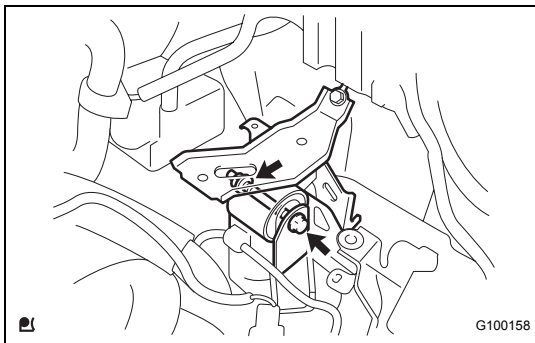
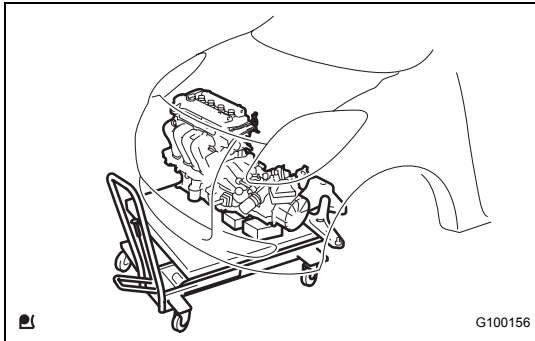

29. INSTALL ENGINE ASSEMBLY WITH TRANSAXLE (for Hatchback)

- (a) Set the engine assembly with transaxle and front suspension crossmember on the engine lifter.
- (b) Operate the engine lifter and lift the engine assembly with transaxle and front suspension crossmember to the position where the engine mounting insulators RH and LH can be installed.
- (c) Install the engine mounting insulator LH with the through bolt and nut.
Torque: 52 N*m (530 kgf*cm, 38 ft.*lbf)
- (d) Install the engine mounting insulator RH with the 5 bolts and nut.
Torque: 45 N*m (459 kgf*cm, 33 ft.*lbf) for Bolt A
52 N*m (530 kgf*cm, 38 ft.*lbf) for Bolt B
52 N*m (530 kgf*cm, 38 ft.*lbf) for Nut C
- (e) Operate the engine lifter and provisionally install the front suspension crossmember onto the vehicle with the 6 bolts.
- (f) Insert SST into the datum holes in the front suspension crossmembers RH and LH alternately and tighten bolts A, B and C on both sides in several sequences.
SST 09670-00010
Torque: 70 N*m (714 kgf*cm, 52 ft.*lbf) for Bolt A
160 N*m (1,631 kgf*cm, 118 ft.*lbf) for Bolt B
95 N*m (969 kgf*cm, 70 ft.*lbf) for Bolt C
- CAUTION:**
- Insert SST into the datum hole vertically.
 - If impossible to insert SST vertically, loosen all the bolts and then insert SST again.

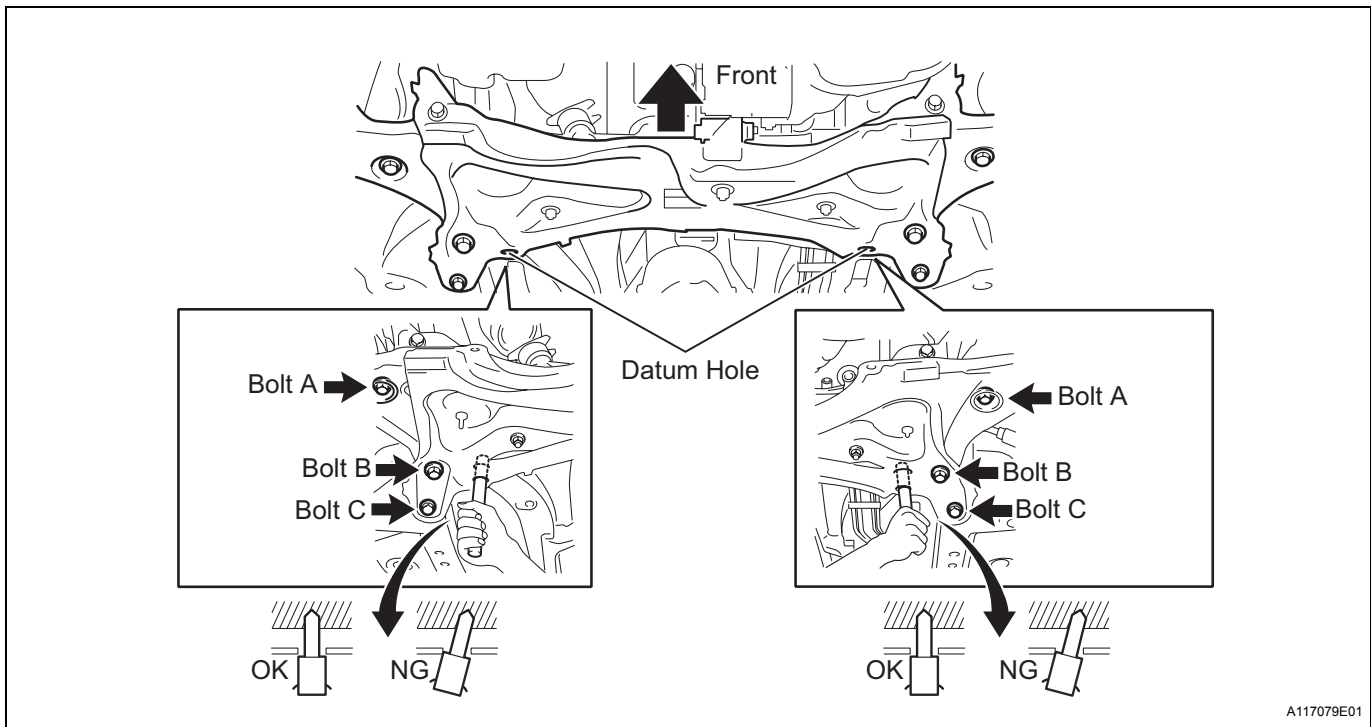

30. REMOVE ENGINE ASSEMBLY WITH TRANSAXLE (for Sedan)

- Set the engine assembly with transaxle and front suspension crossmember on the engine lifter.
- Operate the engine lifter and lift the engine assembly with transaxle and front suspension crossmember to the position where the engine mounting insulators RH and LH can be installed.

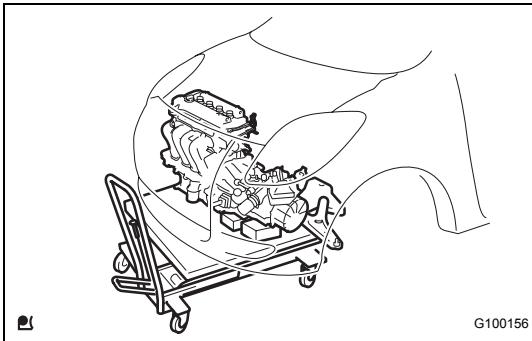

- Install the engine mounting insulator LH with the through bolt and nut.

Torque: 52 N*m (530 kgf*cm, 38 ft.*lbf)

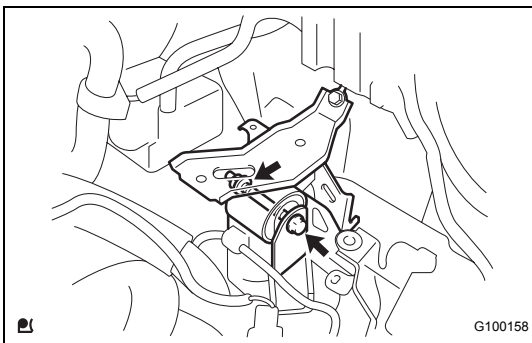

- Install the engine mounting insulator RH with the 5 bolts and nut.

Torque: 52 N*m (530 kgf*cm, 38 ft.*lbf)

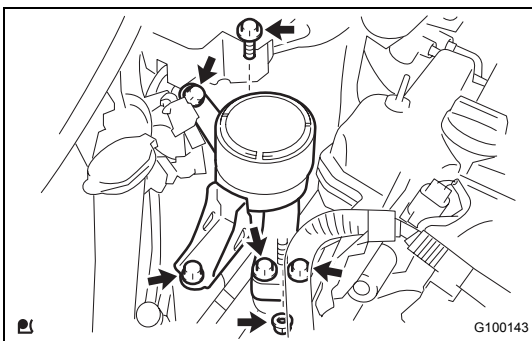

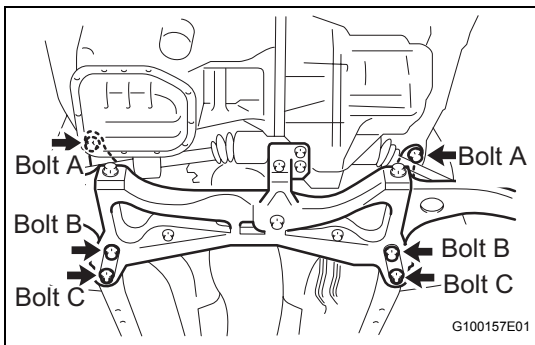

- (e) Operate the engine lifter and provisionally install the engine assembly with transaxle and front suspension crossmember onto the vehicle with the 6 bolts.
- (f) Insert SST into the datum holes of the front suspension crossmembers RH and LH alternately and tighten bolts A, B and C on both sides in several sequences.

SST 09670-00010

Torque: 70 N*m (714 kgf*cm, 52 ft.*lbf) for Bolt A
160 N*m (1,631 kgf*cm, 118 ft.*lbf) for Bolt B

95 N*m (969 kgf*cm, 70 ft.*lbf) for Bolt C

CAUTION:

- Insert SST into the datum hole vertically.
- If impossible to insert SST vertically, loosen all the bolts and then insert SST again.

EM

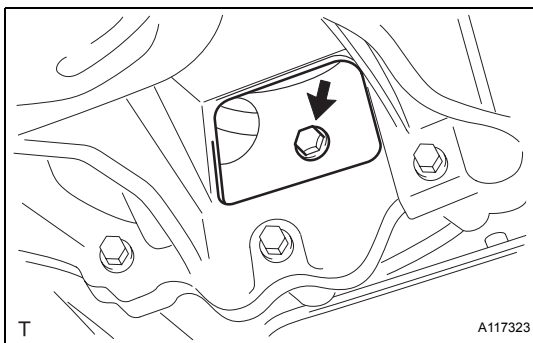
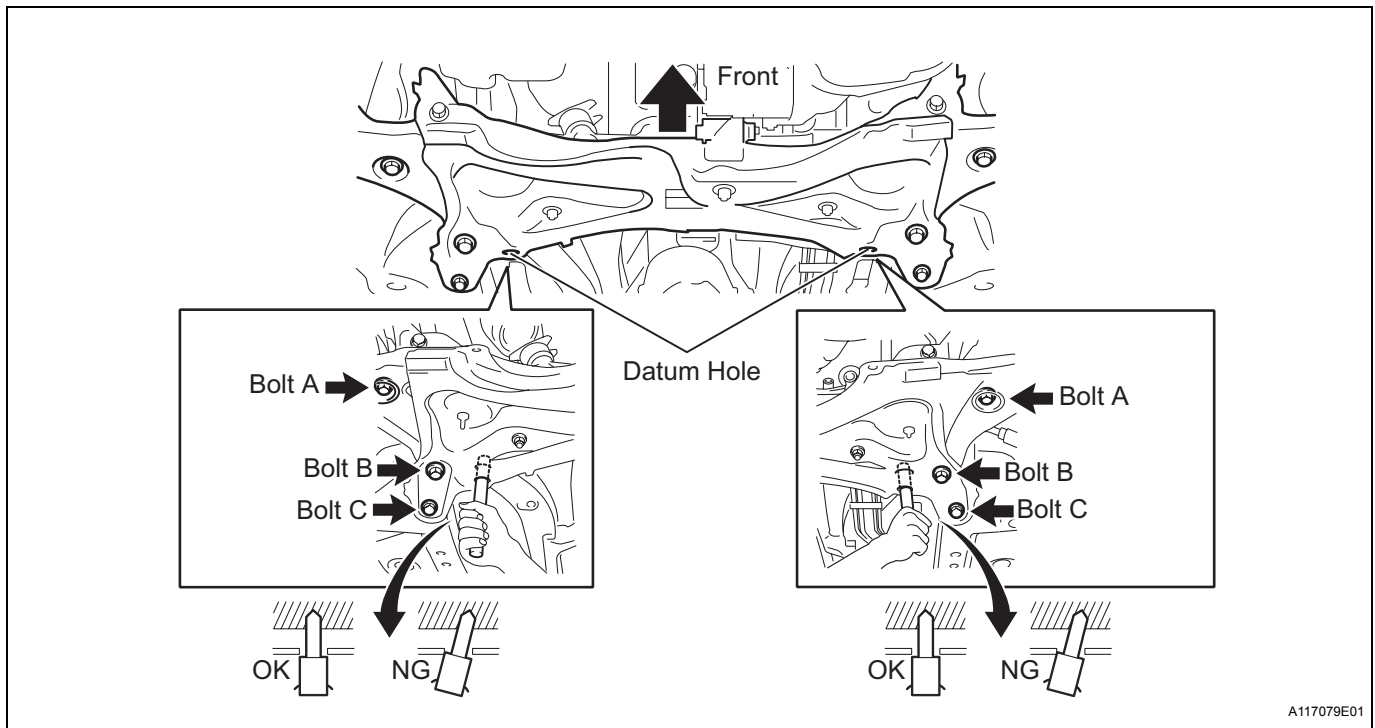

31. INSTALL DRIVE PLATE AND TORQUE CONVERTER CLUTCH SETTING BOLT (for Automatic Transaxle)

- (a) Tighten the 6 torque converter set bolts.

Torque: 27 N*m (275 kgf*cm, 20 ft.*lbf)

32. INSTALL FLYWHEEL HOUSING UNDER COVER

33. INSTALL FRONT DRIVE SHAFT ASSEMBLY LH (See page DS-13)

34. INSTALL FRONT DRIVE SHAFT ASSEMBLY RH (See page DS-14)

35. INSTALL FRONT AXLE ASSEMBLY LH (See page DS-14)

36. INSTALL FRONT AXLE ASSEMBLY RH (See page DS-14)

37. INSTALL FRONT STABILIZER LINK ASSEMBLY LH (See page [DS-14](#))
38. INSTALL FRONT STABILIZER LINK ASSEMBLY RH (See page [MX-31](#))
39. INSTALL FRONT SUSPENSION ARM SUB-ASSEMBLY LOWER NO. 1 LH (See page [DS-14](#))
40. INSTALL FRONT SUSPENSION ARM SUB-ASSEMBLY LOWER NO. 1 RH (See page [MX-31](#))
41. INSTALL TIE ROD END SUB-ASSEMBLY LH (See page [DS-15](#))
42. INSTALL TIE ROD END SUB-ASSEMBLY RH (See page [MX-31](#))
43. INSTALL SPEED SENSOR FRONT LH (w/ ABS) (See page [DS-15](#))
44. INSTALL SPEED SENSOR FRONT RH (w/ ABS) (See page [MX-31](#))
45. INSTALL FRONT AXLE HUB LH NUT (See page [DS-15](#))
46. INSTALL FRONT AXLE HUB RH NUT (See page [MX-31](#))
47. INSTALL EXHAUST PIPE ASSEMBLY FRONT (See page [EX-8](#))
48. INSTALL HEATED OXYGEN SENSOR (See page [EC-23](#))
49. INSTALL CONSOLE BOX ASSEMBLY REAR (See page [PB-10](#))
50. INSTALL CONSOLE BOX REAR COVER (for Hatchback) (See page [PB-11](#))
51. INSTALL SHIFTING HOLE COVER SUB-ASSEMBLY (for Manual Transaxle) (See page [PB-12](#))
52. INSTALL CONSOLE BOX CARPET (for Sedan) (See page [PB-11](#))
53. INSTALL CONSOLE UPPER REAR PANEL SUB-ASSEMBLY (for Sedan) (See page [IP-89](#))
54. INSTALL UPPER CONSOLE PANEL SUB-ASSEMBLY (for Sedan) (See page [IP-89](#))
55. INSTALL INSTRUMENT PAD LOWER LH (for Sedan) (See page [IP-55](#))
56. INSTALL INSTRUMENT PANEL FINISH PANEL END LH (for Sedan) (See page [ME-141](#))
57. INSTALL INSTRUMENT PANEL FINISH PANEL LOWER CENTER (for Sedan) (See page [ME-142](#))
58. INSTALL SHIFT LEVER KNOB SUB-ASSEMBLY (for Manual Transaxle)

59. INSTALL STEERING COLUMN HOLE COVER SUB-ASSEMBLY NO. 1 (See page [PS-79](#))
60. INSTALL STEERING SLIDING YOKE SUB-ASSEMBLY (See page [PS-79](#))
61. INSTALL COLUMN HOLE COVER SILENCER SHEET (See page [PS-79](#))
62. CONNECT ENGINE WIRE

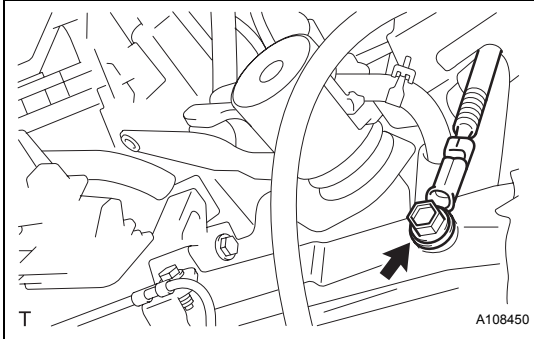

- (a) Install the earth wire of the engine room wire harness with the bolt.

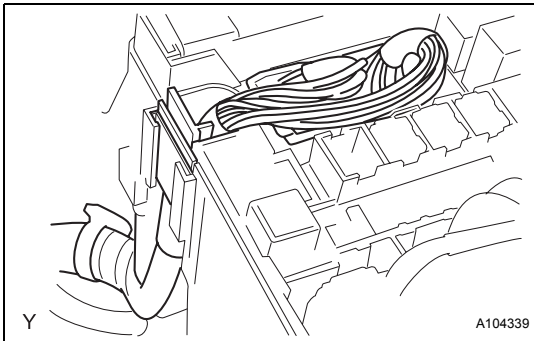

- (b) Connect the 2 engine wire harness connectors and wire harness clamp to the engine room junction block.

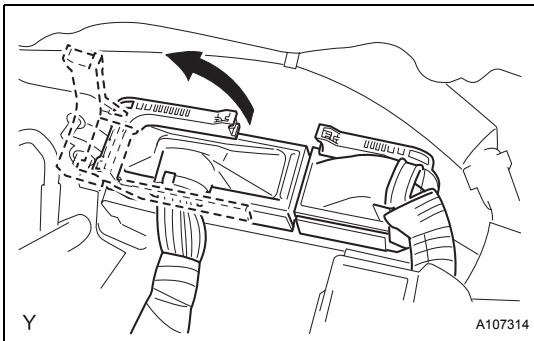

- (c) Connect the engine wire harness connector to the ECM.

63. INSTALL CLUTCH RELEASE CYLINDER ASSEMBLY (for Manual Transaxle) (See page [MX-32](#))
64. INSTALL WITH PULLEY COMPRESSOR ASSEMBLY (w/ Air Conditioning System) (See page [AC-209](#))
65. INSTALL FAN AND GENERATOR V BELT (See page [EM-7](#))
66. ADJUST FAN AND GENERATOR V BELT (See page [EM-7](#))
67. CONNECT FUEL TUBE SUB-ASSEMBLY

- (a) Connect the fuel tube connector and fuel pipe, and install fuel pipe clamp No. 1.

CAUTION:

Align the fuel tube connector with the pipe, then push the fuel tube connector in until the retainer makes a click sound. If the connection is tight, apply a small amount of engine oil to the tip of the pipe. After connecting, pull the pipe and connector to make sure that they are securely connected.

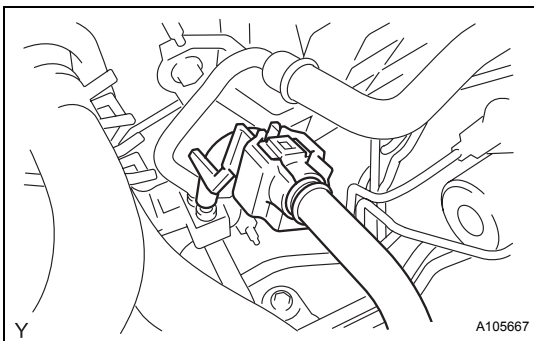

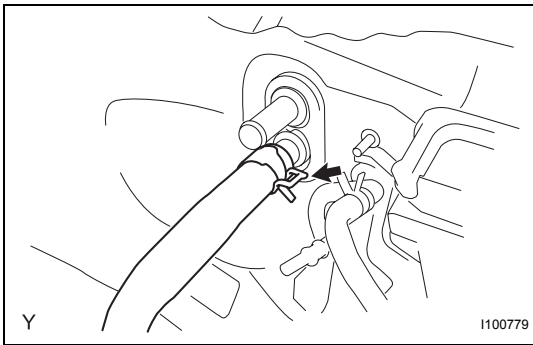
**68. CONNECT HEATER WATER INLET HOSE A**

- (a) Connect heater water inlet hose A to the heater unit.

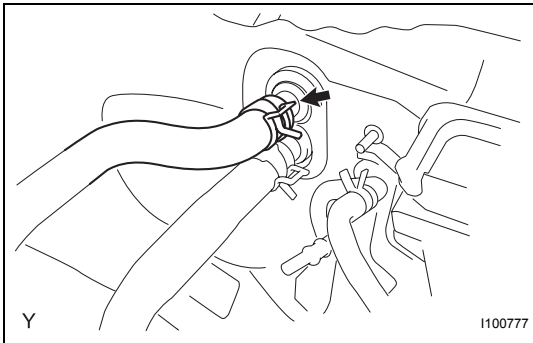
**69. CONNECT HEATER WATER OUTLET HOSE A (FROM HEATER UNIT)**

- (a) Connect heater water outlet hose A to the heater unit.

70. CONNECT UNION TO CHECK VALVE HOSE

- (a) Connect the union to check valve hose to the booster vacuum tube.

71. INSTALL TRANSMISSION CONTROL CABLE ASSEMBLY (for Automatic Transaxle) (See page [AX-109](#))**72. INSTALL TRANSMISSION CONTROL CABLE ASSEMBLY (for Manual Transaxle) (See page [MX-32](#))****73. INSTALL CYLINDER HEAD COVER NO. 2 (See page [IG-10](#))****74. CONNECT OIL COOLER INLET HOSE (for Automatic Transaxle)**

- (a) Connect the oil cooler inlet hose with the clip.

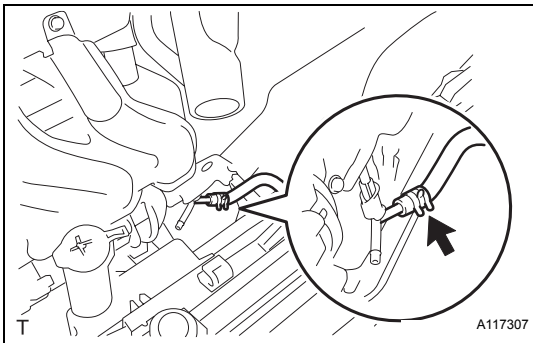
**75. CONNECT OIL COOLER OUTLET HOSE (for Automatic Transaxle)**

- (a) Connect the oil cooler outlet hose with the clip.

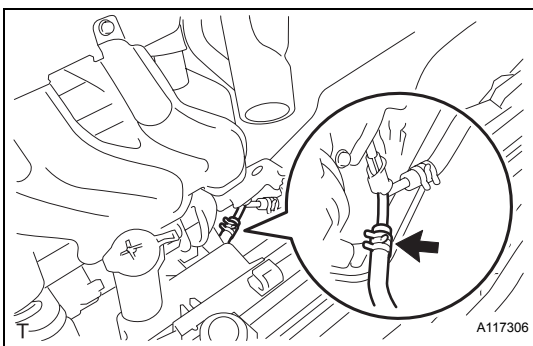

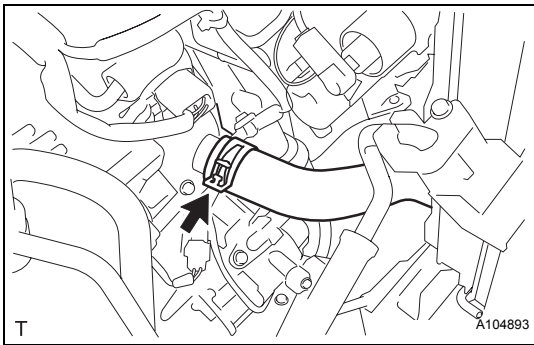
**76. CONNECT RADIATOR HOSE NO. 2**

- (a) Connect radiator hose No. 2 to the water inlet.

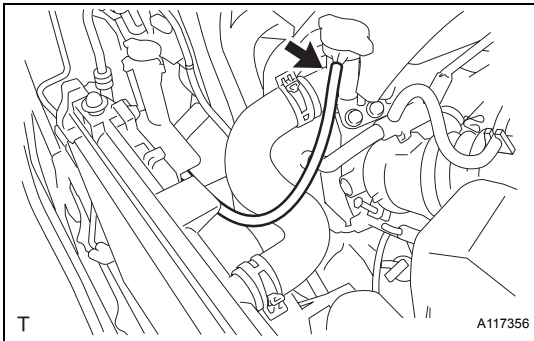
**77. CONNECT RADIATOR RESERVOIR TANK HOSE**

- (a) Connect the radiator reservoir tank hose to the water filler.

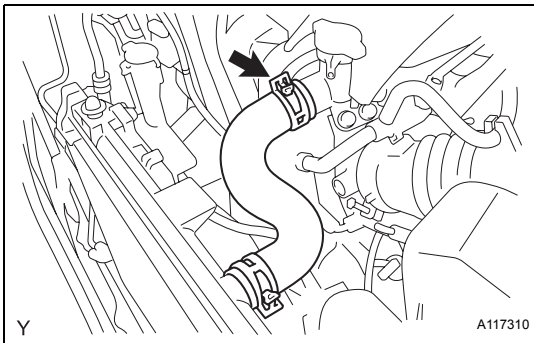
**78. CONNECT RADIATOR HOSE NO. 3**

- (a) Connect radiator hose No. 3 to the water filler.

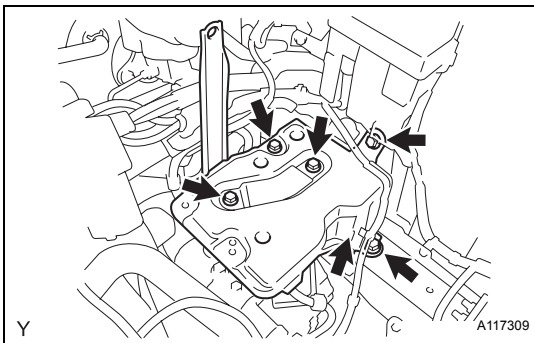
**79. INSTALL BATTERY CARRIER**

- (a) Install the battery carrier with the 5 bolts.
Torque: 17 N*m (173 kgf*cm, 13 ft.*lbf)
- (b) Install the clamp.

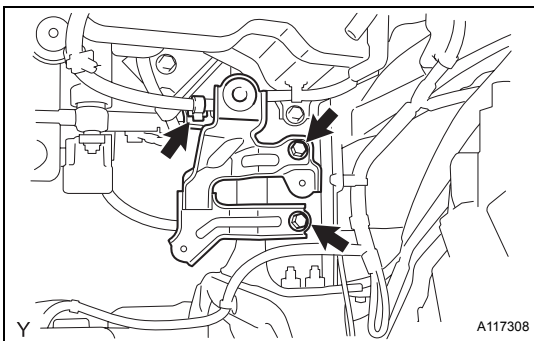
**80. INSTALL AIR CLEANER BRACKET**

- (a) Install the air cleaner bracket with the 2 bolts.
Torque: 19 N*m (194 kgf*cm, 14 ft.*lbf)
- (b) Connect the wire harness clamp to the air cleaner bracket.

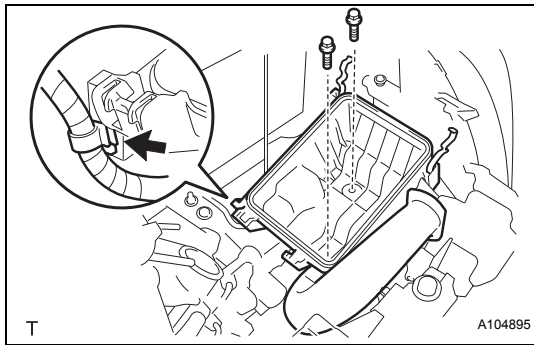
**81. INSTALL AIR CLEANER ASSEMBLY**

- (a) Install the air cleaner case with air cleaner inlet No. 1 with the 2 bolts.

Torque: 7.8 N*m (80 kgf*cm, 69 in.*lbf)

- (b) Connect the wire harness to the air cleaner case.
 (c) Install the air cleaner element.

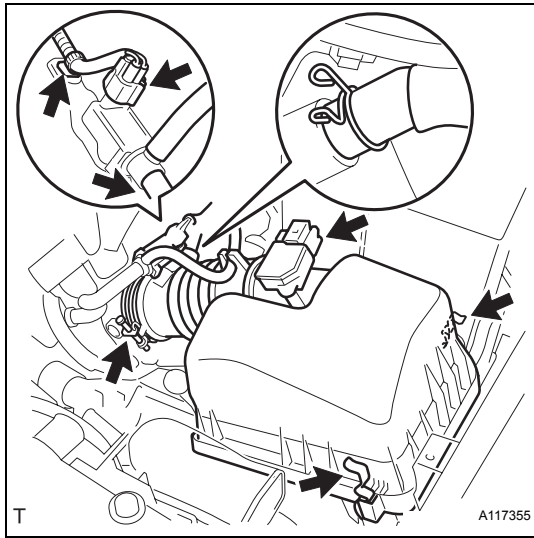

- (d) Install and lock the air cleaner cap and the air cleaner hose and then tighten the air cleaner hose clamp.

Torque: 4.0 N*m (41 kgf*cm, 35 in.*lbf)

- (e) Connect the ventilation hose to the air cleaner hose.
 (f) Connect the vacuum switching valve connector and the wire harness clamp.
 (g) Connect the fuel vapor feed hose and fuel vapor feed hose No. 1 to the vacuum switching valve assembly.
 (h) Connect the intake air flow meter connector and the wire harness clamp.

82. INSTALL COWL TOP PANEL OUTER (for Hatchback)

- (a) Install the cowl top panel with the 9 bolts.

Torque: 6.5 N*m (66 kgf*cm, 58 ft.*lbf)

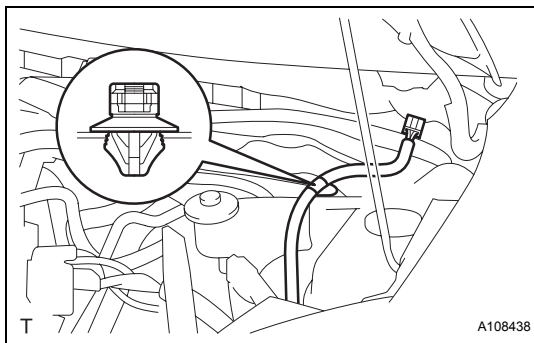
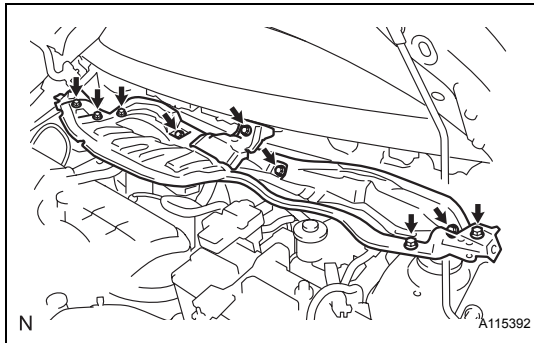

- (b) Connect the wire harness clamp.

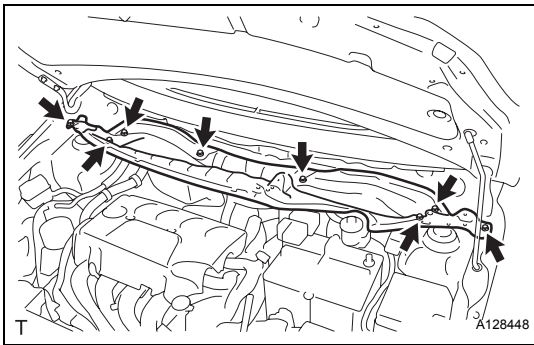
**83. INSTALL COWL TOP PANEL OUTER (for Sedan)**

- (a) Install the cowl top panel outer with the 8 bolts.
Torque: 6.5 N*m (66 kgf*cm, 58 in.*lbf)

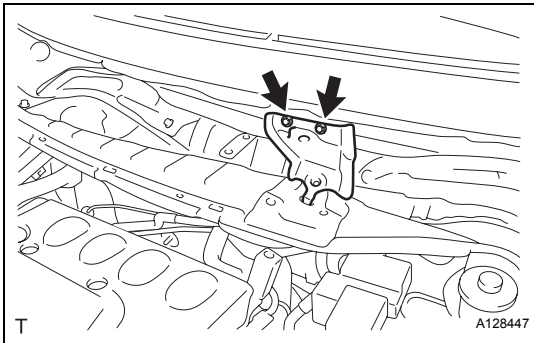

- (b) Install the cowl top to cowl inner brace with the 2 bolts.
Torque: 6.5 N*m (66 kgf*cm, 58 in.*lbf)

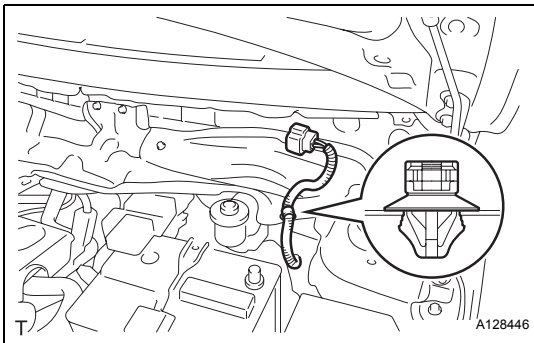

- (c) Connect the wire harness clamp.

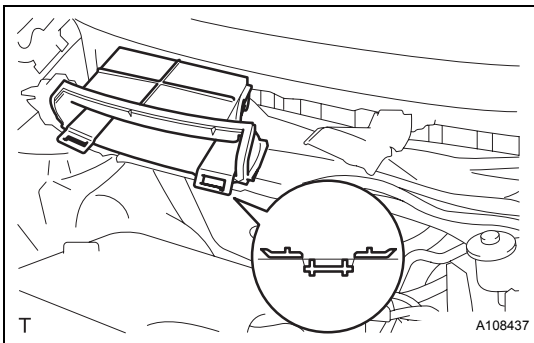
**84. INSTALL COWL TO REGISTER DUCT SUB-ASSEMBLY NO. 2 (for Hatchback)**

- (a) Engage the claw and install cowl to register duct No. 2.

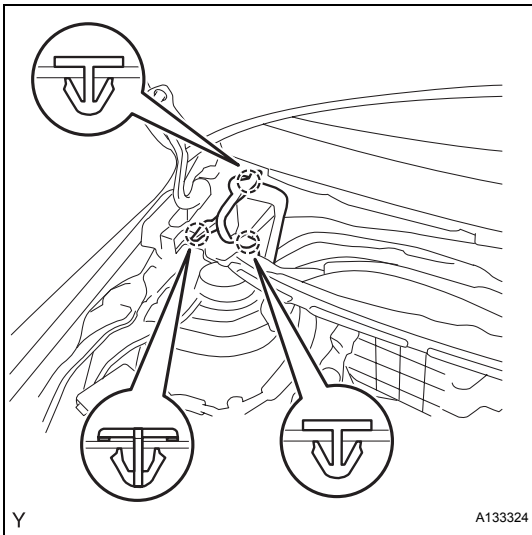

85. **INSTALL FRONT AIR SHUTTER SEAL RH (for Sedan)**
 - (a) Engage the 3 claws to install the front air shutter seal RH.
86. **INSTALL FRONT WIPER MOTOR AND LINK (See page [WW-21](#))**
87. **INSTALL COWL TOP VENTILATOR LOUVER LH (for Hatchback) (See page [WW-21](#))**
88. **INSTALL COWL TOP VENTILATOR LOUVER SUB-ASSEMBLY (for Hatchback) (See page [WW-21](#))**
89. **INSTALL HOOD TO COWL TOP SEAL (for Hatchback) (See page [WW-22](#))**
90. **INSTALL COWL TOP VENTILATOR LOUVER SUB-ASSEMBLY (for Sedan) (See page [WW-12](#))**
91. **INSTALL COWL SIDE VENTILATOR SUB-ASSEMBLY LH (for Sedan) (See page [WW-13](#))**
92. **INSTALL COWL SIDE VENTILATOR SUB-ASSEMBLY RH (for Sedan) (See page [WW-13](#))**
93. **INSTALL FRONT WIPER ARM LH (See page [WW-22](#))**
94. **INSTALL FRONT WIPER ARM RH (See page [WW-23](#))**
95. **INSTALL FRONT WIPER ARM HEAD CAP (See page [WW-23](#))**
96. **INSTALL BATTERY TRAY**
97. **INSTALL BATTERY**
 - (a) Install the battery onto the vehicle with the battery clamp.
Torque: 3.5 N*m (36 kgf*cm, 31 in.*lbf)
 - (b) Connect the cable to the battery terminal.
Torque: 5.4 N*m (55 kgf*cm, 48 in.*lbf)
98. **ADD ENGINE COOLANT (See page [CO-8](#))**
99. **ADD AUTOMATIC TRANSAXLE FLUID (for Automatic Transaxle) (See page [AX-169](#))**
100. **INSPECT AUTOMATIC TRANSAXLE FLUID (for Automatic Transaxle) (See page [AX-93](#))**
101. **ADD MANUAL TRANSAXLE OIL (for Manual Transaxle)**
102. **INSPECT MANUAL TRANSAXLE OIL (for Manual Transaxle) (See page [MX-2](#))**
103. **INSPECT FAN AND GENERATOR V BELT (See page [EM-8](#))**
104. **CHECK FOR FUEL LEAKAGE (See page [FU-7](#))**
105. **CHECK FOR ENGINE OIL LEAKAGE**
106. **CHECK FOR EXHAUST GAS LEAKAGE**
107. **CHECK FOR ENGINE COOLANT LEAKAGE (See page [CO-1](#))**

-
- 108. INSTALL ENGINE UNDER COVER RH
 - 109. INSTALL ENGINE UNDER COVER LH
 - 110. INSTALL FRONT WHEELS
Torque: 103 N*m (1,050 kgf*cm, 76 ft.*lbf)
 - 111. INSPECT IGNITION TIMING (See page [EM-1](#))
 - 112. INSPECT ENGINE IDLING SPEED (See page [EM-2](#))
 - 113. INSPECT CO/HC (See page [EM-4](#))
 - 114. INSPECT FRONT WHEEL ALIGNMENT
 - 115. INSPECT ABS SENSOR SIGNAL (w/ ABS)

ENGINE UNIT

COMPONENTS

EM

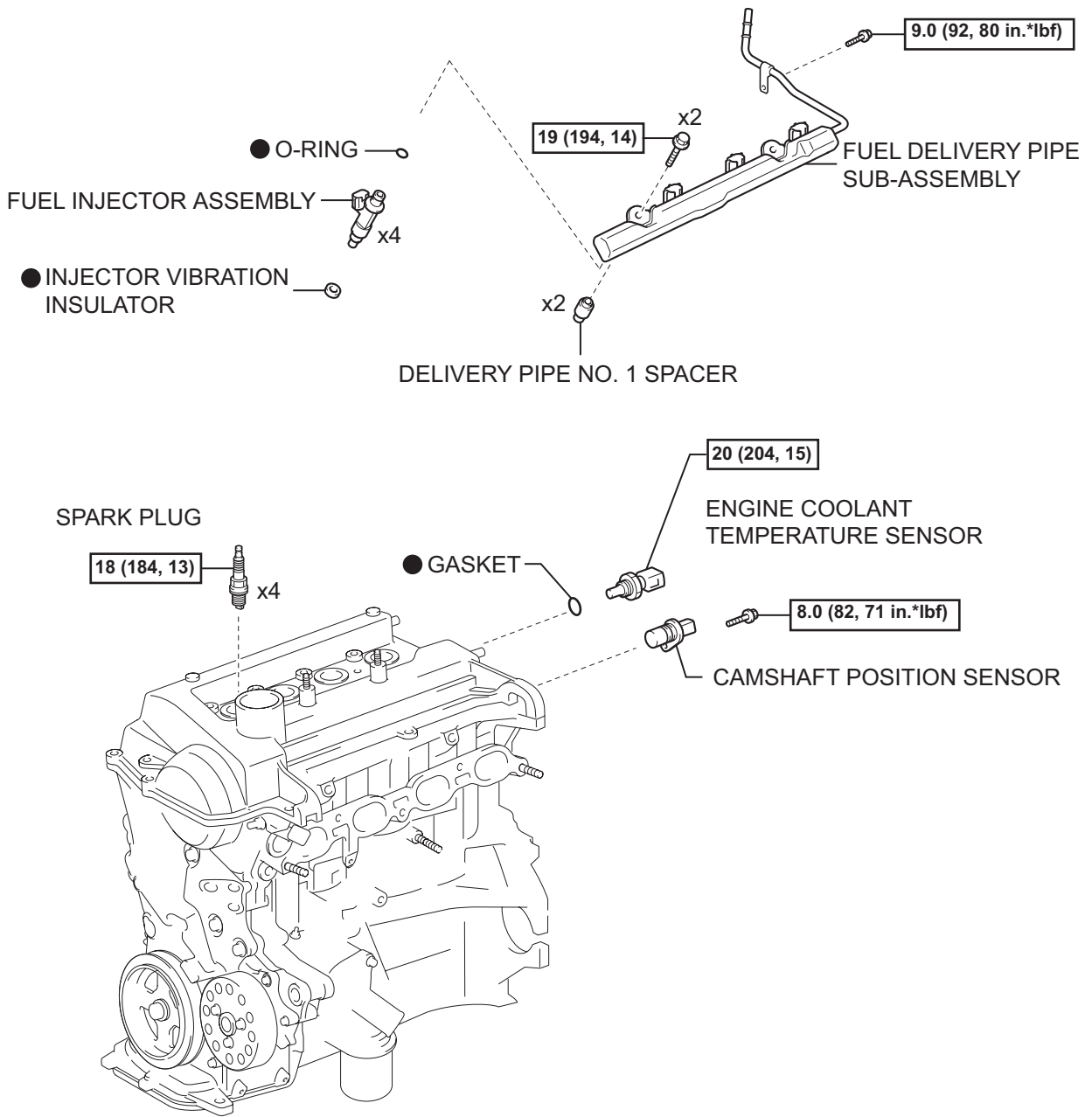

N*m (kgf*cm, ft.*lbf) : Specified torque

● Non-reusable part

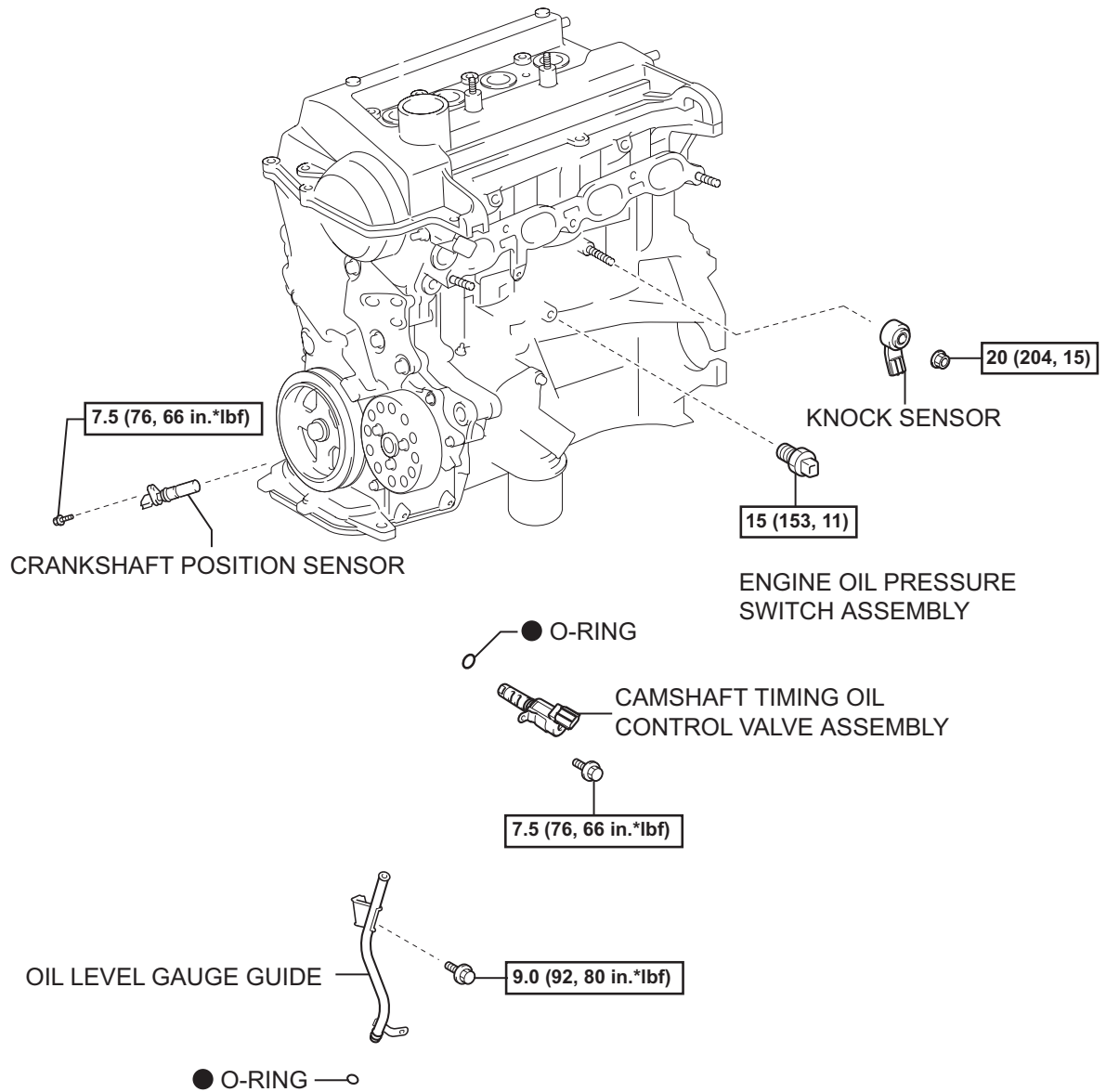

N*m (kgf*cm, ft.*lbf) : Specified torque

● Non-reusable part

EM

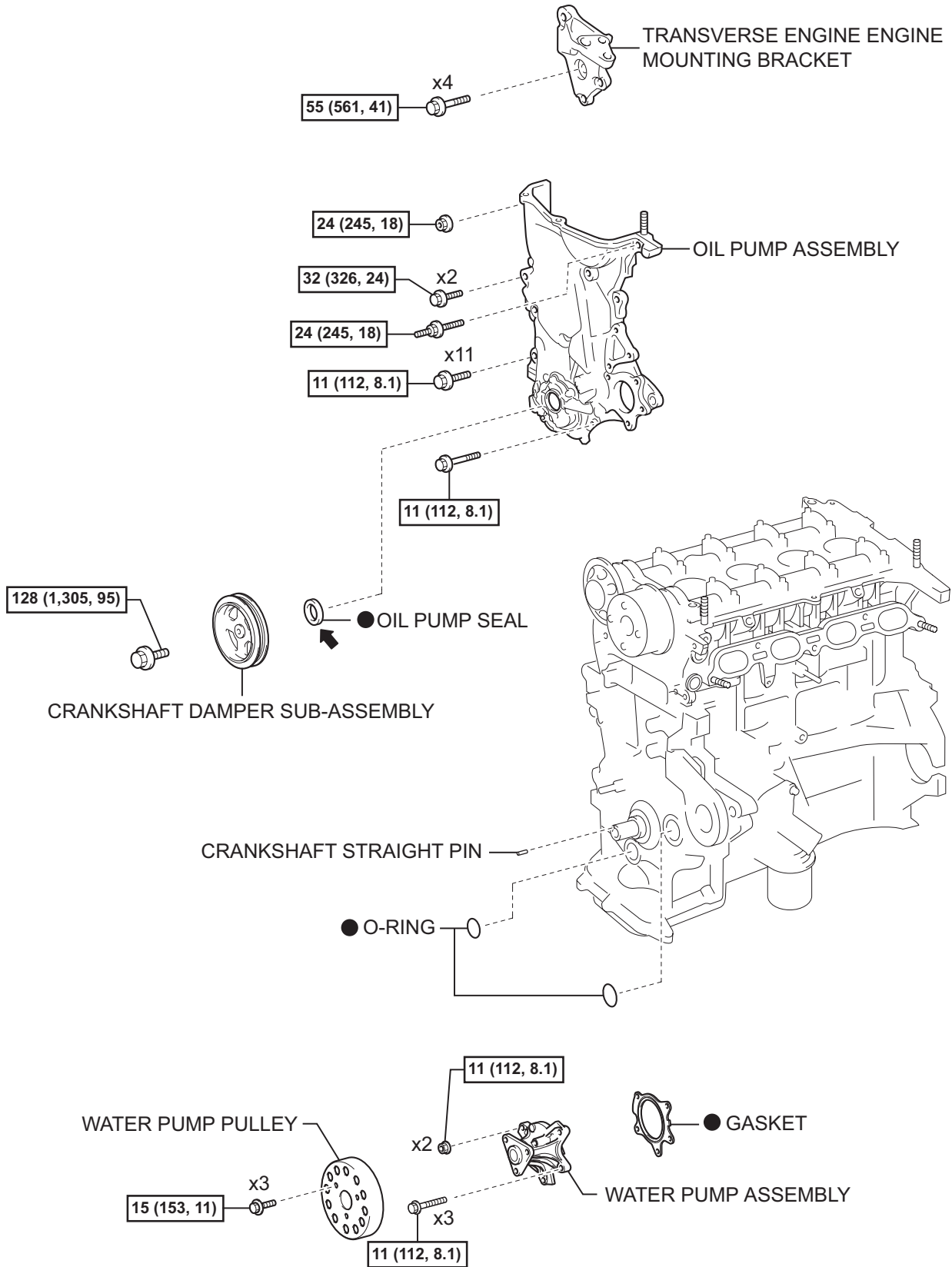

N*m (kgf*cm, ft.*lbf) : Specified torque

● Non-reusable part

◀ Apply MP grease

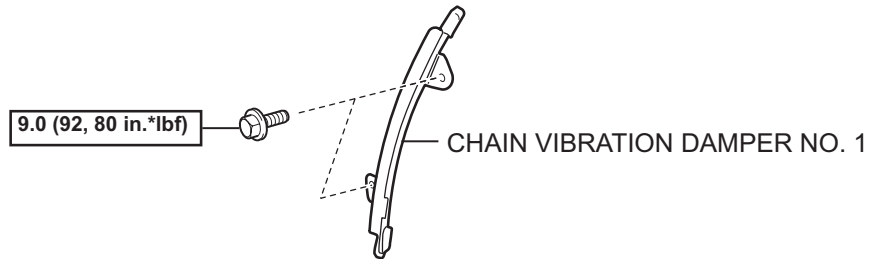
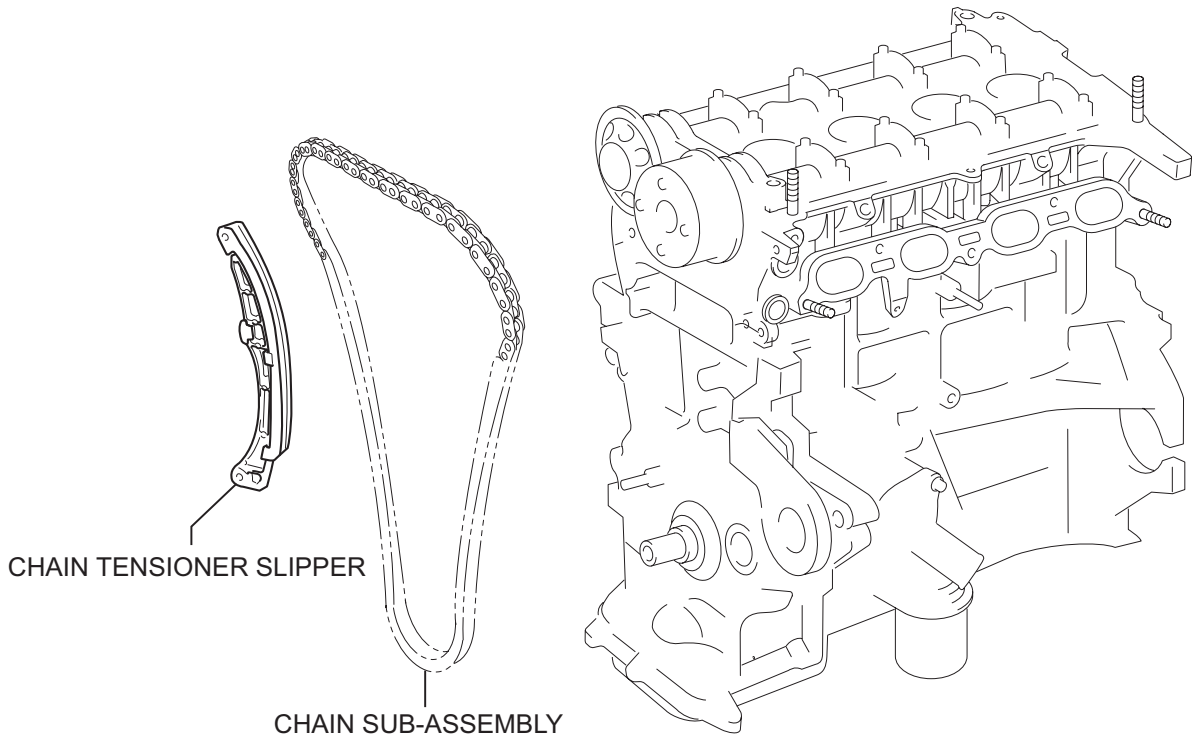
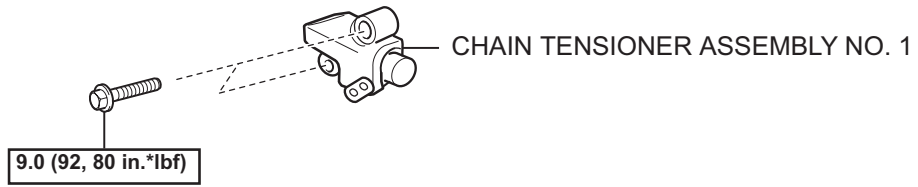

N*m (kgf*cm, ft.*lbf) : Specified torque

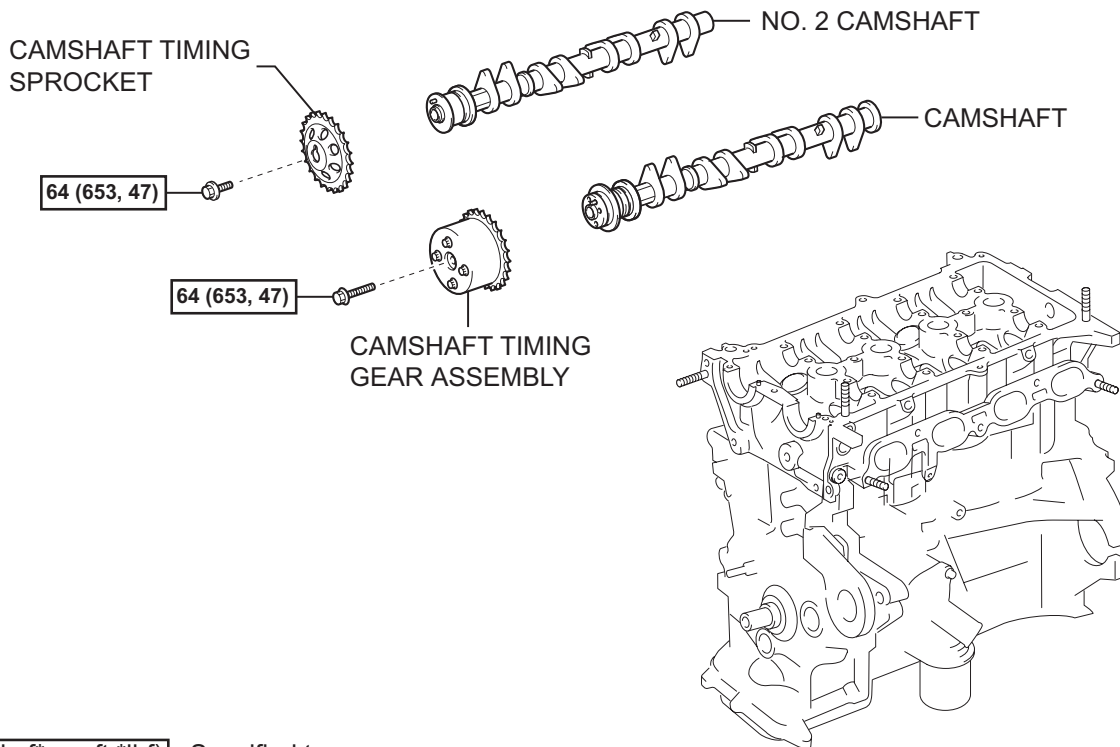
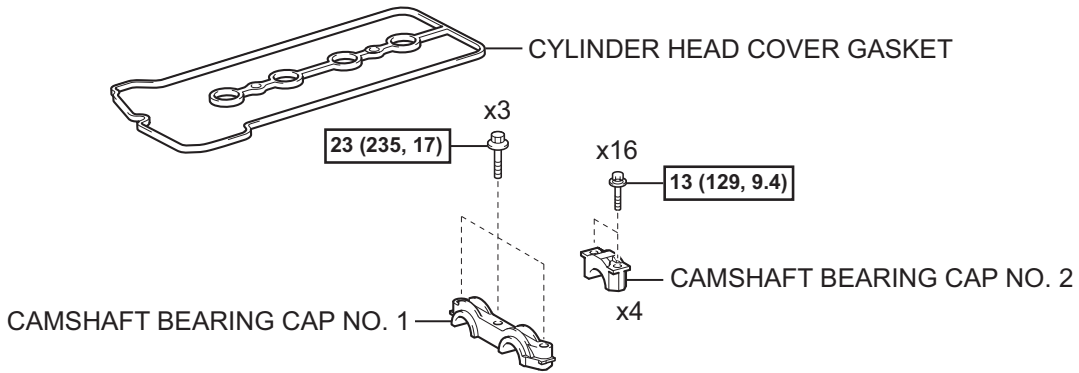
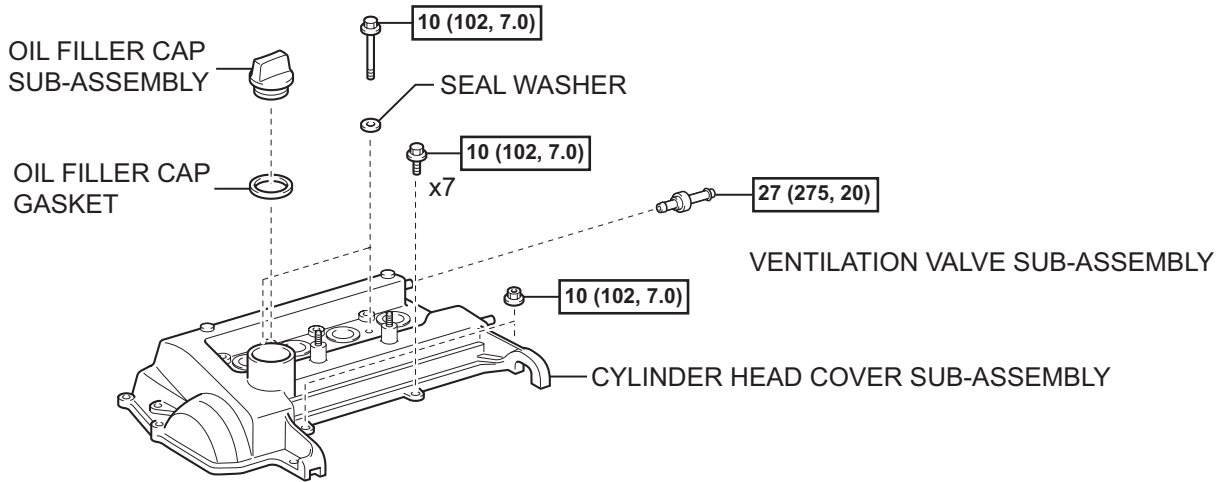

N*m (kgf*cm, ft.*lbf) : Specified torque

EM

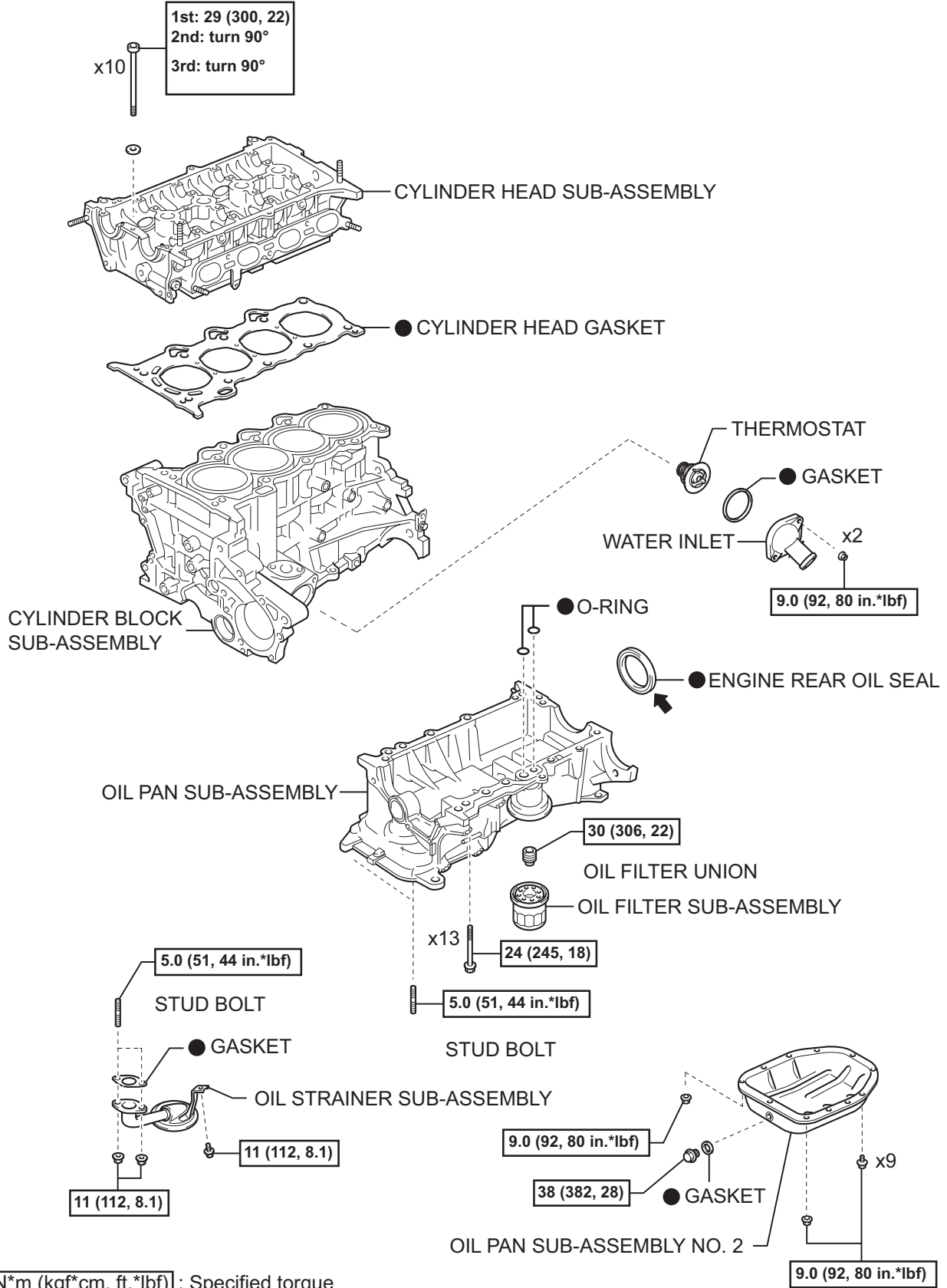

[N*m (kgf*cm, ft.*lbf)] : Specified torque

● Non-reusable part

← Apply MP grease

EM

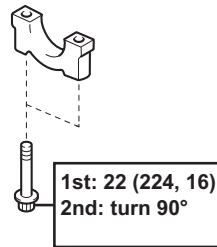
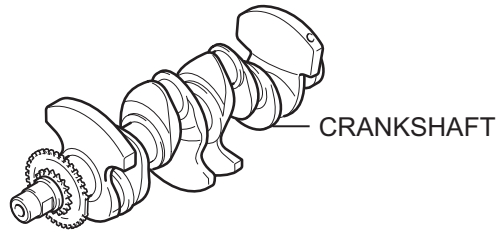
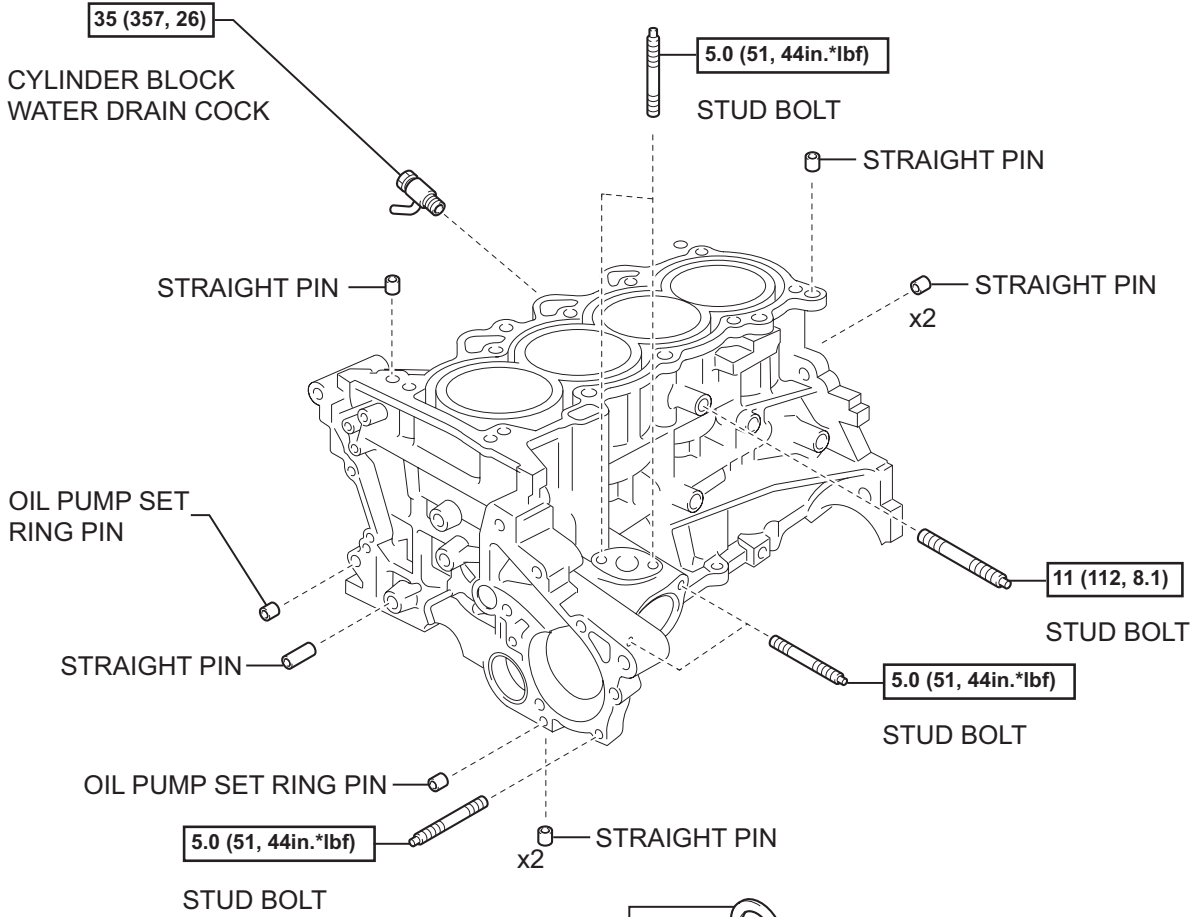

CRANKSHAFT BEARING CAP SET BOLT

N*m (kgf*cm, ft.*lbf) : Specified torque

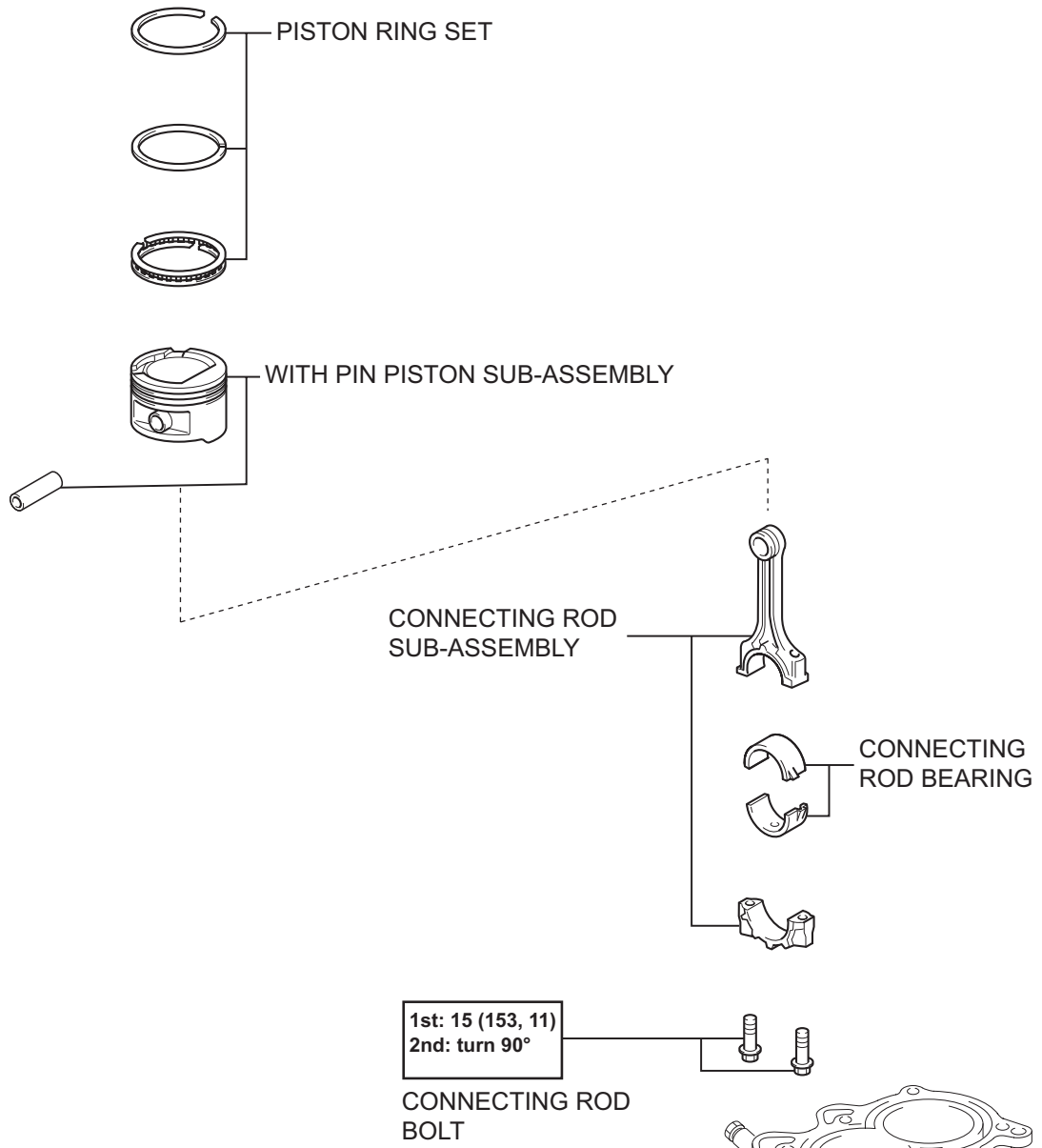

N*m (kgf*cm, ft.*lbf) : Specified torque

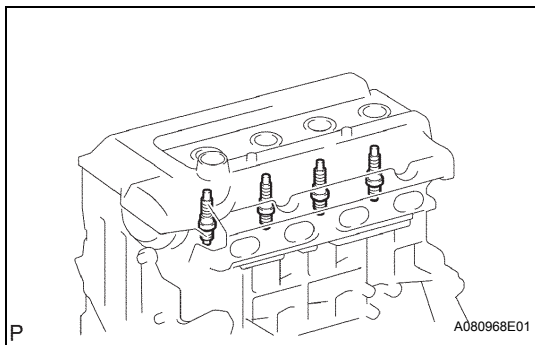
DISASSEMBLY**1. REMOVE SPARK PLUG**

- (a) Using a spark plug wrench, remove the 4 spark plugs.

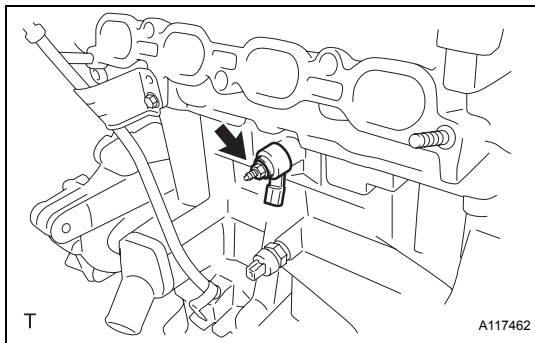
**2. REMOVE KNOCK SENSOR**

- (a) Remove the nut and remove the knock sensor.

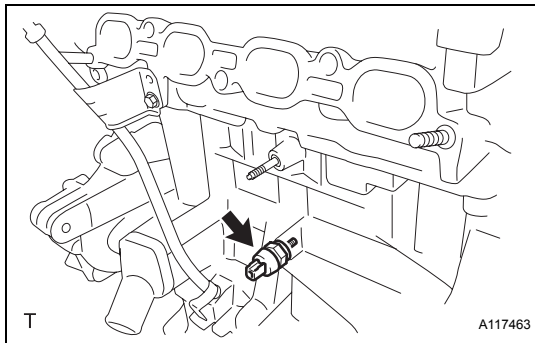
**3. REMOVE ENGINE OIL PRESSURE SWITCH ASSEMBLY**

- (a) Using a 24 mm deep socket wrench, remove the oil pressure switch.

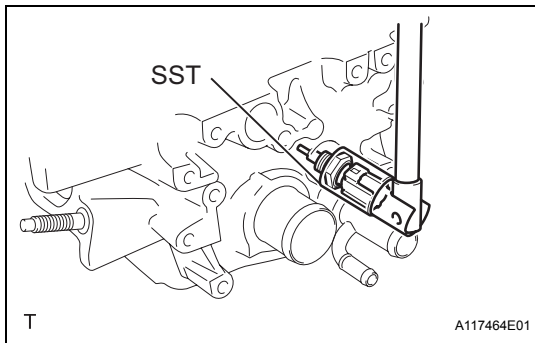
**4. REMOVE ENGINE COOLANT TEMPERATURE SENSOR**

- (a) Using SST, remove the engine coolant temperature sensor.

SST 09817-33190

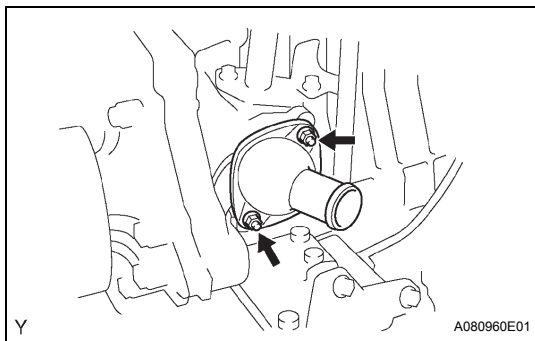
**5. REMOVE WATER INLET**

- (a) Remove the 2 nuts and remove the water inlet.

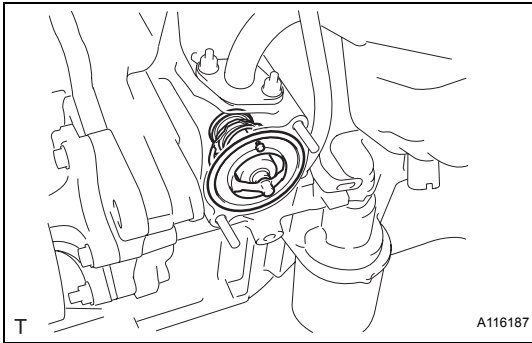
**6. REMOVE THERMOSTAT**

- (a) Remove the thermostat.
- (b) Remove the gasket from the thermostat.

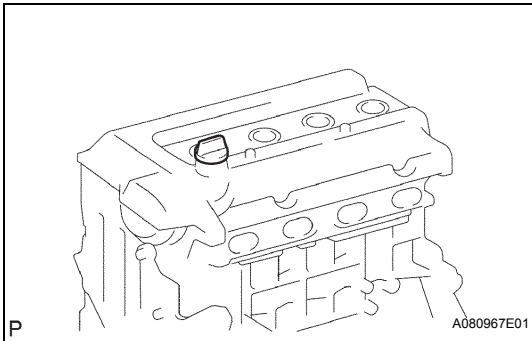
**7. REMOVE OIL FILLER CAP SUB-ASSEMBLY**

- (a) Remove the oil filler cap from the cylinder head cover.

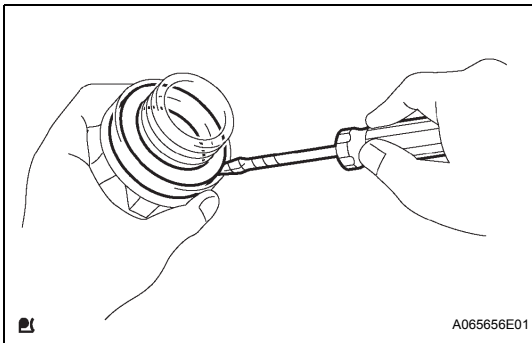
**8. REMOVE OIL FILLER CAP GASKET**

- (a) Using a screwdriver, remove the gasket from the oil filler cap.

9. REMOVE CRANKSHAFT POSITION SENSOR

- (a) Remove the bolt and the crankshaft position sensor.

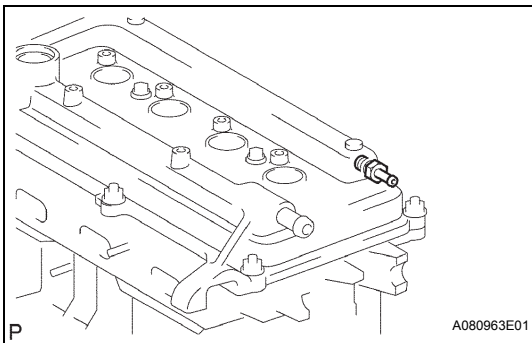
**10. REMOVE VENTILATION VALVE SUB-ASSEMBLY**

- (a) Remove the ventilation valve from the cylinder head cover.

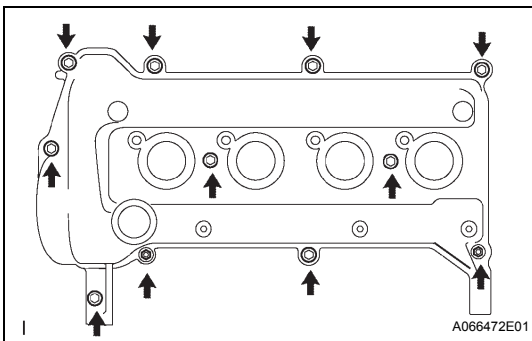
**11. REMOVE CYLINDER HEAD COVER SUB-ASSEMBLY**

- (a) Remove the 9 bolts, 2 nuts and 2 seal washers and then remove the cylinder head cover sub-assembly.

12. REMOVE CYLINDER HEAD COVER GASKET

- (a) Remove the gasket from the cylinder head cover.

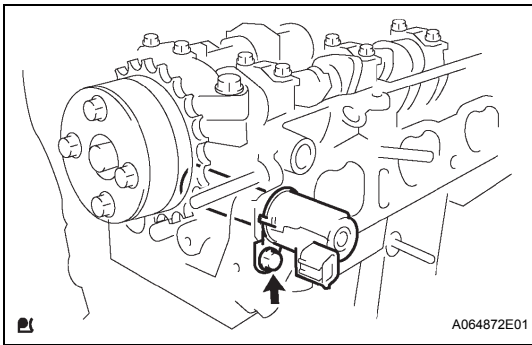

13. REMOVE CAMSHAFT TIMING OIL CONTROL VALVE ASSEMBLY

- (a) Remove the bolt and the camshaft timing oil control valve.

14. REMOVE OIL LEVEL GAUGE GUIDE

- (a) Remove the bolt and the oil level gauge guide.

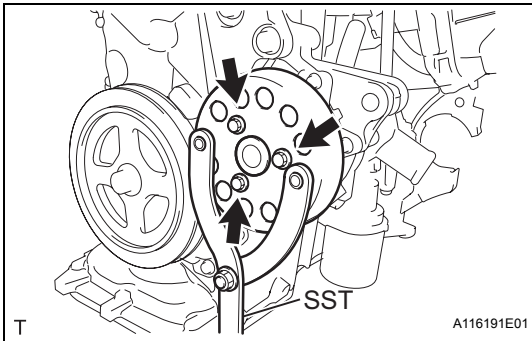

15. REMOVE WATER PUMP PULLEY

- (a) Using SST, hold the pump pulley.
SST 09960-10010 (09962-01000, 09963-00700)
 (b) Remove the 3 bolts and the pump pulley.

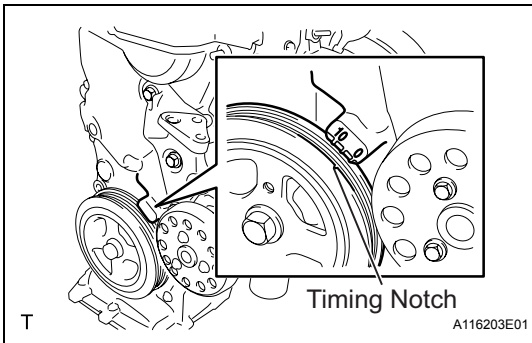

16. REMOVE CRANKSHAFT DAMPER SUB-ASSEMBLY

- (a) Set cylinder No. 1 to TDC/compression.
 (1) Turn the crankshaft damper sub-assembly, and align its timing notch with timing mark "0" of the oil pump.

- (2) Check that the timing marks on the camshaft timing sprocket and the camshaft timing gear are all facing upward, as shown in the illustration.

If not, turn the crankshaft 1 complete revolution (360°) and align the marks as above.

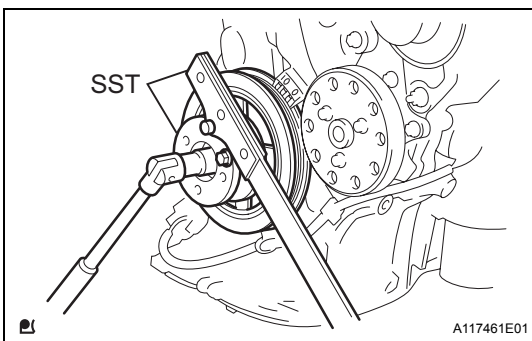
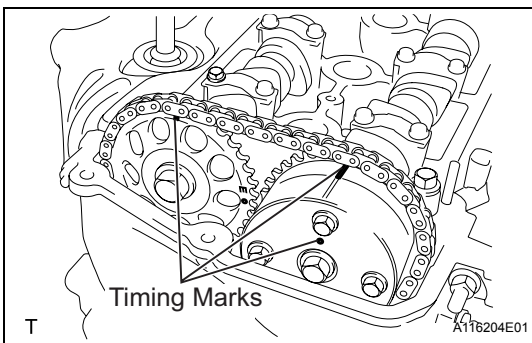

- (b) Using 2 SSTs, loosen the bolt while holding the crankshaft damper sub-assembly.
SST 09213-14010 (91651-60865), 09330-00021

NOTICE:
 Check the SST installation positions when installing them, to avoid the SST fixing bolts from coming into contact with the oil pump assembly.

- (c) Remove the SSTs and the bolt.
 (d) Remove the crankshaft damper sub-assembly.

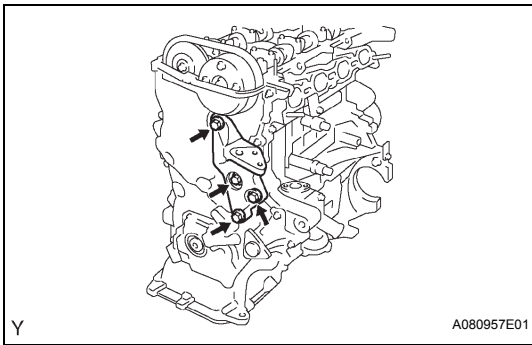

17. REMOVE TRANSVERSE ENGINE ENGINE MOUNTING BRACKET

- (a) Remove the 4 bolts and remove the transverse engine mounting bracket.

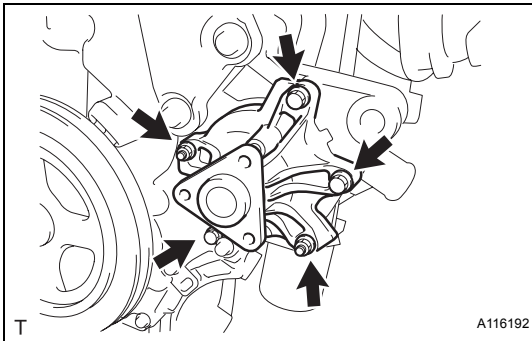

18. REMOVE WATER PUMP ASSEMBLY

- (a) Remove the 3 bolts and the 2 nuts and remove the water pump and the gasket.

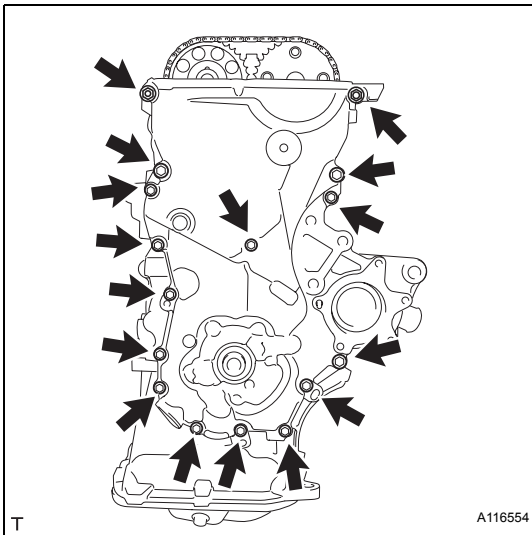

19. REMOVE OIL PUMP ASSEMBLY

- (a) Remove the 15 bolts and the nut.

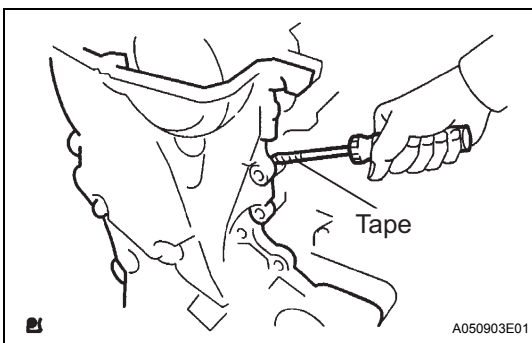

- (b) Using a screwdriver with its tip wrapped in protective tape, prize the oil pump assembly to remove it.

NOTICE:

Do not damage the contact surface of the oil pump assembly and oil pan sub-assembly.

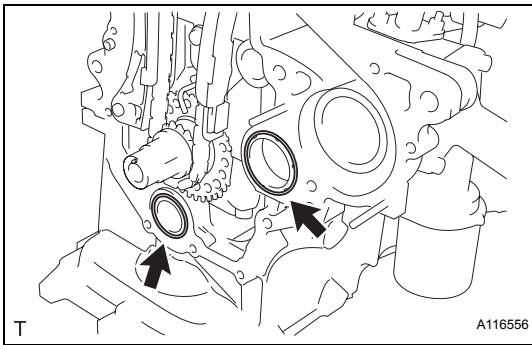

- (c) Remove the 2 O-rings from the cylinder block and oil pan sub-assembly.

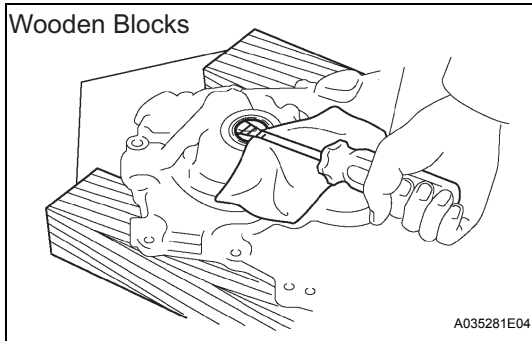

20. REMOVE OIL PUMP SEAL

- (a) Using a screwdriver with its tip wrapped in tape, remove the oil seal.

21. REMOVE CHAIN TENSIONER ASSEMBLY NO. 1

NOTICE:

- Do not rotate the crankshaft with the chain tensioner removed.
- When rotating the camshaft with the timing chain removed, rotate the crankshaft counterclockwise 40° from the TDC first.

- (a) Pull up the stopper plate and hold it with its lock released.

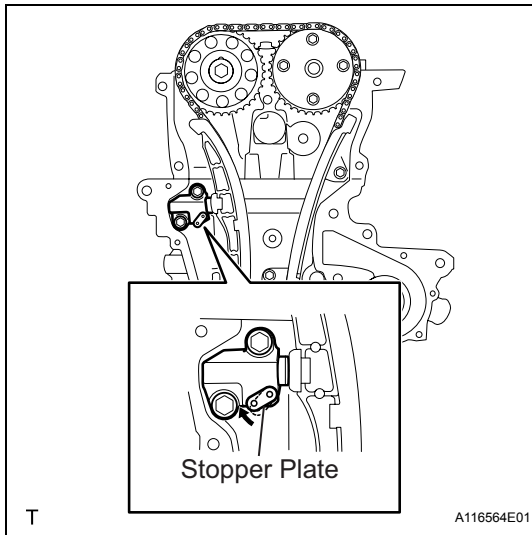

- (b) Unlock the plunger of the tensioner and push it in to the end.

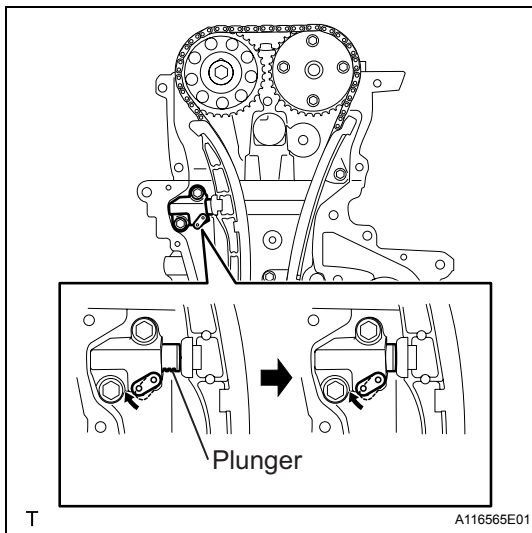

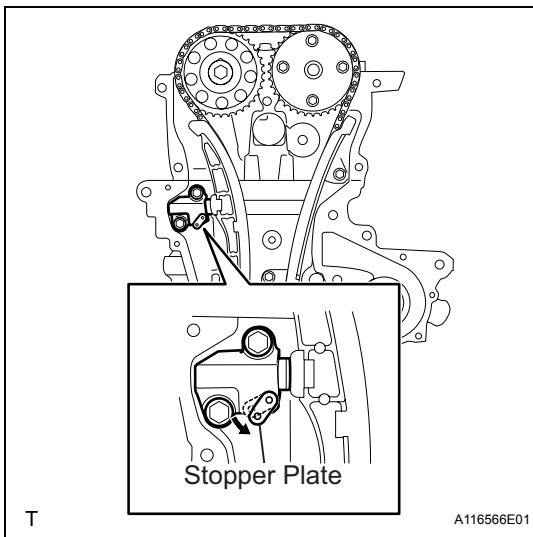

- (c) Pull down the stopper plate with the plunger pushed to the end and lock the plunger.

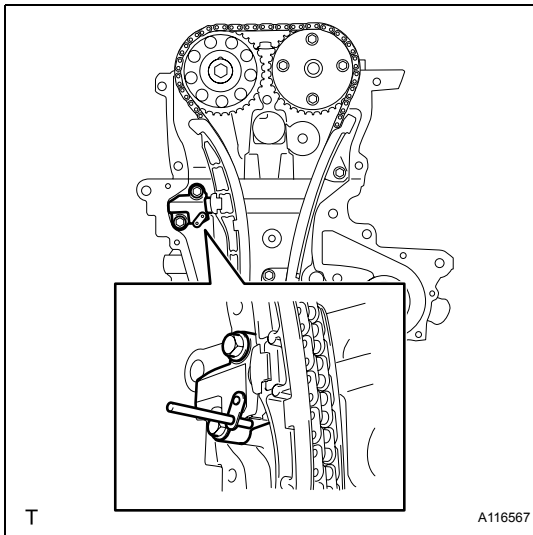

- (d) Insert a 3 mm (0.12 in.) diameter bar into the hole in the stopper plate and lock the plunger.

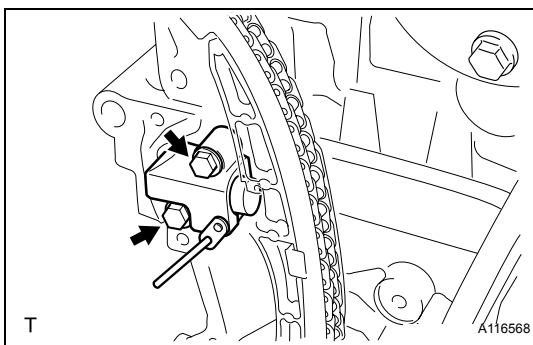

- (e) Remove the 2 bolts and remove chain tensioner assembly No. 1.

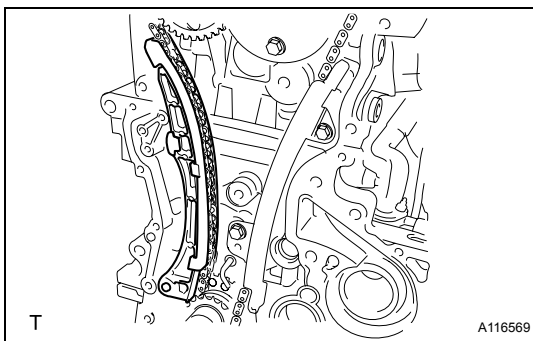

22. REMOVE CHAIN TENSIONER SLIPPER

- (a) Remove the chain tensioner slipper.

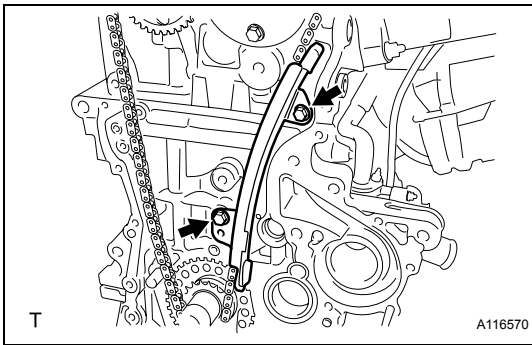
**23. REMOVE CHAIN VIBRATION DAMPER NO. 1**

- (a) Remove the 2 bolts and remove chain vibration damper No. 1.

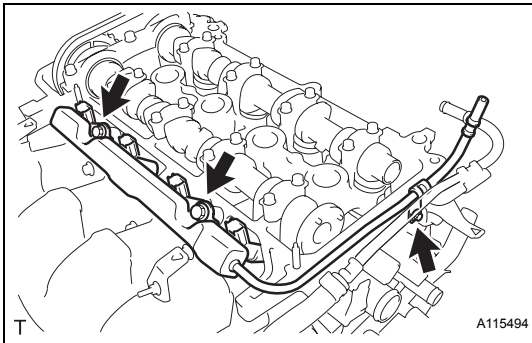
24. REMOVE CHAIN SUB-ASSEMBLY**25. REMOVE FUEL DELIVERY PIPE SUB-ASSEMBLY**

- (a) Remove the 3 bolts and remove the fuel delivery pipe sub-assembly with 4 fuel injectors.

NOTICE:

Do not drop the fuel injectors when removing the fuel delivery pipe sub-assembly.

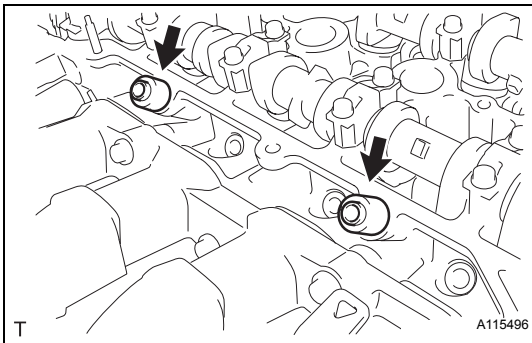
**26. REMOVE DELIVERY PIPE NO. 1 SPACER**

- (a) Remove the 2 delivery pipe No. 1 spacers.

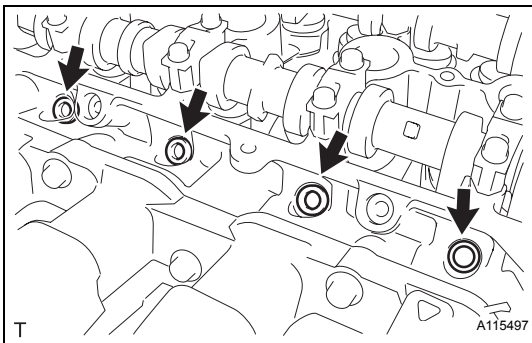
**27. REMOVE INJECTOR VIBRATION INSULATOR**

- (a) Remove the 4 injector vibration insulators.

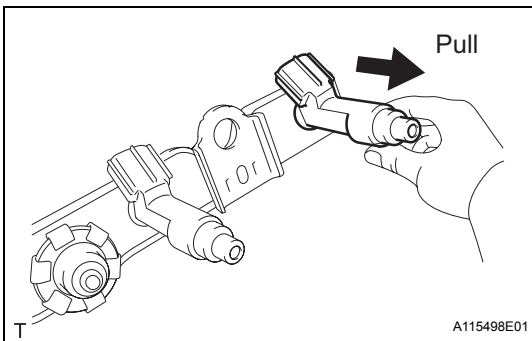
**28. REMOVE FUEL INJECTOR ASSEMBLY**

- (a) Pull the 4 fuel injector assemblies out of the fuel delivery pipe sub-assembly.

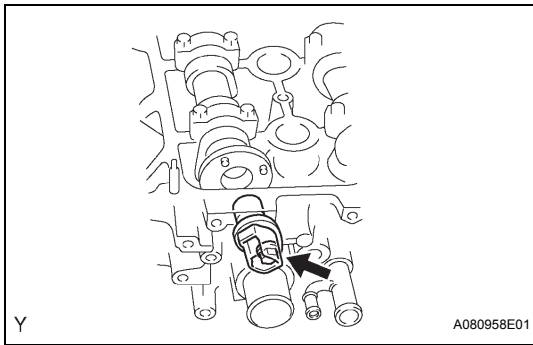
**29. REMOVE CAMSHAFT POSITION SENSOR**

- (a) Remove the bolt and the camshaft position sensor.

30. REMOVE NO. 2 CAMSHAFT**NOTICE:**

When rotating the camshaft with the timing chain removed, rotate the crankshaft counterclockwise 40° from the TDC first.

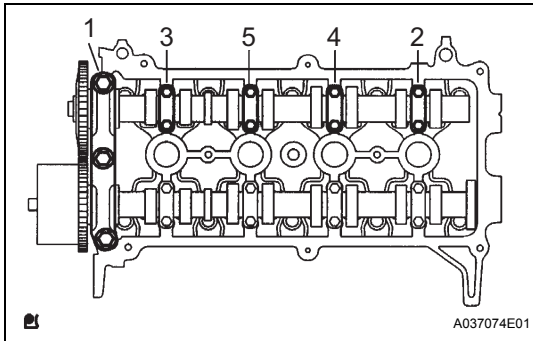

- (a) Using several steps, uniformly loosen and remove the 11 bearing cap bolts in the sequence shown in the illustration, then remove camshaft bearing cap No. 1, camshaft bearing cap No. 2 and camshaft No. 2.

NOTICE:

Loosen each bolt uniformly while keeping the camshaft level.

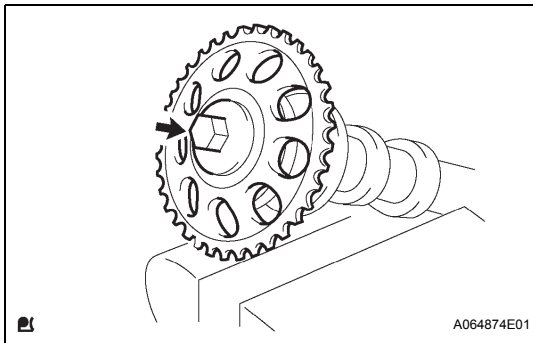
**31. REMOVE CAMSHAFT TIMING SPROCKET**

- (a) Clamp the camshaft in a vice.
 (b) Remove the flange bolt and the camshaft timing sprocket.

NOTICE:

Do not damage the camshaft.

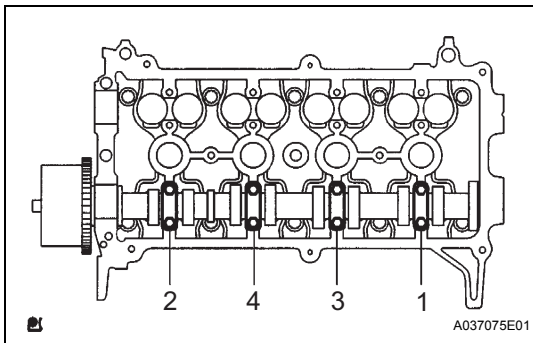
**32. REMOVE CAMSHAFT**

- (a) Using several steps, uniformly loosen and remove the 8 bearing cap bolts in the sequence shown in the illustration, then remove camshaft bearing cap No. 2 and the camshaft.

NOTICE:

Loosen each bolt uniformly while keeping the camshaft level.

33. REMOVE CAMSHAFT TIMING GEAR ASSEMBLY

- (a) Clamp the camshaft in a vise, and confirm that it is locked.

NOTICE:

Do not damage the camshaft.

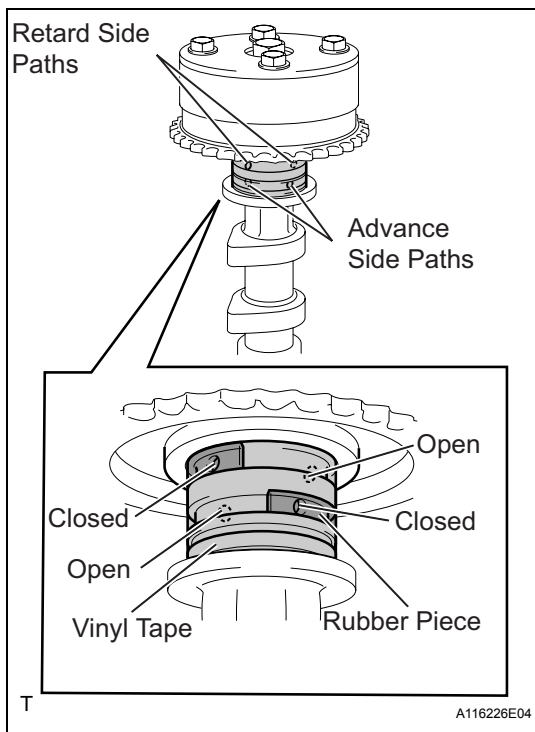

- (b) Cover the 4 oil paths of the cam journal with tape as shown in the illustration.

HINT:

One of the 2 grooves located on the cam journal is for retarding cam timing (upper) and the other is for advancing cam timing (lower). Each groove has 2 oil paths. Plug one of the oil paths for each groove with a piece of rubber before wrapping the cam journal with the tape.

- (c) Puncture the tape covering the advance oil path and the retard oil path on the opposite side from the advance oil path.

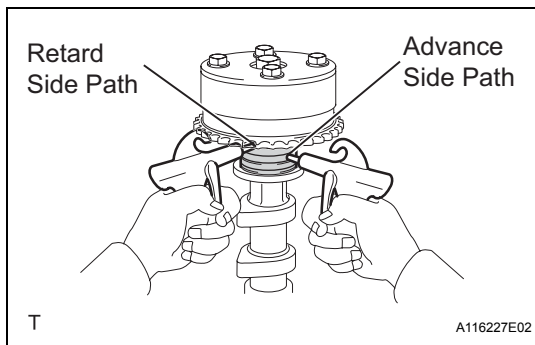

- (d) Apply about 150 kPa (1.5 kgf*cm²) air pressure into the 2 broken paths (the advance side path and the retard side path).

NOTICE:

Cover the paths with a shop rag or piece of cloth to prevent oil splashes.

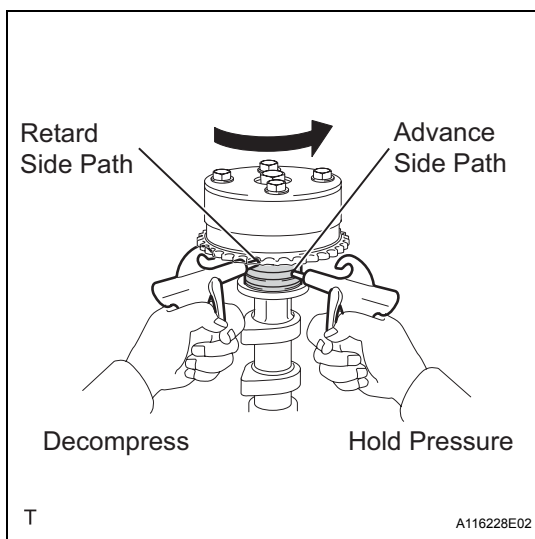

- (e) Confirm that the camshaft timing gear assembly revolves in the timing advance direction when the air pressure on the timing retard path is reduced.

HINT:

The lock pin is released and the camshaft timing gear revolves in the advance direction.

- (f) When the camshaft timing gear reaches the most advanced position, release the air pressure on the timing retard side path, and then release the air pressure on the timing advance side path.

NOTICE:

Camshaft timing gear assembly occasionally shifts to the retard side abruptly if the air pressure on the advance side path is released first. This often results in breakage of the lock pin.

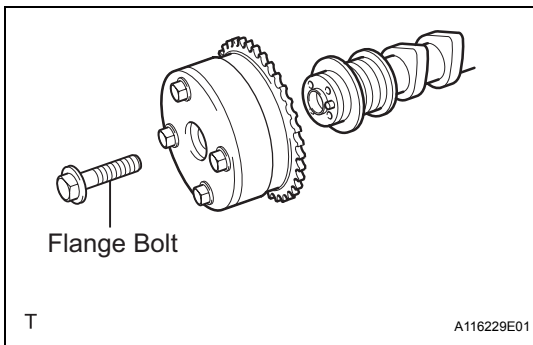

- (g) Remove the flange bolt and remove the camshaft timing gear assembly.

NOTICE:

- Do not remove the other 4 bolts.
- When reusing the camshaft timing gear, unlock the lock pin inside the camshaft timing gear first.

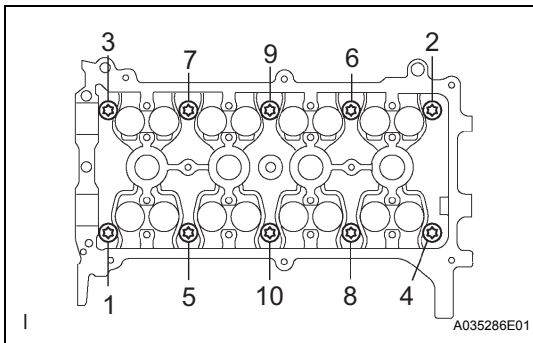
**34. REMOVE CYLINDER HEAD SUB-ASSEMBLY**

- (a) Using several steps, uniformly loosen and remove the 10 cylinder head bolts with an 8 mm bi-hexagon wrench in the sequence shown in the illustration. Remove the 10 cylinder head bolts and the plate washers.

NOTICE:

- Do not drop the washers into the cylinder head.
- Head warpage or cracking could result from removing bolts in the wrong order.

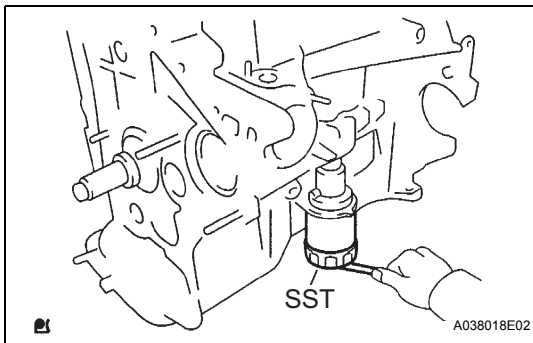
**35. REMOVE CYLINDER HEAD GASKET****36. REMOVE OIL FILTER SUB-ASSEMBLY**

- (a) Using SST, remove the oil filter.

SST 09228-06501

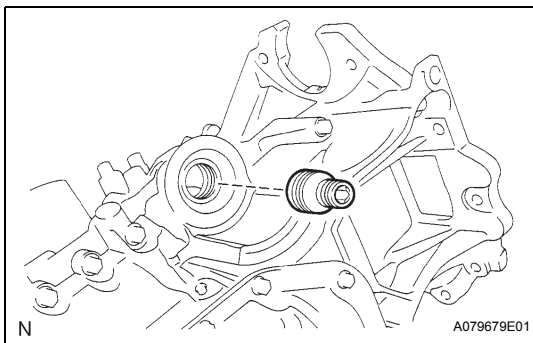
**37. REMOVE OIL FILTER UNION**

- (a) Using a 12 mm hexagon wrench, remove the oil filter union.

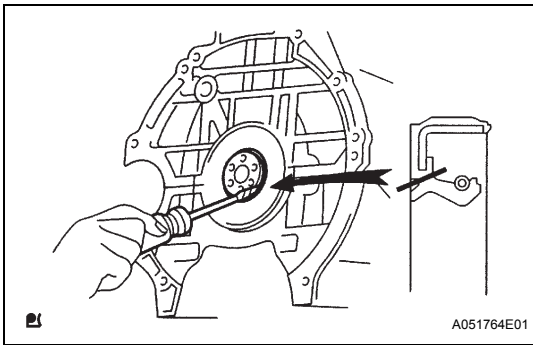
**38. REMOVE ENGINE REAR OIL SEAL**

- (a) Using a knife, cut off the oil seal lip.
- (b) Using a screwdriver with its tip wrapped in protective tape, pry out the oil seal.

NOTICE:

After removal, check the crankshaft for any damage. If damaged, smooth the surface with 400-grit sandpaper.

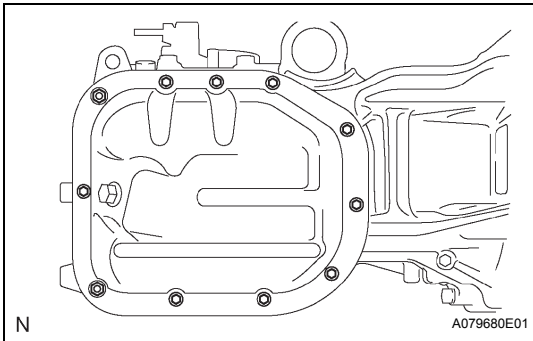
**39. REMOVE OIL PAN SUB-ASSEMBLY NO. 2**

- (a) Remove the oil pan drain plug and gasket.
- (b) Remove the 9 bolts and 2 nuts.

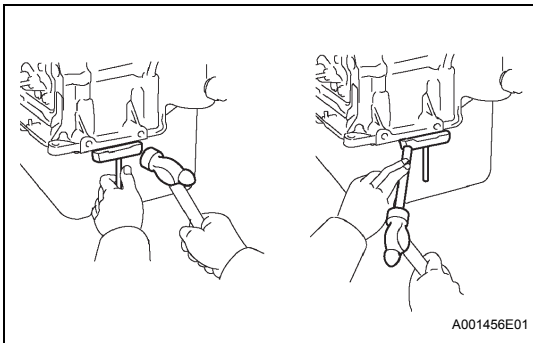

- (c) Insert the blade of SST between oil pan No. 1 and oil pan No. 2, and cut off the applied sealer and remove oil pan No. 2.

SST 09032-00100**NOTICE:**

Do not damage oil pan No. 1 or oil pan No. 2.

40. REMOVE OIL STRAINER SUB-ASSEMBLY

- (a) Remove the bolt and 2 nuts.
- (b) Remove the oil strainer and the gasket.

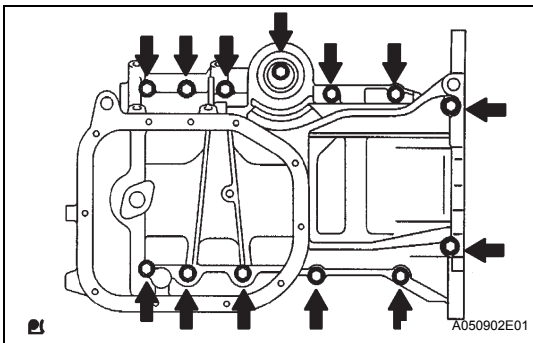
**41. REMOVE OIL PAN SUB-ASSEMBLY**

- (a) Loosen and remove the 13 bolts uniformly in several steps.

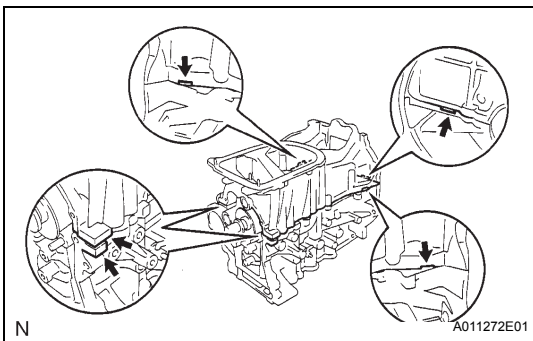

- (b) Using a screwdriver, remove oil pan No. 1 by prying between the cylinder block and oil pan No. 1.

NOTICE:

Do not damage the contact surfaces of oil pan No. 1 or the cylinder block.

- (c) Remove the 2 O-rings from the cylinder block.

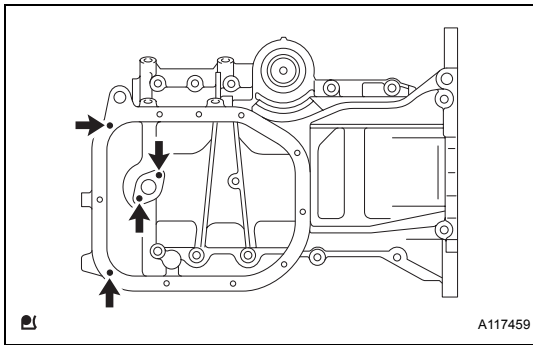
**42. REMOVE STUD BOLT**

- (a) Remove the 4 stud bolts.

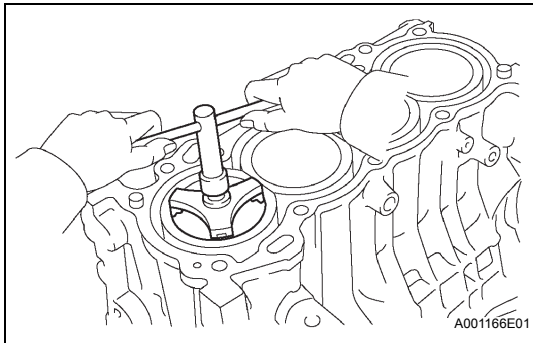
**43. REMOVE PISTON SUB-ASSEMBLY WITH CONNECTING ROD**

- (a) Using a ridge reamer, remove all the carbon from the top of the cylinder.
- (b) Push the piston, connecting rod assembly and upper bearing down through the top of the cylinder block to remove them.

HINT:

- Keep the bearing, connecting rod and cap together.
- Keep the piston and the connecting rod assemblies in the correct order so that they can be returned to their original locations when reassembled.

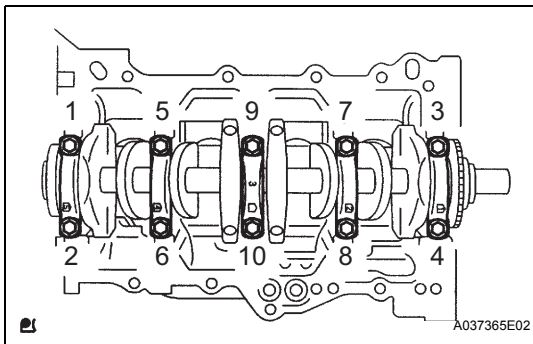
**44. REMOVE CONNECTING ROD BEARING****45. REMOVE CRANKSHAFT**

- (a) Using several steps, loosen and remove the 10 bearing cap sub-assembly bolts uniformly with SST in the sequence shown in the illustration.

SST 09011-38121

- (b) Remove the bearing cap and the crankshaft.

46. REMOVE CRANKSHAFT BEARING**47. REMOVE CRANKSHAFT THRUST WASHER UPPER****48. REMOVE PISTON RING SET****NOTICE:**

Keep the piston rings in the correct combination and correct order so that they can be returned to their original locations when reassembled.

- (a) Using a piston ring expander, remove the 2 compression rings.
- (b) Remove the 2 side rails and the oil ring by hand.

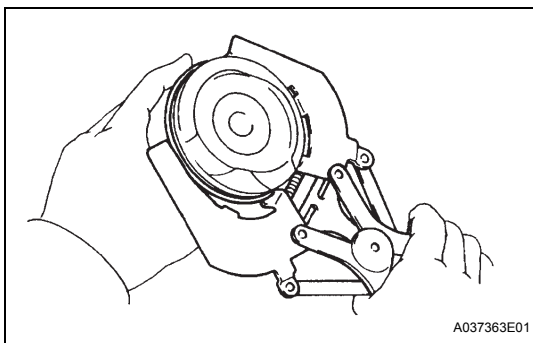

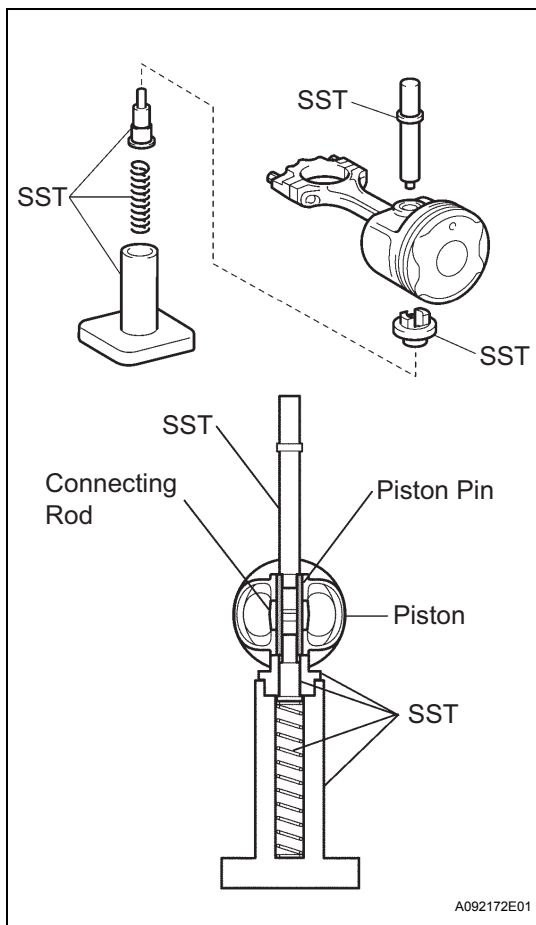
**49. REMOVE WITH PIN PISTON SUB-ASSEMBLY**

- (a) Using SST, press the piston pin out of the piston.
SST 09221-25026 (09221-00021, 09221-00030, 09221-00090, 09221-00150, 09221-00100)

NOTICE:

Keep the pistons, pins, rings, connecting rods and bearings in the correct order so that they can be returned to their original locations when reassembled.

50. REMOVE CYLINDER BLOCK WATER DRAIN COCK SUB-ASSEMBLY**51. REMOVE STUD BOLT**

- (a) Using "Torx" socket wrench E5, remove the 7 stud bolts.

52. REMOVE RING PIN**53. REMOVE STRAIGHT PIN****EM**

INSPECTION

1. INSPECT CAMSHAFT TIMING GEAR ASSEMBLY

- (a) Check the lock of camshaft timing gear.
 (1) Clamp the camshaft in a vice, and check that the camshaft timing gear is locked.

NOTICE:

Do not damage the camshaft.

- (b) Release the lock pin.

- (1) Cover the 4 oil paths of the cam journal with tape as shown in the illustration.

HINT:

One of the 2 grooves located on the cam journal is for retarding cam timing (upper) and the other is for advancing cam timing (lower). Each groove has 2 oil paths. Plug one of the oil paths for each groove with a piece of rubber before wrapping the cam journal with the tape.

- (2) Puncture the tape covering the advance oil path and the retard oil path on the opposite side from the advance oil path.

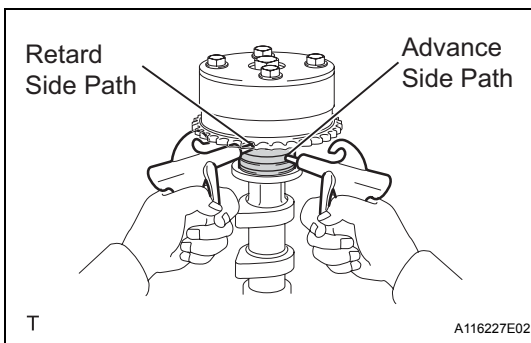
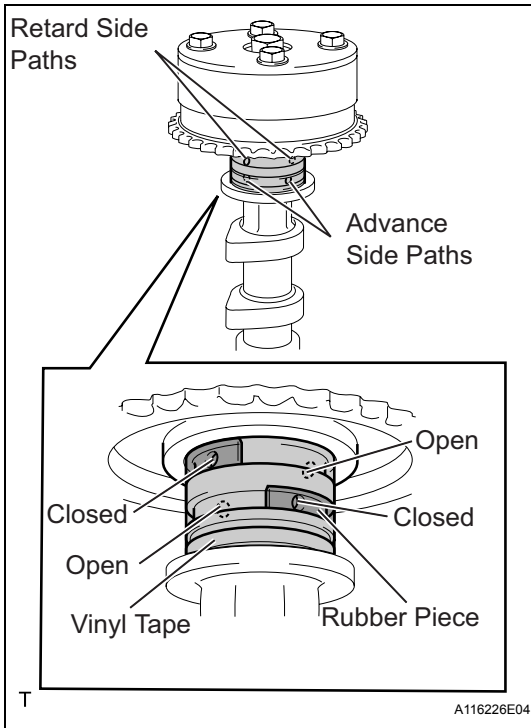

- (3) Apply air at about 150 kPa (1.5 kgf*cm²) pressure into the 2 broken paths (the advance side path and the retard side path).

NOTICE:

Cover the paths with a shop rag or piece of cloth to prevent oil splashes.

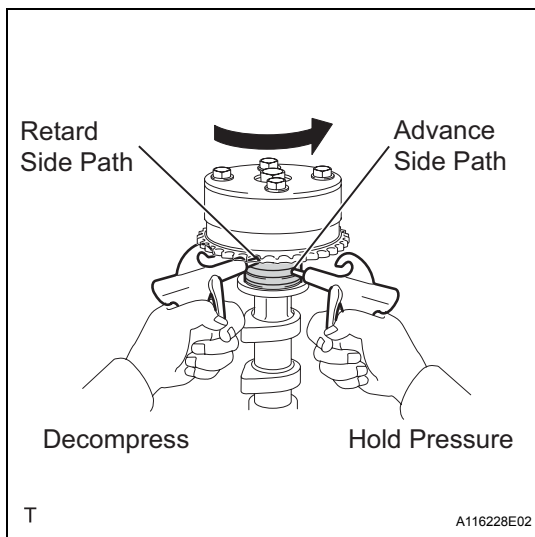

- (4) Confirm that the camshaft timing gear assembly revolves in the timing advance direction when the air pressure on the timing retard path is reduced.

HINT:

The lock pin is released and the camshaft timing gear revolves in the advance direction.

- (5) When the camshaft timing gear reaches the most advanced position, release the air pressure on the timing retard side path, and then release the air pressure on the timing advance side path.

NOTICE:

Camshaft timing gear assembly occasionally shifts to the retard side abruptly if the air pressure on the advance side path is released first. This often results in breakage of the lock pin.

- (c) Check that the revolution is smooth.
- (1) Rotate the valve timing assembly back and forth several times, except where the lock pin meets it at the most retarded angle. Check the movable range and that it rotates smoothly.

Standard:

Smooth movable range is about 22.5°

NOTICE:

Perform this check by hand, instead of using air pressure.

- (d) Check that the gear locks in the most retarded position.

- (1) Confirm that the camshaft timing gear assembly is locked in the most retarded position.

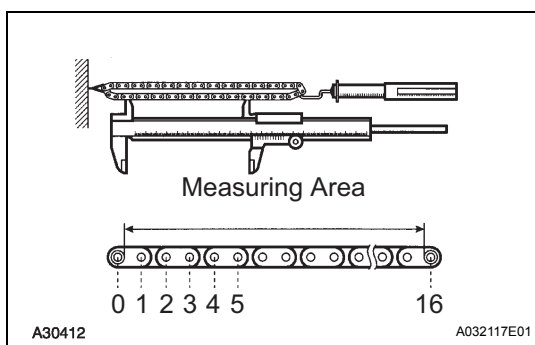

2. INSPECT CHAIN SUB-ASSEMBLY

- (a) Using a spring scale, apply 140 N (14.3 kgf, 31.5 lb) to the timing chain and measure its length.

Maximum chain elongation:

123.2 mm (4.850 in.)

If the elongation is greater than the maximum, replace the chain.

HINT:

Perform the same measurement at 3 or more random places and calculate the average length.

3. INSPECT CHAIN TENSIONER ASSEMBLY NO. 1

- (a) Check that the plunger moves smoothly when the ratchet pawl is raised with your finger.
- (b) Release the ratchet pawl and check that the plunger is locked in place by the ratchet pawl and does not move when pushed with your finger.

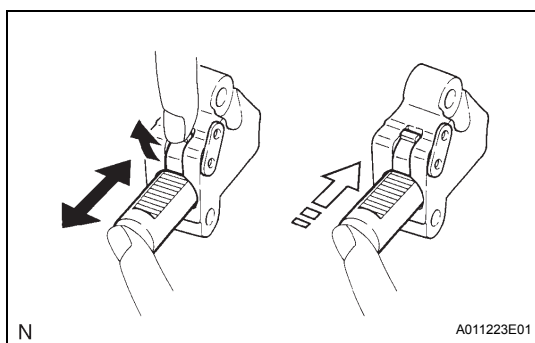

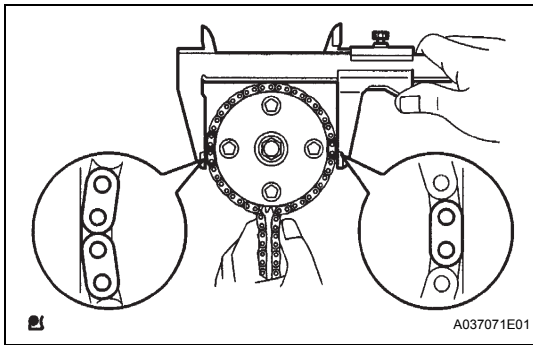

4. INSPECT CAMSHAFT TIMING GEAR ASSEMBLY

- (a) Wrap the chain around the timing sprocket.
- (b) Using vernier calipers, measure the diameter of the timing gear with the chain.

Minimum gear diameter (with chain):

96.2 mm (3.787 in.)

If the diameter is less than the minimum, replace the camshaft timing gear.

NOTICE:

Make sure that the vernier calipers are in contact with the chain link when measuring.

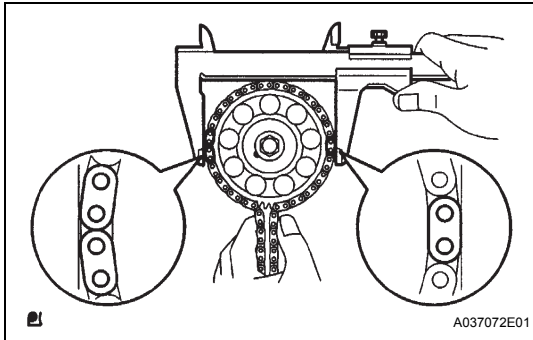

5. INSPECT CAMSHAFT TIMING SPROCKET

- (a) Wrap the chain around the timing sprocket.
- (b) Using vernier calipers, measure the diameter of the timing gear with the chain.

Minimum gear diameter (with chain):

96.2 mm (3.787 in.)

If the diameter is less than the minimum, replace the camshaft timing sprocket.

NOTICE:

Make sure that the vernier calipers are in contact with the chain link when measuring.

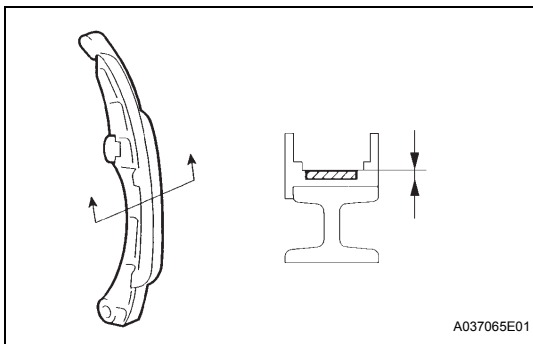

6. INSPECT CHAIN TENSIONER SLIPPER

- (a) Check the chain tensioner slipper.

Minimum thickness:

1.0 mm (0.039 in.)

If the thickness is less than the minimum, replace the chain tensioner slipper.

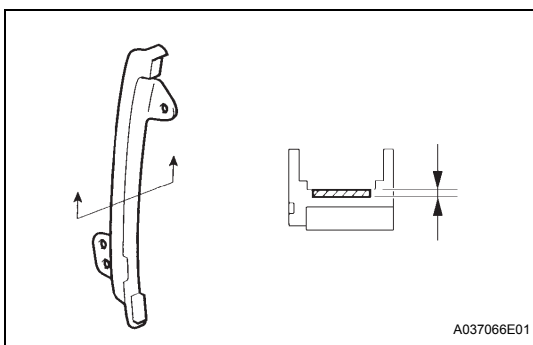

7. INSPECT CHAIN VIBRATION DAMPER NO. 1

- (a) Check the vibration damper.

Minimum thickness:

1.0 mm (0.039 in.)

If the thickness is less than the minimum, replace the chain vibration damper.

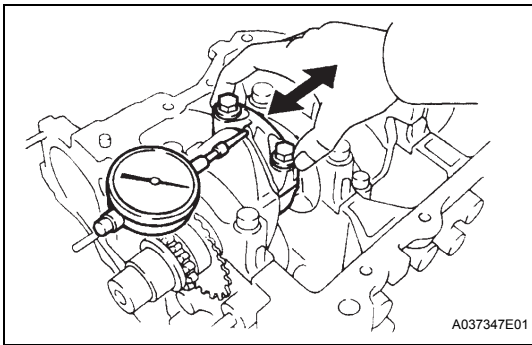

8. INSPECT CONNECTING ROD THRUST CLEARANCE

- (a) Using a dial indicator, measure the thrust clearance while moving the connecting rod back and forth.

Standard thrust clearance:

0.16 to 0.36 mm (0.0063 to 0.0142 in.)

Maximum thrust clearance:

0.36 mm (0.0142 in.)

9. INSPECT CONNECTING ROD OIL CLEARANCE

- (a) Check that the matchmarks on the connecting rod and cap are aligned to ensure correct reassembly.

- (b) Using SST, remove the 2 connecting rod cap bolts.

SST 09205-16010

- (c) Clean the crank pin and bearing.

- (d) Check the crank pin and bearing for pitting and scratches.

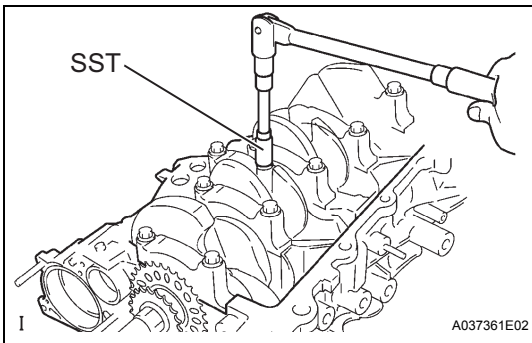

- (e) Lay a strip of Plastigage across the crank pin.

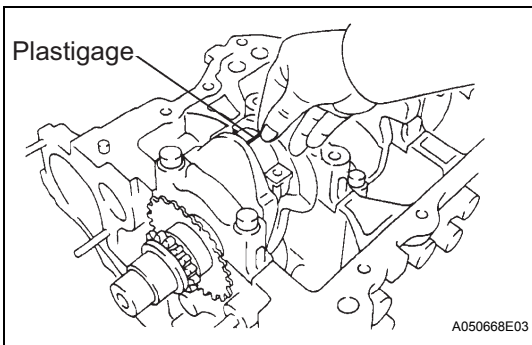

- (f) Make sure that the connecting rod and its cap are in the correct combination and that the front mark of the cap is facing in the correct mounting orientation, then install the cap onto the connecting rod.

- (g) Apply a light coat of engine oil to the threads of the connecting rod cap bolts.

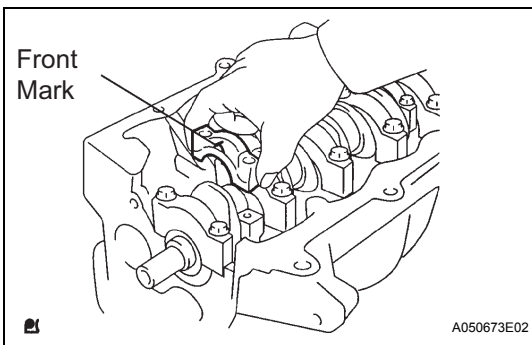

- (h) Using SST, tighten the bolts in several steps to the specified torque.

SST 09205-16010

Torque: 15 N*m (153 kgf*cm, 11 ft.*lbf)

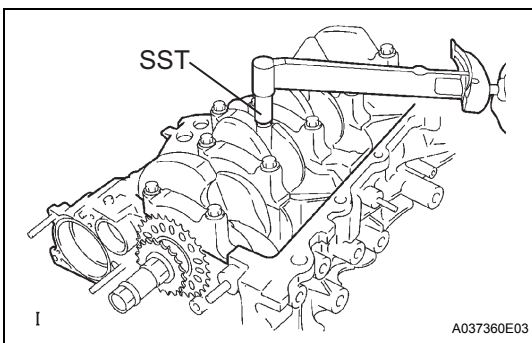

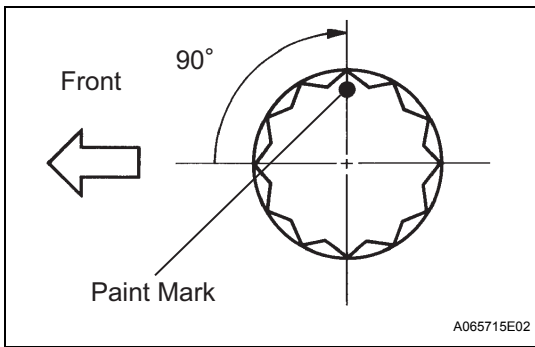

- (i) Mark the front of the connecting cap bolts with paint.
- (j) Retighten the cap bolts by 90° as shown in the illustration.

NOTICE:
Do not turn the crankshaft.

- (k) Remove the 2 bolts, connecting rod cap and lower bearing.

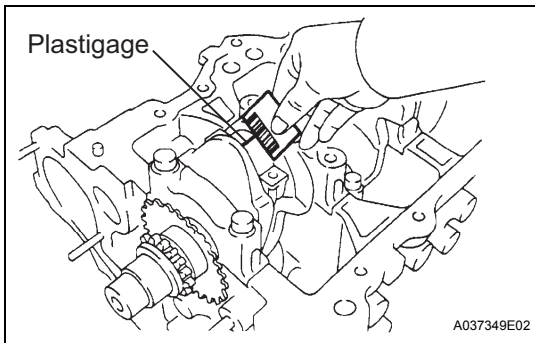

- (l) Measure the Plastigage at its widest point.

Standard oil clearance:

0.012 to 0.038 mm (0.00047 to 0.0015 in.)

Maximum oil clearance:

0.058 mm (0.0028in.)

NOTICE:

Completely remove the Plastigage after the measurement.

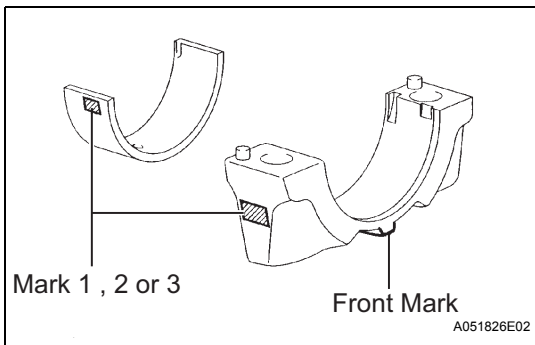

- (m) When replacing a bearing, replace it with one with the same number as marked on the connecting rod. There are 3 sizes of standard bearings, marked 1, 2 and 3 accordingly.

Standard bearing center wall thickness

Mark	mm (in.)
1	1.491 to 1.494 (0.0587 to 0.0588)
2	1.494 to 1.497 (0.0588 to 0.0589)
3	1.497 to 1.500 (0.0589 to 0.0591)

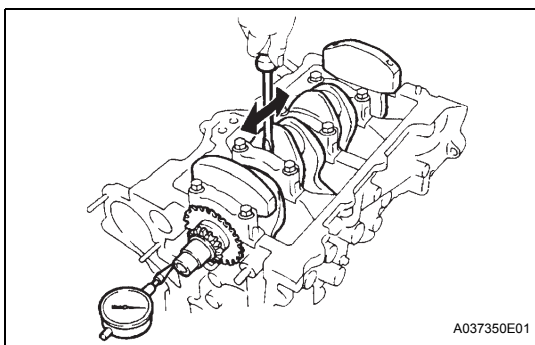

10. INSPECT CRANKSHAFT THRUST CLEARANCE

- (a) Using a dial indicator, measure the thrust clearance while moving the crankshaft back and forth with a screwdriver.

Standard thrust clearance:

0.09 to 0.19 mm (0.0035 to 0.0075 in.)

Maximum thrust clearance:

0.30 mm (0.0118 in.)

If the thrust clearance is greater than the maximum, replace the thrust washers as a set. Check the crankshaft and block for wear. Repair or replace the parts if necessary.

HINT:

Thrust washer thickness: 2.43 to 2.48 mm (0.0957 to 0.976 in.)

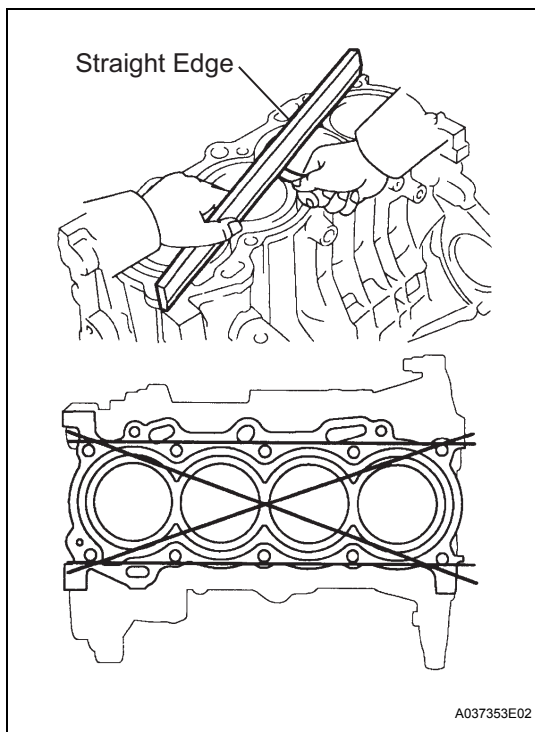

11. INSPECT CYLINDER BLOCK FOR WARPAGE

- (a) Using a precision straight edge and feeler gauge, measure the warpage of the surface which is in contact with the cylinder head gasket.

Maximum warpage:

0.05 mm (0.0020 in.)

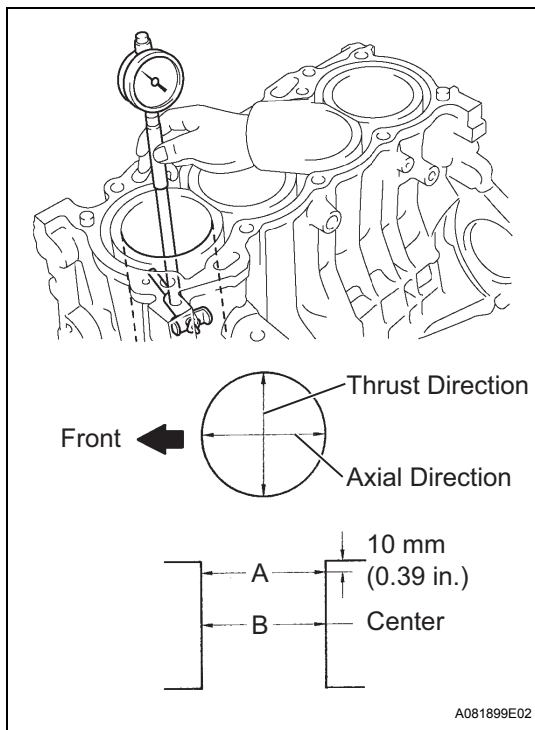

12. INSPECT CYLINDER BORE

- (a) Using a cylinder gauge, measure the cylinder bore diameter at positions A and B in both the thrust and axial directions.

Standard Inside diameter:

75.000 to 75.013 mm (2.9528 to 2.9533 in.)

- (b) Calculate the difference between the maximum diameter and the minimum diameter of the 4 measured values.

Difference limit:

0.10 mm (0.0039 in.)

If the difference is greater than the limit, replace the cylinder block.

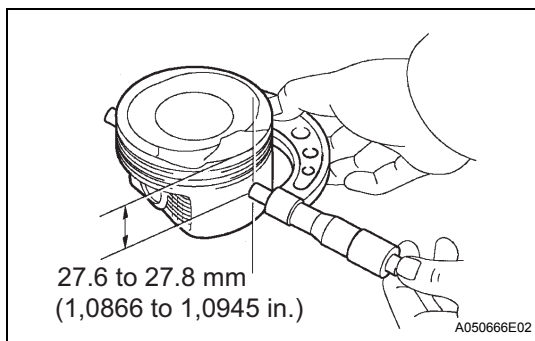

13. INSPECT WITH PIN PISTON SUB-ASSEMBLY

- (a) Using a micrometer, measure the piston diameter at a right angle to the piston pin center line, and at the position 27.6 to 27.8 mm (1.0866 to 1.0945 in.) from the top of the piston head.

Piston diameter:

74.935 to 74.945 mm (2.9502 to 2.9506 in.)

- (b) Using a caliper gauge, measure the piston pin hole diameter.

Piston pin hole diameter:

18.013 to 18.016 mm (0.7092 to 0.7093 in.) at 20°C (68°F)

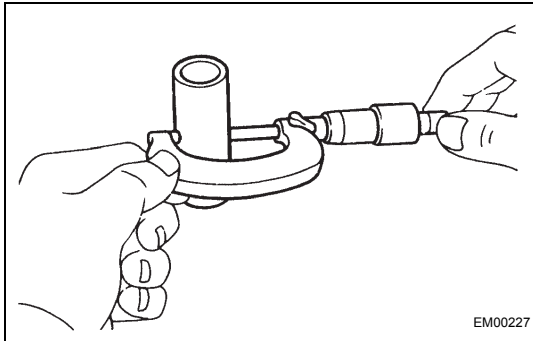

EM00227

- (c) Using a micrometer, measure the piston pin diameter.

Piston pin diameter:

18.001 to 18.004 mm (0.7087 to 0.7088 in.)

- (d) Subtract the piston pin diameter measurement from the piston pin hole diameter measurement to calculate the oil clearance.

Standard oil clearance:

0.009 to 0.015 mm (0.0004 to 0.0006 in.)

Maximum oil clearance:

0.050 mm (0.0020 in.)

If necessary, replace the piston and piston pin together.

EM

14. INSPECT PISTON CLEARANCE

- (a) Subtract the piston diameter measurement from the cylinder bore diameter measurement.

Standard oil clearance:

0.045 to 0.068 mm (0.0018 to 0.0027 in.)

Maximum oil clearance:

0.08 mm (0.0032 in.)

15. INSPECT CONNECTING ROD SUB-ASSEMBLY

- (a) Using a rod aligner and feeler gauge, check the connecting rod alignment.

- (1) Check for misalignment.

Maximum misalignment:

0.05 mm (0.0020 in.) per 100 mm (3.94 in.)

If the misalignment is greater than the maximum, replace the connecting rod assembly.

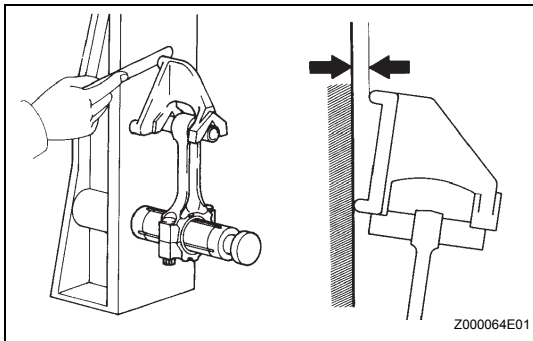

Z000064E01

- (2) Check for twist.

Maximum twist:

0.05 mm (0.0020 in.) per 100 mm (3.94 in.)

If the twist is greater than the maximum, replace the connecting rod assembly.

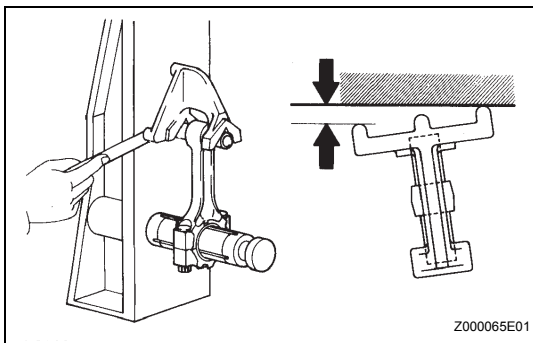

Z000065E01

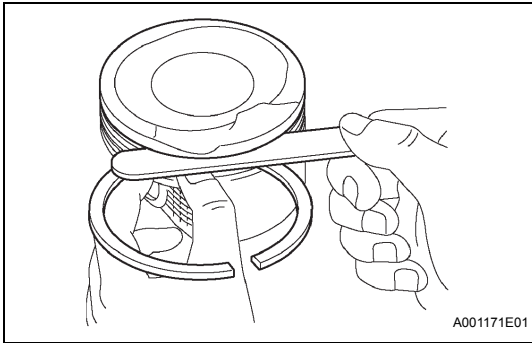
**16. INSPECT RING GROOVE CLEARANCE**

- (a) Using a feeler gauge, measure the clearance between a new piston ring and the wall of the ring groove.

Ring groove clearance:

No. 1:

0.03 to 0.07 mm (0.0012 to 0.0028 in.)

No. 2:

0.02 to 0.06 mm (0.0008 to 0.0024 in.)

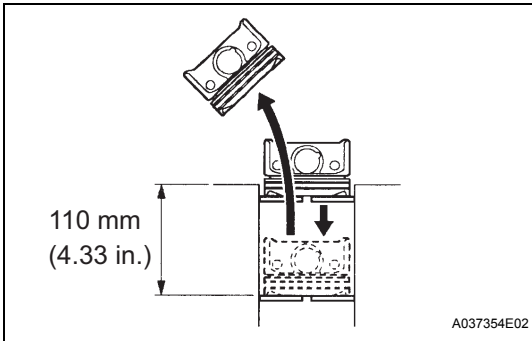
**17. INSPECT PISTON RING END GAP**

- (a) Using a piston, push the piston ring, a little beyond the bottom of the ring travel, 110 mm (4.33 in.) from the top of the cylinder block.

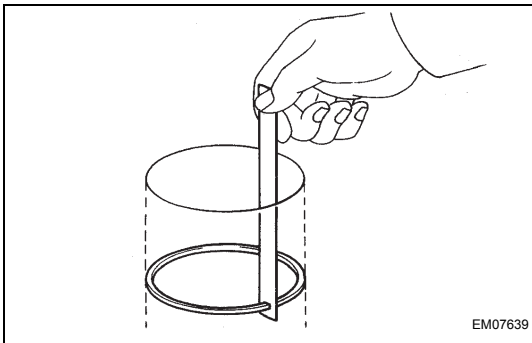

- (b) Using a feeler gauge, measure the end gap.

Standard end gap:

No. 1:

0.25 to 0.35 mm (0.0098 to 0.0138 in.)

No. 2:

0.35 to 0.50 mm (0.0138 to 0.0197 in.)

Oil (Side Rail):

0.10 to 0.35 mm (0.0039 to 0.0138 in.)

Maximum end gap:

No. 1:

0.91 mm (0.0358 in.)

No. 2:

1.06 mm (0.0417 in.)

Oil (Side Rail):

0.82 mm (0.323 in.)

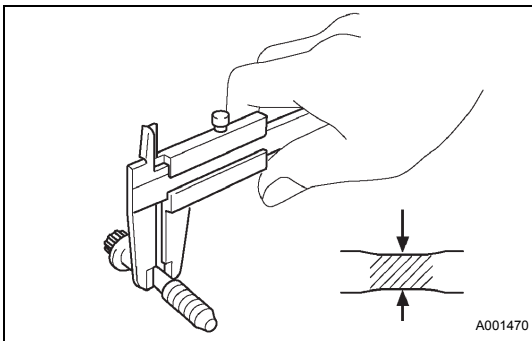
**18. INSPECT CONNECTING ROD BOLT**

- (a) Using vernier calipers, measure the diameter of the bolt at the elongated portion.

Standard diameter:

6.6 to 6.7 mm (0.260 to 0.264 in.)

Minimum diameter:

6.4 mm (0.252 in.)

If the diameter is less than the minimum, replace the bolt.

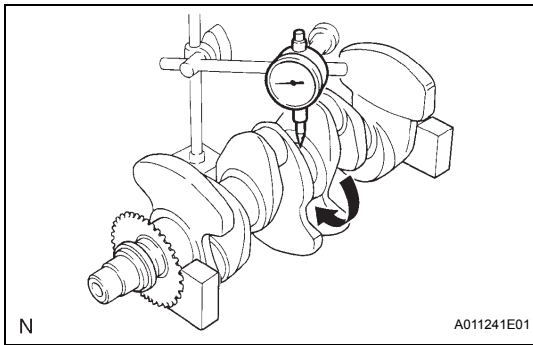

19. INSPECT CRANKSHAFT

- (a) Using a dial indicator and V-blocks, measure the circle runout as shown in the illustration.

**Maximum circle runout:
0.03 mm (0.0012 in.)**

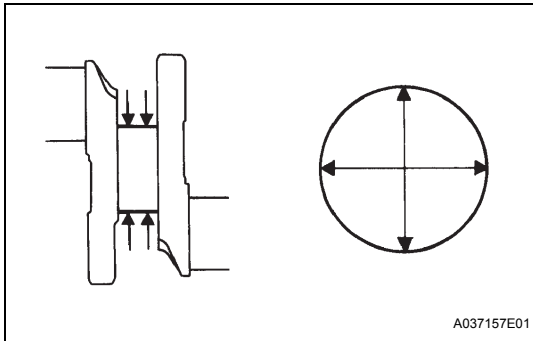

- (b) Using a micrometer, measure the diameter of each main journal.

**Outside diameter:
45.988 to 46.000 mm (1.8106 to 1.8110 in.)**

- (c) Check each main journal for taper and out-of-roundness as shown.

**Maximum taper and out-of-roundness:
0.02 mm (0.0008 in.)**

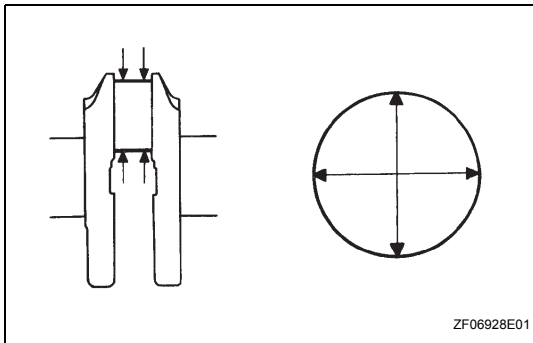

- (d) Using a micrometer, measure the diameter of each crank pin.

**Outside diameter:
39.992 to 40.000 mm (1.5745 to 1.5748 in.)**

- (e) Check each crank pin for taper and out-of-roundness as shown.

**Maximum taper and out-of-roundness:
0.02 mm (0.0008 in.)**

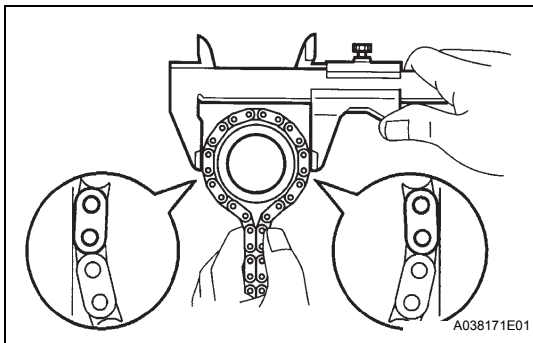

- (f) Wrap the chain around the timing sprocket.
(g) Using vernier calipers, measure the timing sprocket diameter with the chain.

Standard sprocket diameter (with chain):

51.72 mm (2.0362 in.)

Minimum sprocket diameter (with chain):

50.5 mm (1.988 in.)

NOTICE:

Make sure that the vernier calipers are in contact with the chain rollers when measuring.

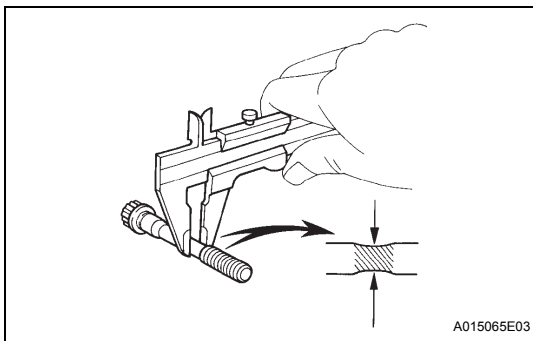

20. INSPECT CRANKSHAFT BEARING CAP SET BOLT

- (a) Using vernier calipers, measure the tension portion diameter of the elongated portion.

Standard diameter:

7.3 to 7.5 mm (0.287 to 0.295 in.)

Minimum diameter:

7.2 mm (0.283 in.)

If the diameter is less than the minimum, replace the bolt.

21. INSPECT CRANKSHAFT OIL CLEARANCE

- (a) Clean each main journal and bearing.
- (b) Install the bearing onto the cylinder block and bearing cap. (See page EM-183)
- (c) Place the crankshaft onto the cylinder block.
- (d) Lay a strip of Plastigage across each journal.

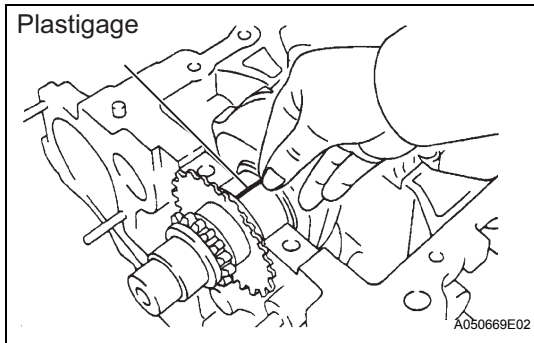

**Bearing
Cap No. 3:**

**Bearing Cap
No. 1, 2, 4, 5:**

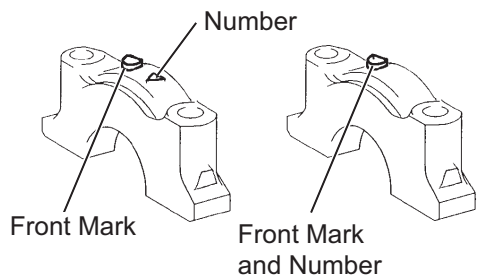

- (e) Examine the front marks and numbers and install the bearing cap onto the cylinder block.
- (f) Apply a light coat of engine oil to the threads of the bearing cap bolts.

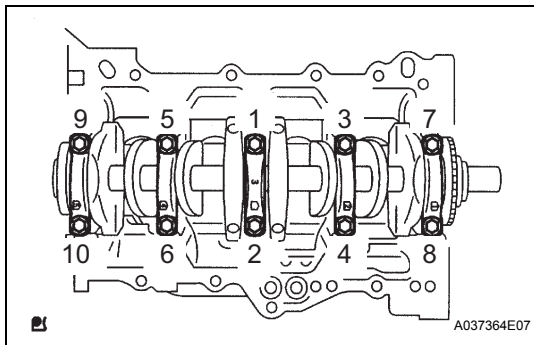

- (g) Using SST, tighten the bolts in several steps to the specified torque in the sequence shown in the illustration. (*1)

SST 09011-38121

Torque: 22 N*m (224 kgf*cm, 16 ft.*lbf)

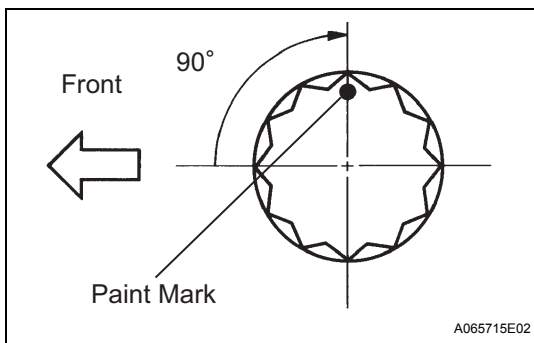

- (h) Mark the front of the bearing cap bolts with paint.
- (i) Retighten the bearing cap bolts by 90° in the same sequence as step (*1).
- (j) Check that the painted mark is now at a 90° angle from the front.

NOTICE:

Do not turn the crankshaft.

- (k) Remove the bearing cap sub-assembly.

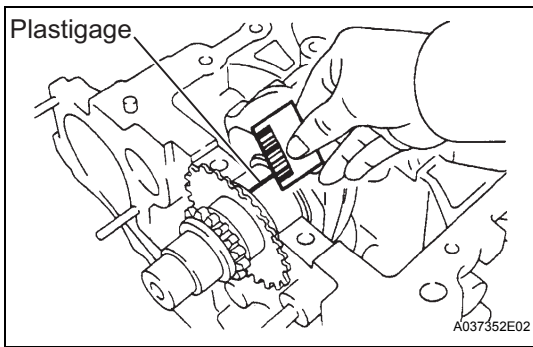

- (l) Measure the Plastigage at its widest point.
Standard oil clearance:
 0.01 to 0.023 mm (0.0004 to 0.0009 in.)
Maximum oil clearance:
 0.07 mm (0.0028 in.)

NOTICE:
Completely remove the Plastigage after the measurement.

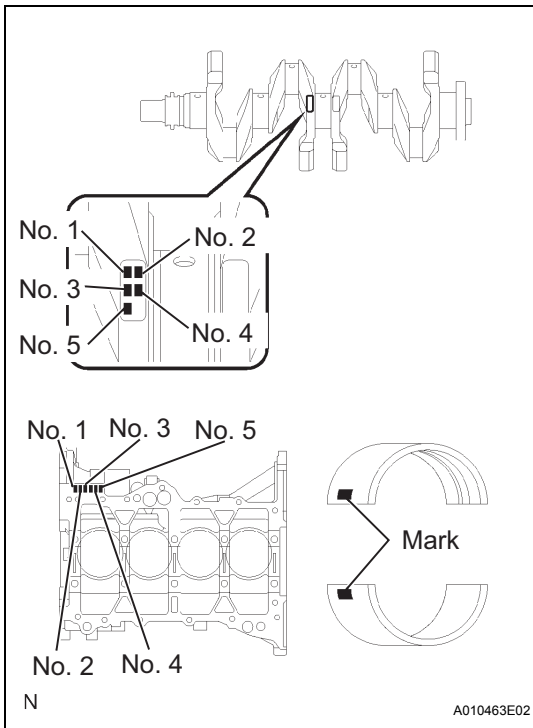

- (m) When replacing a standard bearing, replace it with one with the same number. If the number of the bearing cannot be found, select the correct bearing by adding together the numbers imprinted on the cylinder block and crankshaft, then select the bearing with the same number as the total. There are 4 sizes of standard bearings, marked 1, 2, 3 and 4 accordingly.

EXAMPLE: Cylinder Block 4 (A) + Crankshaft 3 (B) = Total 7 (Use Bearing 3)

Cylinder Block (A) +	0 to 2	3 to 5	6 to 8	9 to 11
Crankshaft (B)				
Use Bearing	1	2	3	4

Item	Mark	mm (in.)
Cylinder block main journal bore diameter (A)	0	50.000 to 50.003 (1.96850 to 1.96862)
	1	50.003 to 50.005 (1.96862 to 1.96870)
	2	50.005 to 50.007 (1.96870 to 1.96878)
	3	50.007 to 50.010 (1.96878 to 1.96890)
	4	50.010 to 50.012 (1.96890 to 1.96898)
	5	50.012 to 50.014 (1.96898 to 1.96906)
	6	50.014 to 50.016 (1.96906 to 1.96913)
Crankshaft main journal diameter (B)	0	45.998 to 46.000 (1.81094 to 1.81102)
	1	45.996 to 45.998 (1.81087 to 1.81094)
	2	45.994 to 45.996 (1.81079 to 1.81087)
	3	45.992 to 45.994 (1.81071 to 1.81079)
	4	45.990 to 45.992 (1.81063 to 1.81071)
	5	45.988 to 45.990 (1.81055 to 1.81063)
Standard bearing center wall thickness	1	1.992 to 1.995 (0.07843 to 0.07854)
	2	1.995 to 1.998 (0.07854 to 0.07866)
	3	1.998 to 2.001 (0.07866 to 0.07878)
	4	2.001 to 2.004 (0.07878 to 0.07890)

REASSEMBLY

1. INSTALL CYLINDER BLOCK WATER DRAIN COCK SUB-ASSEMBLY

- Apply adhesive to the end 2 or 3 threads of the drain union and install the water drain cock within 3 minutes of applying the adhesive.
- After applying the specified torque, rotate the drain union clockwise until its drain port faces downward.
Torque: 35 N*m (357 kgf*cm, 26 ft.*lbf)

NOTICE:

- Do not add coolant within 1 hour of installation.
- Do not rotate the drain union more than 360° in step (b), and never loosen it after setting the union correctly.

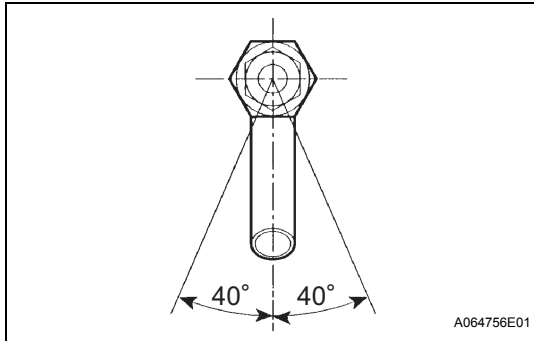

2. INSTALL STRAIGHT PIN

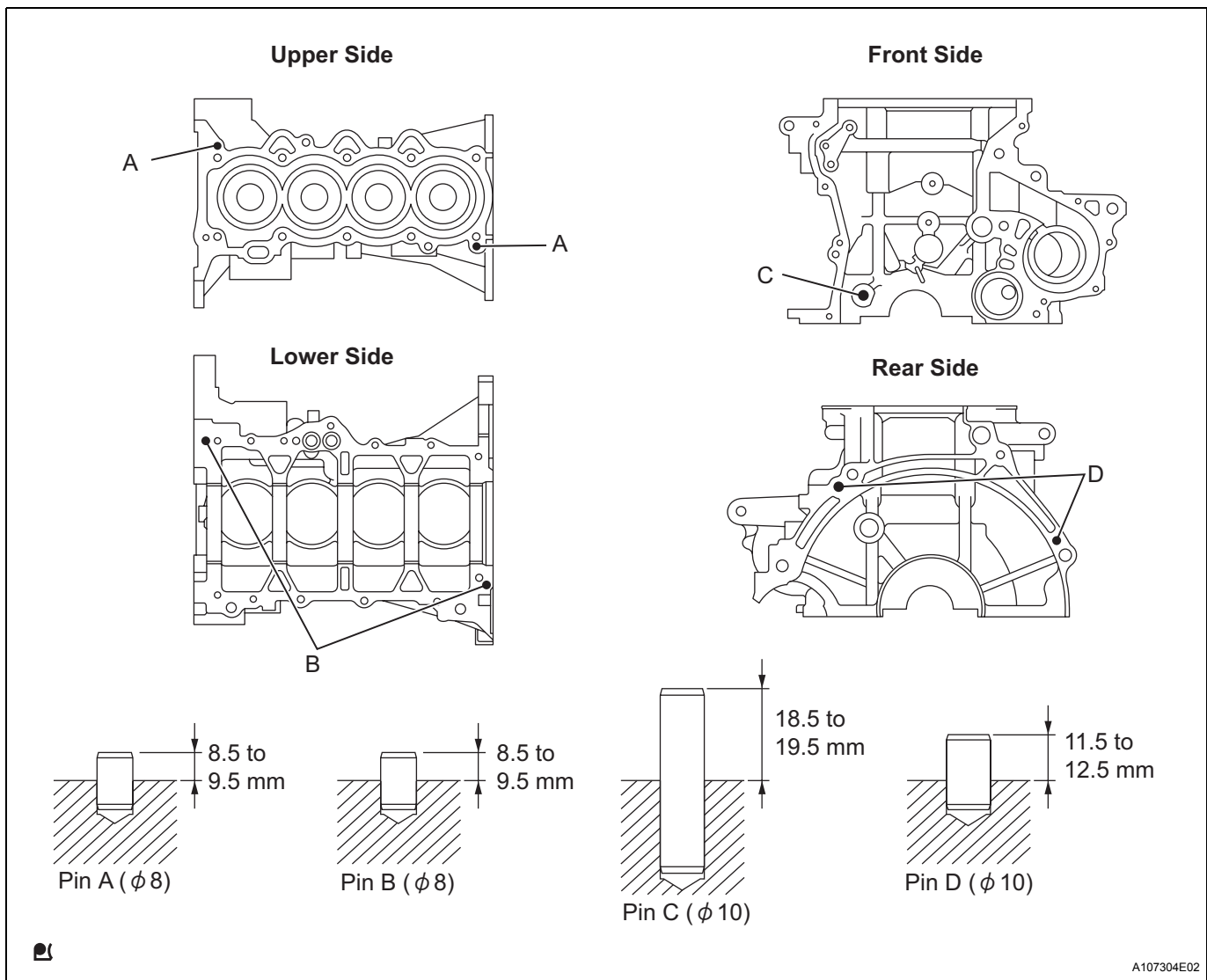

- Using a plastic-faced hammer, tap in the straight pin.

Standard protrusion:

Pin A:

8.5 to 9.5 mm (0.335 to 0.374 in.)

Pin B:

8.5 to 9.5 mm (0.335 to 0.374 in.)

Pin C:

18.5 to 19.5 mm (0.728 to 0.768 in.)

Pin D:

11.5 to 12.5 mm (0.453 to 0.492 in.)

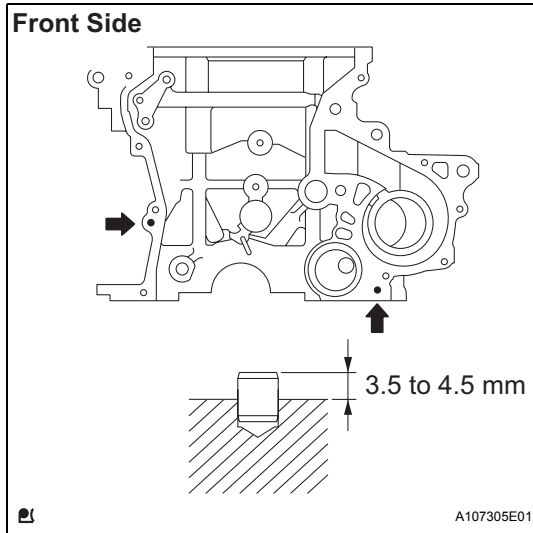

3. INSTALL OIL PUMP SET RING PIN

- (a) Using a plastic-faced hammer, tap in a new ring pin.

Standard protrusion:

3.5 to 4.5 mm (0.138 to 0.177 in.)

4. INSTALL STUD BOLT

EM

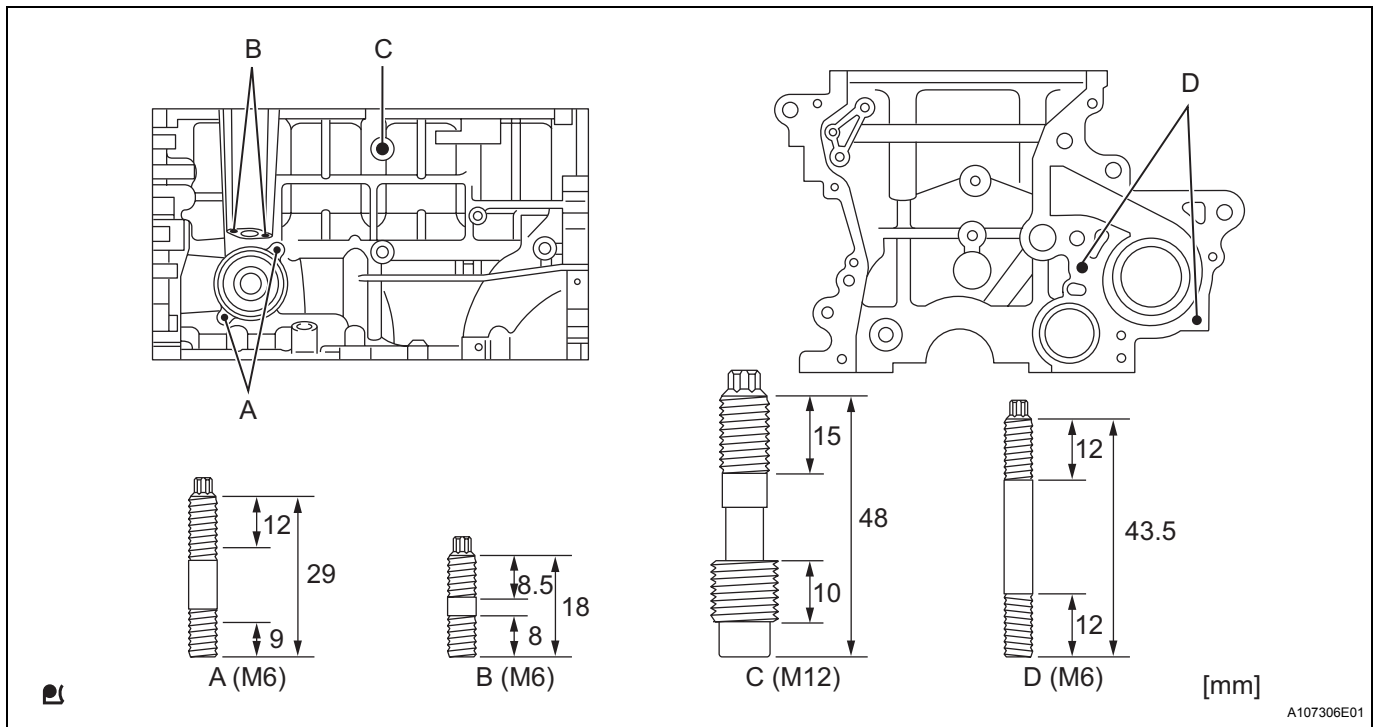

- (a) Using "Torx" socket wrench E5, install the 7 stud bolts.

Torque: 5.0 N*m (51 kgf*cm, 44 in.*lbf) (for Stud bolt A, B and D)

11 N*m (112 kgf*cm, 8.1 ft.*lbf) (for Stud bolt C)

NOTICE:

The lower threads of the bolt are installed into the cylinder block.

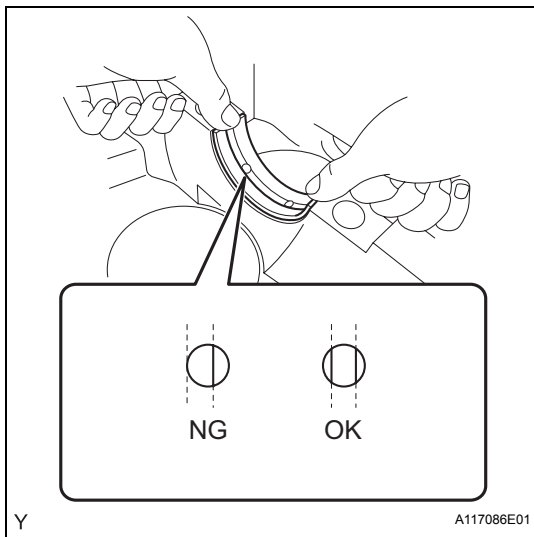

5. INSTALL CRANKSHAFT BEARING

- (a) Align the crankshaft bearing (upper) with the oil hole of the cylinder block and install the bearing.

NOTICE:

Do not apply engine oil to the bearing or its contact surface.

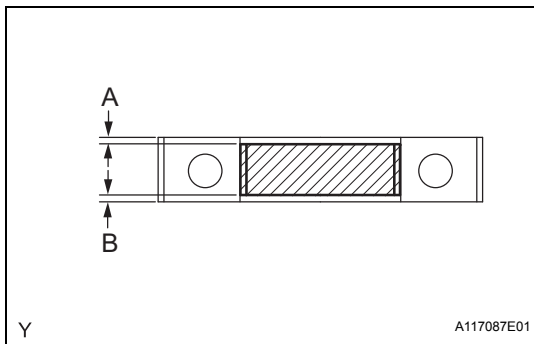

- (b) Align the crankshaft bearing (lower) with the bearing cap and install the crankshaft bearing cap.

NOTICE:

- Install the bearing cap so that the gap between A and B is less than 0.7 mm (0.028 in.).
- Do not apply engine oil to the bearing or its contact surface.

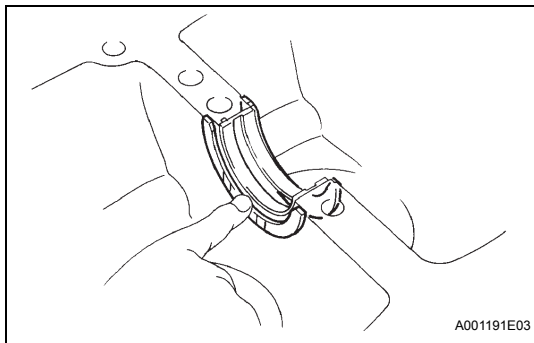

6. INSTALL CRANKSHAFT THRUST WASHER UPPER

- (a) Install the 2 thrust washers onto the No. 3 journal position of the cylinder block with the oil grooves facing outward.
- (b) Apply engine oil to the upper bearing and install the crankshaft onto the cylinder block.

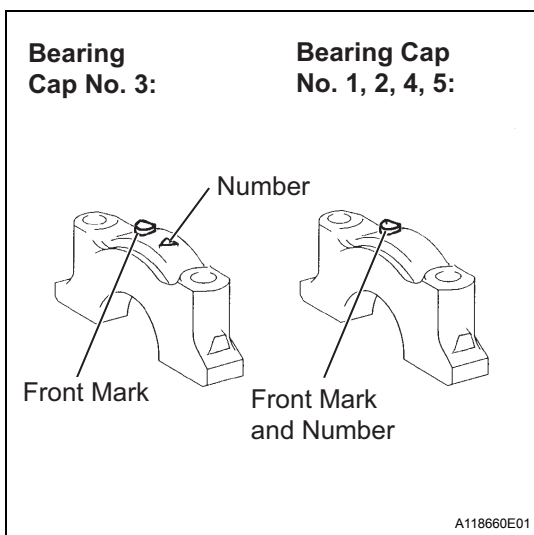

7. INSTALL CRANKSHAFT

- (a) Examine the front marks and numbers and install the bearing caps onto the cylinder block.
- (b) Apply a light coat of engine oil to the threads of the bearing cap bolts.

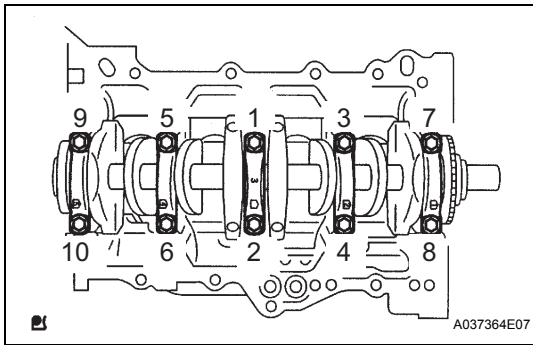

- (c) Using SST, tighten the bolts in several steps to the specified torque in the sequence shown in the illustration (*1).

SST 09011-38121

Torque: 22 N*m (224 kgf*cm, 16 ft.*lbf)

NOTICE:

Check that the crankshaft turns smoothly.

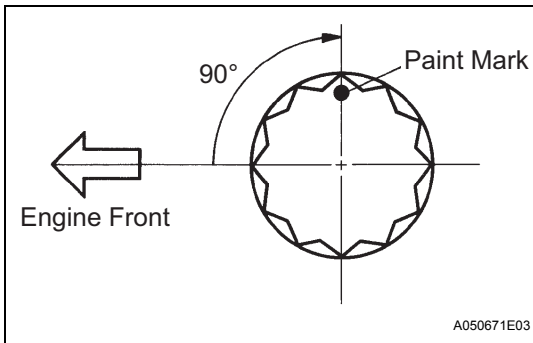

- (d) Mark the front of the bearing cap bolts with paint.
 (e) Retighten the bearing cap bolts by 90° in the same sequence as step (*1).
 (f) Check that the painted mark is now at a 90° angle from the front.

8. INSPECT CRANKSHAFT THRUST CLEARANCE (See page [EM-174](#))

9. INSPECT CRANKSHAFT OIL CLEARANCE (See page [EM-179](#))

10. INSTALL WITH PIN PISTON SUB-ASSEMBLY

- (a) Coat the piston pin and pin holes in the piston with engine oil.
 (b) Align the cavity of the piston with the protruding portion on the connecting rod.

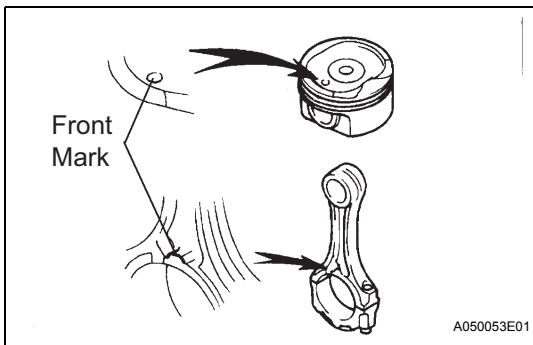

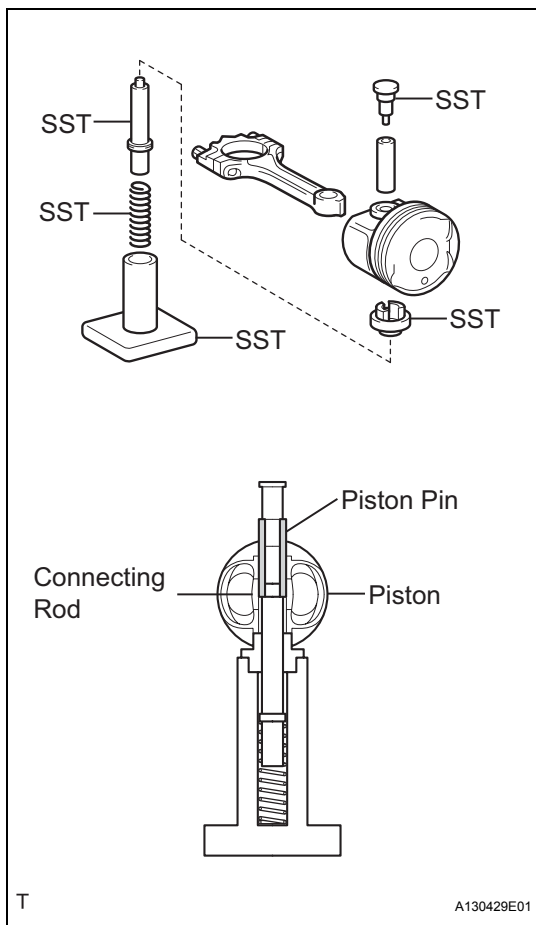

- (c) Using SST, press in the piston pin.
SST 09221-25026 (09221-00021, 09221-00030, 09221-00090, 09221-00150, 09221-00100)

NOTICE:

Keep the pistons, pins, rings, connecting rods and bearings in the correct order so that they can be returned to the original locations when reassembled.

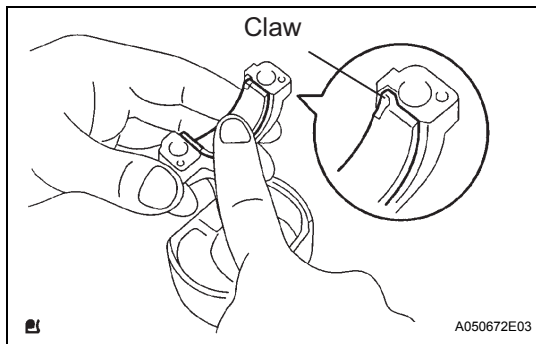
EM**11. INSTALL CONNECTING ROD BEARING**

- (a) Align the bearing claw with the groove of the connecting rod or connecting cap.

NOTICE:

Clean the back side of the bearing and the bearing surface of the connecting rod and keep them free of oil.

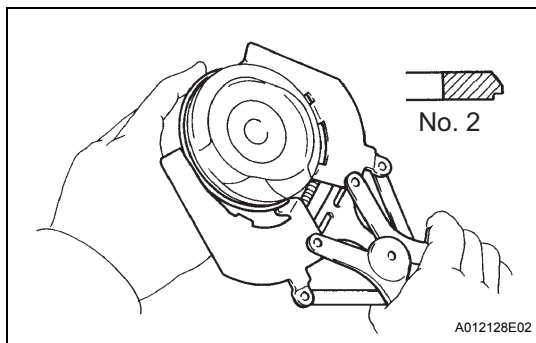
**12. INSTALL PISTON RING SET****HINT:**

When reusing the piston rings, install them onto the matched pistons with the surfaces facing correctly.

- (a) Install the oil ring expander and 2 side rails by hand.
 (b) Using a piston ring expander, install the 2 compression rings.

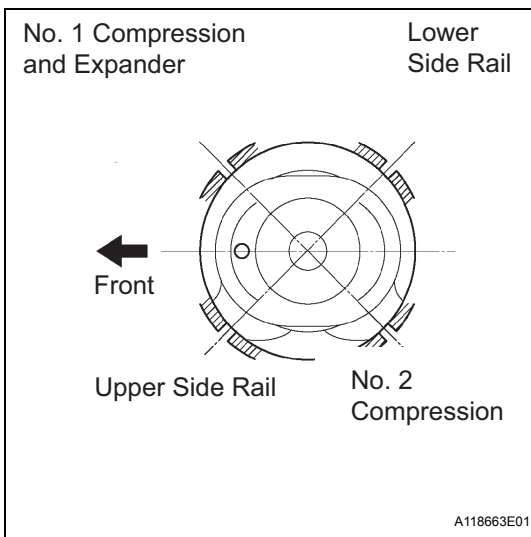

- (c) Position the piston rings so that the ring ends are as shown.

13. INSTALL PISTON SUB-ASSEMBLY WITH CONNECTING ROD

- (a) Apply engine oil to the cylinder walls, the pistons, and the surfaces of the connecting rod bearings.
- (b) Check the position of the piston ring ends.

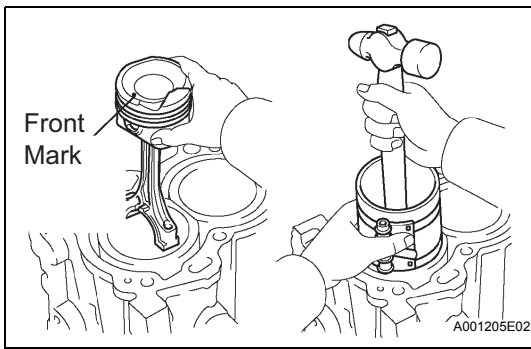

- (c) Using a piston ring compressor, push the correctly numbered piston and connecting rod assemblies into each cylinder with the front mark on the piston facing forward.

NOTICE:

- Clean the back side of the bearing and the bearing surface of the connecting rod cap and keep them free of oil.
- Match the numbered connecting rod cap with the connecting rod.

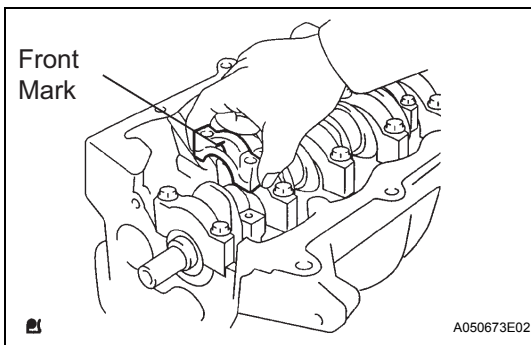

- (d) Make sure that the connecting rod and its cap are in the correct combination and that the front mark of the cap is facing in the correct mounting orientation, then install the cap onto the connecting rod.
- (e) Apply a light coat of engine oil to the threads of the connecting rod cap bolts.

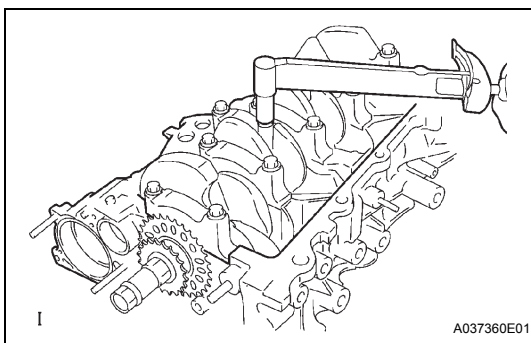

- (f) Using SST, tighten the bolts in several steps to the specified torque.

SST 09205-16010

Torque: 15 N*m (153 kgf*cm, 11 ft.*lbf)

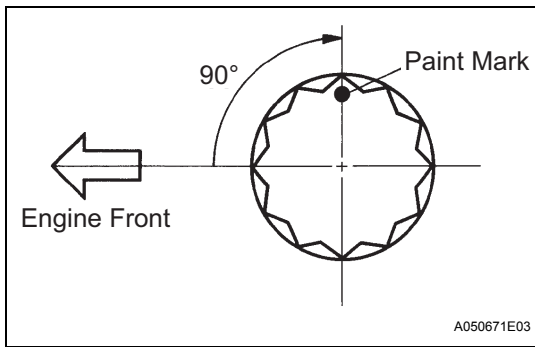

- (g) Mark the front of the connecting cap bolts with paint.
- (h) Retighten the cap bolts by 90° as shown.
- (i) Check that the crankshaft turns smoothly.

14. INSPECT CONNECTING ROD THRUST CLEARANCE (See page EM-173)

15. INSPECT CONNECTING ROD OIL CLEARANCE (See page EM-173)

16. INSTALL STUD BOLT

- (a) Using "Torx" socket wrench E5, install the 4 stud bolts.

Torque: 5.0 N*m (51 kgf*cm, 44 in.*lbf)

EM

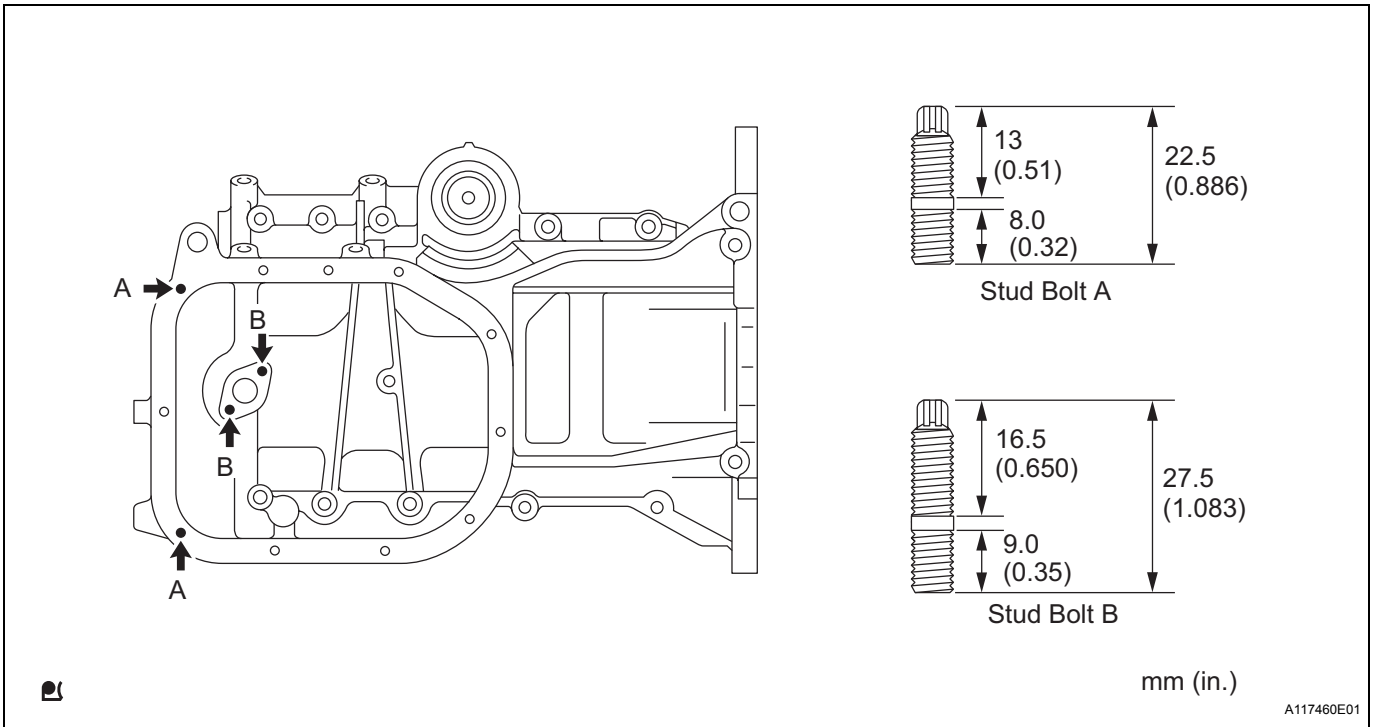

17. INSTALL OIL PAN SUB-ASSEMBLY

- (a) Remove any old packing material from the contact surface.
- (b) Apply a continuous bead of seal packing (Diameter 2.0 mm to 3.0 mm (0.079 to 0.118 in.)) to the oil pan mating surface as shown in the illustration.

Seal packing:

Toyota Genuine Seal Packing Black, Three Bond 1207B or Equivalent

NOTICE:

- Remove any oil from the contact surface.
- Install the oil pan within 3 minutes of applying the seal packing.
- Do not expose the seal to engine oil for at least within 2 hours after the installation.

- (c) Install 2 new O-rings onto the cylinder block.

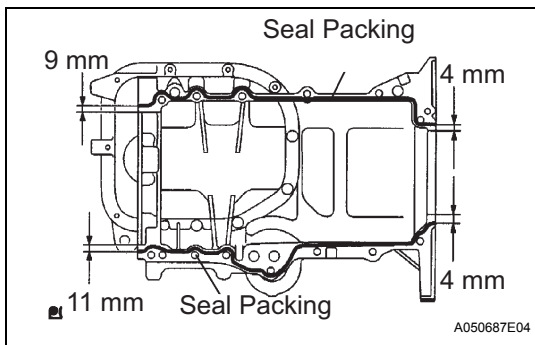

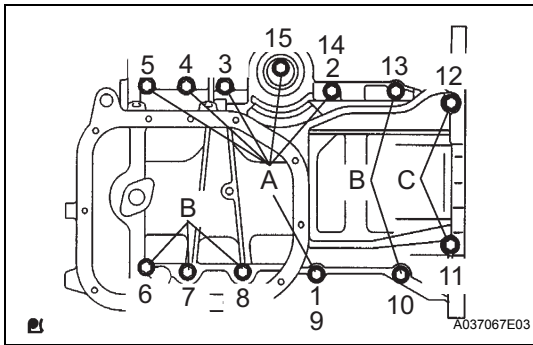

- (d) Using several steps, install and tighten the 13 bolts uniformly in the sequence shown in the illustration.

Torque: 24 N*m (245 kgf*cm, 18 ft.*lbf)

HINT:

Each bolt length is as follows:

Bolt A 49 mm (1.93 in.)

Bolt B 88 mm (3.47 in.)

Bolt C 144 mm (5.67 in.)

18. INSTALL OIL STRAINER SUB-ASSEMBLY

- (a) Install a new gasket and the oil strainer with the 2 nuts and the bolt.

Torque: 11 N*m (112 kgf*cm, 8.1 ft.*lbf)

19. INSTALL OIL PAN SUB-ASSEMBLY NO. 2

- (a) Remove any old packing material from the contact surface.

- (b) Apply a continuous bead of seal packing (Diameter 2.5 to 3.5 mm (0.0984 to 0.1378 in.)) to the oil pan mating surface as shown in the illustration.

Seal packing:

Toyota Genuine Seal Packing Black, Three Bond 1207B or Equivalent

NOTICE:

- Remove any oil from the contact surface.
- Install the oil pan within 3 minutes of applying the seal packing.
- Do not expose the seal to engine oil for at least 2 hours after the installation.
- Do not start the engine for at least 2 hours after the installation.

- (c) Install oil pan No. 2 with the 9 bolts and the 2 nuts.

Torque: 9.0 N*m (92 kgf*cm, 80 in.*lbf)

- (d) Install the drain plug with a new gasket.

Torque: 38 N*m (382 kgf*cm, 28 ft.*lbf)

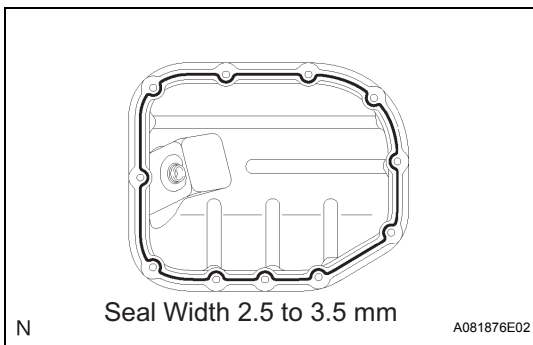

20. INSTALL OIL FILTER UNION

- (a) Using a 12 mm hexagon wrench, install the oil filter union.

Torque: 30 N*m (306 kgf*cm, 22 ft.*lbf)

21. INSTALL OIL FILTER SUB-ASSEMBLY

- (a) Check and clean the oil filter installation surface.

- (b) Apply clean engine oil to the gasket of a new oil filter.

- (c) Gently screw the oil filter into place, and tighten it until the gasket comes into contact with the seat.

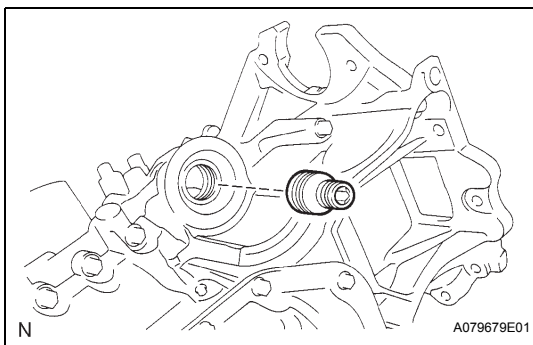

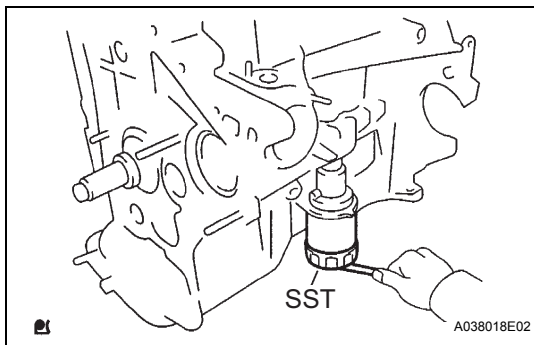

- (d) Using SST, tighten it an additional 3/4 turn.

SST 09228-06501

HINT:

When using a torque wrench, tighten it to the specified torque.

Torque: 13 N*m (133 kgf*cm, 9.5 ft.*lbf)

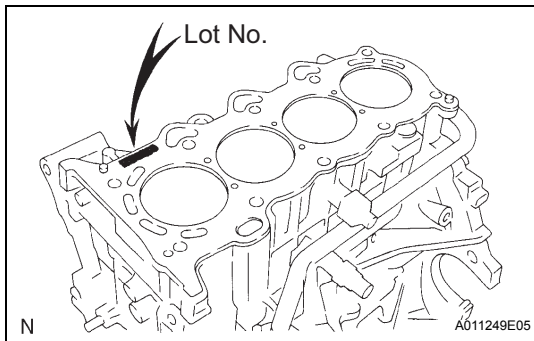

22. INSTALL CYLINDER HEAD GASKET

- (a) Place a new cylinder head gasket on the cylinder block with the Lot No. stamp facing upward.

NOTICE:

- Remove any oil from the contact surface.
- Pay attention to the mounting orientation of the cylinder head gasket.
- Place the cylinder head on the cylinder head gently in order not to damage the gasket.

23. INSTALL CYLINDER HEAD SUB-ASSEMBLY

HINT:

The cylinder head bolts are tightened in 2 successive steps.

- (a) Apply a light coat of engine oil to the threads of the cylinder head bolts.
- (b) Using several steps, install and tighten the 10 cylinder head bolts and plate washers uniformly with an 8 mm bi-hexagon wrench in the sequence shown in the illustration.

Torque: 29 N*m (300 kgf*cm, 22 ft.*lbf)

- (c) Mark the front of the cylinder head bolt with paint.

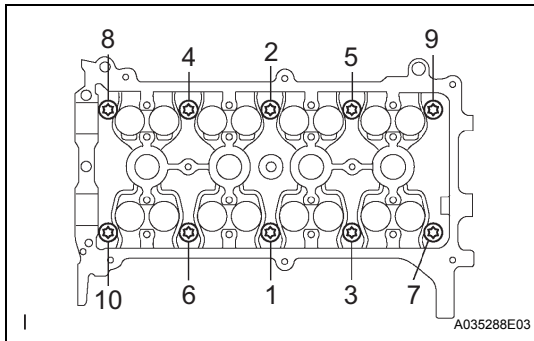

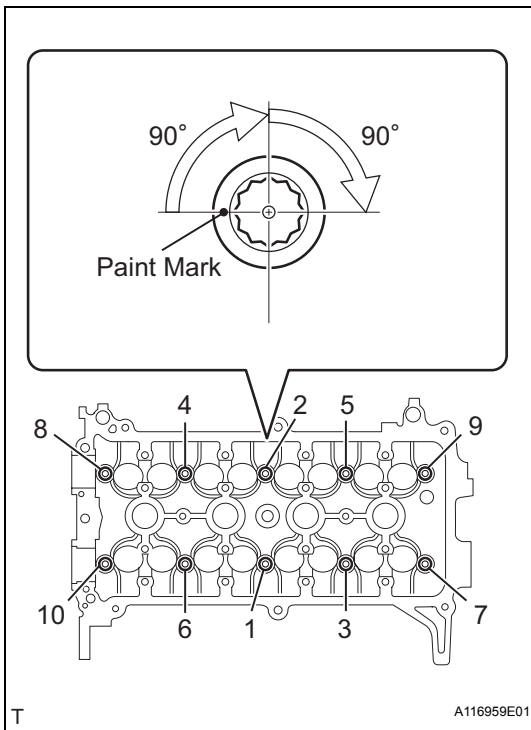

- (d) Retighten the cylinder head bolts by 90° and then an additional 90° as shown in the illustration.
- (e) Check that the paint mark is now at a 180° angle from the front.

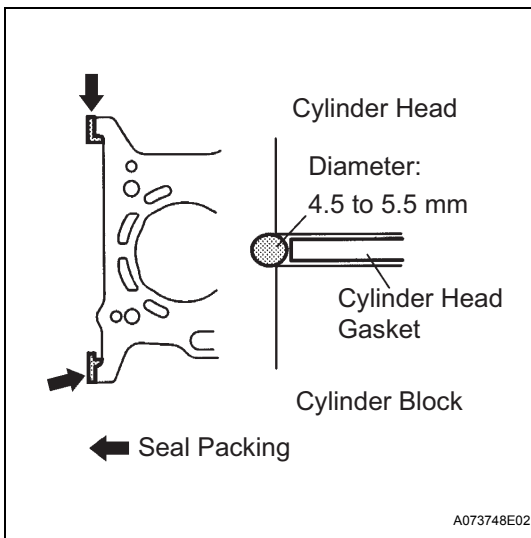

- (f) Apply a continuous bead of seal packing (Diameter 4.5 to 5.5 mm (0.177 to 0.217 in.)) as shown in the illustration.

Seal Packing:

Toyota Genuine Seal Packing Black, Three Bond 1207B or Equivalent

NOTICE:

- Remove any oil from the contact surface.
- Install the oil pump assembly within 3 minutes and tighten the bolts within 15 minutes of applying seal packing.

24. INSTALL ENGINE REAR OIL SEAL

- (a) Apply MP grease to a new oil seal lip.

NOTICE:

Keep the seal lip free of foreign matter.

- (b) Using SST and a hammer, tap in the oil seal until its surface is flush with the rear oil seal retainer edge.

SST 09223-56010

NOTICE:

- Do not tap the oil seal at an angle.
- Wipe any extra grease off the crankshaft.

25. INSTALL CAMSHAFT TIMING GEAR ASSEMBLY

NOTICE:

Install the camshaft timing gear assembly onto the camshaft with the lock pin of the camshaft timing gear assembly released.

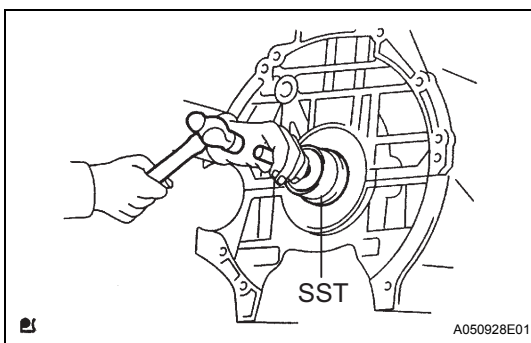

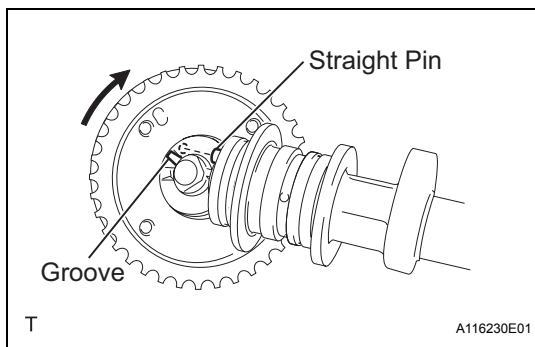

- (a) Put the camshaft timing gear assembly and camshaft together with the straight pin of the groove.
- (b) Turn the camshaft timing gear assembly clockwise while pushing it gently toward the camshaft. When the pin fits into the groove, push to ensure a good fit.

NOTICE:

Do not turn the camshaft timing gear in the retard direction (clockwise).

- (c) Check that there is no clearance between the gear fringe and the camshaft.
- (d) Tighten the flange bolt with the camshaft timing gear fixed.

Torque: 64 N*m (653 kgf*cm, 47 ft.*lbf)

NOTICE:

- Do not lock the camshaft timing gear assembly when tightening the bolt.
 - Release the lock pin of the camshaft timing gear assembly first, and tighten the bolt when the lock pin is locked in the most retarded position.
 - Tightening the bolts with the lock pin locked could cause breakage of the lock pin.
- (e) Check that the camshaft timing gear assembly moves smoothly in the retard direction (clockwise) and is locked in the most retarded position.

26. INSTALL CAMSHAFT

- (a) Apply a light coat of engine oil to the camshaft journals.
- (b) Place the camshaft on the cylinder head with the timing mark on the camshaft timing gear facing upward.
- (c) Examine the front marks and numbers and tighten the bolts in the sequence shown in the illustration.

Torque: 13 N*m (129 kgf*cm, 9.4 ft.*lbf)

NOTICE:

Tighten each bolt uniformly while keeping the camshaft level.

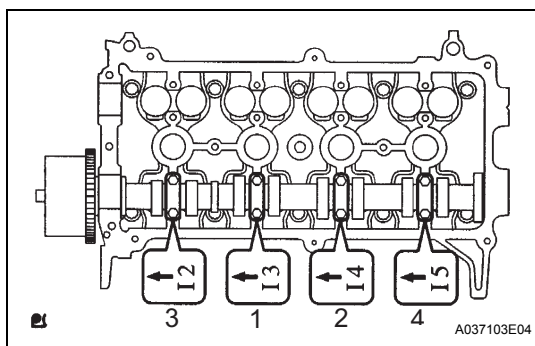

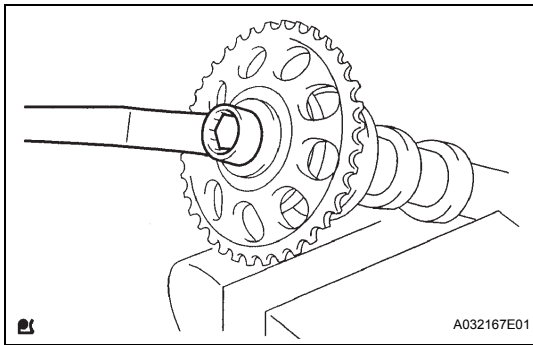
**27. INSTALL CAMSHAFT TIMING SPROCKET**

- (a) Clamp the camshaft in a vice.
- (b) Align the knock pin hole in the camshaft timing sprocket with the knock pin of the camshaft, and install the camshaft timing sprocket.

Torque: 64 N*m (653 kgf*cm, 47 ft.*lbf)

NOTICE:

Do not damage the camshaft.

28. INSTALL NO. 2 CAMSHAFT

- (a) Apply a light coat of engine oil to the camshaft journals.
- (b) Place the camshaft on the cylinder head with the timing mark on the camshaft timing gear facing upward.
- (c) Examine the front marks and numbers on camshaft bearing caps No. 1 and No. 2 and check that the sequence is as shown in the illustration. Then uniformly tighten the bolts, in several steps, in the sequence shown in the illustration.

Torque: 13 N*m (129 kgf*cm, 9.4 ft.*lbf) for bearing cap No. 2
23 N*m (235 kgf*cm, 17 ft.*lbf) for bearing cap No. 1

NOTICE:

Tighten each bolt uniformly while keeping the camshaft level.

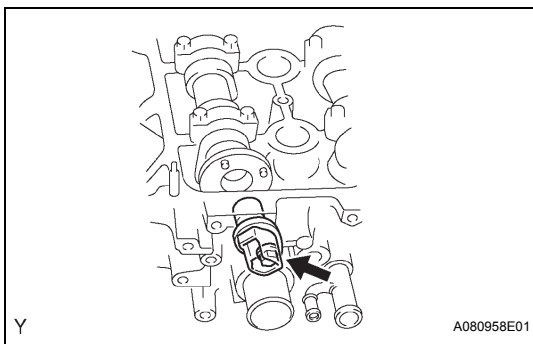
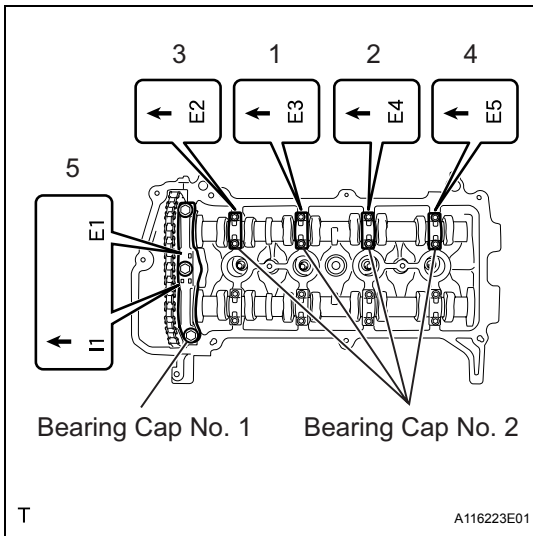
**29. INSTALL CAMSHAFT POSITION SENSOR**

- (a) Apply engine oil to the O-ring.

NOTICE:

If the O-ring is damaged, replace the camshaft position sensor.

- (b) Install the camshaft position sensor with the bolt.

Torque: 8.0 N*m (82 kgf*cm, 71 in.*lbf)

TDC:

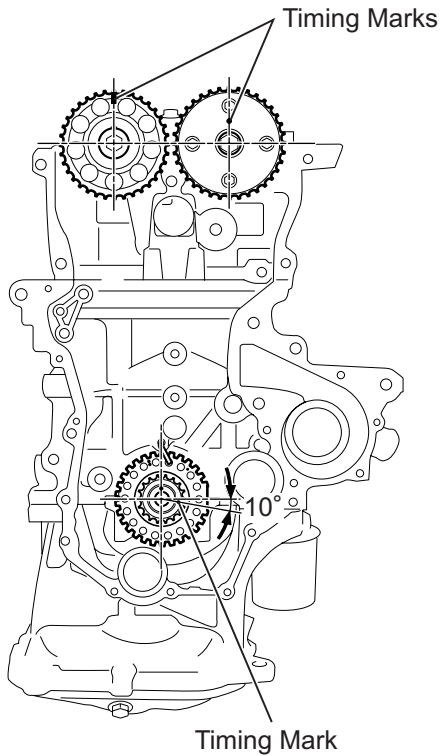

T

A116571E01

30. INSTALL CHAIN SUB-ASSEMBLY

- (a) Make sure that all the timing marks are in the positions (TDC) shown in the illustration.

HINT:

The positions of the timing marks may differ from the predetermined positions due to the force of the valve spring.

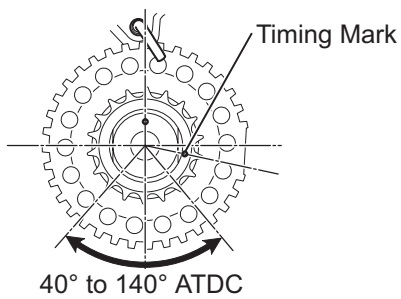

T

A116573E01

- (b) Set the timing mark of the crankshaft in a position between 40 and 140°ATDC, as illustrated.

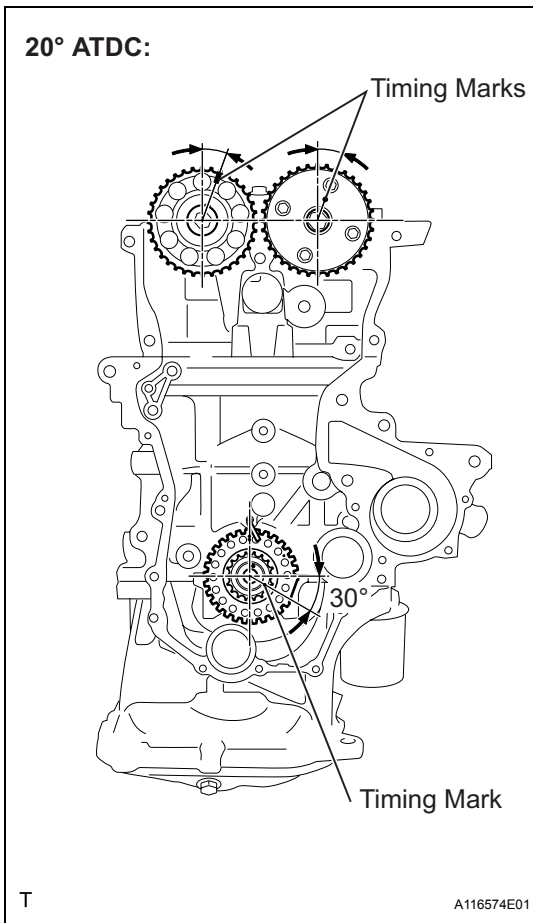

- (c) Set the camshaft timing gear and the camshaft timing sprocket in the positions (20°ATDC) shown in the illustration.
- (d) Set the crankshaft in the position (20°ATDC) shown in the illustration.

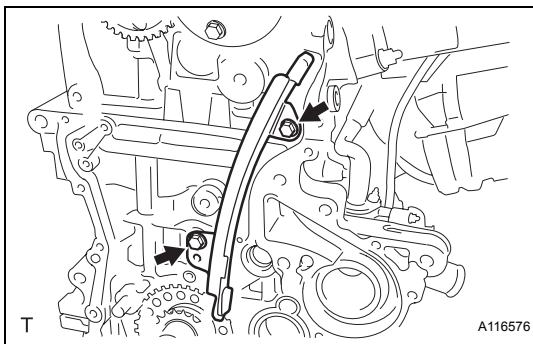

- (e) Install chain vibration damper No. 1 with the 2 bolts.
Torque: 9.0 N*m (92 kgf*cm, 80 in.*lbf)

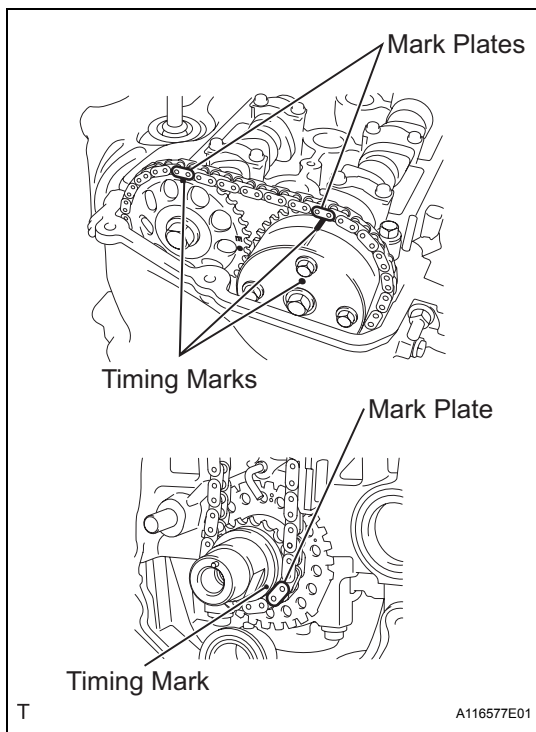

- (f) Align the timing marks of the camshaft with the mark plates of the timing chain and install the timing chain.

HINT:

Align the timing marks with the mark plates while turning the hexagonal service portion of the camshaft using a wrench.

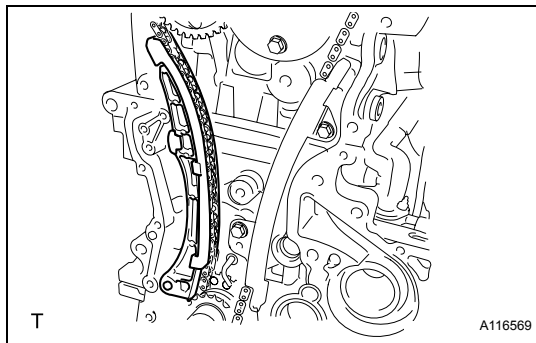

31. INSTALL CHAIN TENSIONER SLIPPER

- (a) Install the chain tensioner slipper.

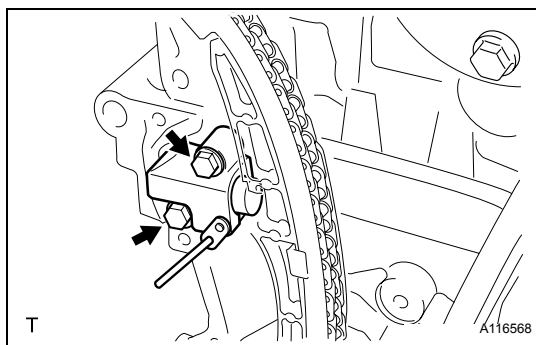

32. INSTALL CHAIN TENSIONER ASSEMBLY NO. 1

- (a) Install chain tensioner assembly No. 1 with the 2 bolts.

Torque: 9.0 N*m (92 kgf*cm, 80 in.*lbf)

- (b) Remove the bar from chain tensioner assembly No. 1.

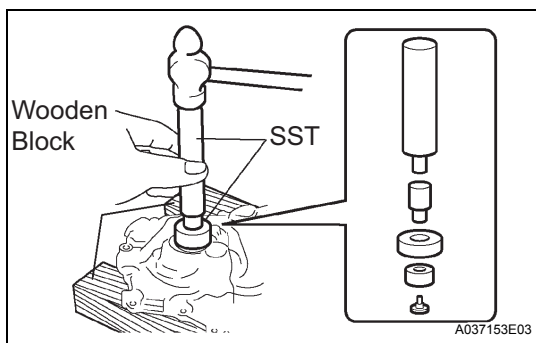

33. INSTALL OIL PUMP SEAL

- (a) Using SST and a hammer, tap in a new oil seal until its surface is flush with the timing chain cover edge.

SST 09950-60010 (09951-00250, 09951-00380, 09952-06010), 09950-70010 (09951-07100)

NOTICE:

- Do not tap the oil seal at an angle.
- Keep the seal lip free of foreign matter.

- (b) Apply MP grease to the oil seal lip.

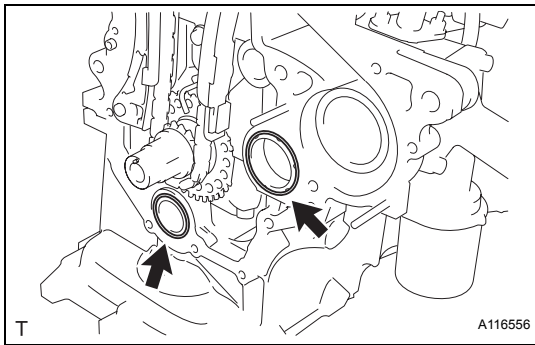
**34. INSTALL OIL PUMP ASSEMBLY**

- (a) Install 2 new O-rings in the 2 locations shown in the illustration.

(b) Apply seal packing to the oil pump assembly, cylinder head and cylinder block as shown in the illustration.

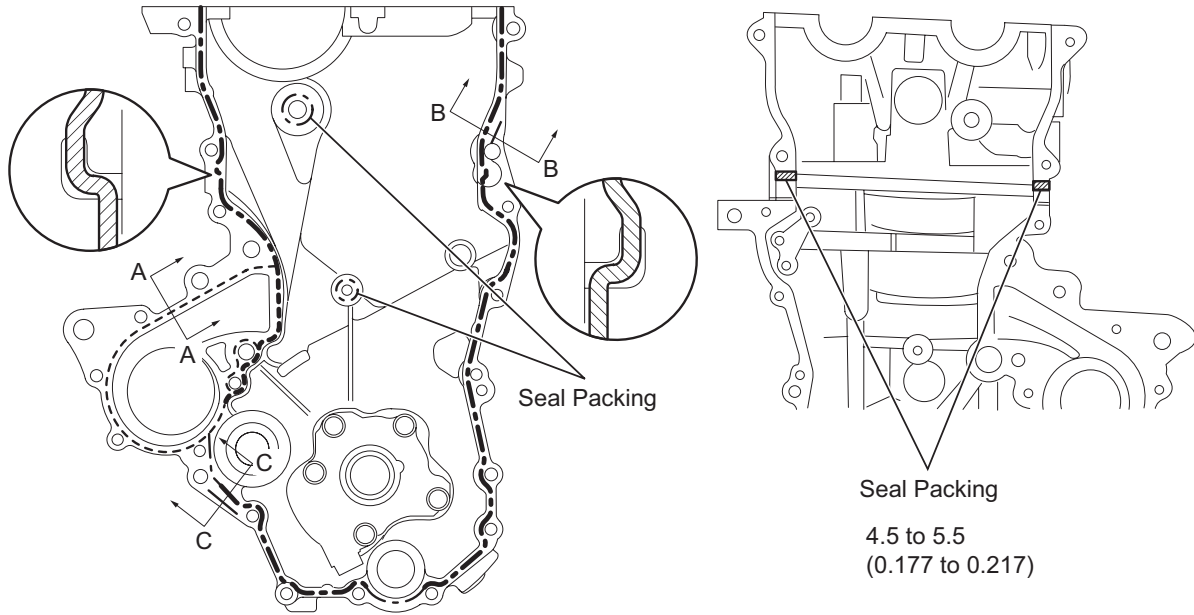

A-A
1.5 to 2.0
(0.059 to 0.079)

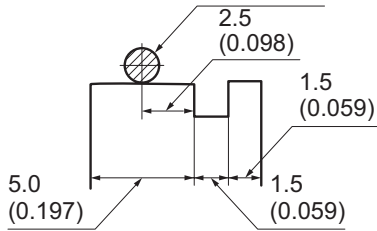

B-B, C-C

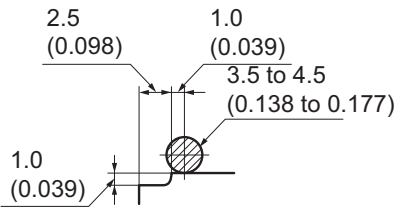
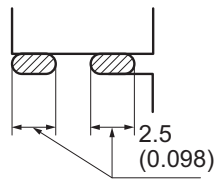

Seal Width (Other Part)

----- 3.5 to 4.5
(0.138 to 0.177)

----- 1.5 to 2.0
(0.059 to 0.079)

Seal Width (Water Pump Part)

----- 3.5 to 4.5
(0.138 to 0.177)

----- 1.5 to 2.0
(0.059 to 0.079)

mm (in.)

Seal packing:

Water pump part Toyota Genuine Seal Packing 1282B, Three Bond 1282B or Equivalent
Other part Toyota Genuine Seal Packing Black, Three Bond 1207B or Equivalent

NOTICE:

- Remove any oil from the contact surface.
- Install the oil pump assembly within 3 minutes and tighten the bolts and nut within 15 minutes of applying the the seal packing.
- Do not expose the seal to engine oil for at least 2 hours after the installation.

- (c) Align the keyway of the oil pump rotor with the rectangular portion of the crankshaft, and slide the oil pump into place.

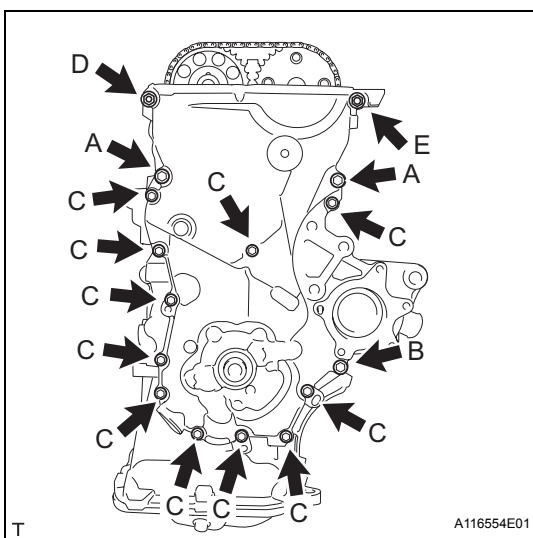
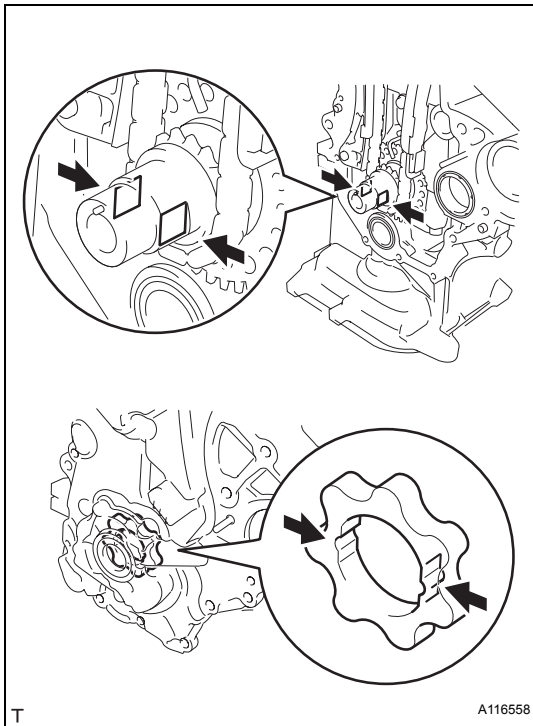

- (d) Install the oil pump assembly with the 15 bolts and nut. Tighten the bolts and nut uniformly in several steps.

Torque: 32 N*m (326 kgf*cm, 24 ft.*lbf) for bolt A
11 N*m (112 kgf*cm, 8.1 ft.*lbf) for bolt B
11 N*m (112 kgf*cm, 8.1 ft.*lbf) for bolt C
24 N*m (245 kgf*cm, 18 ft.*lbf) for nut D
24 N*m (245 kgf*cm, 18 ft.*lbf) for bolt E

NOTICE:

Install the mounting bracket and water pump within 15 minutes of installing the oil pump assembly.

HINT:

Each bolt length is as follows.

A: 30 mm (1.181 in.)

B: 35 mm (1.378 in.)

C: 20 mm (0.787 in.)

E: 20 to 14 mm (0.787 to 0.551 in.) Double ended bolt

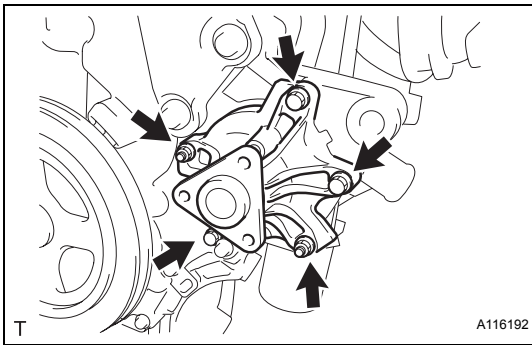
**35. INSTALL WATER PUMP ASSEMBLY**

- (a) Install the water pump and a new gasket with the 3 bolts and 2 nuts.

Torque: 11 N*m (112 kgf*cm, 8.1 ft.*lbf)

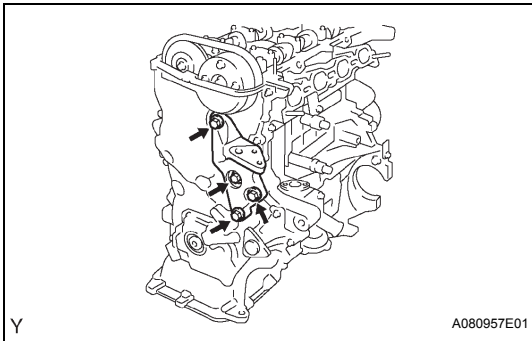
**36. INSTALL TRANSVERSE ENGINE ENGINE MOUNTING BRACKET**

- (a) Install the transverse engine mounting bracket with the 4 bolts.

Torque: 55 N*m (561 kgf*cm, 41 ft.*lbf)

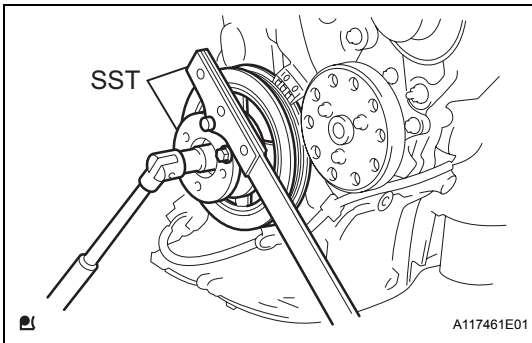
**37. INSTALL CRANKSHAFT DAMPER SUB-ASSEMBLY**

- (a) Align the pin hole in the crankshaft damper with the pin position and install the crankshaft damper sub-assembly.

- (b) Provisionally install the bolt.

- (c) Using 2 SSTs, tighten the bolt while holding the crankshaft damper sub-assembly.

SST 09213-14010 (91651-60865), 09330-00021

Torque: 128 N*m (1305 kgf*cm, 95 ft.*lbf)

NOTICE:

Check the SST installation positions when installing them, to avoid the SST fixing bolts from coming into contact with the oil pump assembly.

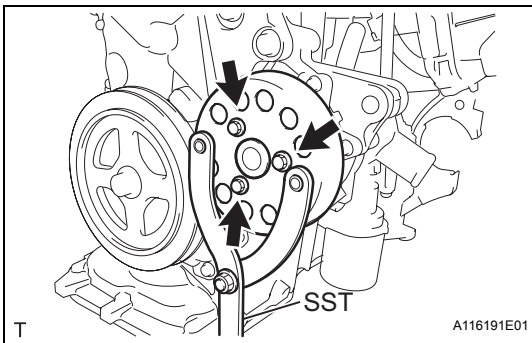
**38. INSTALL WATER PUMP PULLEY**

- (a) Using SST, install the pump pulley with the 3 bolts.

SST 09960-10010 (09962-01000, 09963-00700)

Torque: 15 N*m (153 kgf*cm, 11 ft.*lbf)

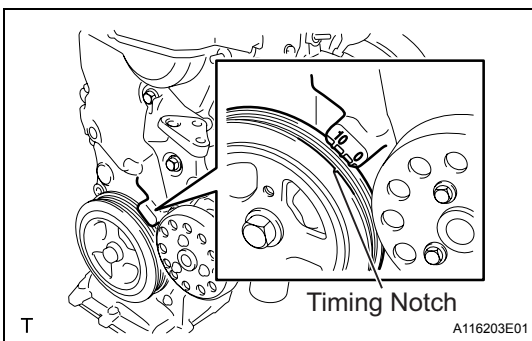
**39. INSPECT VALVE CLEARANCE**

- (a) Set the No. 1 cylinder to TDC/compression.

- (1) Turn the crankshaft damper, and align its timing notch with the timing mark "0" of the oil pump.

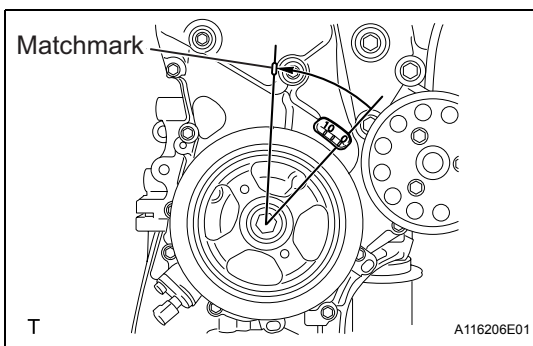
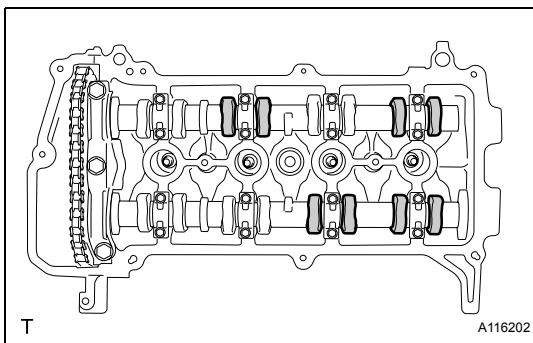
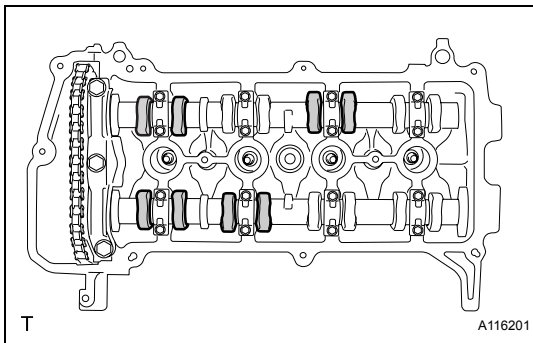
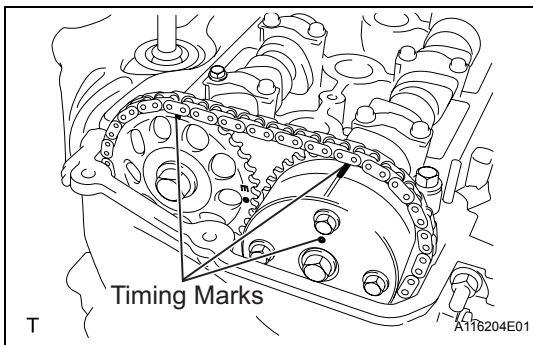

- (2) Check that the timing marks on the camshaft timing sprocket and camshaft timing gear are all facing upward, as shown in the illustration.
HINT:
If not, turn the crankshaft 1 complete revolution (360°) and align the marks as above.

- (b) Check the valves indicated in the illustration.
- (1) Using a feeler gauge, measure the clearance between the valve lifter and camshaft.
Valve clearance (cold):
for intake:
0.15 to 0.25 mm (0.006 to 0.010 in.)
for exhaust:
0.25 to 0.35 mm (0.010 to 0.014 in.)
- (2) Record any out-of-specification valve clearance measurements. They will be used later to determine the required replacement adjusting shim.
- (c) Turn the crankshaft 1 complete revolution (360°) and align its timing notch with timing mark "0" of the oil pump.
- (d) Check the valves indicated in the illustration.
- (1) Using a feeler gauge, measure the clearance between the valve lifter and camshaft.
Valve clearance (cold):
for Intake:
0.15 to 0.25 mm (0.006 to 0.010 in.)
for Exhaust:
0.25 to 0.35 mm (0.010 to 0.014 in.)
- (2) Record any out-of-specification valve clearance measurements. They will be used later to determine the required replacement adjusting shim.

40. ADJUST VALVE CLEARANCE

NOTICE:

When rotating the camshaft with the timing chain removed, rotate the crankshaft damper counterclockwise 40° from the TDC and align its timing notch with the matchmark of the timing chain cover to prevent the pistons from coming into contact with the valves.

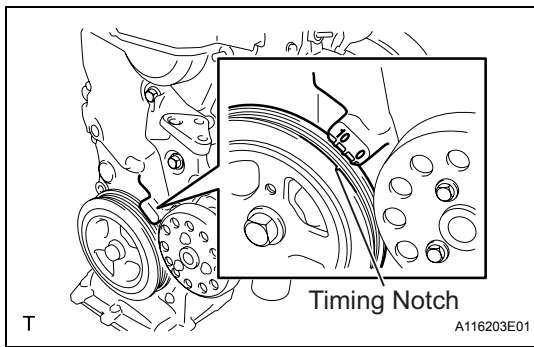

- (a) Set the No. 1 cylinder to TDC/compression.
 (1) Turn the crankshaft damper, and align its timing notch with timing mark "0" of the oil pump.

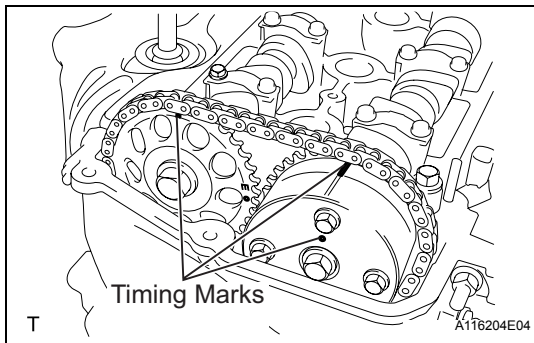

- (2) Check that the timing marks on the camshaft timing sprocket and camshaft timing gear are all facing upward as shown in the illustration.
 HINT:
 If not, turn the crankshaft 1 complete revolution (360°) and align the marks as above.

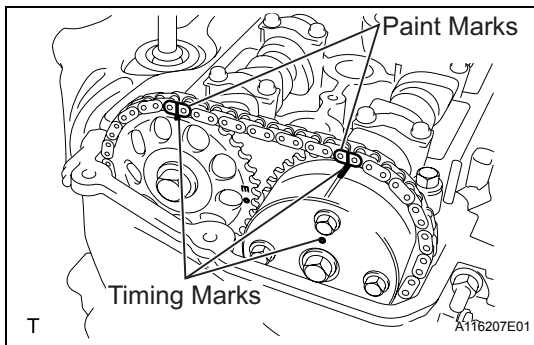

- (b) Put paint marks on the chain in the places where the timing marks of the camshaft timing sprocket and the camshaft timing gear are located.

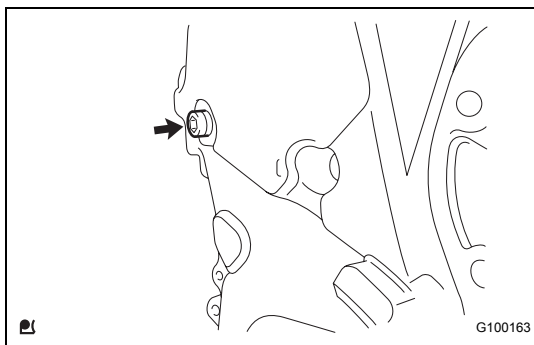

- (c) Using an 8 mm hexagon wrench, remove the screw plug.

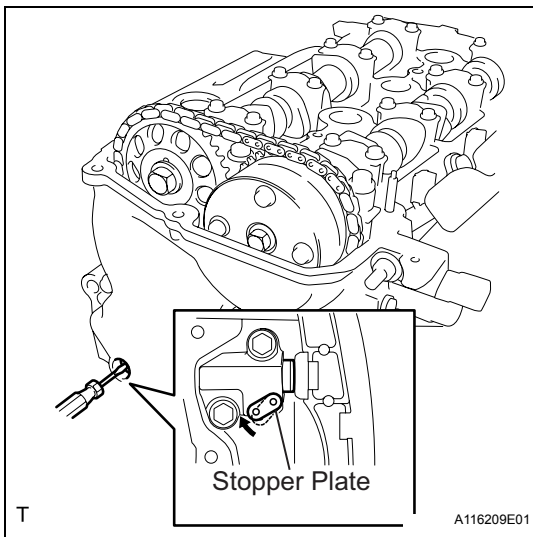

- (d) Insert a screwdriver into the service hole in the chain tensioner to pull the stopper plate of the chain tensioner upward.

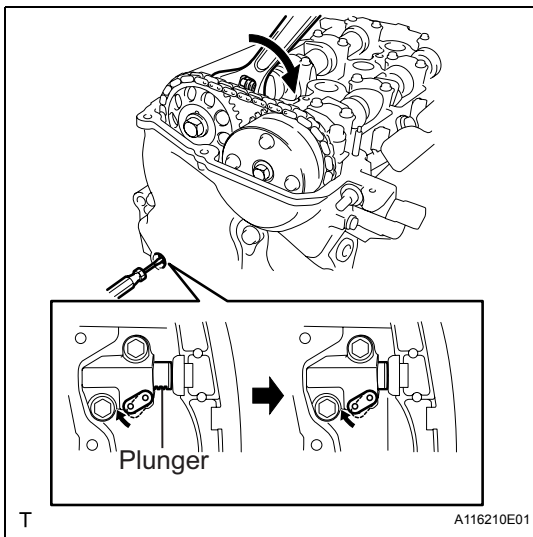

- (e) Using a wrench, rotate the No. 2 camshaft clockwise to push in the plunger of the chain tensioner.

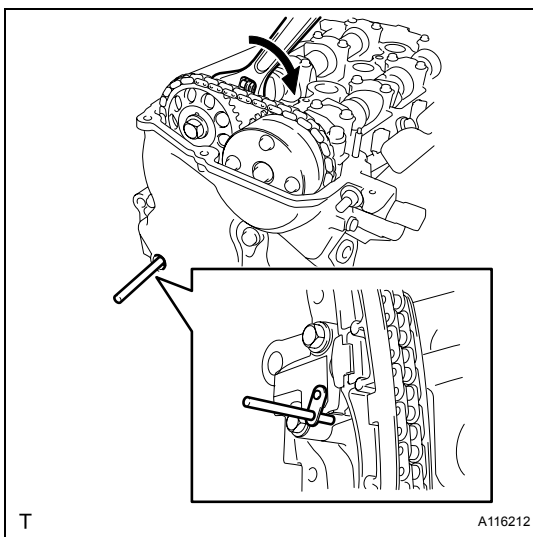

- (f) Remove the screwdriver from the service hole, then align the hole in the stopper plate with the service hole and insert a 3 mm (0.12 in.) diameter bar into the holes to hold the stopper plate.

HINT:

- Fix the stopper plate using the bar while rotating the camshaft right and left slightly.
- Hold the bar with tape so that it does not come out.

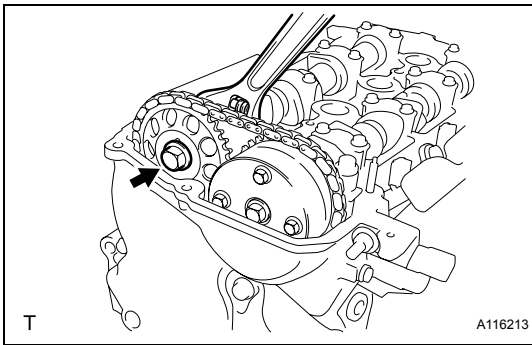

- (g) Using a wrench, hold the hexagonal lobe of No. 2 camshaft and remove the flange bolt.

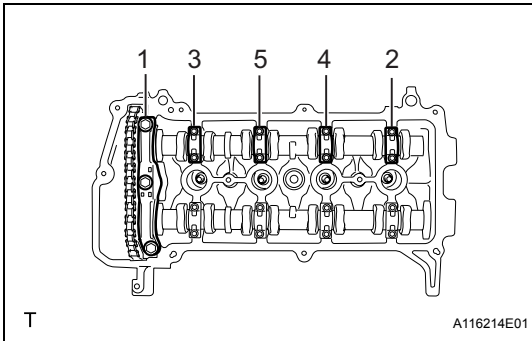

- (h) Using several steps, loosen and remove the 11 bearing cap bolts uniformly in the sequence shown in the illustration, then remove camshaft bearing cap No. 1 and camshaft bearing cap No. 2.

NOTICE:

Loosen each bolt uniformly while keeping the camshaft level.

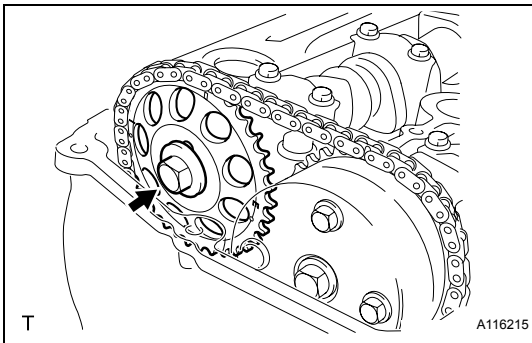

- (i) Remove the flange bolt and remove the camshaft timing sprocket.

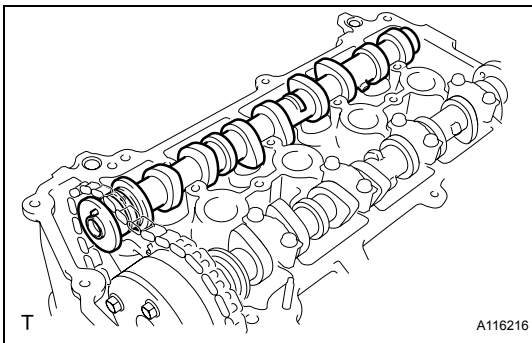

- (j) Remove the No. 2 camshaft.

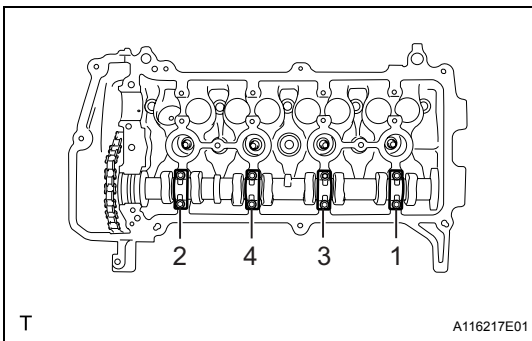

- (k) Using several steps, loosen and remove the 8 bearing cap bolts uniformly in the sequence shown in the illustration, then remove camshaft bearing cap No. 2.

NOTICE:

Loosen the bolts uniformly while keeping the camshaft level.

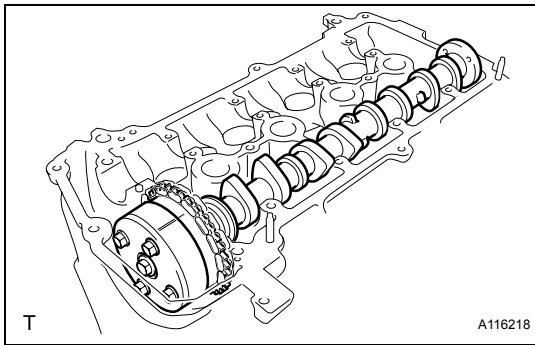

- (l) Hold the chain by hand, and remove the camshaft and the camshaft timing gear assembly.

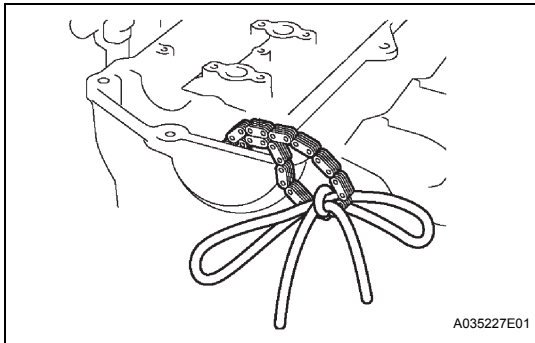

- (m) Tie the chain with a piece of string as shown in the illustration.

- (n) Remove the valve lifters.

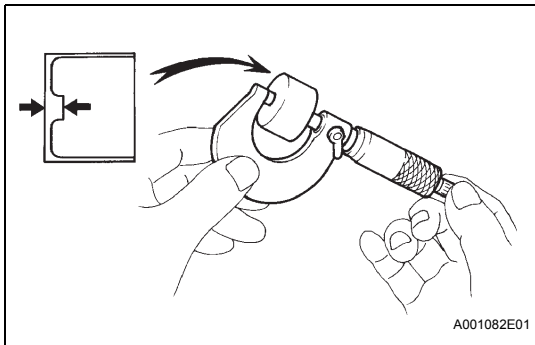

- (o) Using a micrometer, measure the thickness of the removed lifter.
- (p) Calculate the thickness of the new lifter so that the valve clearance comes to within the specified values.

A	Thickness of new lifter
B	Thickness of used lifter
C	Measured valve clearance

Valve clearance:

Intake $A = B + (C - 0.20 \text{ mm (0.008 in.)})$

Exhaust $A = B + (C - 0.30 \text{ mm (0.012 in.)})$

- (q) Select a new lifter with a thickness as close to the calculated values as possible.

HINT:

Lifters are available in 35 sizes in increments of 0.020 mm (0.0008 in.), from 5.060 mm (0.1992 in.) to 5.740 mm (0.2260 in.).

Measured clearance mm(in.)	Installed lifter thickness mm(in.)	0.000 - 0.030 (0.0000 - 0.0012)	0.031 - 0.050 (0.0012 - 0.0020)	0.051 - 0.070 (0.0020 - 0.0028)	0.071 - 0.090 (0.0028 - 0.0035)	0.091 - 0.110 (0.0036 - 0.0043)	0.111 - 0.130 (0.0044 - 0.0051)	0.131 - 0.149 (0.0052 - 0.0059)	0.150 - 0.250 (0.0059 - 0.0098)	0.251 - 0.270 (0.0099 - 0.0106)	0.271 - 0.290 (0.0107 - 0.0114)	0.291 - 0.310 (0.0115 - 0.0122)	0.311 - 0.330 (0.0122 - 0.0130)	0.331 - 0.350 (0.0130 - 0.0138)	0.351 - 0.370 (0.0138 - 0.0146)	0.371 - 0.390 (0.0146 - 0.0154)	0.391 - 0.410 (0.0154 - 0.0161)	0.411 - 0.430 (0.0162 - 0.0169)	0.431 - 0.450 (0.0170 - 0.0177)	0.451 - 0.470 (0.0178 - 0.0185)	0.471 - 0.490 (0.0185 - 0.0193)	0.491 - 0.510 (0.0193 - 0.0201)	0.511 - 0.530 (0.0201 - 0.0209)	0.531 - 0.550 (0.0209 - 0.0217)	0.551 - 0.570 (0.0217 - 0.0224)	0.571 - 0.590 (0.0225 - 0.0232)	0.591 - 0.610 (0.0233 - 0.0240)	0.611 - 0.630 (0.0241 - 0.0248)	0.631 - 0.650 (0.0248 - 0.0256)	0.651 - 0.670 (0.0256 - 0.0264)	0.671 - 0.690 (0.0264 - 0.0272)	0.691 - 0.710 (0.0272 - 0.0280)	0.711 - 0.730 (0.0280 - 0.0287)	0.731 - 0.750 (0.0288 - 0.0295)	0.751 - 0.770 (0.0296 - 0.0303)	0.771 - 0.790 (0.0304 - 0.0311)	0.791 - 0.810 (0.0311 - 0.0319)	0.811 - 0.830 (0.0319 - 0.0327)	0.831 - 0.850 (0.0327 - 0.0335)	0.851 - 0.870 (0.0335 - 0.0343)	0.871 - 0.890 (0.0343 - 0.0350)	0.891 - 0.910 (0.0351 - 0.0358)	0.911 - 0.930 (0.0359 - 0.0366)	
5.060 (0.1992)										12	14	16	18	20	22	24	26	28	30	32	34	36	38	40	42	44	46	48	50	52	54	56	58	60	62	64	66	68	70	72	74	74	74	
5.080 (0.2000)							06			14	16	18	20	22	24	26	28	30	32	34	36	38	40	42	44	46	48	50	52	54	56	58	60	62	64	66	68	70	72	74	74	74		
5.100 (0.2008)						06	06			16	18	20	22	24	26	28	30	32	34	36	38	40	42	44	46	48	50	52	54	56	58	60	62	64	66	68	70	72	74	74	74			
5.120 (0.2016)					06	06	06			18	20	22	24	26	28	30	32	34	36	38	40	42	44	46	48	50	52	54	56	58	60	62	64	66	68	70	72	74	74	74				
5.140 (0.2024)				06	06	06	06			20	22	24	26	28	30	32	34	36	38	40	42	44	46	48	50	52	54	56	58	60	62	64	66	68	70	72	74	74	74					
5.160 (0.2031)			06	06	06	06	08	10	12	22	24	26	28	30	32	34	36	38	40	42	44	46	48	50	52	54	56	58	60	62	64	66	68	70	72	74	74	74						
5.200 (0.2047)		06	06	08	10	12	14			26	28	30	32	34	36	38	40	42	44	46	48	50	52	54	56	58	60	62	64	66	68	70	72	74	74									
5.210 (0.2051)	06	06	08	10	12	14	16			28	30	32	34	36	38	40	42	44	46	48	50	52	54	56	58	60	62	64	66	68	70	72	74	74	74									
5.220 (0.2055)	06	06	08	10	12	14	16			28	30	32	34	36	38	40	42	44	46	48	50	52	54	56	58	60	62	64	66	68	70	72	74	74	74									
5.230 (0.2059)	06	08	10	12	14	16	18			30	32	34	36	38	40	42	44	46	48	50	52	54	56	58	60	62	64	66	68	70	72	74	74	74										
5.240 (0.2063)	06	08	10	12	14	16	18			30	32	34	36	38	40	42	44	46	48	50	52	54	56	58	60	62	64	66	68	70	72	74	74	74										
5.250 (0.2067)	06	10	12	14	16	18	20			32	34	36	38	40	42	44	46	48	50	52	54	56	58	60	62	64	66	68	70	72	74	74	74											
5.260 (0.2071)	08	10	12	14	16	18	20			32	34	36	38	40	42	44	46	48	50	52	54	56	58	60	62	64	66	68	70	72	74	74	74											
5.270 (0.2075)	10	12	14	16	18	20	22			34	36	38	40	42	44	46	48	50	52	54	56	58	60	62	64	66	68	70	72	74	74	74												
5.280 (0.2079)	10	12	14	16	18	20	22			34	36	38	40	42	44	46	48	50	52	54	56	58	60	62	64	66	68	70	72	74	74	74												
5.290 (0.2083)	12	14	16	18	20	22	24			36	38	40	42	44	46	48	50	52	54	56	58	60	62	64	66	68	70	72	74	74	74													
5.300 (0.2087)	12	14	16	18	20	22	24			36	38	40	42	44	46	48	50	52	54	56	58	60	62	64	66	68	70	72	74	74	74													
5.310 (0.2091)	14	16	18	20	22	24	26			38	40	42	44	46	48	50	52	54	56	58	60	62	64	66	68	70	72	74	74	74														
5.320 (0.2094)	14	16	18	20	22	24	26			38	40	42	44	46	48	50	52	54	56	58	60	62	64	66	68	70	72	74	74	74														
5.330 (0.2098)	16	18	20	22	24	26	28			40	42	44	46	48	50	52	54	56	58	60	62	64	66	68	70	72	74	74	74															
5.340 (0.2102)	16	18	20	22	24	26	28			40	42	44	46	48	50	52	54	56	58	60	62	64	66	68	70	72	74	74	74															
5.350 (0.2106)	18	20	22	24	26	28	30			42	44	46	48	50	52	54	56	58	60	62	64	66	68	70	72	74	74	74																
5.360 (0.2110)	18	20	22	24	26	28	30			42	44	46	48	50	52	54	56	58	60	62	64	66	68	70	72	74	74	74																
5.370 (0.2114)	20	22	24	26	28	30	32			44	46	48	50	52	54	56	58	60	62	64	66	68	70	72	74	74	74																	
5.380 (0.2118)	20	22	24	26	28	30	32			44	46	48	50	52	54	56	58	60	62	64	66	68	70	72	74	74	74																	
5.390 (0.2122)	22	24	26	28	30	32	34			46	48	50	52	54	56	58	60	62	64	66	68	70	72	74	74	74																		
5.400 (0.2126)	22	24	26	28	30	32	34			46	48	50	52	54	56	58	60	62	64	66	68	70	72	74	74	74																		
5.410 (0.2130)	24	26	28	30	32	34	36			48	50	52	54	56	58	60	62	64	66	68	70	72	74	74	74																			
5.420 (0.2134)	24	26	28	30	32	34	36			48	50	52	54	56	58	60	62	64	66	68	70	72	74	74	74																			
5.430 (0.2138)	26	28	30	32	34	36	38			50	52	54	56	58	60	62	64	66	68	70	72	74	74	74																				
5.440 (0.2142)	26	28	30	32	34	36	38			50	52	54	56	58	60	62	64	66	68	70	72	74	74	74																				
5.450 (0.2146)	28	30	32	34	36	38	40			52	54	56	58	60	62	64	66	68	70	72	74	74	74																					
5.460 (0.2150)	28	30	32	34	36	38	40			52	54	56	58	60	62	64	66	68	70	72	74	74	74																					
5.470 (0.2154)	30	32	34	36	38	40	42			54	56	58	60	62	64	66	68	70	72	74	74	74																						
5.480 (0.2157)	30	32	34	36	38	40	42			54	56	58	60	62	64	66	68	70	72	74	74	74																						
5.490 (0.2161)	32	34	36	38	40	42	44			56	58	60	62	64	66	68	70	72	74	74	74																							
5.500 (0.2165)	32	34	36	38	40	42	44			56	58	60	62	64	66	68	70	72	74	74	74																							
5.510 (0.2169)	34	36	38	40	42	44	46			58	60	62	64	66	68	70	72	74	74	74																								
5.520 (0.2173)	34	36	38	40	42	44	46			58	60	62	64	66	68	70	72	74	74	74																								
5.530 (0.2177)	36	38	40	42	44	46	48			60	62	64	66	68	70	72																												

Intake valve clearance (cold):
0.15 to 0.25 mm (0.006 to 0.010 in.)

EXAMPLE:

A 5.250 mm (0.2067 in.) lifter is installed, and the measured clearance is 0.400 mm (0.0158 in.). Replace the 5.250 mm (0.2067 in.) lifter with a new No. 46 lifter.

New Shim Thickness

Shim No.	Thickness	Shim No.	Thickness	Shim No.	Thickness
06	5.060 (0.1992)	30	5.300 (0.2087)	54	5.540 (0.2181)
08	5.080 (0.2000)	32	5.320 (0.2094)	56	5.560 (0.2189)
10	5.100 (0.2008)	34	5.340 (0.2102)	58	5.580 (0.2197)
12	5.120 (0.2016)	36	5.360 (0.2110)	60	5.600 (0.2205)
14	5.140 (0.2024)	38	5.380 (0.2118)	62	5.620 (0.2213)
16	5.160 (0.2031)	40	5.400 (0.2126)	64	5.640 (0.2220)
18	5.180 (0.2039)	42	5.420 (0.2134)	66	5.660 (0.2228)
20	5.200 (0.2047)	44	5.440 (0.2142)	68	5.680 (0.2236)
22	5.220 (0.2055)	46	5.460 (0.2150)	70	5.700 (0.2244)
24	5.240 (0.2063)	48	5.480 (0.2157)	72	5.720 (0.2252)
26	5.260 (0.2071)	50	5.500 (0.2165)	74	5.740 (0.2260)
28	5.280 (0.2079)	52	5.520 (0.2173)		

EM

Measured clearance mm(in.)	Installed lifter thickness mm(in.)	0.000 - 0.030 (0.0000 - 0.0012)	0.031 - 0.050 (0.0012 - 0.0020)	0.051 - 0.070 (0.0020 - 0.0028)	0.071 - 0.090 (0.0028 - 0.0035)	0.091 - 0.110 (0.0036 - 0.0043)	0.111 - 0.130 (0.0044 - 0.0051)	0.131 - 0.150 (0.0052 - 0.0059)	0.151 - 0.170 (0.0059 - 0.0067)	0.171 - 0.190 (0.0067 - 0.0075)	0.191 - 0.210 (0.0075 - 0.0083)	0.211 - 0.230 (0.0083 - 0.0091)	0.231 - 0.249 (0.0091 - 0.0098)	0.250 - 0.350 (0.0098 - 0.0138)	0.351 - 0.370 (0.0138 - 0.0146)	0.371 - 0.390 (0.0146 - 0.0154)	0.391 - 0.410 (0.0154 - 0.0161)	0.411 - 0.430 (0.0162 - 0.0169)	0.431 - 0.450 (0.0170 - 0.0177)	0.451 - 0.470 (0.0178 - 0.0185)	0.471 - 0.490 (0.0185 - 0.0193)	0.491 - 0.510 (0.0193 - 0.0201)	0.511 - 0.530 (0.0201 - 0.0209)	0.531 - 0.550 (0.0209 - 0.0217)	0.551 - 0.570 (0.0217 - 0.0224)	0.571 - 0.590 (0.0225 - 0.0232)	0.591 - 0.610 (0.0233 - 0.0240)	0.611 - 0.630 (0.0241 - 0.0248)	0.631 - 0.650 (0.0248 - 0.0256)	0.651 - 0.670 (0.0256 - 0.0264)	0.671 - 0.690 (0.0264 - 0.0272)	0.691 - 0.710 (0.0272 - 0.0280)	0.711 - 0.730 (0.0280 - 0.0287)	0.731 - 0.750 (0.0288 - 0.0295)	0.751 - 0.770 (0.0296 - 0.0303)	0.771 - 0.790 (0.0304 - 0.0311)	0.791 - 0.810 (0.0311 - 0.0319)	0.811 - 0.830 (0.0319 - 0.0327)	0.831 - 0.850 (0.0327 - 0.0335)	0.851 - 0.870 (0.0335 - 0.0343)	0.871 - 0.890 (0.0343 - 0.0350)	0.891 - 0.910 (0.0351 - 0.0358)	0.911 - 0.930 (0.0359 - 0.0366)	0.931 - 0.950 (0.0367 - 0.0374)	0.951 - 0.970 (0.0374 - 0.0382)	0.971 - 0.990 (0.0382 - 0.0390)	0.991 - 1.010 (0.0390 - 0.0398)	1.011 - 1.030 (0.0398 - 0.0406)
5.060 (0.1992)															12	14	16	18	20	22	24	26	28	30	32	34	36	38	40	42	44	46	48	50	52	54	56	58	60	62	64	66	68	70	72	74	74	74
5.080 (0.2000)												06			14	16	18	20	22	24	26	28	30	32	34	36	38	40	42	44	46	48	50	52	54	56	58	60	62	64	66	68	70	72	74	74	74	74
5.100 (0.2008)											06	06			16	18	20	22	24	26	28	30	32	34	36	38	40	42	44	46	48	50	52	54	56	58	60	62	64	66	68	70	72	74	74	74	74	74
5.120 (0.2016)											06	06	06		18	20	22	24	26	28	30	32	34	36	38	40	42	44	46	48	50	52	54	56	58	60	62	64	66	68	70	72	74	74	74	74	74	74
5.140 (0.2024)											06	06	06	08		20	22	24	26	28	30	32	34	36	38	40	42	44	46	48	50	52	54	56	58	60	62	64	66	68	70	72	74	74	74	74	74	74
5.160 (0.2031)											06	06	06	08	10		22	24	26	28	30	32	34	36	38	40	42	44	46	48	50	52	54	56	58	60	62	64	66	68	70	72	74	74	74	74	74	74
5.180 (0.2039)											06	06	06	08	10	12		24	26	28	30	32	34	36	38	40	42	44	46	48	50	52	54	56	58	60	62	64	66	68	70	72	74	74	74	74	74	74
5.200 (0.2047)											06	06	06	08	10	12	14		26	28	30	32	34	36	38	40	42	44	46	48	50	52	54	56	58	60	62	64	66	68	70	72	74	74	74	74	74	74
5.210 (0.2051)											06	06	06	08	10	12	14	16		28	30	32	34	36	38	40	42	44	46	48	50	52	54	56	58	60	62	64	66	68	70	72	74	74	74	74	74	74
5.220 (0.2055)											06	06	06	08	10	12	14	16		28	30	32	34	36	38	40	42	44	46	48	50	52	54	56	58	60	62	64	66	68	70	72	74	74	74	74	74	74
5.230 (0.2059)											06	06	06	08	10	12	14	16	18		30	32	34	36	38	40	42	44	46	48	50	52	54	56	58	60	62	64	66	68	70	72	74	74	74	74	74	74
5.240 (0.2063)											06	06	06	08	10	12	14	16	18		30	32	34	36	38	40	42	44	46	48	50	52	54	56	58	60	62	64	66	68	70	72	74	74	74	74	74	74
5.250 (0.2067)											06	06	06	08	10	12	14	16	18	20		32	34	36	38	40	42	44	46	48	50	52	54	56	58	60	62	64	66	68	70	72	74	74	74	74	74	74
5.260 (0.2071)											06	06	06	08	10	12	14	16	18	20		32	34	36	38	40	42	44	46	48	50	52	54	56	58	60	62	64	66	68	70	72	74	74	74	74	74	74
5.270 (0.2075)											06	06	06	08	10	12	14	16	18	20	22		34	36	38	40	42	44	46	48	50	52	54	56	58	60	62	64	66	68	70	72	74	74	74	74	74	74
5.280 (0.2079)											06	06	06	08	10	12	14	16	18	20	22		34	36	38	40	42	44	46	48	50	52	54	56	58	60	62	64	66	68	70	72	74	74	74	74	74	74
5.290 (0.2083)											06	06	06	08	10	12	14	16	18	20	22	24		36	38	40	42	44	46	48	50	52	54	56	58	60	62	64	66	68	70	72	74	74	74	74	74	74
5.300 (0.2087)											06	06	06	08	10	12	14	16	18	20	22	24		36	38	40	42	44	46	48	50	52	54	56	58	60	62	64	66	68	70	72	74	74	74	74	74	74
5.310 (0.2091)											06	06	06	08	10	12	14	16	18	20	22	24	26		38	40	42	44	46	48	50	52	54	56	58	60	62	64	66	68	70	72	74	74	74	74	74	74
5.320 (0.2094)											06	06	06	08	10	12	14	16	18	20	22	24	26		38	40	42	44	46	48	50	52	54	56	58	60	62	64	66	68	70	72	74	74	74	74	74	74
5.330 (0.2098)											06	06	06	08	10	12	14	16	18	20	22	24	26	28		40	42	44	46	48	50	52	54	56	58	60	62	64	66	68	70	72	74	74	74	74	74	74
5.340 (0.2102)											06	06	06	08	10	12	14	16	18	20	22	24	26	28		40	42	44	46	48	50	52	54	56	58	60	62	64	66	68	70	72	74	74	74	74	74	74
5.350 (0.2106)											08	10	12	14	16	18	20	22	24	26	28	30		42	44	46	48	50	52	54	56	58	60	62	64	66	68	70	72	74	74	74	74	74	74	74	74	
5.360 (0.2110)											08	10	12	14	16	18	20	22	24	26	28	30		42	44	46	48	50	52	54	56	58	60	62	64	66	68	70	72	74	74	74	74	74	74	74	74	
5.370 (0.2114)											10	12	14	16	18	20	22	24	26	28	30	32		44	46	48	50	52	54	56	58	60	62	64	66	68	70	72	74	74	74	74	74	74	74	74	74	
5.380 (0.2118)											10	12	14	16	18	20	22	24	26	28	30	32		44	46	48	50	52	54	56	58	60	62	64	66	68	70	72	74	74	74	74	74	74	74	74	74	
5.390 (0.2122)											12	14	16	18	20	22	24	26	28	30	32	34		46	48	50	52	54	56	58	60	62	64	66	68	70	72	74	74	74	74	74	74	74	74	74	74	
5.400 (0.2126)											12	14	16	18	20	22	24	26	28	30	32	34		46	48	50	52	54	56	58	60	62	64	66	68	70	72	74	74	74	74	74	74	74	74	74	74	
5.410 (0.2130)											14	16	18	20	22	24	26	28	30	32	34	36		48	50	52	54	56	58	60	62	64	66	68	70	72	74	74	74	74	74	74	74	74	74	74	74	
5.420 (0.2134)											14	16	18	20	22	24	26	28	30	32	34	36		48	50	52	54	56	58	60	62	64	66	68	70	72	74	74	74	74	74	74	74	74	74	74	74	
5.430 (0.2138)											16	18	20	22	24	26	28	30	32	34	36	38		50	52	54	56	58	60	62	64	66	68	70	72	74	74	74	74	74	74	74	74	74	74	74	74	
5.440 (0.2142)											16	18	20	22	24	26	28	30	32	34	36	38		50	52	54	56	58	60	62	64	66	68	70	72	74	74	74	74	74	74	74	74	74	74	74	74	
5.450 (0.2146)											18	20	22	24	26	28	30	32	34	36	38	40		52	54	56	58	60	62	64	66	68	70	72	74	74	74	74	74	74	74	74	74	74	74	74	74	
5.460 (0.2150)																																																

Exhaust valve clearance (cold):
0.25 to 0.35 mm (0.010 to 0.014 in.)

EXAMPLE:

A 5.340 mm (0.2102 in.) lifter is installed, and the measured clearance is 0.440 mm (0.0173 in.). Replace the 5.340 mm (0.2102 in.) lifter with a new No. 48 lifter.

New Shim Thickness

Shim No.	Thickness	Shim No.	Thickness	Shim No.	Thickness
06	5.060 (0.1992)	30	5.300 (0.2087)	54	5.540 (0.2181)
08	5.080 (0.2000)	32	5.320 (0.2094)	56	5.560 (0.2189)
10	5.100 (0.2008)	34	5.340 (0.2102)	58	5.580 (0.2197)
12	5.120 (0.2016)	36	5.360 (0.2110)	60	5.600 (0.2205)
14	5.140 (0.2024)	38	5.380 (0.2118)	62	5.620 (0.2213)
16	5.160 (0.2031)	40	5.400 (0.2126)	64	5.640 (0.2220)
18	5.180 (0.2039)	42	5.420 (0.2134)	66	5.660 (0.2228)
20	5.200 (0.2047)	44	5.440 (0.2142)	68	5.680 (0.2236)
22	5.220 (0.2055)	46	5.460 (0.2150)	70	5.700 (0.2244)
24	5.240 (0.2063)	48	5.480 (0.2157)	72	5.720 (0.2252)
26	5.260 (0.2071)	50	5.500 (0.2165)	74	5.740 (0.2260)
28	5.280 (0.2079)	52	5.520 (0.2173)		

EM

- (r) Install the selected valve lifter.
- (s) Apply a light coat of engine oil to the camshaft and camshaft journals.
- (t) Install the chain onto the camshaft timing gear with the paint mark and the timing mark aligned, as shown in the illustration.

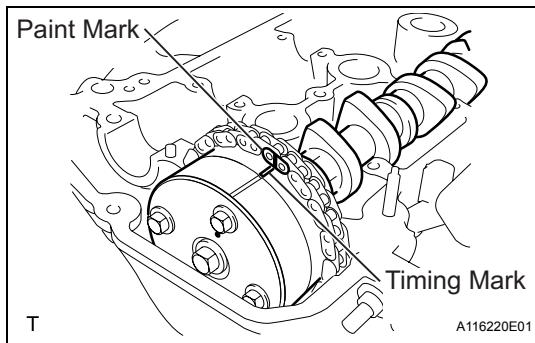

- (u) Examine the front marks and the numbers on camshaft bearing cap No. 2 and check that the sequence is as shown in the illustration. Then uniformly tighten the bolts in several steps in the sequence shown in the illustration.

Torque: 13 N*m (129 kgf*cm, 9.4 ft.*lbf)

NOTICE:

Tighten the bolts uniformly while keeping the camshaft level.

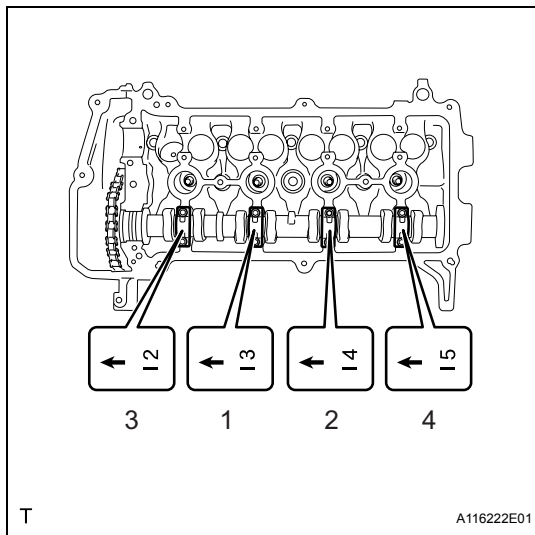

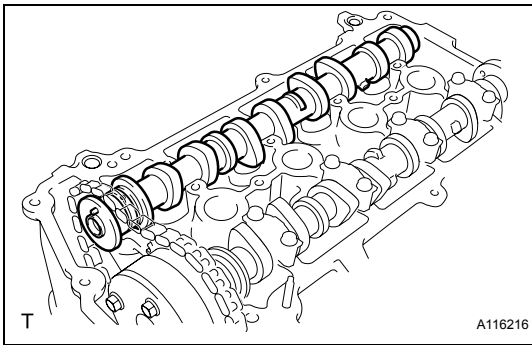

(v) Install camshaft No. 2.

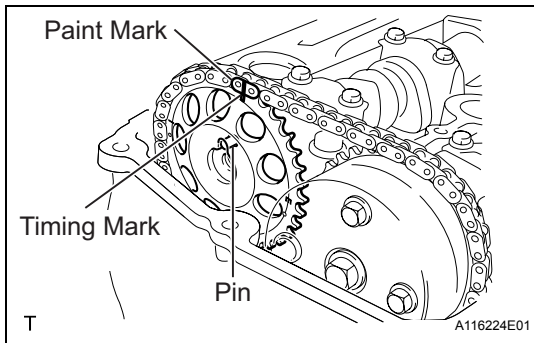

- (w) Hold the chain, and align the timing mark on the camshaft timing sprocket with the paint mark of the chain.
- (x) Align the alignment pin hole in the camshaft timing sprocket with the alignment pin of the camshaft, and install the sprocket onto the camshaft.

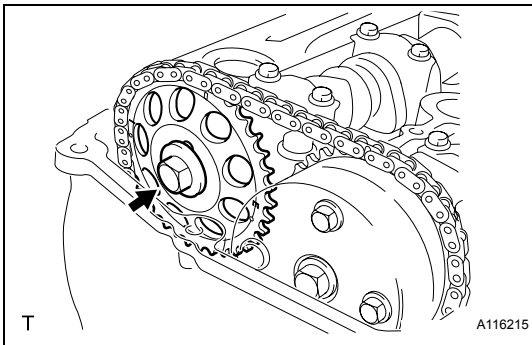

(y) Provisionally install the flange bolt.

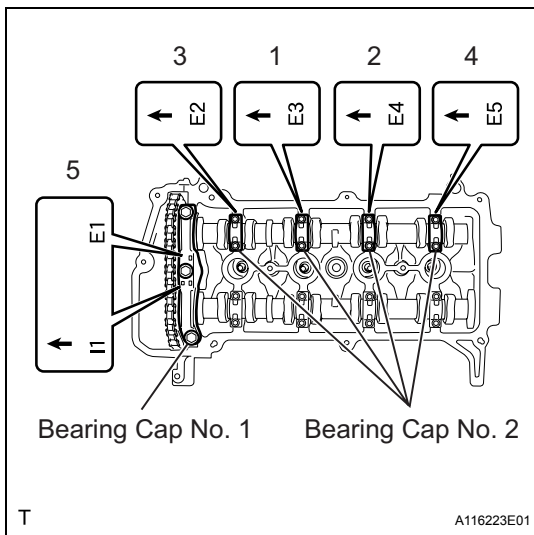

(z) Examine the front marks and the numbers of camshaft bearing cap No. 1 and camshaft bearing cap No. 2 and check that the sequence is as shown in the illustration. Then uniformly tighten the bolts, in several steps, in the sequence shown in the illustration.

Torque: 13 N*m (129 kgf*cm, 9.4 ft.*lbf) for bearing cap No. 2
23 N*m (235 kgf*cm, 17 ft.*lbf) for bearing cap No. 1

NOTICE:
Tighten the bolts uniformly while keeping the camshaft level.

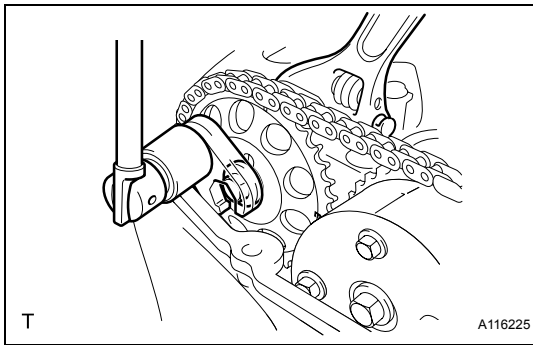

- (aa) Using a wrench, hold the hexagonal lobe of camshaft No. 2, and install the flange bolt.

Torque: 64 N*m (653 kgf*cm, 47 ft.*lbf)
SST 09023-38400

- (ab) Remove the bar from the timing chain tensioner.

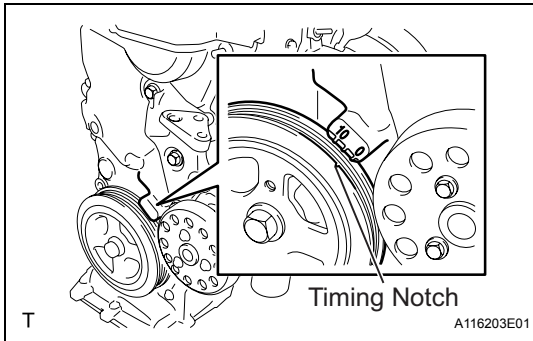

- (ac) Turn the crankshaft damper, and align its timing notch with the timing mark "0" of the oil pump.

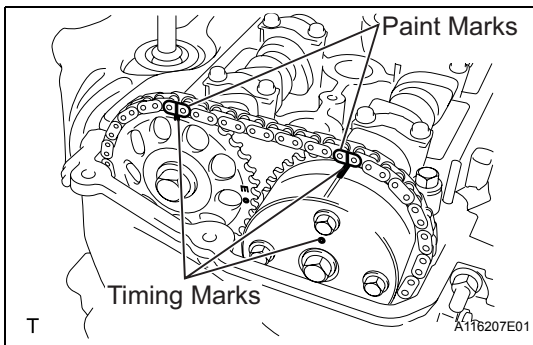

- (ad) Check that all the pairs of timing marks are aligned.

- (ae) Apply adhesive to the end 2 or 3 threads of the screw plug.

Adhesive:

Toyota Genuine Adhesive 1324, Three Bond 1324 or Equivalent

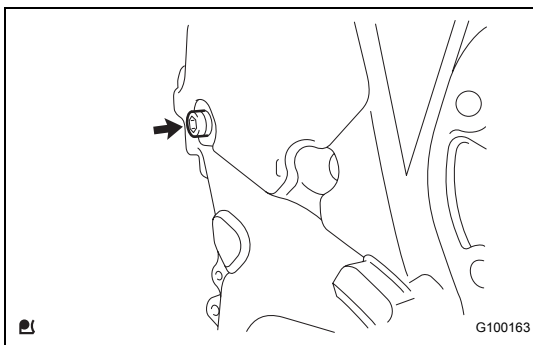

- (af) Using an 8 mm hexagon wrench, install the screw plug.

Torque: 15 N*m (153 kgf*cm, 11 ft.*lbf)

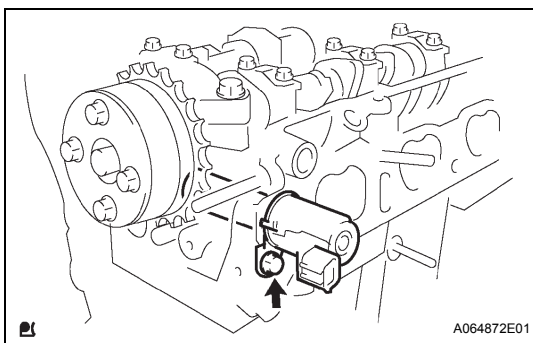

41. INSTALL CAMSHAFT TIMING OIL CONTROL VALVE ASSEMBLY

- (a) Apply a light coat of engine oil to a new O-ring, and install it onto the camshaft timing oil control valve.

- (b) Install the camshaft timing oil control valve with the bolt.

Torque: 7.5 N*m (76 kgf*cm, 66 in.*lbf)

NOTICE:

Do not twist the O-ring.

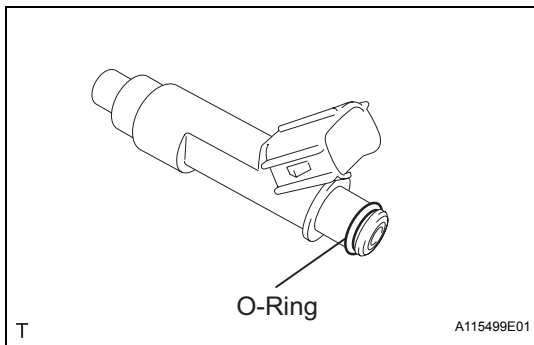
**42. INSTALL FUEL INJECTOR ASSEMBLY**

- (a) Apply a light coat of gasoline or spindle oil to new O-rings, then install one onto each fuel injector.
- (b) Apply a light coat of gasoline or spindle oil to the contact surfaces of the fuel delivery pipe and the O-ring of the fuel injector.

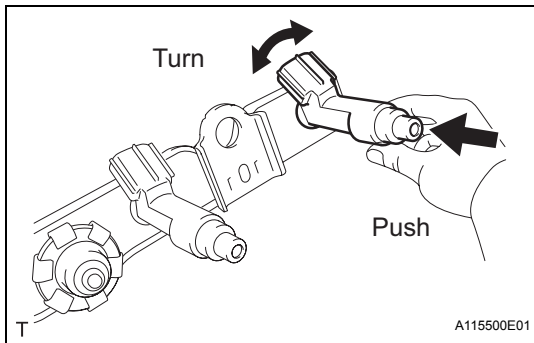

- (c) While turning the fuel injector left and right, install it onto the fuel delivery pipe.

NOTICE:

- Do not twist the O-ring.
- After installing the fuel injectors, check that they turn smoothly. If not, replace the O-ring with a new one.

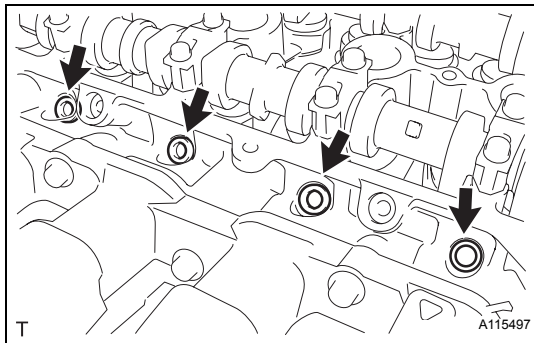
**43. INSTALL INJECTOR VIBRATION INSULATOR**

- (a) Install 4 new injector vibration insulators onto the cylinder head.

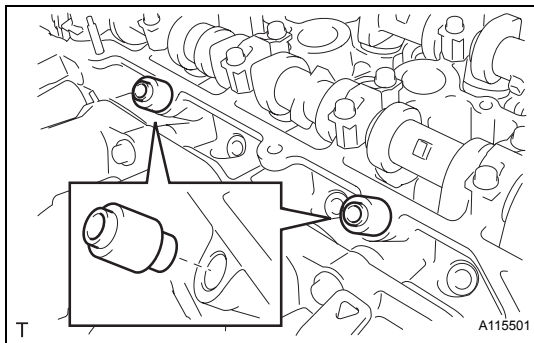
**44. INSTALL DELIVERY PIPE NO. 1 SPACER**

- (a) Install the 2 delivery pipe No. 1 spacers onto the cylinder head.

NOTICE:

Install delivery pipe No. 1 spacer in the correct direction.

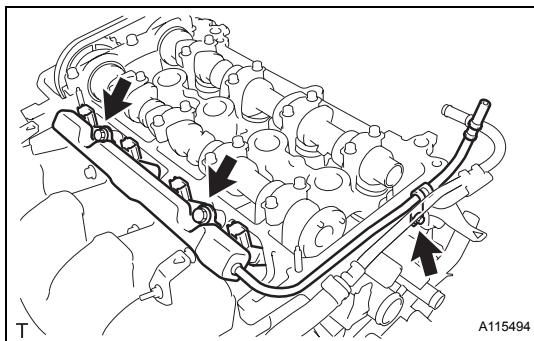
**45. INSTALL FUEL DELIVERY PIPE SUB-ASSEMBLY**

- (a) Provisionally install the fuel delivery pipe sub-assembly and 4 fuel injectors with the 3 bolts.

NOTICE:

- Do not drop the fuel injectors when installing the fuel delivery pipe sub-assembly.
- Check that the fuel injectors rotate smoothly after installing the fuel delivery pipe sub-assembly.

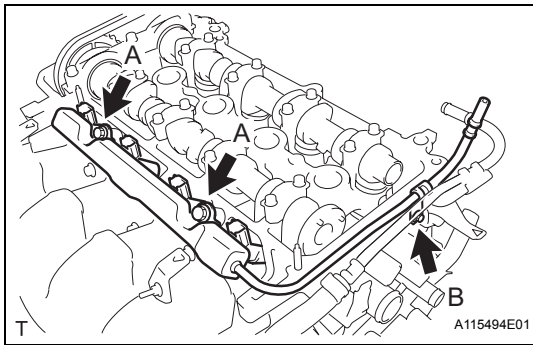

- (b) Tighten the 3 bolts to the specified torque.
Torque: 19 N*m (194 kgf*cm, 14 ft.*lbf) for bolt A
9.0 N*m (92 kgf*cm, 80 in.*lbf) for bolt B

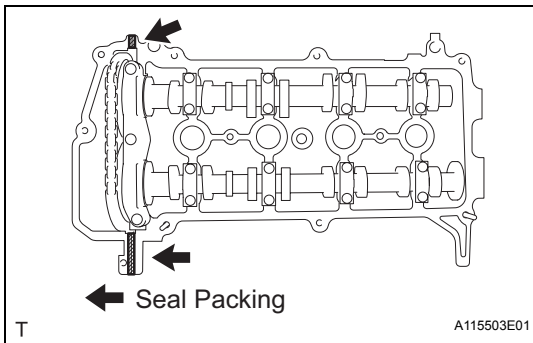

46. INSTALL CYLINDER HEAD COVER SUB-ASSEMBLY

- (a) Install the gasket onto the cylinder head cover.
 (b) Apply seal packing to the cylinder head, as shown in the illustration.

Seal Packing:

Toyota Genuine Seal Packing Black, Three Bond 1207B or Equivalent

NOTICE:

- Remove any oil from the contact surface.
- Install the cylinder head cover sub-assembly within 3 minutes of applying the seal packing.
- Do not start engine for at least 2 hours after the installation.

- (c) Install the cylinder head cover sub-assembly with the 9 bolts, 2 nuts and 2 seal washers.

- (d) Tighten the 9 bolts and 2 nuts in the sequence shown in the illustration.

Torque: 10 N*m (102 kgf*cm, 7.0 ft.*lbf)

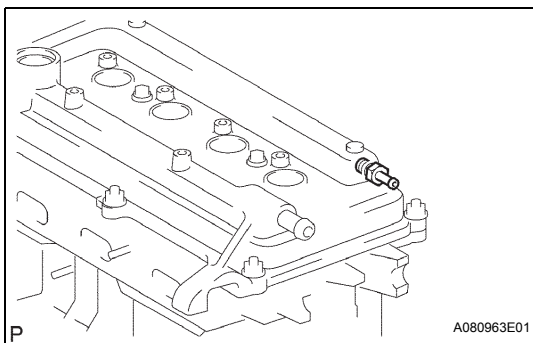
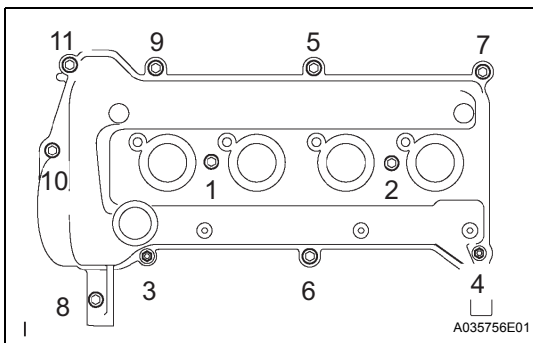

47. INSTALL VENTILATION VALVE SUB-ASSEMBLY

- (a) Install the ventilation valve onto the cylinder head cover.

Torque: 27 N*m (275 kgf*cm, 20 ft.*lbf)

48. INSTALL OIL LEVEL GAUGE GUIDE

- (a) Apply engine oil to a new O-ring.
 (b) Install the oil level gauge guide with the bolt.

Torque: 9.0 N*m (92 kgf*cm, 80 in.*lbf)

49. INSTALL CRANKSHAFT POSITION SENSOR

- (a) Apply a light coat of engine oil to the O-ring on the crankshaft position sensor.

NOTICE:

If the O-ring is damaged, replace the crankshaft position sensor.

- (b) Install the crankshaft position sensor with the bolt.

Torque: 7.5 N*m (76 kgf*cm, 66 in.*lbf)

50. INSTALL OIL FILLER CAP GASKET

- (a) Install the oil filler cap gasket onto the oil filler cap.

51. INSTALL OIL FILLER CAP SUB-ASSEMBLY

- (a) Install the oil filler cap onto the cylinder head cover.

52. INSTALL THERMOSTAT

- (a) Install a new gasket onto the thermostat.
 (b) Install the thermostat with the jiggle valve facing upward.

HINT:

The jiggle valve may be set within 10° either side as shown in the illustration.

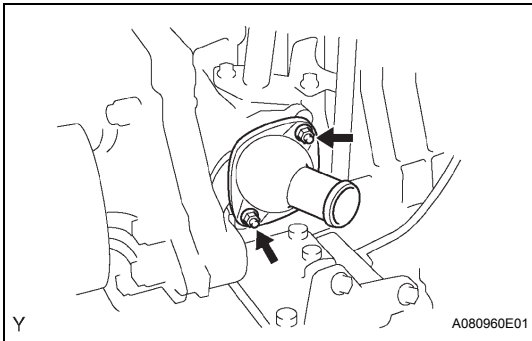
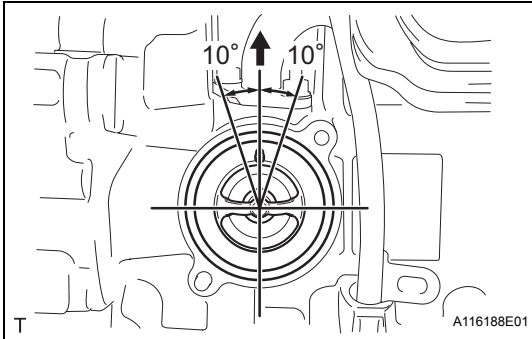
**53. INSTALL WATER INLET**

- (a) Install the water inlet with the 2 nuts.
Torque: 9.0 N*m (92 kgf*cm, 80 in.*lbf)

54. INSTALL ENGINE COOLANT TEMPERATURE SENSOR

- (a) Provisionally install the engine coolant temperature sensor through a new gasket.

- (b) Using SST, tighten the engine coolant temperature sensor.

SST 09817-33190

Torque: 20 N*m (204 kgf*cm, 15 ft.*lbf)

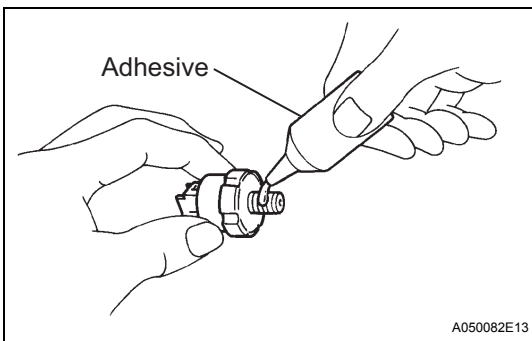
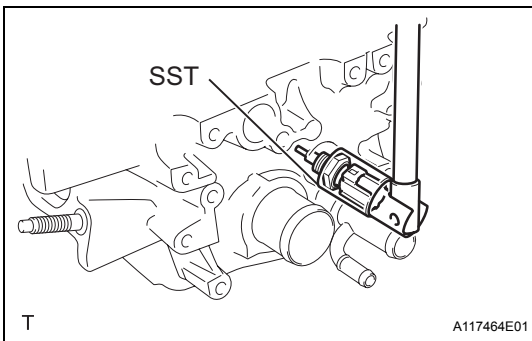
**55. INSTALL ENGINE OIL PRESSURE SWITCH ASSEMBLY**

- (a) Apply adhesive to the end 2 or 3 threads of the oil pressure switch.

Adhesive:

Toyota Genuine Adhesive 1324, Three Bond 1324 or Equivalent

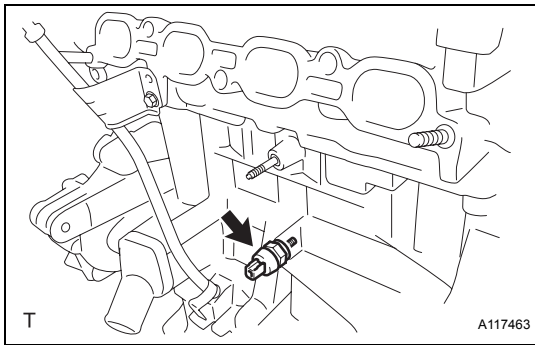

- (b) Using a 24 mm deep socket wrench, install the oil pressure switch.
Torque: 15 N*m (153 kgf*cm, 11 ft.*lbf)

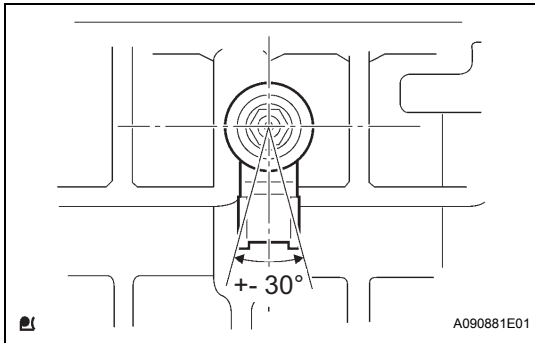

56. INSTALL KNOCK SENSOR

- (a) Install the knock sensor with the nut as shown in the illustration.
Torque: 20 N*m (204 kgf*cm, 15 ft.*lbf)

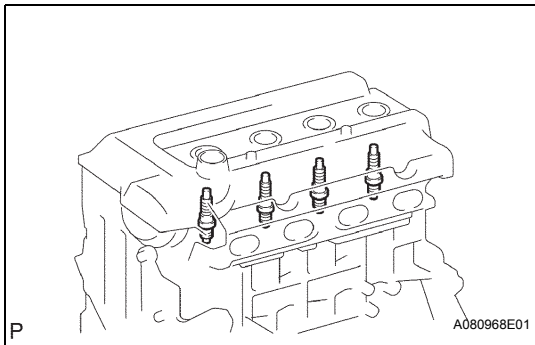

57. INSTALL SPARK PLUG

- (a) Using a spark plug wrench, install the spark plugs.
Torque: 18 N*m (184 kgf*cm, 13 ft.*lbf)

ENGINE

ON-VEHICLE INSPECTION

1. **INSPECT ENGINE COOLANT** (See page [CO-1](#))
2. **INSPECT ENGINE OIL** (See page [LU-1](#))
3. **INSPECT BATTERY** (See page [CH-4](#))
4. **INSPECT AIR CLEANER FILTER ELEMENT SUB-ASSEMBLY**
 - (a) Remove the air cleaner filter element sub-assembly.
 - (b) Visually check that there is no dirt, blockage, or damage to the air cleaner filter element.

HINT:

- If there is any dirt or a blockage in the air cleaner filter element, clean it with compressed air.
- If any dirt or a blockage remains even after cleaning the air cleaner filter element with compressed air, replace it.

5. **INSPECT SPARK PLUG** (See page [IG-5](#))

6. **INSPECT IGNITION TIMING**

- (a) When using an intelligent tester:

- (1) Warm up and stop the engine.
- (2) Connect the intelligent tester to the DLC3.
- (3) Turn the ignition switch ON.
- (4) Select the following menu items:
DIAGNOSIS / ENHANCED OBD II/ ACTIVE TEST / TC (TE1) / ON.

HINT:

Refer to the intelligent tester operator's manual for further details.

- (5) Inspect the ignition timing during idling.

Ignition timing:

8 to 12 degrees BTDC

NOTICE:

- Turn all the electrical systems and the A/C off.
- Inspect the ignition timing with the cooling fan off.
- When checking the ignition timing, shift the transmission to the neutral position.

- (6) Select the following menu items: TC (TE1) / OFF.

- (7) Turn the ignition switch OFF.

- (8) Disconnect the intelligent tester from the DLC3.

- (b) When not using an intelligent tester:

- (1) Remove cylinder head cover No. 2 (see page [IG-9](#)).

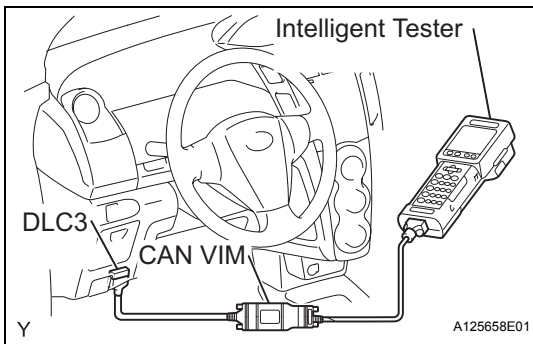

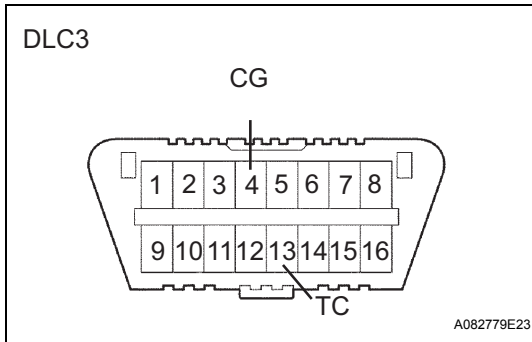
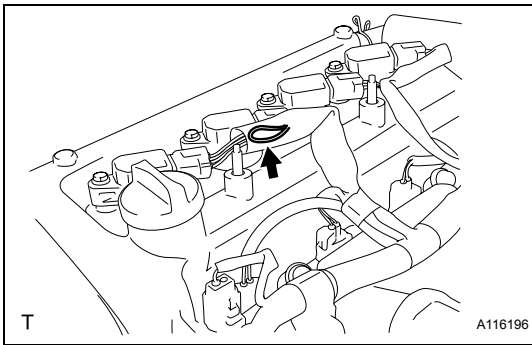

- (2) Pull out the wire harness (brown) shown in the illustration.

NOTICE:

After checking, wrap the wire harness with tape.

- (3) Warm up and stop the engine.
- (4) Connect the clip of the timing light to the wire harness.

NOTICE:

Use a timing light that detects the first signal.

- (5) Turn the ignition switch ON.
- (6) Using SST, connect terminals 13 (TC) and 4 (CG) of the DLC3.

SST 09843-18040**NOTICE:**

Examine the terminal numbers before connecting them. Connecting the wrong terminals could damage the engine.

- (7) Inspect the ignition timing during idling.

Ignition timing:

8 to 12 degrees BTDC

NOTICE:

- Turn all the electrical systems and the A/C off.
- Inspect the ignition timing with the cooling fan off.
- When checking the ignition timing, shift the transmission to the neutral position.

- (8) Disconnect terminals 13 (TC) and 4 (CG) of the DLC3.

- (9) Turn the ignition switch OFF.

- (10) Remove the timing light.

- (11) Install cylinder head cover No. 2 (see page IG-10).

7. INSPECT ENGINE IDLING SPEED

- (a) When using an intelligent tester:

- (1) Warm up and stop the engine.

- (2) Connect the intelligent tester to the DLC3.

- (3) Turn the ignition switch ON.

- (4) Select the following menu items:
DIAGNOSIS / ENHANCED OBD II/ DATA LIST / PRIMARY / ENGINE SPD.

HINT:

Refer to the intelligent tester operator's manual for further details.

- (5) Inspect the engine idling speed.

Idling speed:

550 to 650 rpm for manual transaxle

650 to 750 rpm for automatic transaxle

NOTICE:

- Turn all the electrical systems and the A/C off.

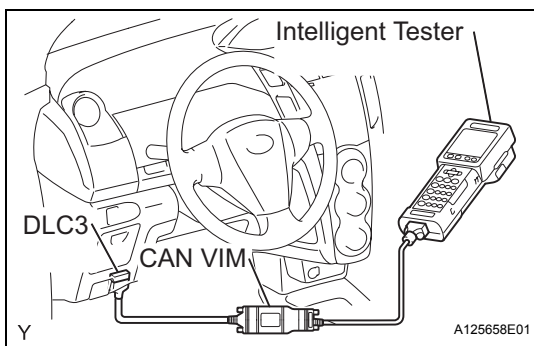

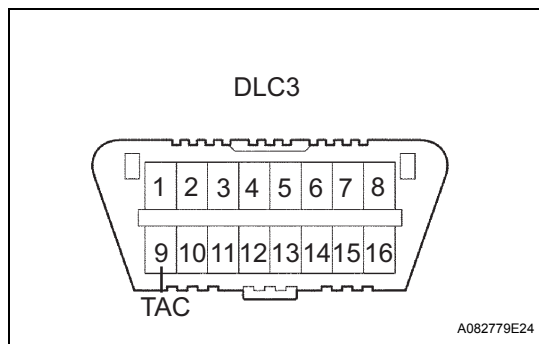

- Inspect the idling speed with the cooling fan off.
 - When checking the idling speed, shift the transmission to either the neutral position or the parking position.
- (6) Turn the ignition switch OFF.
 - (7) Disconnect the intelligent tester from the DLC3.
- (b) When not using an intelligent tester.
- (1) Warm up and stop the engine.
 - (2) Install SST to terminal 9 (TAC) of the DLC3, then connect a tachometer.
SST 09843-18040
NOTICE:
Examine the terminal numbers before connecting them. Connecting the wrong terminals could damage the engine.
 - (3) Turn the ignition switch ON.
 - (4) Inspect the engine idling speed.
Idling speed:
550 to 650 rpm for manual transaxle
650 to 750 rpm for automatic transaxle
 - (5) Turn the ignition switch OFF.
 - (6) Disconnect the tachometer.
 - (7) Remove SST from terminal 9 (TAC).

EM

8. INSPECT COMPRESSION

- (a) Warm up and stop the engine.
- (b) Remove cylinder head cover No. 2 (see page IG-9).
- (c) Remove the 4 ignition coils (see page IG-9).
- (d) Remove the 4 spark plugs.
- (e) Disconnect the 4 fuel injector connectors.
- (f) Inspect the cylinder compression pressure.
 - (1) Insert a compression gauge into the spark plug hole.
 - (2) Fully open the throttle.
 - (3) While cranking the engine, measure the compression pressure.

Compression:

1,471kPa (15.0 kgf/cm², 213 psi)

Minimum pressure:

1,079 kPa (11.0 kgf/cm², 156 psi)

Difference between each cylinder:

98 kPa (1.0 kgf/cm², 14 psi) or less

NOTICE:

- Use a fully-charged battery so the engine speed can be increased to 250 rpm or more.
- Inspect the other cylinders in the same way.
- Measure the compression in as short a time as possible.

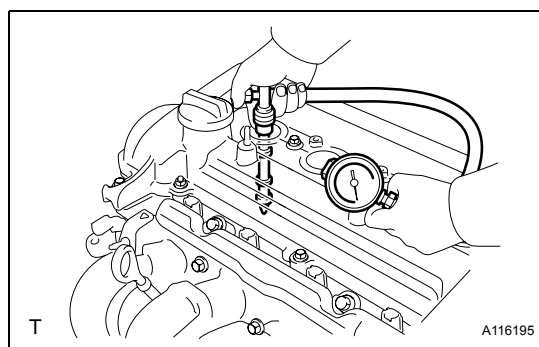

- (4) If the cylinder compression is low, pour a light coat of engine oil into the cylinder through the spark plug hole, then inspect it again.

HINT:

- If adding oil increases the compression, the piston rings and/or cylinder bore may be worn or damaged.
- If the pressure stays low, the valve may be stuck or seated improperly, or there may be leakage from the gasket.

(g) Connect the 4 fuel injector connectors.

(h) Install the 4 spark plugs.

Torque: 18 N*m (184 kgf*cm, 13 ft.*lbf)

(i) Install the 4 ignition coils (see page [IG-9](#)).

(j) Install cylinder head cover No. 2 (see page [IG-10](#)).

9. INSPECT CO/HC

(a) Start the engine.

(b) Run the engine at 2,500 rpm for approximately 180 seconds.

(c) Insert the CO/HC meter testing probe at least 40 cm (1.3 ft) into the tailpipe while idling.

(d) Check the CO/HC concentration during idling and when running at 2,500 rpm.

HINT:

When doing the 2 mode (with the engine idling/running at 2,500 rpm) test, the measuring procedures are determined by applicable local regulations.

If the CO/HC concentration does not comply with the regulations, troubleshoot in the order given below.

- (1) Check the heated oxygen sensor operation (see page [ES-276](#)).
- (2) See the table below for possible causes, then inspect the applicable parts and repair them if necessary.

CO	HC	Problems	Possible Causes
Normal	High	Rough idling	<ol style="list-style-type: none"> 1. Faulty ignition: <ul style="list-style-type: none"> – Incorrect timing – Fouled, shorted or improperly gapped plugs 2. Incorrect valve clearance 3. Leakage from intake and exhaust valves 4. Leakage from cylinders
Low	High	Rough idling (Fluctuating HC reading)	<ol style="list-style-type: none"> 1. Vacuum leaks: <ul style="list-style-type: none"> – PCV hoses – Intake manifold – Throttle body – Brake booster line 2. Lean mixture causing misfire
High	High	Rough idling (Black smoke from exhaust)	<ol style="list-style-type: none"> 1. Restricted air cleaner filter element 2. Plugged PCV valve 3. Faulty EFI systems: <ul style="list-style-type: none"> – Faulty pressure regulator – Faulty engine coolant temperature sensor – Faulty mass air flow meter – Faulty ECM – Faulty injectors – Throttle body

DRIVE BELT COMPONENTS

EM

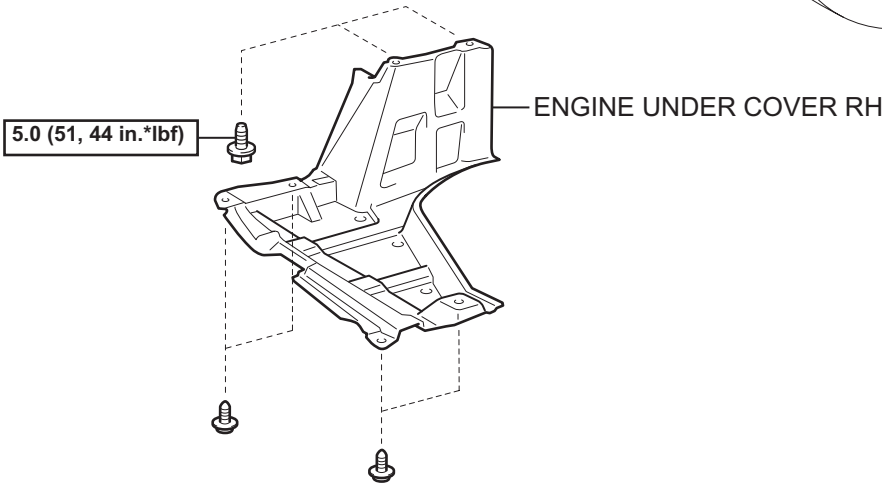
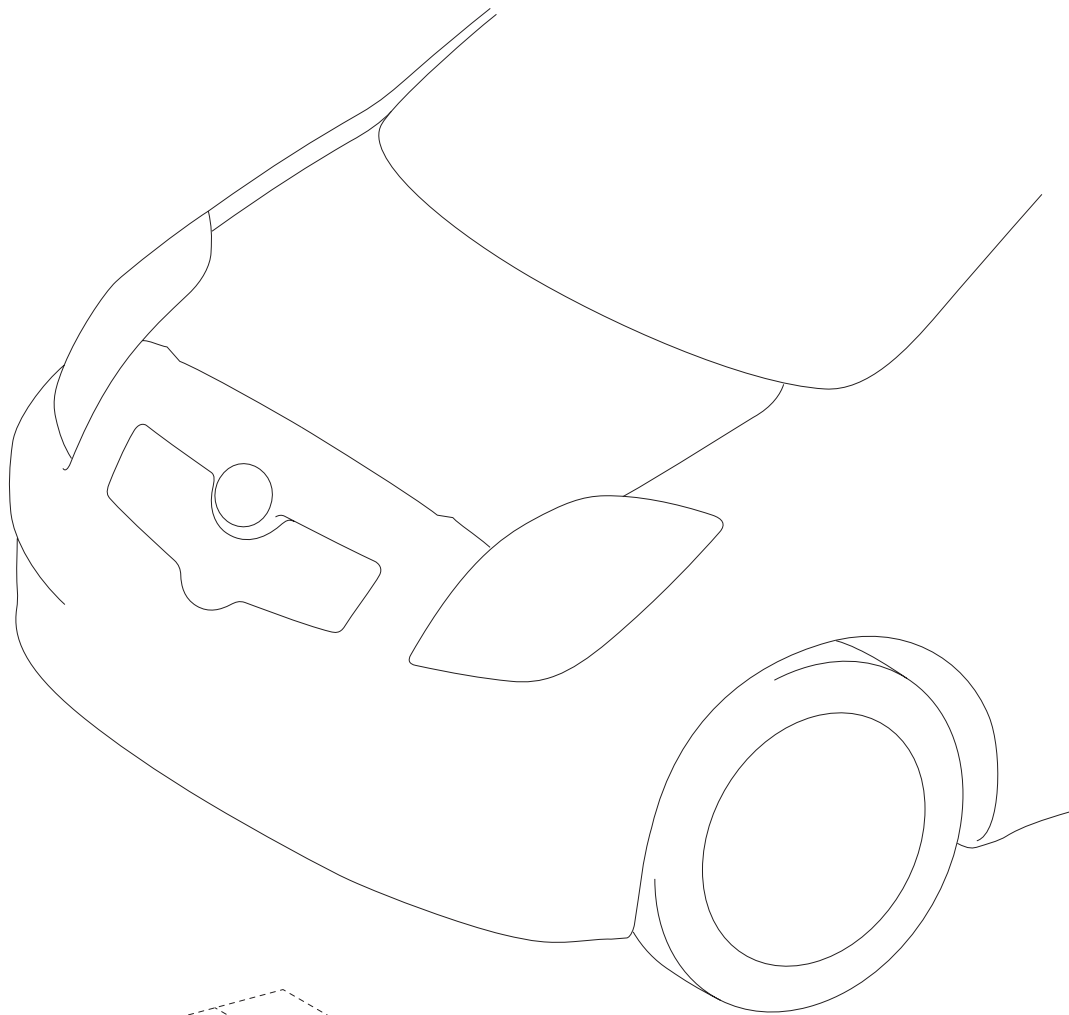

N*m (kgf*cm, ft.*lbf): Specified torque

EM

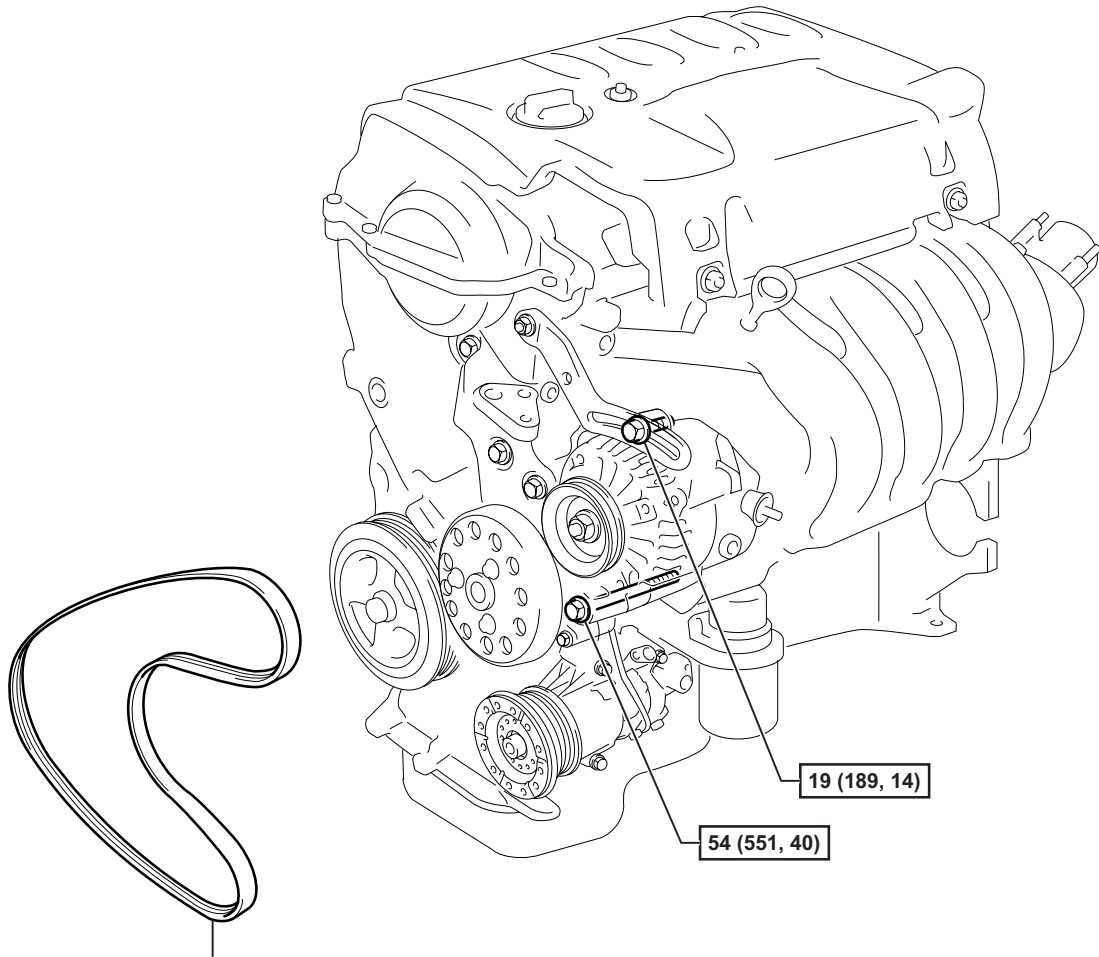

FAN AND GENERATOR V BELT

N*m (kgf*cm, ft.*lbf) : Specified torque

T

REMOVAL

1. REMOVE ENGINE UNDER COVER RH
2. REMOVE FAN AND GENERATOR V BELT
 - (a) Loosen bolts A and B.
 - (b) Release the fan and generator V belt tension and remove the fan and generator V belt.

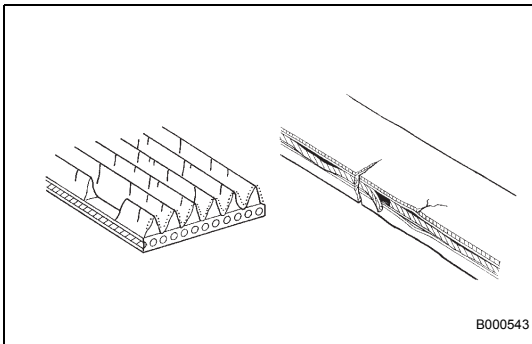
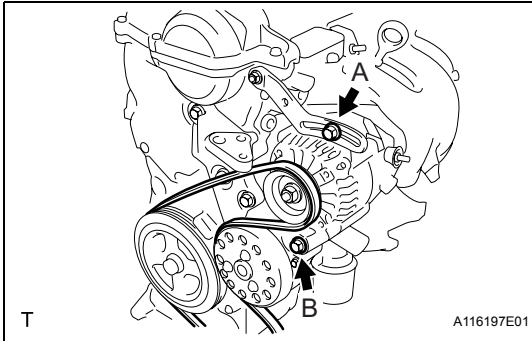

INSPECTION

1. INSPECT FAN AND GENERATOR V BELT
 - (a) Visually check the belt for excessive wear, frayed cords etc. If any defects are found, replace the belt.
HINT:
 - If any defects are found, replace the belt.
 - Cracks on the rib side of a belt are considered acceptable. If the belt has pieces missing from the ribs, it should be replaced.

INSTALLATION

1. INSTALL FAN AND GENERATOR V BELT

- (a) Provisionally install the fan and generator V belt onto each pulley.

NOTICE:

Make sure that the V-belt is securely fitted into the rib groove of the pulley.

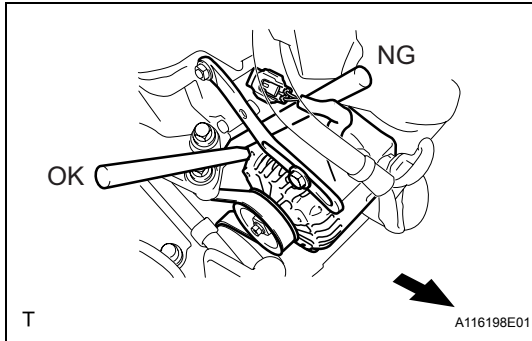

2. ADJUST FAN AND GENERATOR V BELT

- (a) Insert an adjusting bar between the engine mounting bracket and generator assembly. Push the adjusting bar toward the vehicle front to adjust the generator V belt tension.

NOTICE:

Do not insert the adjusting bar between the camshaft timing oil control valve assembly and generator assembly. It could damage the camshaft timing oil control valve assembly.

- (b) First tighten bolt A, then tighten bolt B.

**Torque: 19 N*m (189 kgf*cm, 14 ft.*lbf) for bolt A
54 N*m (551 kgf*cm, 40 ft.*lbf) for bolt B**

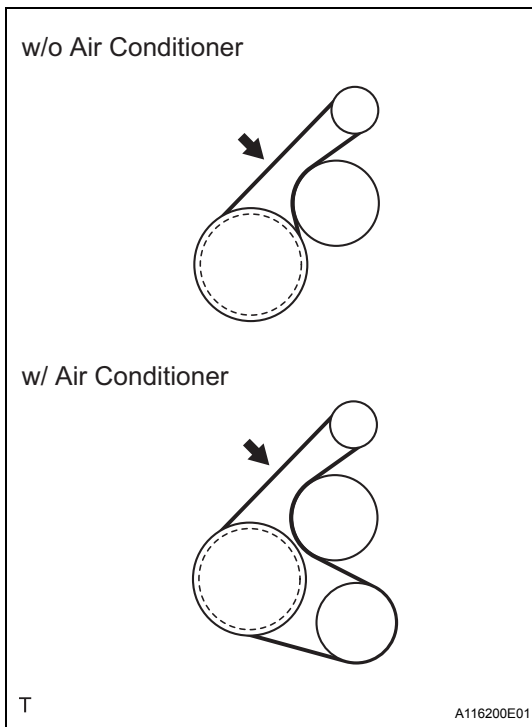
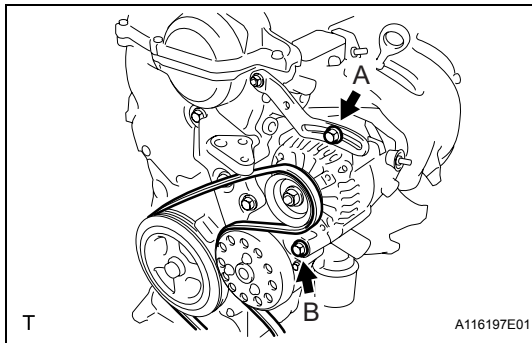

3. INSPECT FAN AND GENERATOR V BELT

- (a) Check the V belt deflection and tension.

Deflection

Item	Specified Condition
New belt	7.0 to 8.5 mm (0.28 to 0.33 in)
Used belt	11 to 13 mm (0.43 to 0.51 in)

Tension

Item	Specified Condition
New belt	539 to 637 N (55 to 65 kg, 121 to 143 ld)
Used belt	245 to 392 N (25 to 40 kg, 55 to 88 ld)

If the belt deflection is not as specified, adjust it.

HINT:

- Check the V belt deflection at the specified point.
- Check the drive belt deflection at the specified point.
- When installing a new belt, set its tension to the specified value.
- When inspecting a belt which has been used for over 5 minutes, apply the used belt specifications.

- When reinstalling a belt which has been used for over 5 minutes, adjust its deflection and tension to the intermediate values of each used belt specification.
- V-ribbed belt tension and deflection should be checked after 2 revolutions of engine cranking.
- When using a belt tension gauge, confirm its accuracy by using a master gauge first.

4. INSTALL ENGINE UNDER COVER RH

VALVE CLEARANCE

ADJUSTMENT

1. DISCONNECT CABLE FROM NEGATIVE BATTERY TERMINAL
2. REMOVE ENGINE UNDER COVER RH
3. REMOVE CYLINDER HEAD COVER NO. 2 (See page [IG-9](#))
4. REMOVE IGNITION COIL NO. 1 (See page [IG-9](#))
5. DISCONNECT VENTILATION HOSE (See page [FU-13](#))
6. DISCONNECT VENTILATION HOSE NO. 2 (See page [FU-13](#))
7. REMOVE CYLINDER HEAD COVER SUB-ASSEMBLY (See page [FU-13](#))
8. INSPECT VALVE CLEARANCE

HINT:

Inspect the valve clearance when the engine is cold.

- (a) Set the No. 1 cylinder to TDC/compression.
 - (1) Turn the crankshaft damper and align its timing notch with the timing mark "0" of the oil pump.

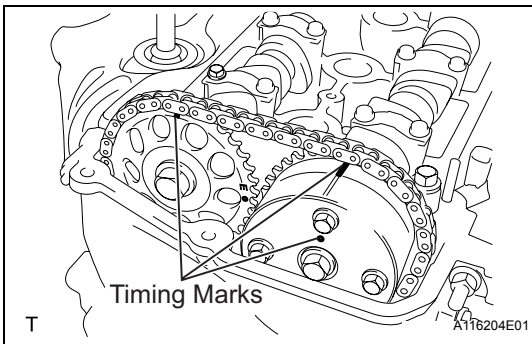
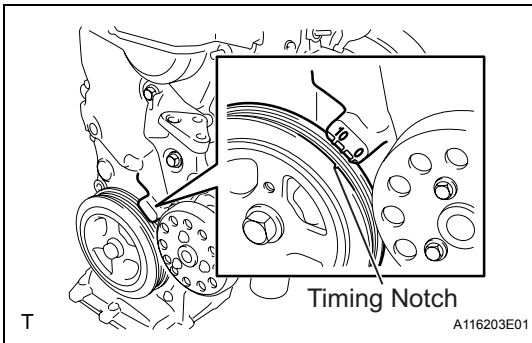

- (2) Check that both timing marks on the camshaft timing sprocket and camshaft timing gear are facing upward, as shown in the illustration.

HINT:

If not, turn the crankshaft 1 complete revolution (360°) and align the marks as above.

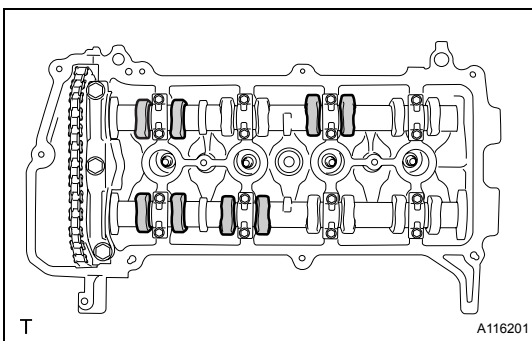

- (b) Check the valves indicated in the illustration.
 - (1) Using a feeler gauge, measure the clearance between the valve lifter and camshaft.

Valve clearance (cold):

for intake:

0.15 to 0.25 mm (0.006 to 0.010 in.)

for exhaust:

0.25 to 0.35 mm (0.010 to 0.014 in.)

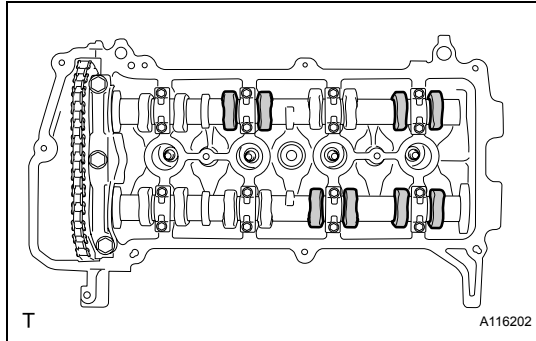

- (2) Record any out-of-specification valve clearance measurements. They will be used later to determine the required replacement adjusting shim.
- (c) Turn the crankshaft 1 complete revolution (360°) and align its timing notch with the timing mark "0" of the oil pump.

- (d) Check the valves indicated in the illustration.
 - (1) Using a feeler gauge, measure the clearance between the valve lifter and camshaft.

Valve clearance (cold):

for intake:

0.15 to 0.25 mm (0.006 to 0.010 in.)

for exhaust:

0.25 to 0.35 mm (0.010 to 0.014 in.)

- (2) Record any out-of-specification valve clearance measurements. They will be used later to determine the required replacement adjusting shim.

9. ADJUST VALVE CLEARANCE

NOTICE:

When rotating the camshaft with the timing chain removed, rotate the crankshaft damper counterclockwise 40° from the TDC and align its timing notch with the matchmark of the timing chain cover to prevent the pistons from coming into contact with the valves.

- (a) Remove the fan and generator V belt (See page [EM-7](#)).
- (b) Remove the engine mounting insulator sub-assembly RH (See page [LU-17](#)).
- (c) Set the No. 1 cylinder to TDC/compression.
 - (1) Turn the crankshaft damper and align its timing notch with the timing mark "0" of the oil pump.

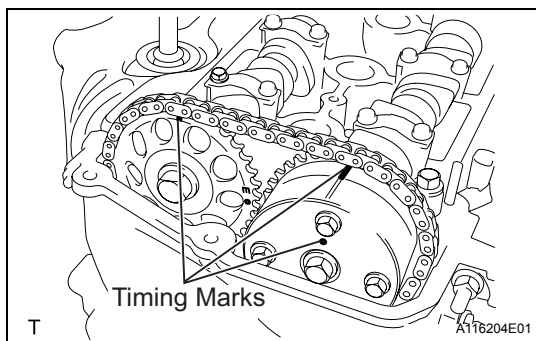
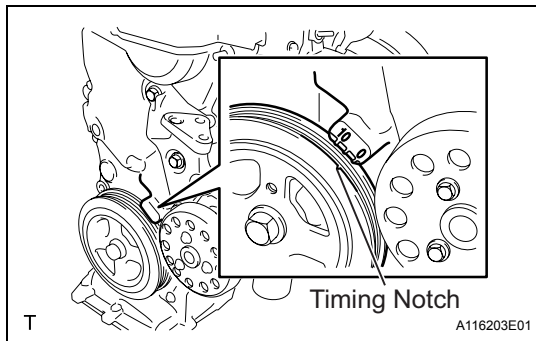
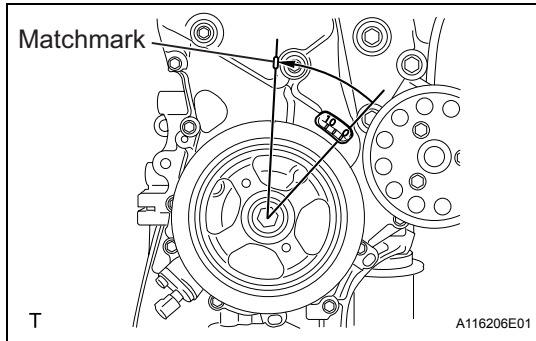

- (2) Check that both timing marks on the camshaft timing sprocket and camshaft timing gear are facing upward, as shown in the illustration.

HINT:

If not, turn the crankshaft 1 complete revolution (360°) and align the marks as above.

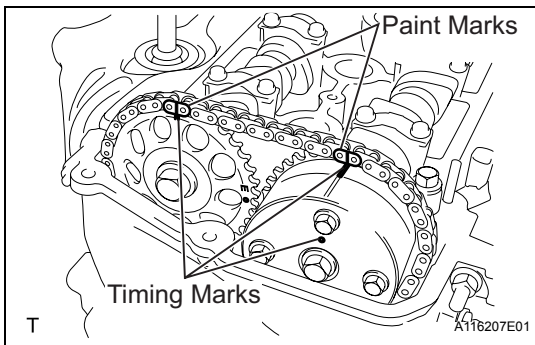

- (d) Place paint marks on the chain in the places where the timing marks of the camshaft timing sprocket and the camshaft timing gear are located.

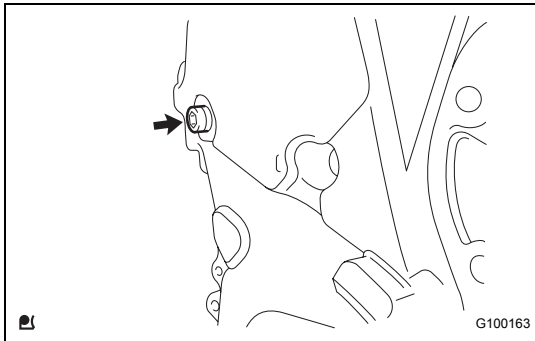

- (e) Using an 8 mm hexagon wrench, remove the screw plug.

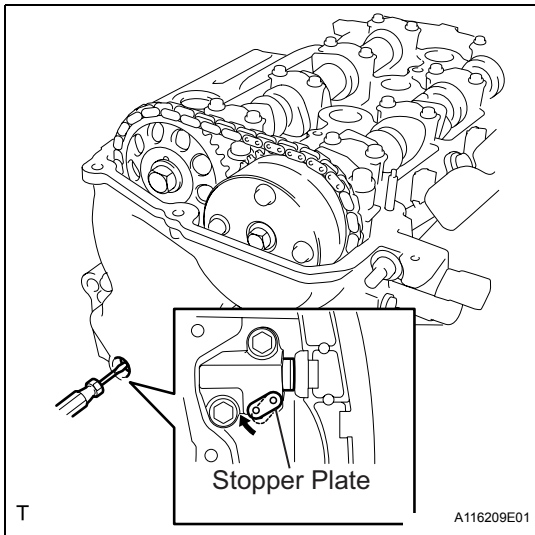

- (f) Insert a screwdriver into the service hole in the chain tensioner to pull the stopper plate of the chain tensioner upward.

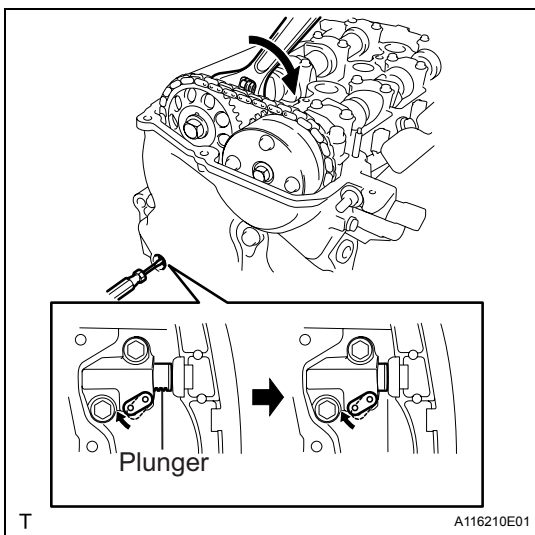

- (g) Using a wrench, rotate camshaft No. 2 clockwise to push in the plunger of the chain tensioner.

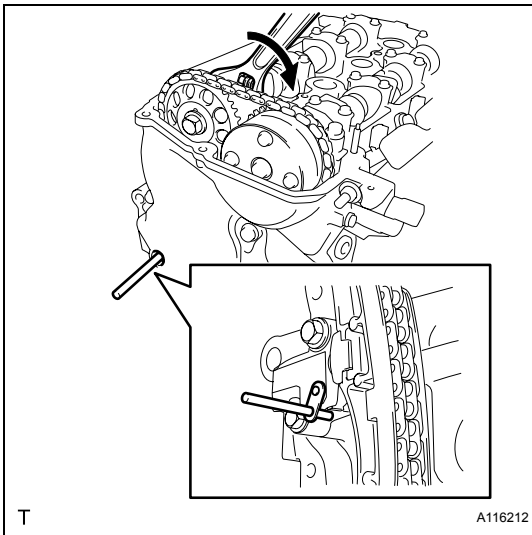

- (h) Remove the screwdriver from the service hole, then align the hole in the stopper plate with the service hole and insert a 3 mm (0.12 in.) diameter bar into the holes to hold the stopper plate.

HINT:

- Fix the stopper plate using the bar while rotating the camshaft right and left slightly.
- Hold the bar with tape so that the bar does not come off.

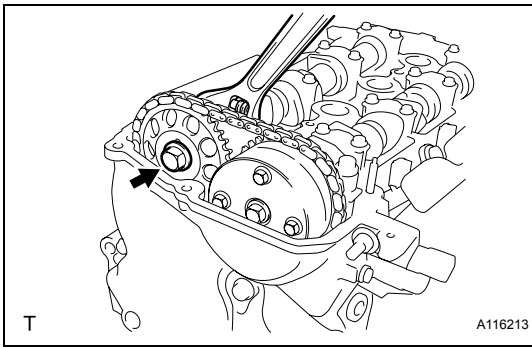

- (i) Using a wrench, hold the hexagonal lobe of camshaft No. 2 and remove the fringe bolt.

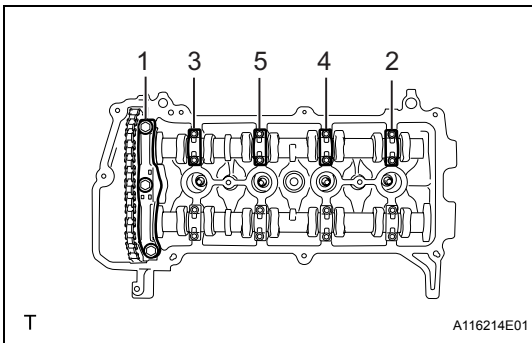

- (j) Using several steps, loosen and remove the 11 bearing cap bolts uniformly in the sequence shown in the illustration, then remove camshaft bearing cap No. 1 and camshaft bearing cap No. 2.

NOTICE:

Loosen each bolt uniformly while keeping the camshaft level.

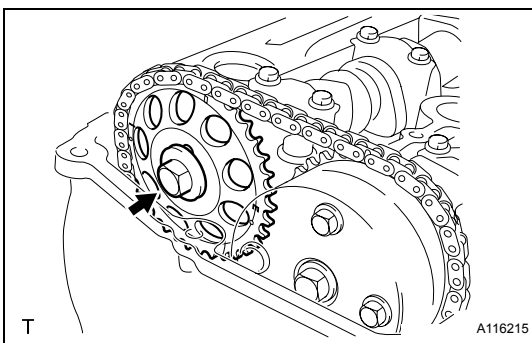

- (k) Remove the fringe bolt and remove the camshaft timing sprocket.

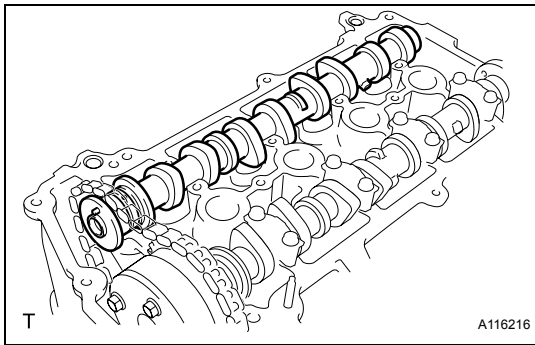

(l) Remove camshaft No. 2.

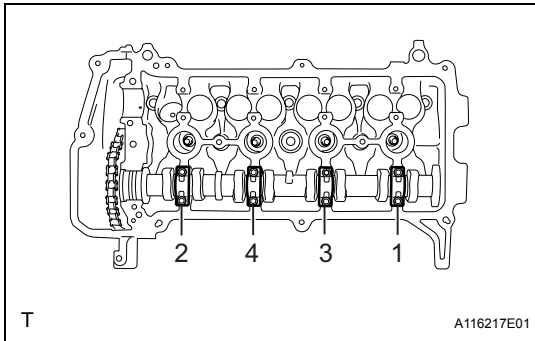

(m) Using several steps, loosen and remove the 8 bearing cap bolts uniformly in the sequence shown in the illustration, then remove camshaft bearing cap No. 2.

NOTICE:

Loosen each bolt uniformly while keeping the camshaft level.

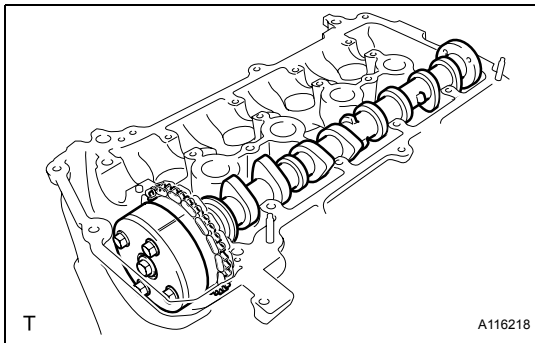

(n) Hold the chain by hand and remove the camshaft and the camshaft timing gear assembly.

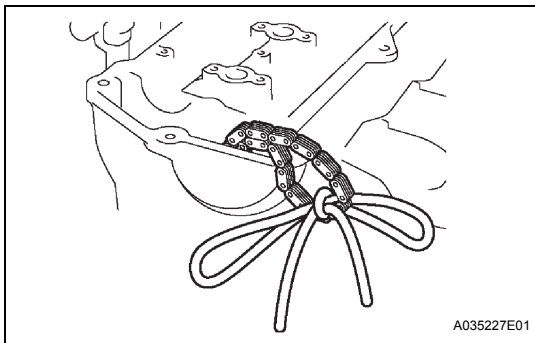

(o) Tie the chain with a piece of string as shown in the illustration.

(p) Remove the 16 valve lifters.

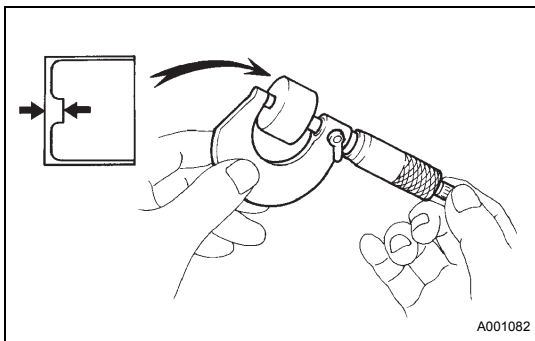

(q) Using a micrometer, measure the thickness of the removed lifter.

(r) Calculate the thickness of a new lifter so that the valve clearance comes to within the specified values.

A	Thickness of new lifter
B	Thickness of used lifter
C	Measured valve clearance

Valve clearance:**Intake $A = B + (C - 0.20 \text{ mm (0.008 in.)})$** **Exhaust $A = B + (C - 0.30 \text{ mm (0.012 in.)})$**

- (s) Select a new lifter with a thickness as close to the calculated values as possible.

HINT:

Lifters are available in 35 sizes in increments of 0.020mm (0.0008 in.), from 5.060 mm (0.1992 in.) to 5.740 mm (0.2260 in.).

Intake valve clearance (cold):
0.15 to 0.25 mm (0.006 to 0.010 in.)

EXAMPLE:

A 5.250 mm (0.2067 in.) lifter is installed, and the measured clearance is 0.400 mm (0.0158 in.). Replace the 5.250 mm (0.2067 in.) lifter with a new No. 46 lifter.

New Shim Thickness

Shim No.	Thickness	Shim No.	Thickness	Shim No.	Thickness
06	5.060 (0.1992)	30	5.300 (0.2087)	54	5.540 (0.2181)
08	5.080 (0.2000)	32	5.320 (0.2094)	56	5.560 (0.2189)
10	5.100 (0.2008)	34	5.340 (0.2102)	58	5.580 (0.2197)
12	5.120 (0.2016)	36	5.360 (0.2110)	60	5.600 (0.2205)
14	5.140 (0.2024)	38	5.380 (0.2118)	62	5.620 (0.2213)
16	5.160 (0.2031)	40	5.400 (0.2126)	64	5.640 (0.2220)
18	5.180 (0.2039)	42	5.420 (0.2134)	66	5.660 (0.2228)
20	5.200 (0.2047)	44	5.440 (0.2142)	68	5.680 (0.2236)
22	5.220 (0.2055)	46	5.460 (0.2150)	70	5.700(0.2244)
24	5.240 (0.2063)	48	5.480 (0.2157)	72	5.720 (0.2252)
26	5.260 (0.2071)	50	5.500 (0.2165)	74	5.740 (0.2260)
28	5.280 (0.2079)	52	5.520 (0.2173)		

Measured clearance mm(in.)	Installed lifter thickness mm(in.)																																																					
	0.000 - 0.030 (0.0000 - 0.0012)	0.031 - 0.050 (0.0012 - 0.0020)	0.051 - 0.070 (0.0020 - 0.0028)	0.071 - 0.090 (0.0028 - 0.0035)	0.091 - 0.110 (0.0036 - 0.0043)	0.111 - 0.130 (0.0044 - 0.0051)	0.131 - 0.150 (0.0052 - 0.0059)	0.151 - 0.170 (0.0059 - 0.0067)	0.171 - 0.190 (0.0067 - 0.0075)	0.191 - 0.210 (0.0075 - 0.0083)	0.211 - 0.230 (0.0083 - 0.0091)	0.231 - 0.249 (0.0091 - 0.0098)	0.250 - 0.350 (0.0098 - 0.0138)	0.351 - 0.370 (0.0138 - 0.0146)	0.371 - 0.390 (0.0146 - 0.0154)	0.391 - 0.410 (0.0154 - 0.0161)	0.411 - 0.430 (0.0162 - 0.0169)	0.431 - 0.450 (0.0170 - 0.0177)	0.451 - 0.470 (0.0178 - 0.0185)	0.471 - 0.490 (0.0185 - 0.0193)	0.491 - 0.510 (0.0193 - 0.0201)	0.511 - 0.530 (0.0201 - 0.0209)	0.531 - 0.550 (0.0209 - 0.0217)	0.551 - 0.570 (0.0217 - 0.0224)	0.571 - 0.590 (0.0225 - 0.0232)	0.591 - 0.610 (0.0233 - 0.0240)	0.611 - 0.630 (0.0241 - 0.0248)	0.631 - 0.650 (0.0248 - 0.0256)	0.651 - 0.670 (0.0256 - 0.0264)	0.671 - 0.690 (0.0264 - 0.0272)	0.691 - 0.710 (0.0272 - 0.0280)	0.711 - 0.730 (0.0280 - 0.0287)	0.731 - 0.750 (0.0288 - 0.0295)	0.751 - 0.770 (0.0296 - 0.0303)	0.771 - 0.790 (0.0304 - 0.0311)	0.791 - 0.810 (0.0311 - 0.0319)	0.811 - 0.830 (0.0319 - 0.0327)	0.831 - 0.850 (0.0327 - 0.0335)	0.851 - 0.870 (0.0335 - 0.0343)	0.871 - 0.890 (0.0343 - 0.0350)	0.891 - 0.910 (0.0351 - 0.0358)	0.911 - 0.930 (0.0359 - 0.0366)	0.931 - 0.950 (0.0367 - 0.0374)	0.951 - 0.970 (0.0374 - 0.0382)	0.971 - 0.990 (0.0382 - 0.0390)	0.991 - 1.010 (0.0390 - 0.0398)	1.011 - 1.030 (0.0398 - 0.0406)							
5.060 (0.1992)														12	14	16	18	20	22	24	26	28	30	32	34	36	38	40	42	44	46	48	50	52	54	56	58	60	62	64	66	68	70	72	74	74	74	74						
5.080 (0.2000)												06		14	16	18	20	22	24	26	28	30	32	34	36	38	40	42	44	46	48	50	52	54	56	58	60	62	64	66	68	70	72	74	74	74	74	74	74					
5.100 (0.2008)											06	06		16	18	20	22	24	26	28	30	32	34	36	38	40	42	44	46	48	50	52	54	56	58	60	62	64	66	68	70	72	74	74	74	74	74	74	74					
5.120 (0.2016)											06	06	06	16	18	20	22	24	26	28	30	32	34	36	38	40	42	44	46	48	50	52	54	56	58	60	62	64	66	68	70	72	74	74	74	74	74	74	74	74				
5.140 (0.2024)											06	06	06	06	08	10	12	14	16	18	20	22	24	26	28	30	32	34	36	38	40	42	44	46	48	50	52	54	56	58	60	62	64	66	68	70	72	74	74	74	74	74		
5.160 (0.2031)											06	06	06	06	08	10	12	14	16	18	20	22	24	26	28	30	32	34	36	38	40	42	44	46	48	50	52	54	56	58	60	62	64	66	68	70	72	74	74	74	74	74		
5.180 (0.2039)											06	06	06	08	10	12	14	16	18	20	22	24	26	28	30	32	34	36	38	40	42	44	46	48	50	52	54	56	58	60	62	64	66	68	70	72	74	74	74	74	74	74		
5.200 (0.2047)											06	06	06	08	10	12	14	16	18	20	22	24	26	28	30	32	34	36	38	40	42	44	46	48	50	52	54	56	58	60	62	64	66	68	70	72	74	74	74	74	74	74		
5.210 (0.2051)											06	06	06	08	10	12	14	16	18	20	22	24	26	28	30	32	34	36	38	40	42	44	46	48	50	52	54	56	58	60	62	64	66	68	70	72	74	74	74	74	74	74		
5.220 (0.2055)											06	06	06	08	10	12	14	16	18	20	22	24	26	28	30	32	34	36	38	40	42	44	46	48	50	52	54	56	58	60	62	64	66	68	70	72	74	74	74	74	74	74	74	
5.230 (0.2059)											06	06	06	08	10	12	14	16	18	20	22	24	26	28	30	32	34	36	38	40	42	44	46	48	50	52	54	56	58	60	62	64	66	68	70	72	74	74	74	74	74	74	74	
5.240 (0.2063)											06	06	06	08	10	12	14	16	18	20	22	24	26	28	30	32	34	36	38	40	42	44	46	48	50	52	54	56	58	60	62	64	66	68	70	72	74	74	74	74	74	74	74	
5.250 (0.2067)											06	06	06	10	12	14	16	18	20	22	24	26	28	30	32	34	36	38	40	42	44	46	48	50	52	54	56	58	60	62	64	66	68	70	72	74	74	74	74	74	74	74	74	
5.260 (0.2071)											06	06	06	08	10	12	14	16	18	20	22	24	26	28	30	32	34	36	38	40	42	44	46	48	50	52	54	56	58	60	62	64	66	68	70	72	74	74	74	74	74	74	74	
5.270 (0.2075)											06	06	06	08	10	12	14	16	18	20	22	24	26	28	30	32	34	36	38	40	42	44	46	48	50	52	54	56	58	60	62	64	66	68	70	72	74	74	74	74	74	74	74	
5.280 (0.2079)											06	06	06	08	10	12	14	16	18	20	22	24	26	28	30	32	34	36	38	40	42	44	46	48	50	52	54	56	58	60	62	64	66	68	70	72	74	74	74	74	74	74	74	
5.290 (0.2083)											06	06	08	10	12	14	16	18	20	22	24	26	28	30	32	34	36	38	40	42	44	46	48	50	52	54	56	58	60	62	64	66	68	70	72	74	74	74	74	74	74	74	74	
5.300 (0.2087)											06	06	08	10	12	14	16	18	20	22	24	26	28	30	32	34	36	38	40	42	44	46	48	50	52	54	56	58	60	62	64	66	68	70	72	74	74	74	74	74	74	74	74	
5.310 (0.2091)											06	06	08	10	12	14	16	18	20	22	24	26	28	30	32	34	36	38	40	42	44	46	48	50	52	54	56	58	60	62	64	66	68	70	72	74	74	74	74	74	74	74	74	
5.320 (0.2094)											06	06	08	10	12	14	16	18	20	22	24	26	28	30	32	34	36	38	40	42	44	46	48	50	52	54	56	58	60	62	64	66	68	70	72	74	74	74	74	74	74	74	74	
5.330 (0.2098)											06	08	10	12	14	16	18	20	22	24	26	28	30	32	34	36	38	40	42	44	46	48	50	52	54	56	58	60	62	64	66	68	70	72	74	74	74	74	74	74	74	74	74	
5.340 (0.2102)											06	08	10	12	14	16	18	20	22	24	26	28	30	32	34	36	38	40	42	44	46	48	50	52	54	56	58	60	62	64	66	68	70	72	74	74	74	74	74	74	74	74	74	
5.350 (0.2106)											08	10	12	14	16	18	20	22	24	26	28	30	32	34	36	38	40	42	44	46	48	50	52	54	56	58	60	62	64	66	68	70	72	74	74	74	74	74	74	74	74	74	74	74
5.360 (0.2110)											08	10	12	14	16	18	20	22	24	26	28	30	32	34	36	38	40	42	44	46	48	50	52	54	56	58	60	62	64	66	68	70	72	74	74	74	74	74	74	74	74	74	74	74
5.370 (0.2114)											10	12	14	16	18	20	22	24	26	28	30	32	34	36	38	40	42	44	46	48	50	52	54	56	58	60	62	64	66	68	70	72	74	74	74	74	74	74	74	74	74	74	74	74
5.380 (0.2118)											10	12	14	16	18	20	22	24	26	28	30	32	34	36	38	40	42	44	46	48	50	52	54	56	58	60	62	64	66	68	70	72	74	74	74	74	74	74	74	74	74	74	74	74
5.390 (0.2122)											12	14	16	18	20	22	24	26	28	30	32	34	36	38	40	42	44	46	48	50	52	54	56	58	60	62	64	66	68	70	72	74	74	74	74	74	74	74	74	74	74	74	74	74
5.400 (0.2126)											12	14	16	18	20	22	24	26	28	30	32	34	36	38	40	42	44	46	48	50	52	54	56	58	60	62	64	66	68	70	72	74	74	74	74	74	74	74	74	74	74	74	74	74
5.410 (0.2130)											14	16	18	20	22	24	26	28	30	32	34	36	38	40	42	44	46	48	50	52	54	56	58	60	62	64	66	68	70	72	74	74	74	74	74	74	74	74	74	74	74	74	74	74
5.420 (0.2134)											14	16	18	20	22	24	26	28	30	32	34	36	38	40	42	44	46	48	50	52	54	56	58	60	62																			

Exhaust valve clearance (Cold):
0.25 to 0.35 mm (0.010 to 0.014 in.)

EXAMPLE:

A 5.340 mm (0.2102 in.) lifter is installed, and the measured clearance is 0.440 mm (0.0173 in.). Replace the 5.340 mm (0.2102 in.) lifter with a new No. 48 lifter.

New Shim Thickness

Shim No.	Thickness	Shim No.	Thickness	Shim No.	Thickness
06	5.060 (0.1992)	30	5.300 (0.2087)	54	5.540 (0.2181)
08	5.080 (0.2000)	32	5.320 (0.2094)	56	5.560 (0.2189)
10	5.100 (0.2008)	34	5.340 (0.2102)	58	5.580 (0.2197)
12	5.120 (0.2016)	36	5.360 (0.2110)	60	5.600 (0.2205)
14	5.140 (0.2024)	38	5.380 (0.2118)	62	5.620 (0.2213)
16	5.160 (0.2031)	40	5.400 (0.2126)	64	5.640 (0.2220)
18	5.180 (0.2039)	42	5.420 (0.2134)	66	5.660 (0.2228)
20	5.200 (0.2047)	44	5.440 (0.2142)	68	5.680 (0.2236)
22	5.220 (0.2055)	46	5.460 (0.2150)	70	5.700 (0.2244)
24	5.240 (0.2063)	48	5.480 (0.2157)	72	5.720 (0.2252)
26	5.260 (0.2071)	50	5.500 (0.2165)	74	5.740 (0.2260)
28	5.280 (0.2079)	52	5.520 (0.2173)		

- (t) Install the selected valve lifter.
- (u) Apply a light coat of engine oil to the camshaft and camshaft journals.
- (v) Install the chain onto the camshaft timing gear with the paint mark and the timing mark aligned as shown in the illustration.

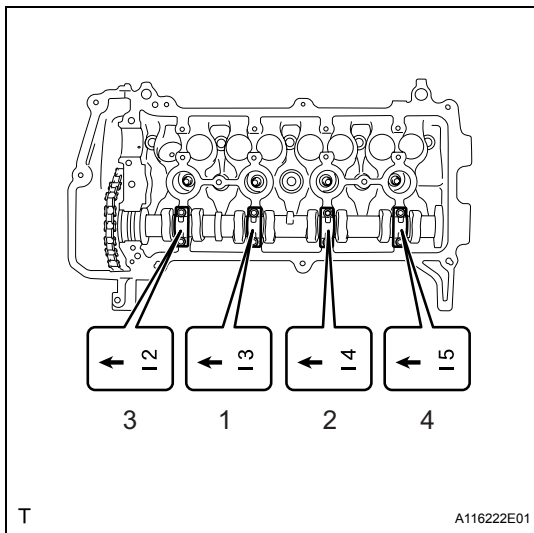
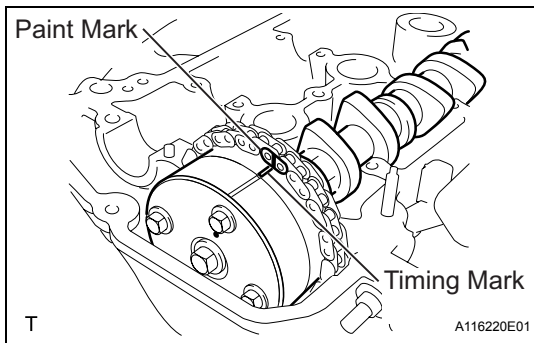

- (w) Examine the front marks and the numbers on camshaft bearing cap No. 2 and check that the sequence is as shown in the illustration. Then uniformly tighten the bolts in several steps in the sequence shown in the illustration.
Torque: 13 N*m (129 kgf*cm, 9.4 ft.*lbf)
NOTICE:
Tighten each bolt uniformly while keeping the camshaft level.

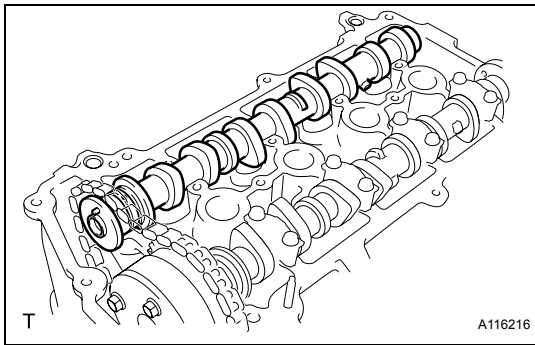

(x) Install camshaft No. 2.

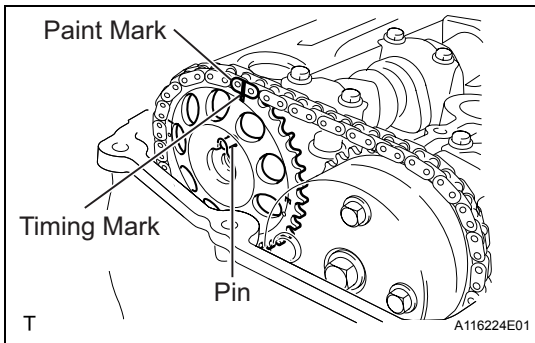

- (y) Hold the chain, and align the timing mark on the camshaft timing sprocket with the paint mark of the chain.
- (z) Align the alignment pin hole in the camshaft timing sprocket with the alignment pin of the camshaft, and install the sprocket onto the camshaft.

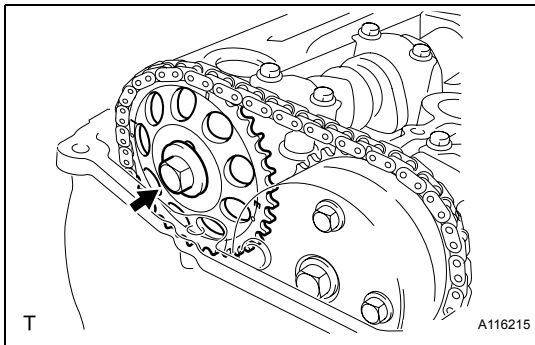

(aa) Provisionally install the flange bolt.

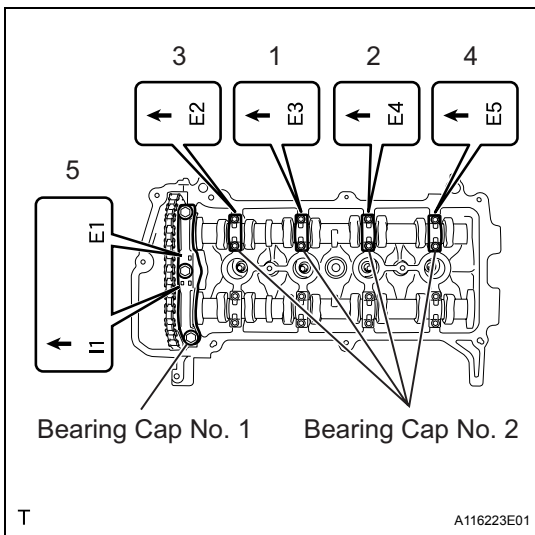

(ab) Examine the front marks and the numbers of camshaft bearing cap No. 1 and camshaft bearing cap No. 2 and check that the sequence is as shown in the illustration. Then uniformly tighten the bolts in several steps, in the sequence shown in the illustration.

Torque: for bearing cap No. 2
 13 N*m (129 kgf*cm, 9.4 ft.*lbf)
for bearing cap No. 1
 23 N*m (235 kgf*cm, 17 ft.*lbf)

NOTICE:
 Tighten each bolt uniformly while keeping the camshaft level.

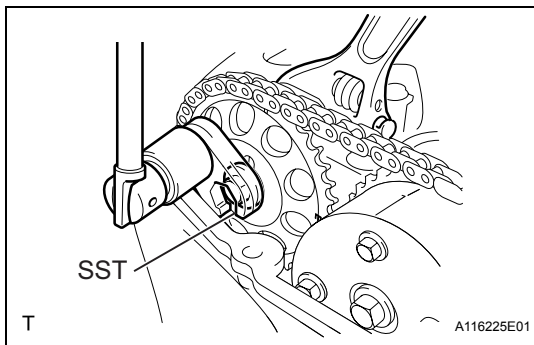

(ac) Using a wrench, hold the hexagonal lobe of camshaft No. 2 and install the flange bolt.

Torque: 64 N*m (653 kgf*cm, 47 ft.*lbf)
SST 09023-38400

(ad) Remove the bar from the timing chain tensioner.

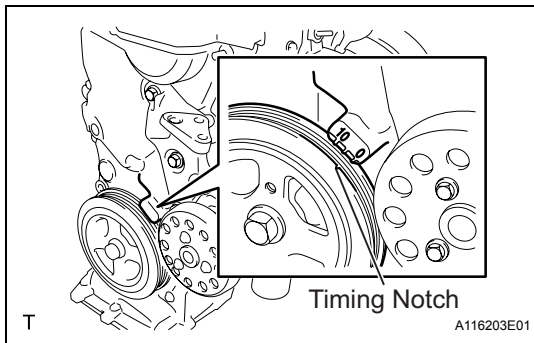

(ae) Turn the crankshaft damper and align its timing notch with the timing mark "0" of the oil pump.

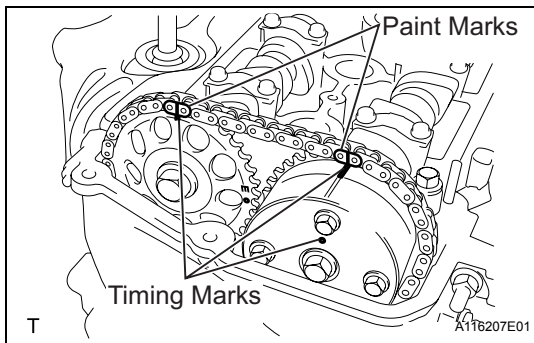

(af) Check that all the pairs of timing marks are aligned.

(ag) Apply adhesive to the 2 or 3 threads of the screw plug.

Adhesive:

Toyota Genuine Adhesive 1324, Three Bond 1324 or Equivalent

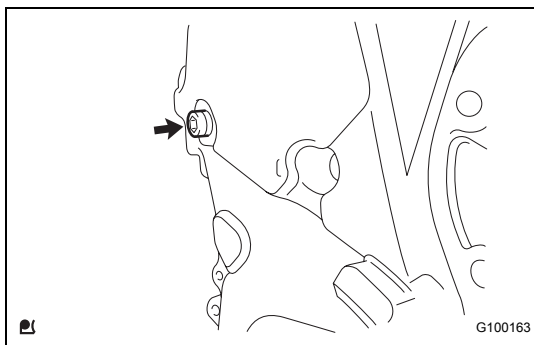

(ah) Using an 8 mm hexagon wrench, install the screw plug.

Torque: 15 N*m (153 kgf*cm, 11 ft.*lbf)

(ai) Install the engine mounting insulator sub-assembly RH (See page [LU-26](#)). (for Hatchback)

(aj) Install the engine mounting insulator sub-assembly RH (See page [LU-26](#)). (for Sedan)

(ak) Install the fan and generator V belt (See page [EM-7](#)).

(al) Adjust the fan and generator V belt (See page [EM-7](#)).

(am) Inspect the fan and generator V belt (See page [EM-8](#)).

10. INSTALL CYLINDER HEAD COVER SUB-ASSEMBLY
 (See page [FU-19](#))

11. CONNECT VENTILATION HOSE NO. 2 (See page [FU-20](#))

12. CONNECT VENTILATION HOSE (See page [FU-20](#))

13. INSTALL IGNITION COIL NO. 1 (See page [IG-9](#))

14. **CONNECT CABLE TO NEGATIVE BATTERY
TERMINAL**
Torque: 5.4 N*m (55 kgf*cm, 48 in.*lbf)
15. **CHECK FOR ENGINE OIL LEAKAGE**
16. **INSTALL CYLINDER HEAD COVER NO. 2 (See page
[IG-10](#))**
17. **INSTALL ENGINE UNDER COVER RH**

TIMING CHAIN

COMPONENTS

EM

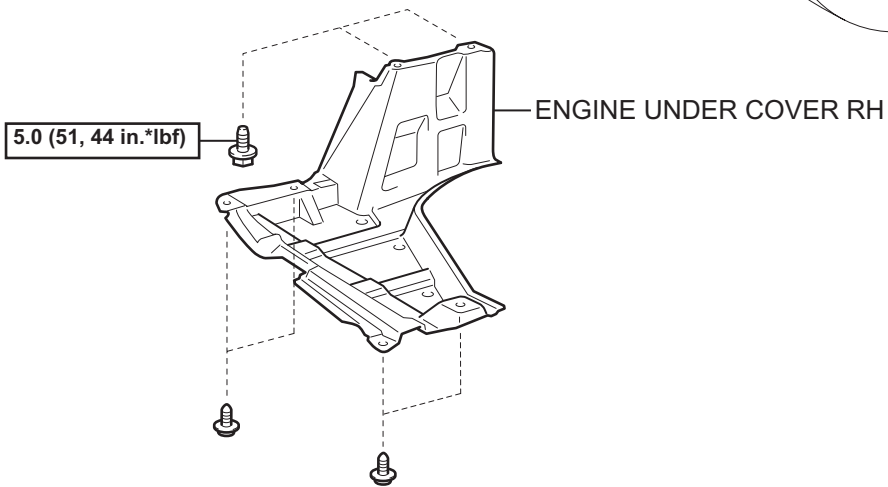
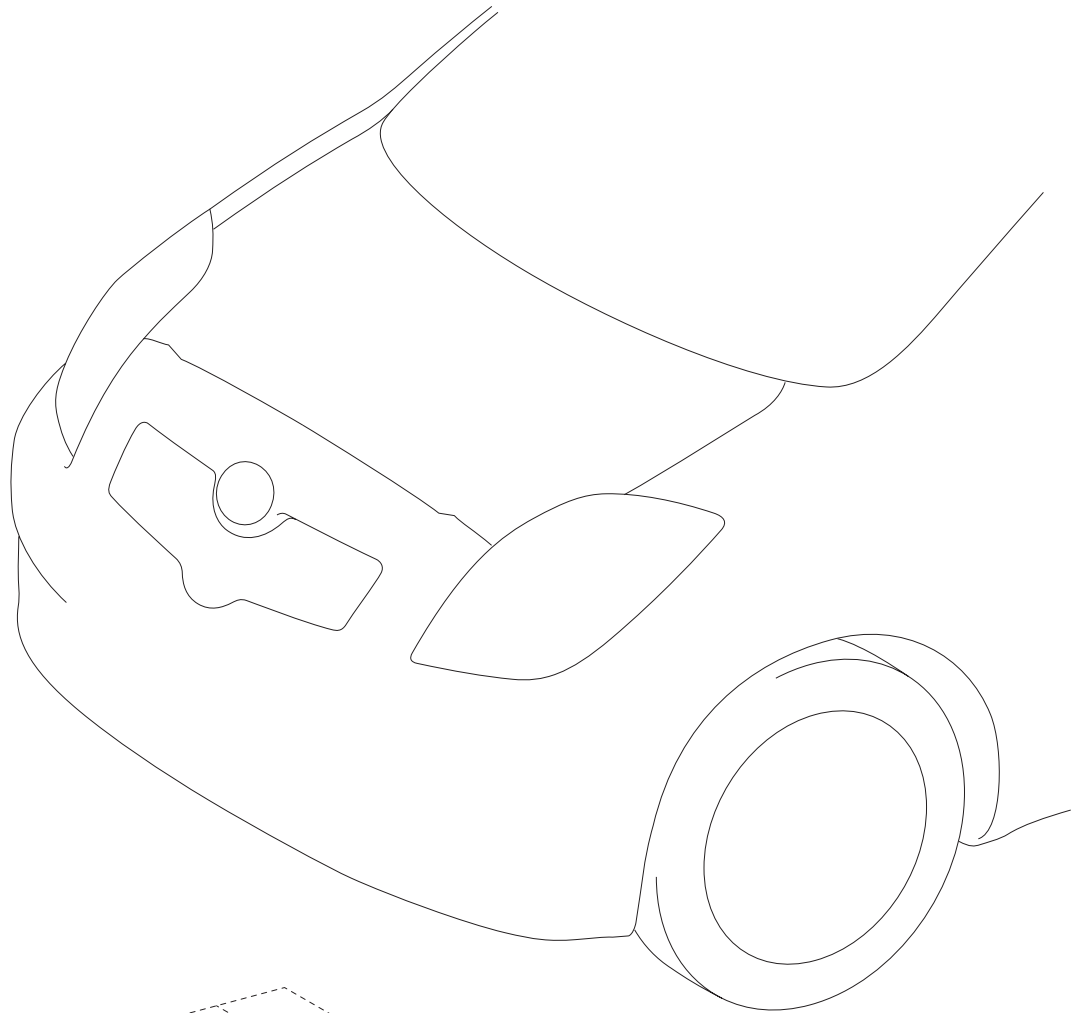

N*m (kgf*cm, ft.*lbf) : Specified torque

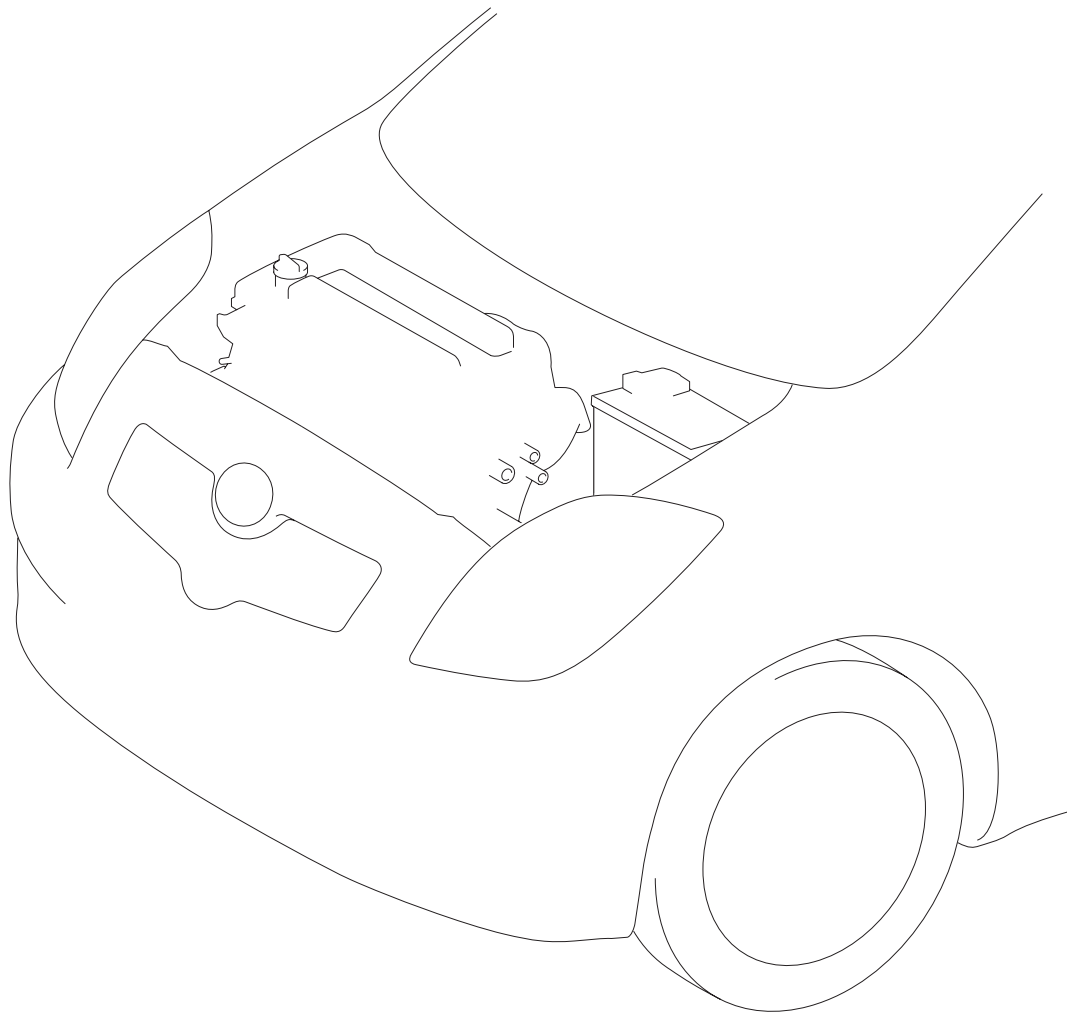
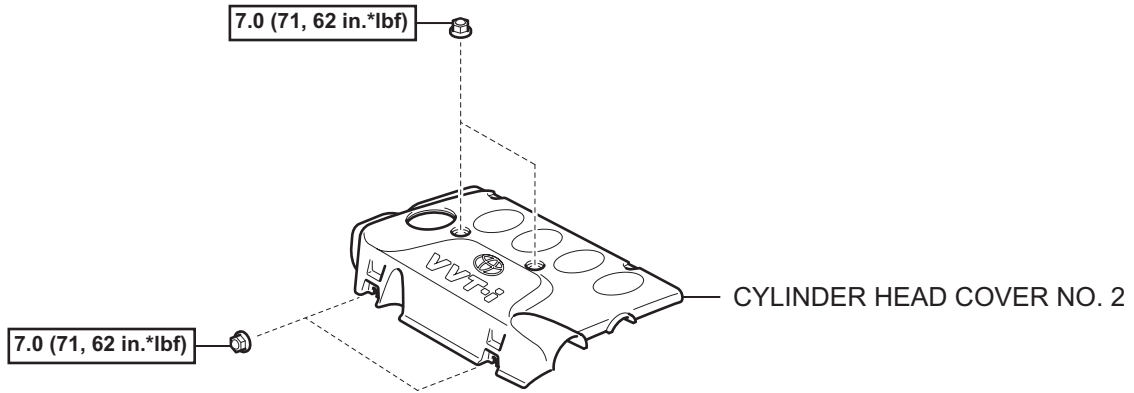

N*m (kgf*cm, ft.*lbf) : Specified torque

EM

EM

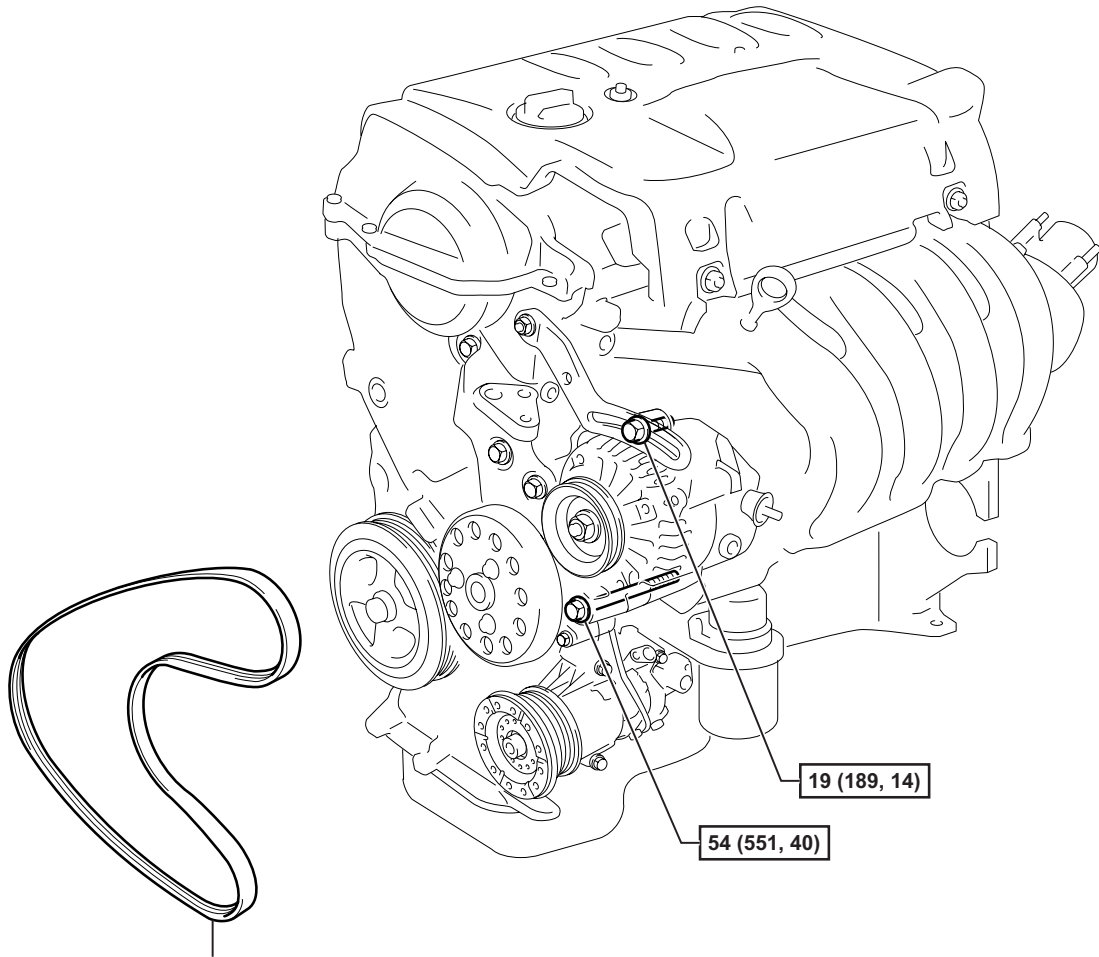

FAN AND GENERATOR V BELT

N*m (kgf*cm, ft.*lbf) : Specified torque

T

for Hatchback:

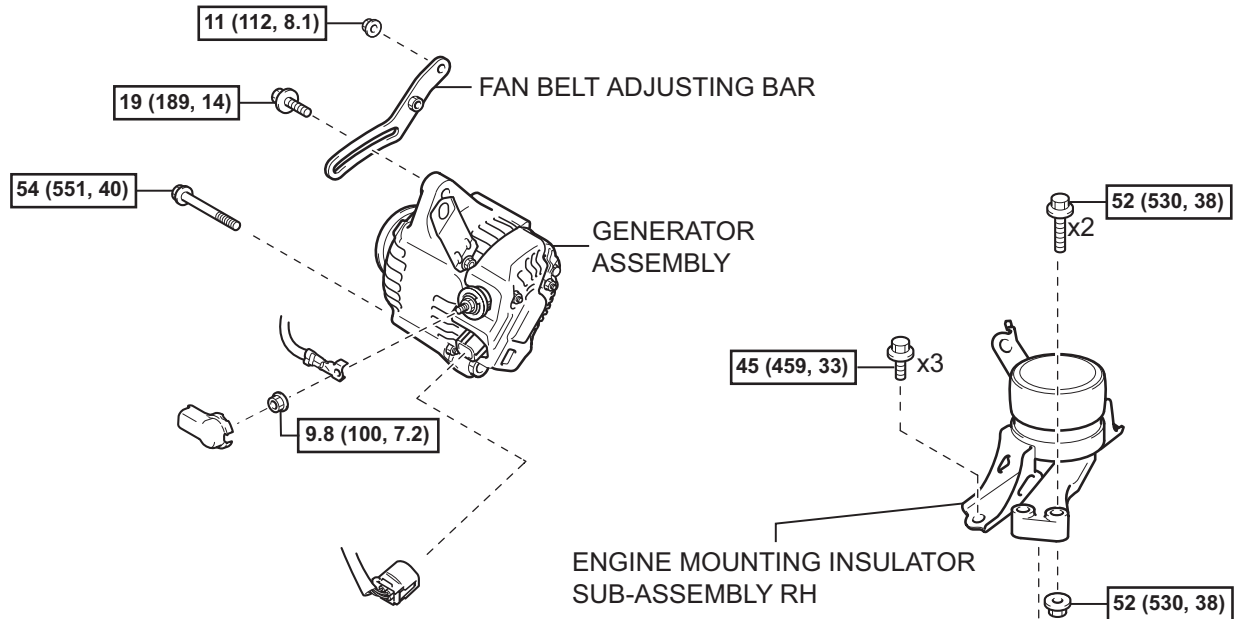

EM

N*m (kgf*cm, ft.*lbf) : Specified torque

T

for Sedan:

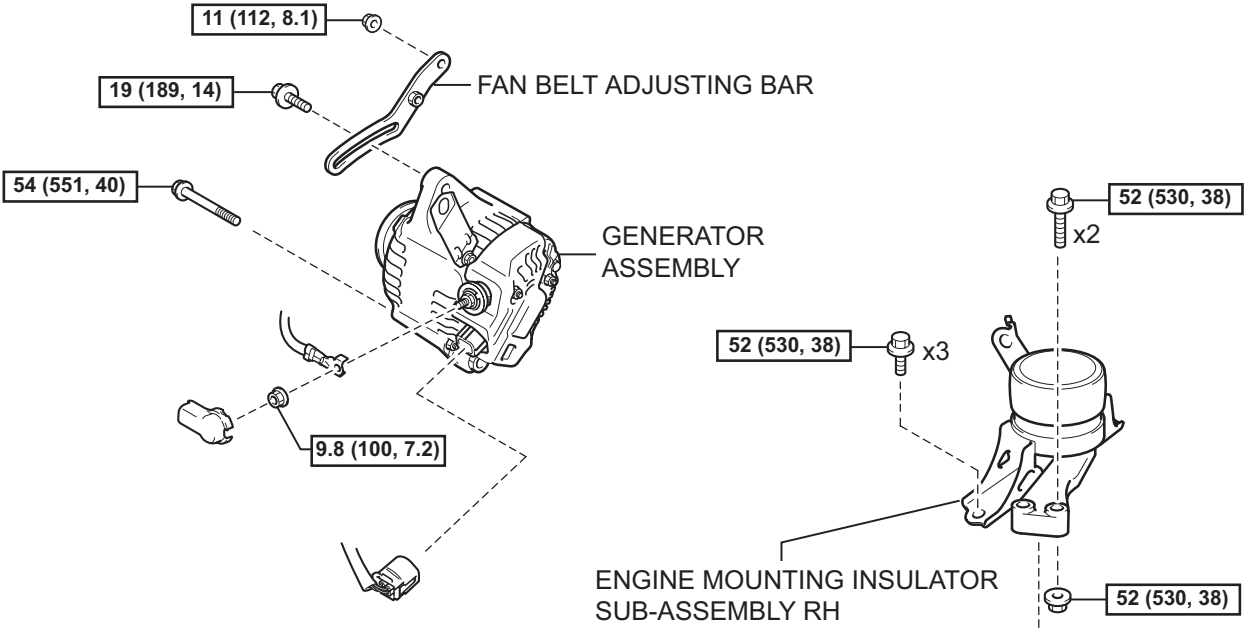

EM

N*m (kgf*cm, ft*lbf) : Specified torque

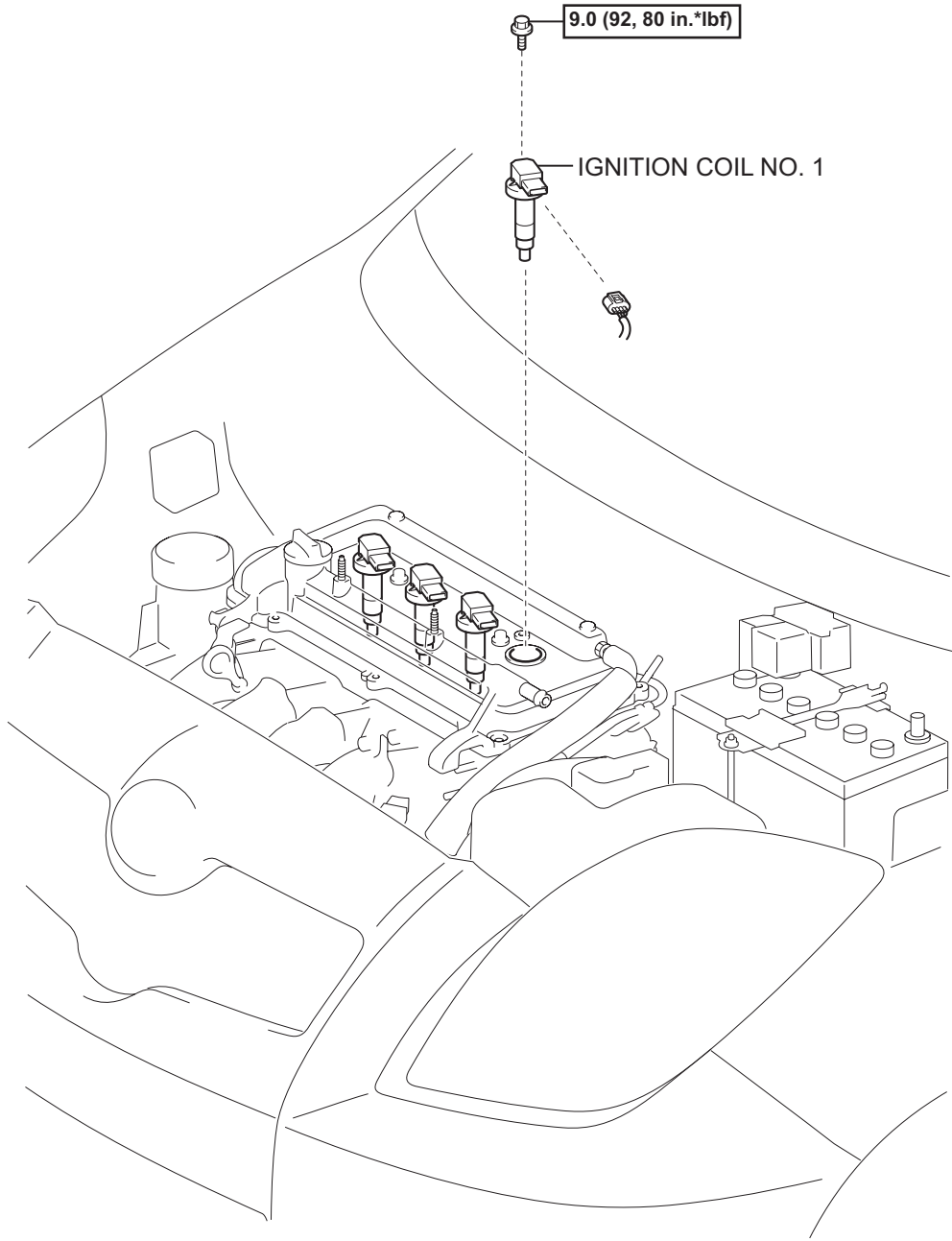

N*m (kgf*cm, ft.*lbf) : Specified torque

EM

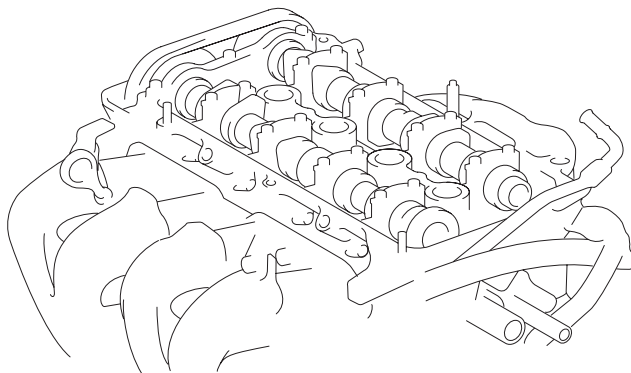
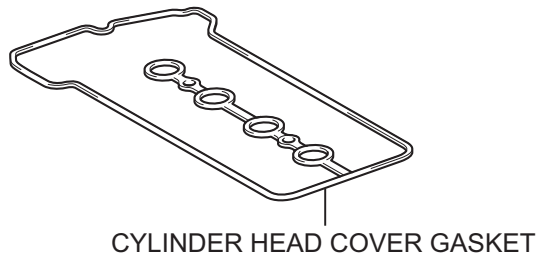
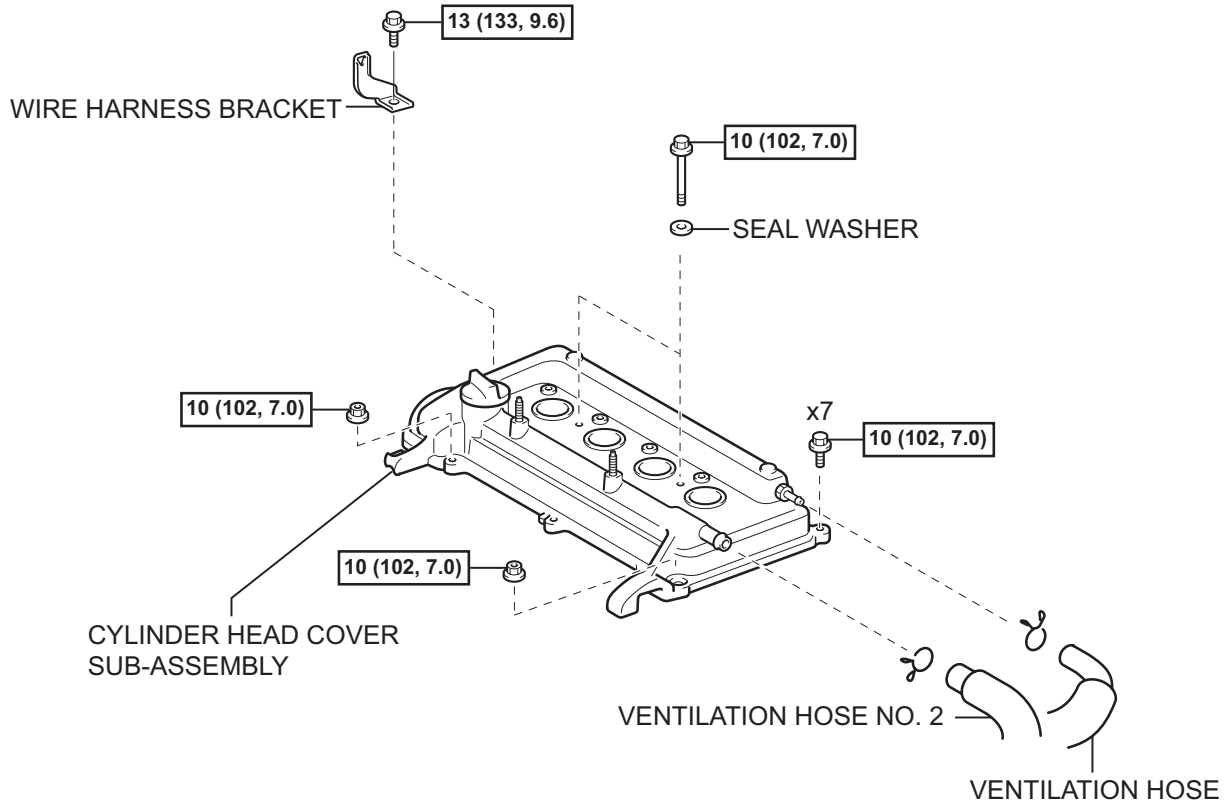

N*m (kgf*cm, ft.*lbf) : Specified torque

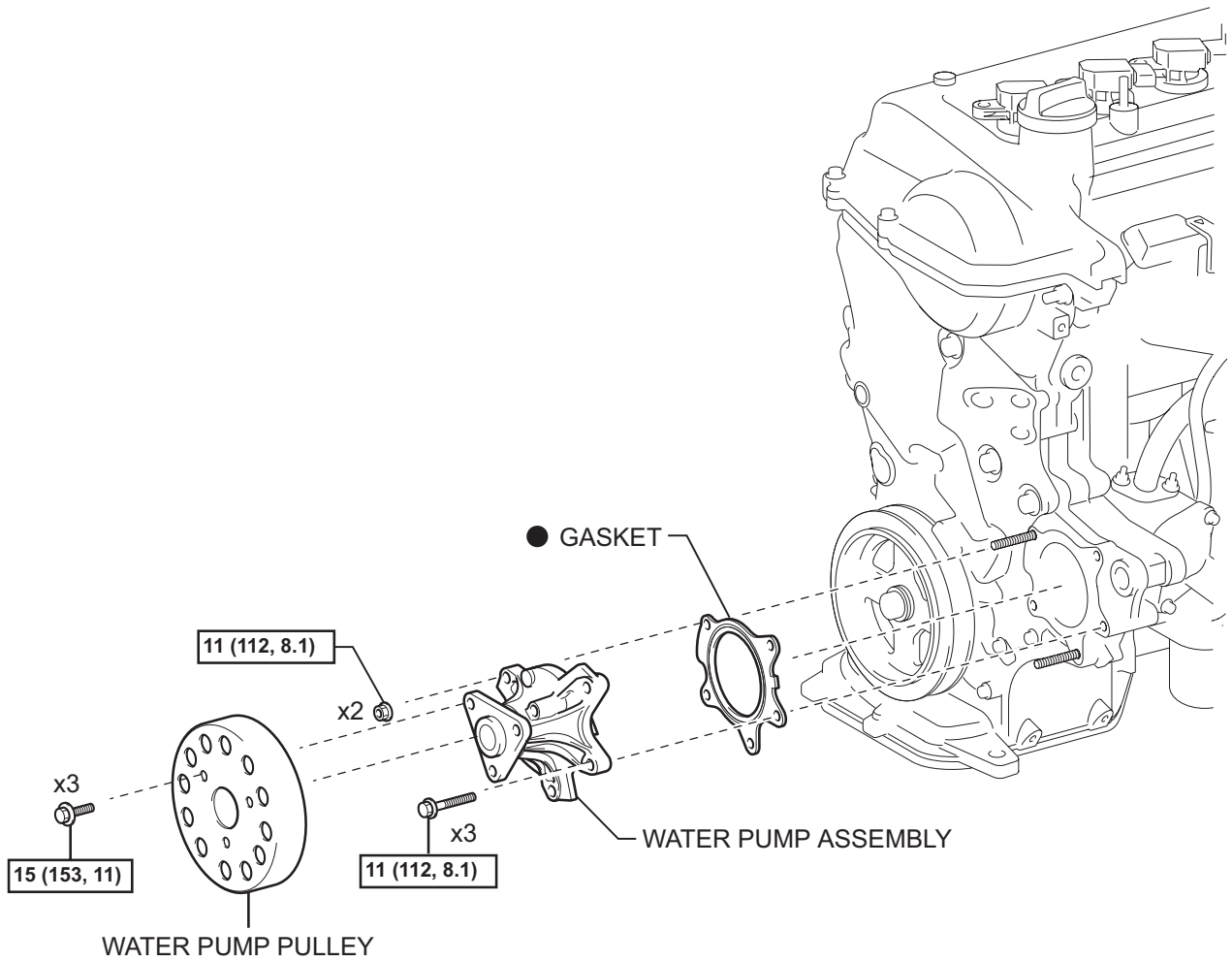

[N*m (kgf*cm, ft.*lbf)] : Specified torque

● Non-reusable part

T

EM

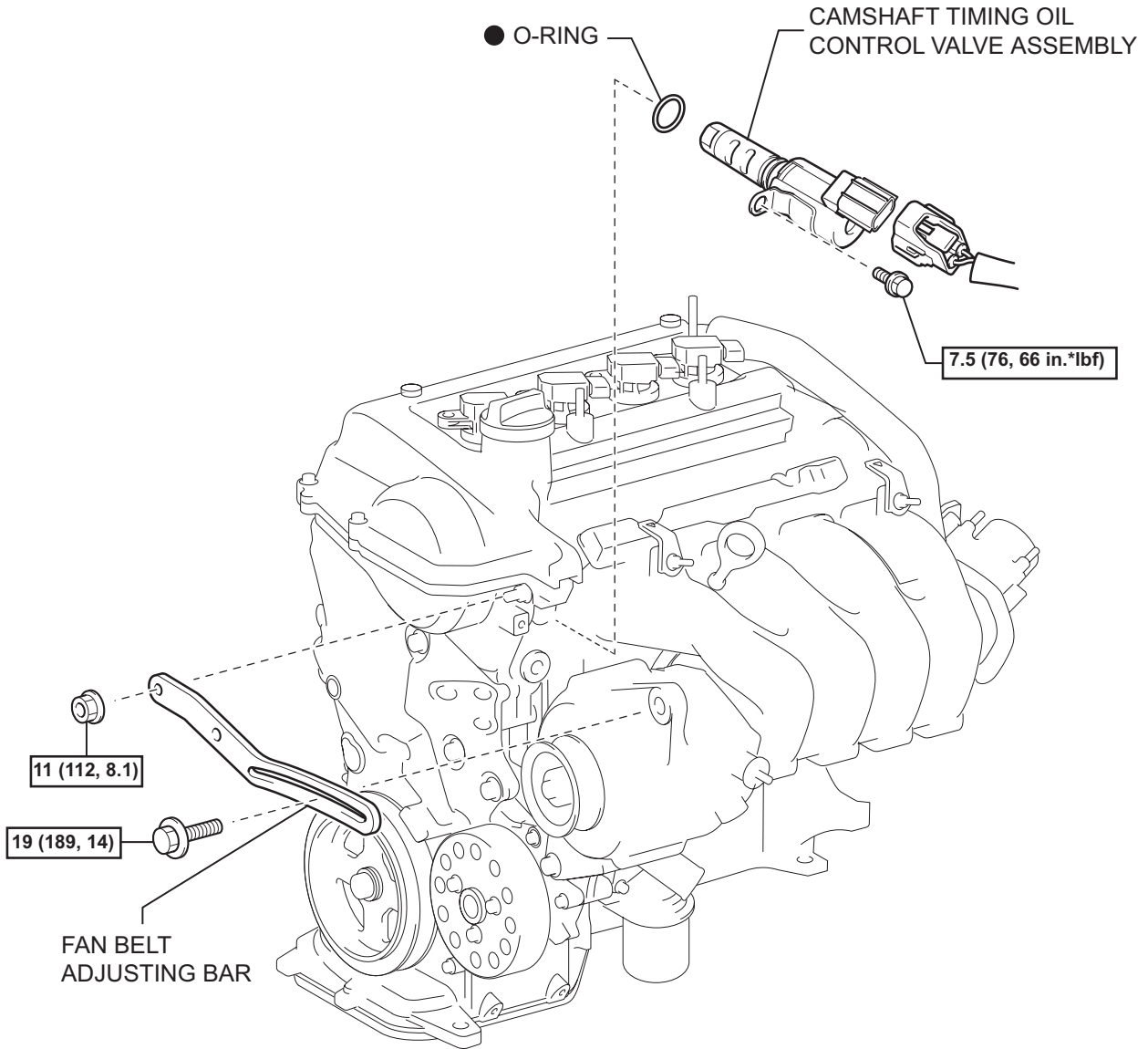

[N*m (kgf*cm, ft.*lbf)] : Specified torque

● Non-reusable part

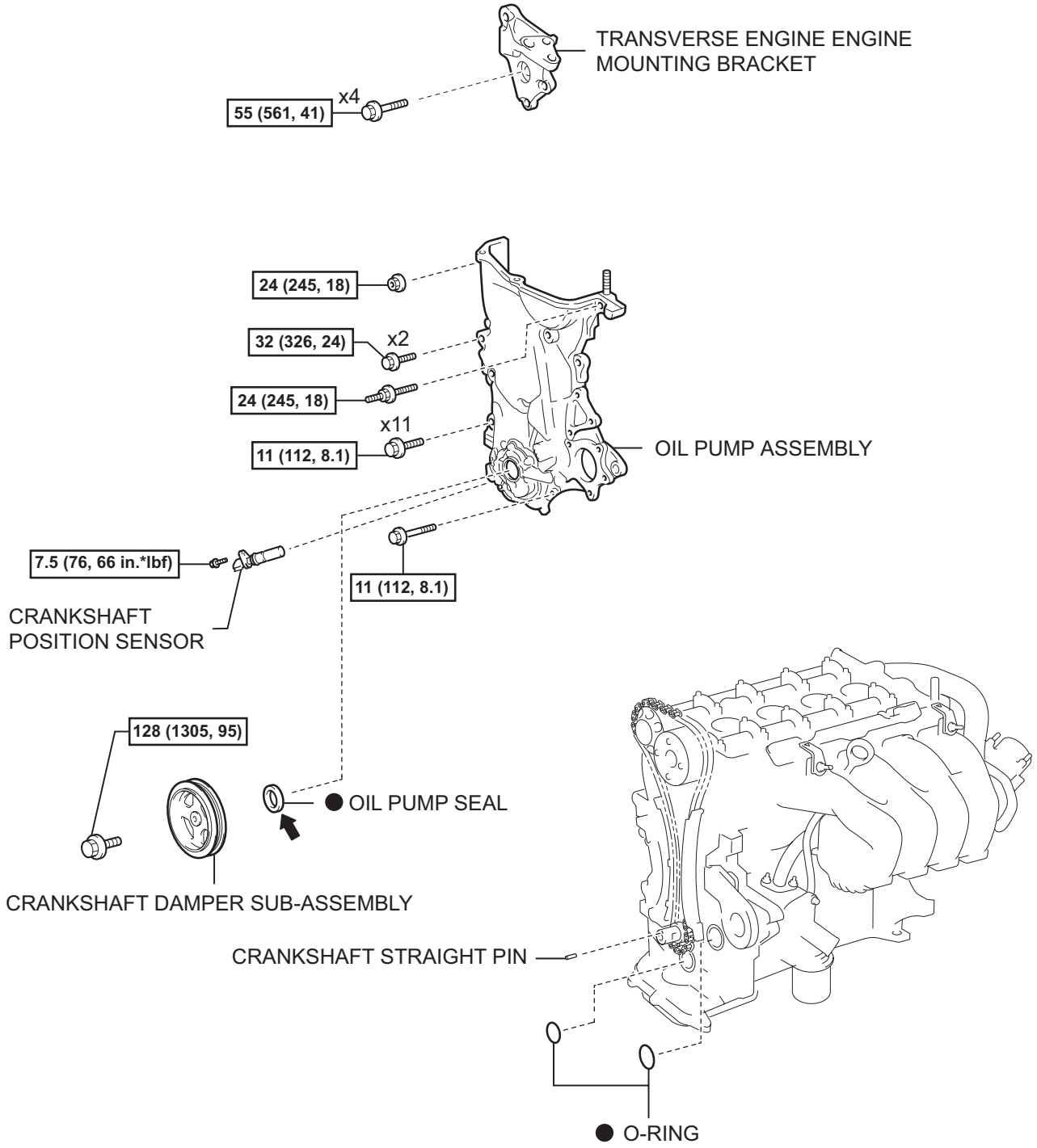

N*m (kgf*cm, ft.*lbf) : Specified torque

● Non-reusable part ← Apply MP grease

EM

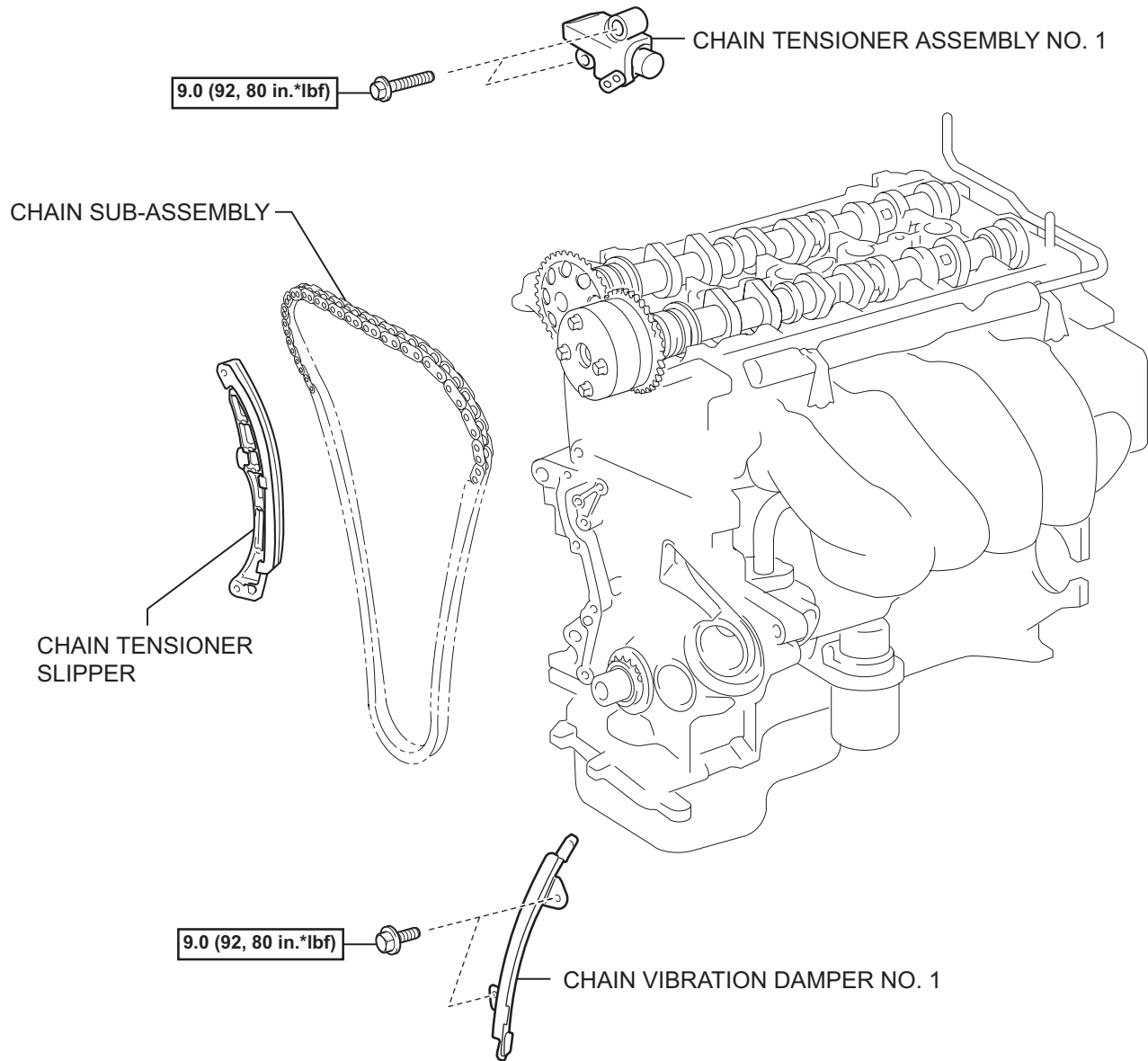

N*m (kgf*cm, ft.*lbf) : Specified torque

REMOVAL

1. DISCONNECT CABLE FROM NEGATIVE BATTERY TERMINAL
2. REMOVE FRONT WHEEL RH
3. REMOVE ENGINE UNDER COVER RH
4. DRAIN ENGINE OIL
5. DRAIN ENGINE COOLANT (See page [CO-8](#))
6. REMOVE CYLINDER HEAD COVER NO. 2 (See page [IG-9](#))
7. REMOVE FAN AND GENERATOR V BELT (See page [EM-7](#))
8. REMOVE GENERATOR ASSEMBLY (See page [CH-10](#))
9. REMOVE IGNITION COIL NO. 1 (See page [IG-9](#))
10. DISCONNECT VENTILATION HOSE (See page [FU-13](#))
11. DISCONNECT VENTILATION HOSE NO. 2 (See page [FU-13](#))
12. REMOVE CYLINDER HEAD COVER SUB-ASSEMBLY (See page [FU-13](#))
13. REMOVE ENGINE MOUNTING INSULATOR SUB-ASSEMBLY RH (See page [LU-17](#))
14. REMOVE CRANKSHAFT DAMPER SUB-ASSEMBLY (See page [LU-18](#))
15. REMOVE CRANKSHAFT POSITION SENSOR (See page [ES-403](#))
16. REMOVE CAMSHAFT TIMING OIL CONTROL VALVE ASSEMBLY (See page [ES-396](#))
17. REMOVE WATER PUMP PULLEY (See page [CO-15](#))
18. REMOVE WATER PUMP ASSEMBLY (See page [CO-15](#))
19. REMOVE TRANSVERSE ENGINE ENGINE MOUNTING BRACKET (See page [LU-18](#))
20. REMOVE OIL PUMP ASSEMBLY (See page [LU-19](#))
21. REMOVE OIL PUMP SEAL (See page [LU-21](#))
22. REMOVE CHAIN TENSIONER ASSEMBLY NO. 1
NOTICE:
 - Do not rotate the crankshaft with the chain tensioner removed.
 - When rotating the camshaft with the timing chain removed, rotate the crankshaft counterclockwise 40° from the TDC first.

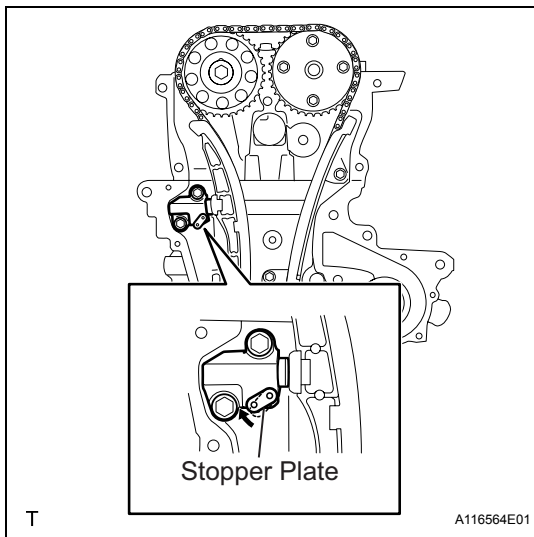

- (a) Pull up the stopper plate and hold it with its lock released.

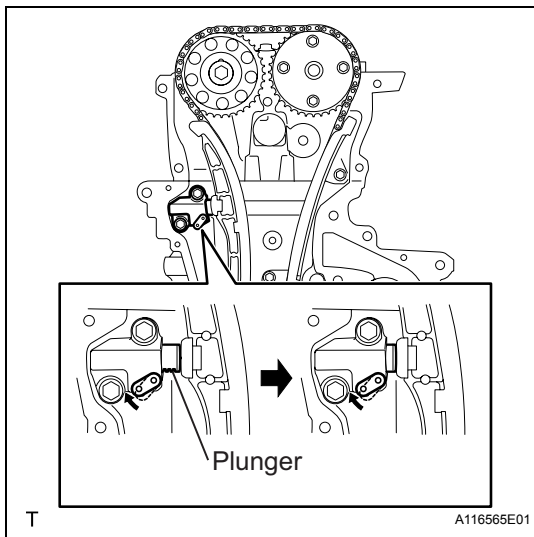

- (b) Unlock the plunger of the tensioner and push it in to the end.

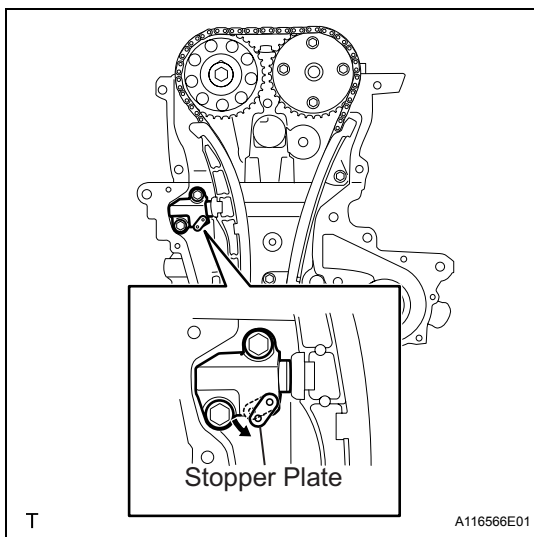

- (c) Pull down the stopper plate with the plunger pushed to the end and lock the plunger.

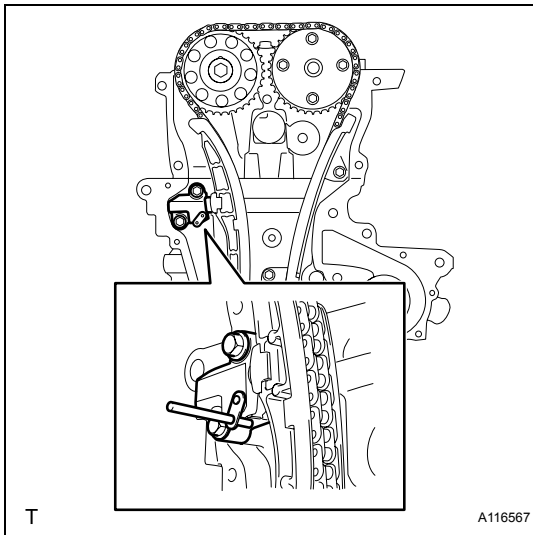

- (d) Insert a 3 mm (0.12 in.) diameter bar into the hole in the stopper plate and lock the plunger.

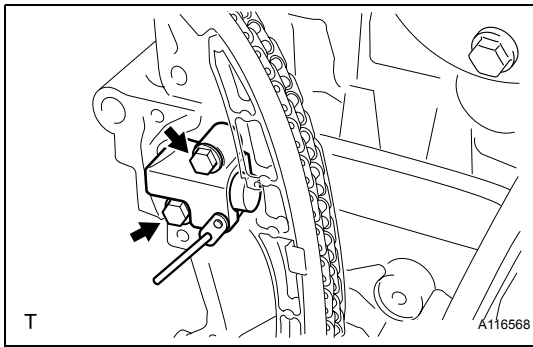

- (e) Remove the 2 bolts and remove chain tensioner assembly No. 1.

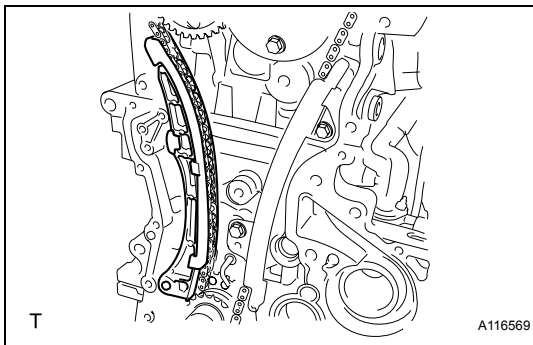

23. REMOVE CHAIN TENSIONER SLIPPER

- (a) Remove the chain tensioner slipper.

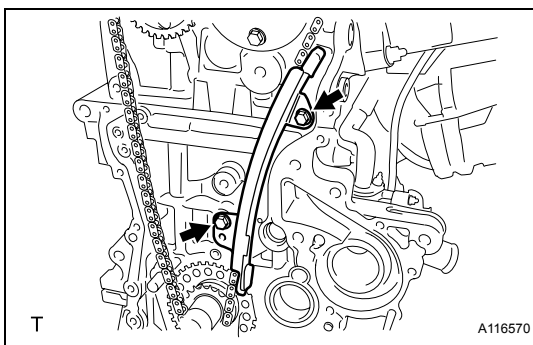

24. REMOVE CHAIN VIBRATION DAMPER NO. 1

- (a) Remove the 2 bolts and remove chain vibration damper No. 1.

25. REMOVE CHAIN SUB-ASSEMBLY

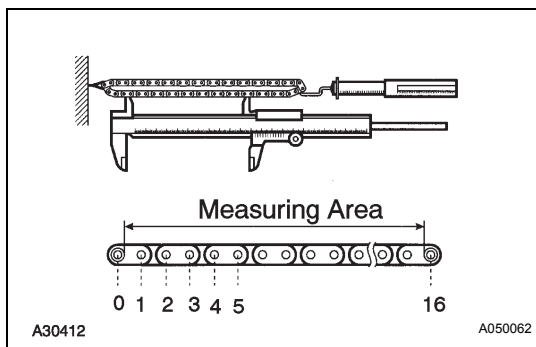

INSPECTION

1. INSPECT CHAIN SUB-ASSEMBLY

- (a) Using a spring scale, apply 140 N (14.3 kgf, 31.5 lb) to the timing chain and measure its length.

Maximum chain elongation:

123.2 mm (4.850 in.)

If the elongation is greater than the maximum, replace the chain.

HINT:

Perform the same measurement at 3 or more random places and calculate the average length.

INSTALLATION

1. INSTALL CHAIN SUB-ASSEMBLY

- (a) Make sure that all the timing marks are in the positions (TDC) shown in the illustration.

HINT:

The positions of the timing marks may differ from the predetermined positions due to the force of the valve spring.

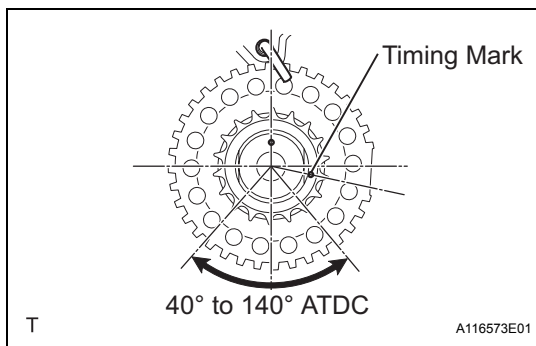
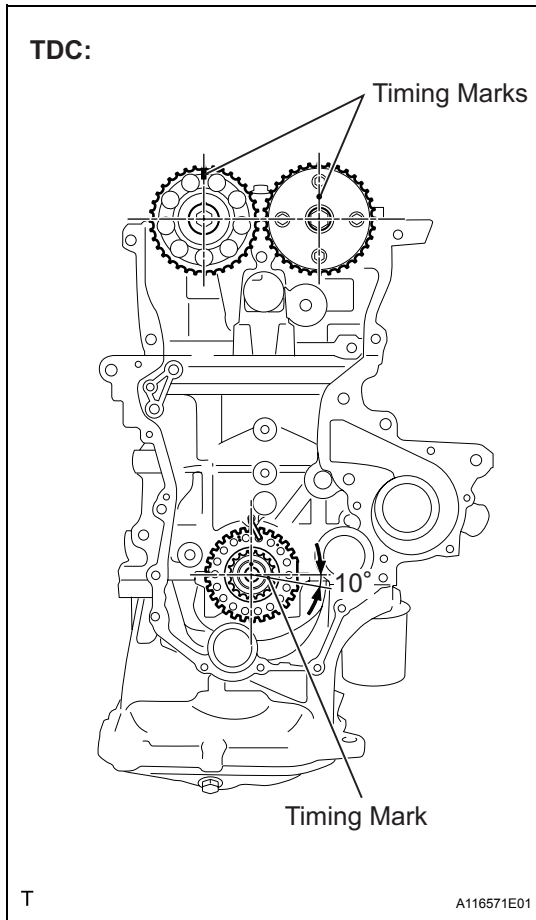

- (b) Set the timing mark of the crankshaft in a position between 40° and 140° ATDC as illustrated.

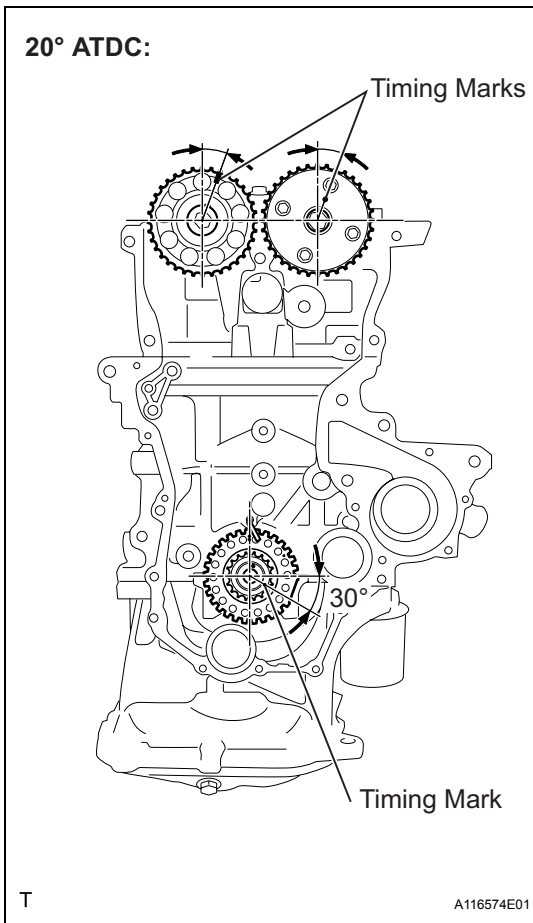

- (c) Set the camshaft timing gear and the camshaft timing sprocket in the positions (20°ATDC) shown in the illustration.
- (d) Set the crankshaft in the position (20°ATDC) shown in the illustration.

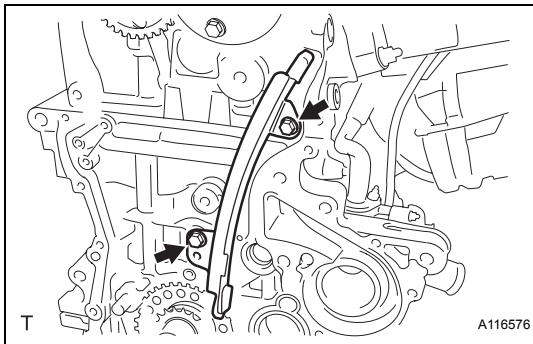

- (e) Install chain vibration damper No. 1 with the 2 bolts.
Torque: 9.0 N*m (92 kgf*cm, 80 in.*lbf)

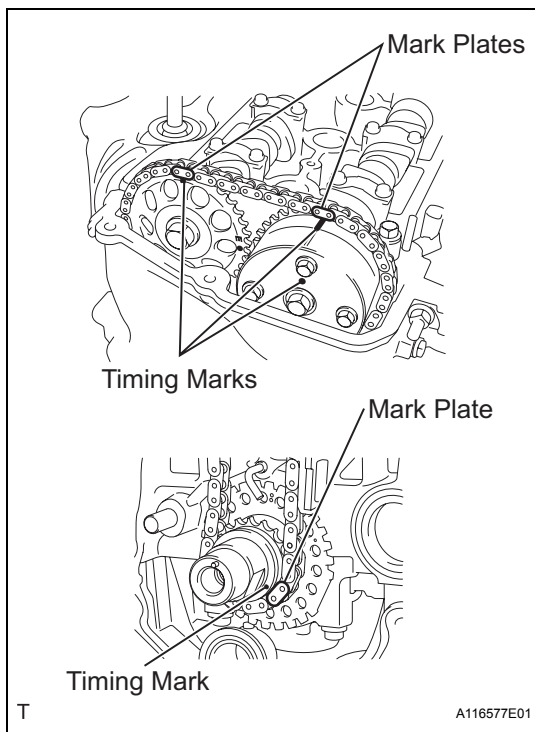

- (f) Align the timing marks of the camshaft with the mark plates of the timing chain and install the timing chain.

HINT:

Align the timing marks with the mark plates while turning the hexagonal service portion of the camshaft using a wrench.

EM

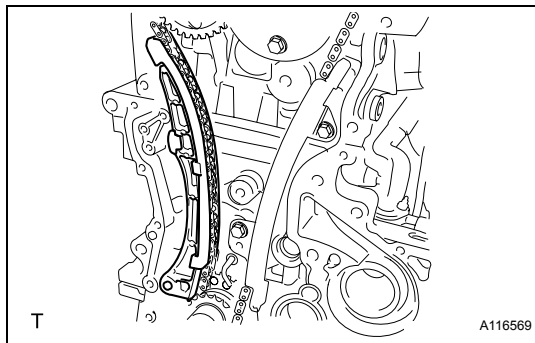

2. INSTALL CHAIN TENSIONER SLIPPER

- (a) Install the chain tensioner slipper.

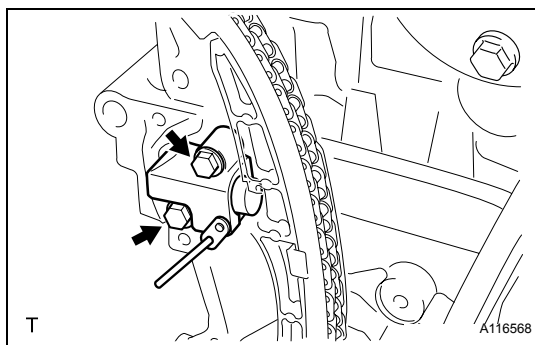

3. INSTALL CHAIN TENSIONER ASSEMBLY NO. 1

- (a) Install chain tensioner assembly No. 1 with the 2 bolts.

Torque: 9.0 N*m (92 kgf*cm, 80 in.*lbf)

- (b) Remove the bar from chain tensioner assembly No. 1.

4. INSTALL OIL PUMP SEAL (See page [LU-21](#))

5. INSTALL OIL PUMP ASSEMBLY (See page [LU-22](#))

6. INSTALL TRANSVERSE ENGINE ENGINE MOUNTING BRACKET (See page [LU-26](#))

7. INSTALL WATER PUMP ASSEMBLY (See page [CO-16](#))

8. INSTALL WATER PUMP PULLEY (See page [CO-16](#))

9. INSTALL CAMSHAFT TIMING OIL CONTROL VALVE ASSEMBLY (See page [ES-397](#))

10. INSTALL CRANKSHAFT POSITION SENSOR (See page [ES-403](#))

11. INSTALL CRANKSHAFT DAMPER SUB-ASSEMBLY
(See page [LU-26](#))
12. INSTALL ENGINE MOUNTING INSULATOR SUB-ASSEMBLY RH (See page [LU-26](#))
13. INSTALL CYLINDER HEAD COVER SUB-ASSEMBLY
(See page [FU-19](#))
14. CONNECT VENTILATION HOSE NO. 2 (See page [FU-20](#))
15. CONNECT VENTILATION HOSE (See page [FU-20](#))
16. INSTALL IGNITION COIL NO. 1 (See page [IG-9](#))
17. INSTALL GENERATOR ASSEMBLY (See page [CH-17](#))
18. INSTALL FAN AND GENERATOR V BELT (See page [EM-7](#))
19. ADJUST FAN AND GENERATOR V BELT (See page [EM-7](#))
20. INSPECT FAN AND GENERATOR V BELT (See page [EM-8](#))
21. CONNECT CABLE TO NEGATIVE BATTERY TERMINAL
Torque: 5.4 N*m (55 kgf*cm, 48 in.*lbf)
22. ADD ENGINE OIL
23. ADD ENGINE COOLANT (See page [CO-8](#))
24. CHECK ENGINE OIL LEVEL (See page [LU-1](#))
25. CHECK FOR ENGINE OIL LEAKAGE
26. CHECK FOR ENGINE COOLANT LEAKAGE (See page [CO-1](#))
27. INSTALL CYLINDER HEAD COVER NO. 2 (See page [IG-10](#))
28. INSTALL ENGINE UNDER COVER RH
29. INSTALL FRONT WHEEL RH
Torque: 103 N*m (1050 kgf*cm, 76 ft.*lbf)

CAMSHAFT COMPONENTS

EM

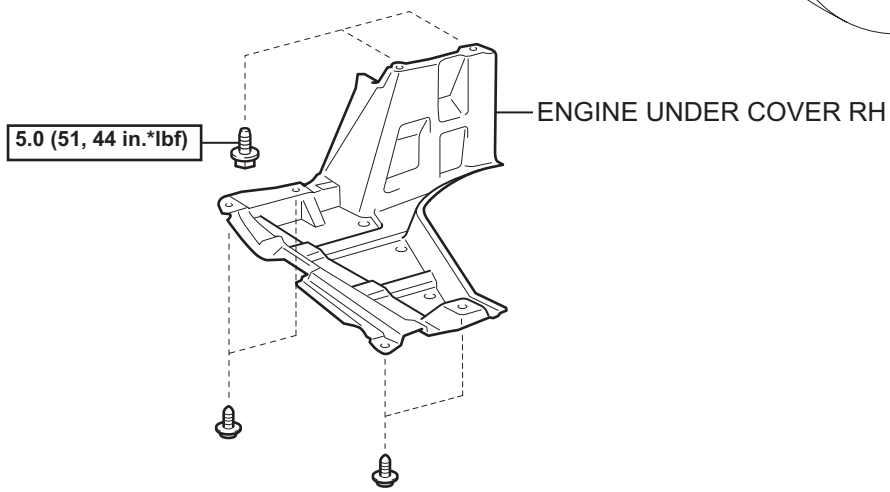
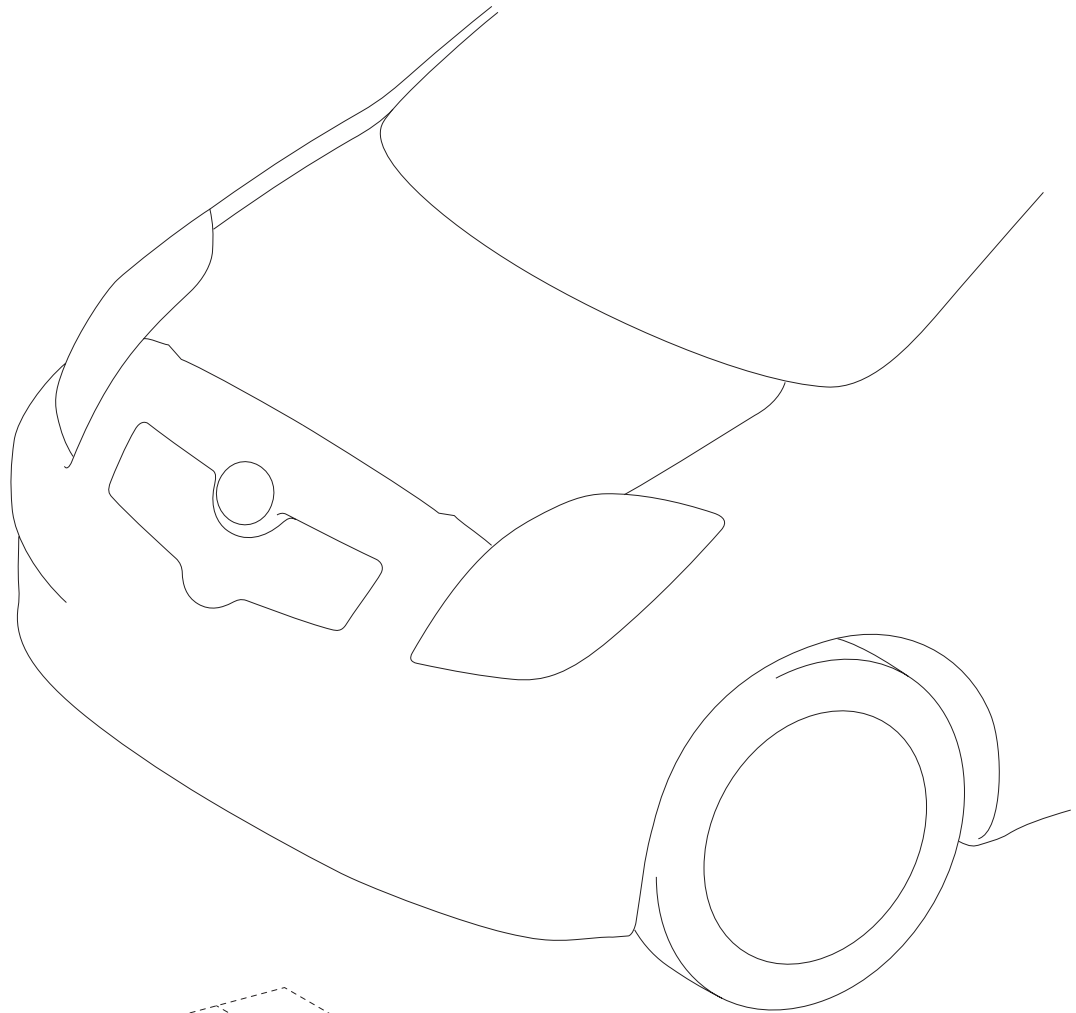

N*m (kgf*cm, ft.*lbf) : Specified torque

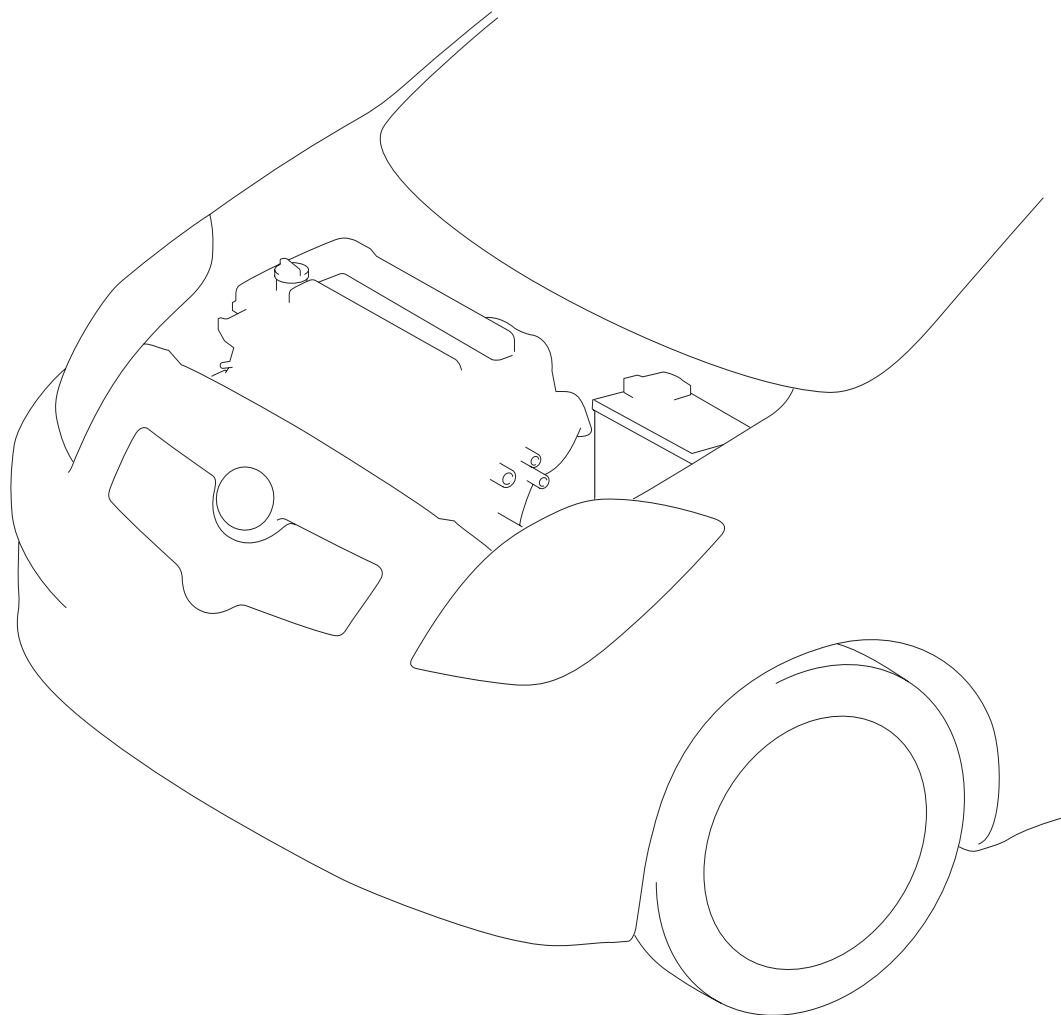
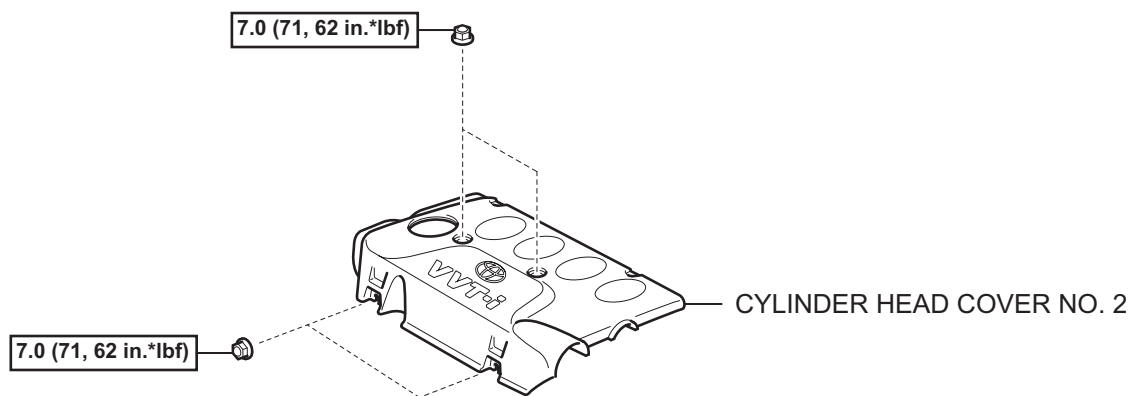

N*m (kgf*cm, ft.*lbf) : Specified torque

T

EM

for Hatchback:

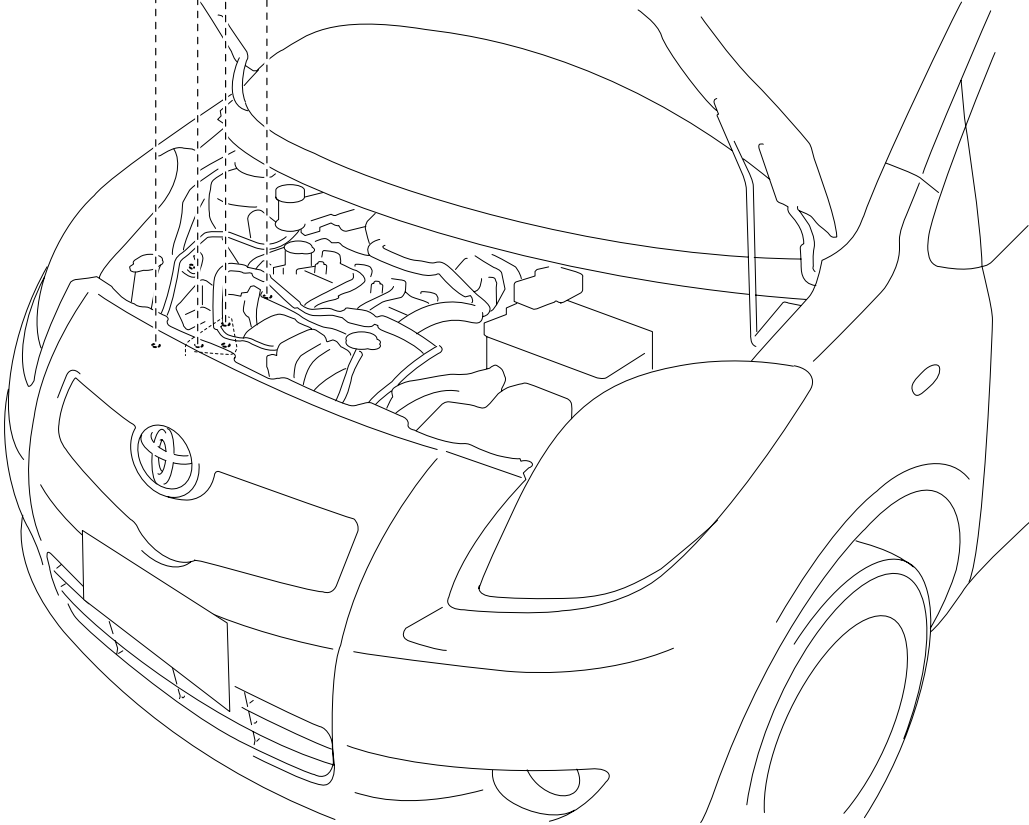
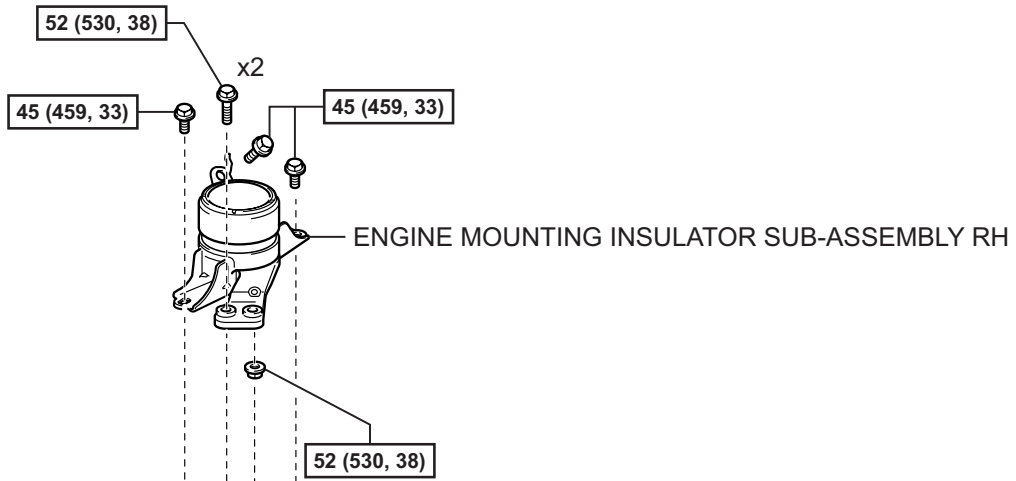

N*m (kgf*cm, ft.*lbf) : Specified torque

EM

for Sedan:

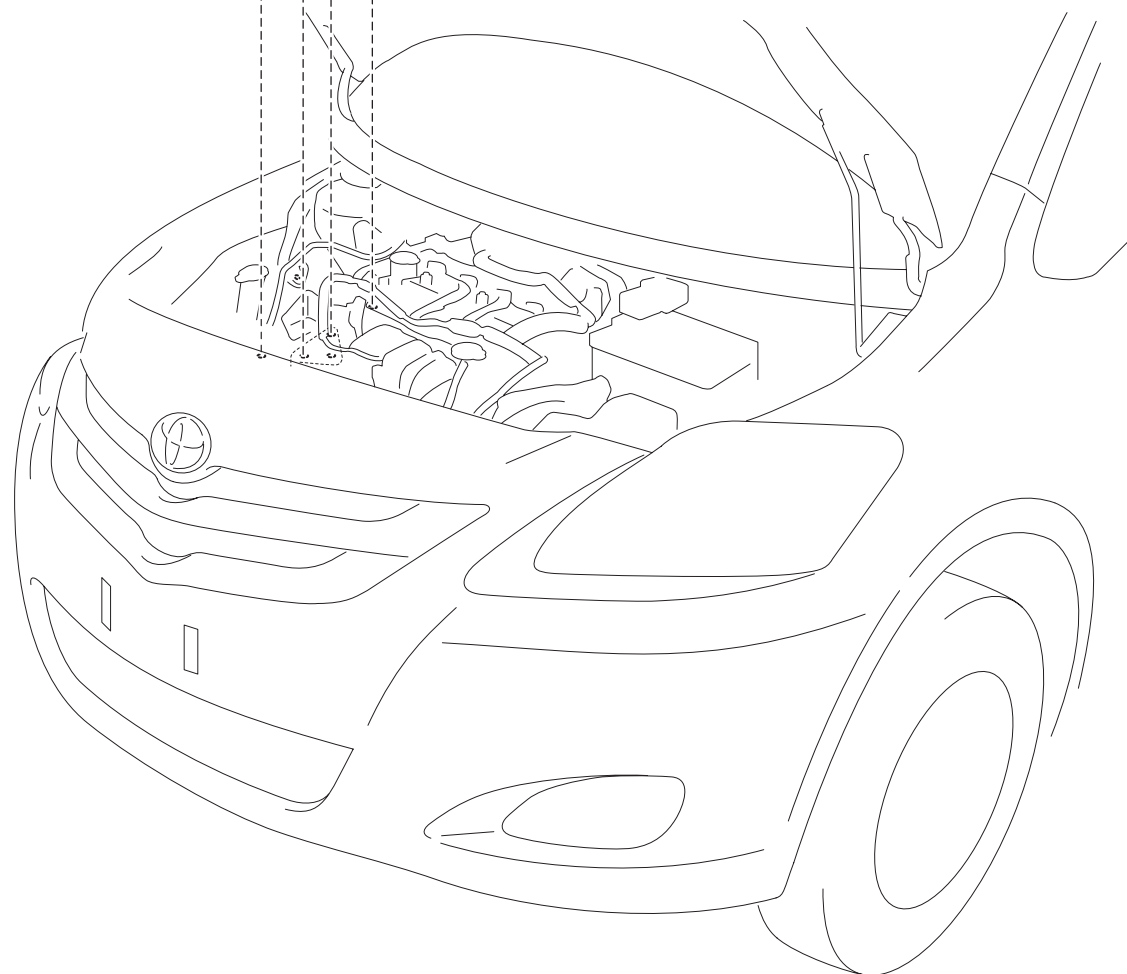
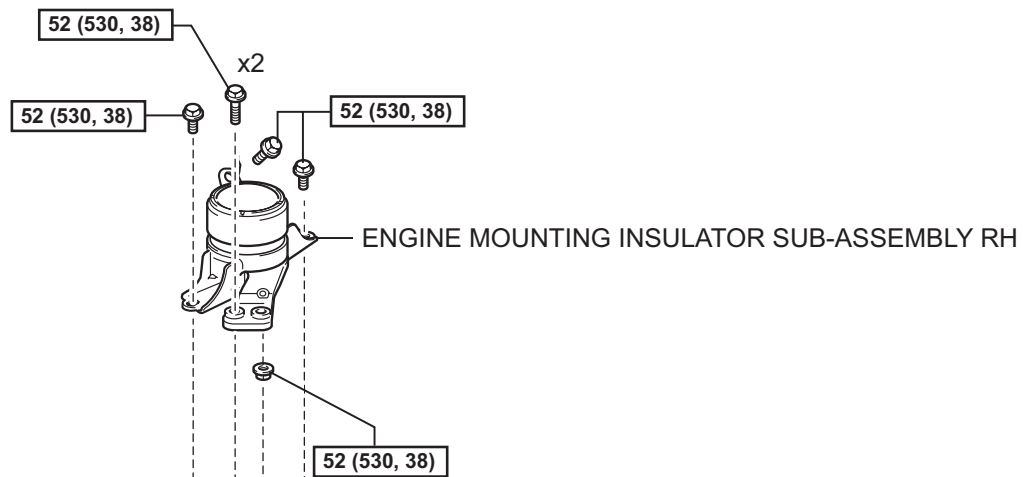

N*m (kgf*cm, ft*lbf) : Specified torque

EM

EM

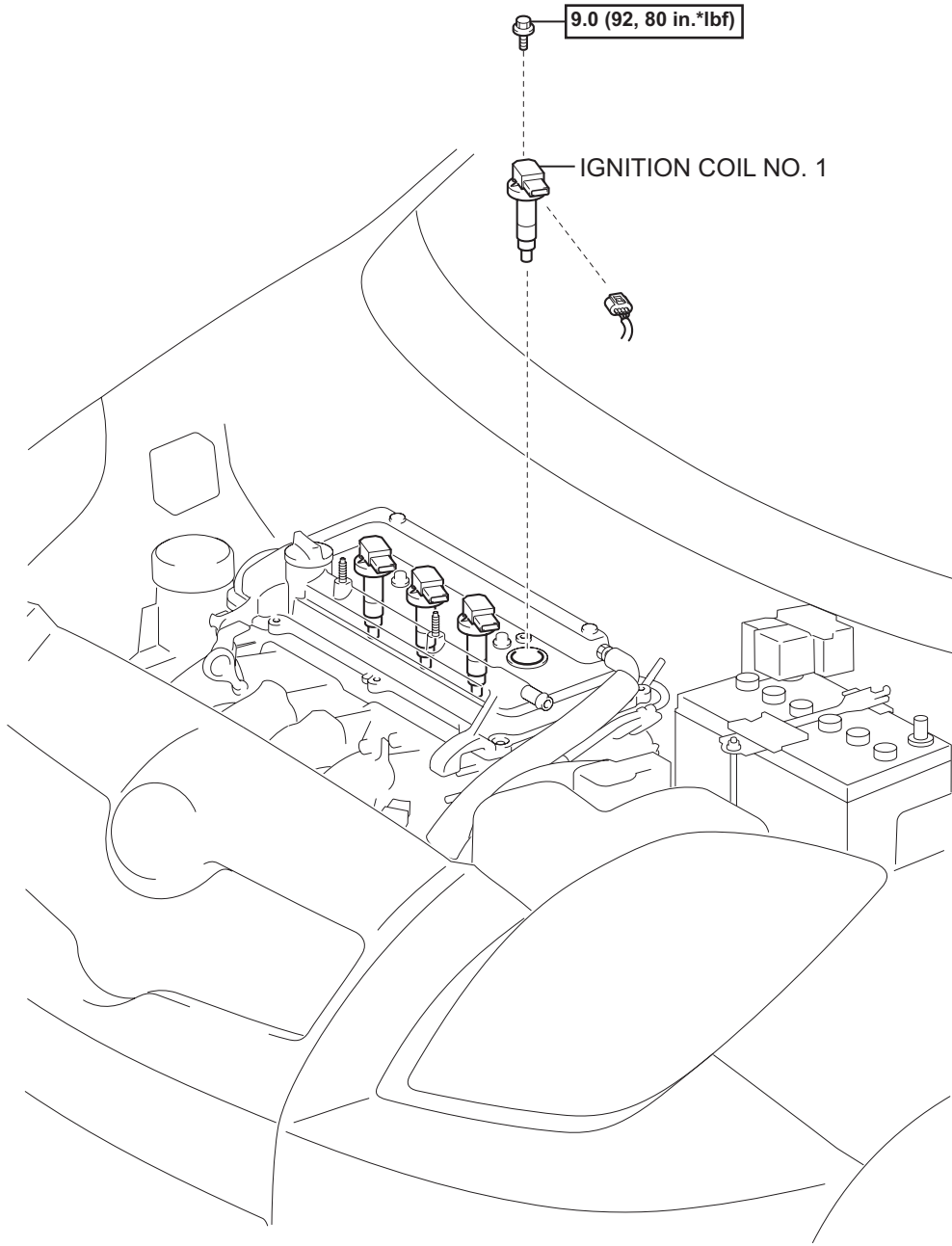

N*m (kgf*cm, ft.*lbf) : Specified torque

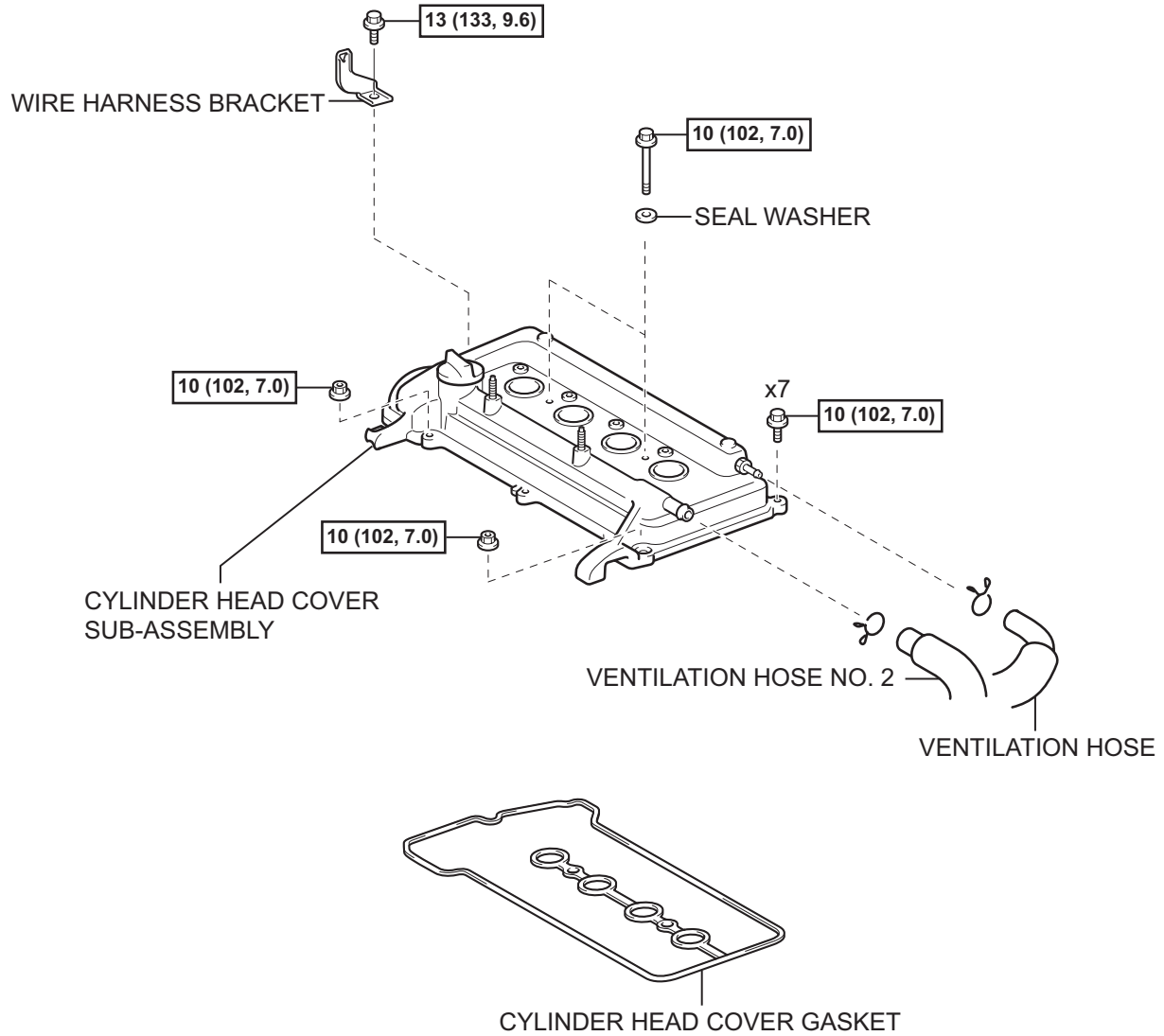

N*m (kgf*cm, ft.*lbf) : Specified torque

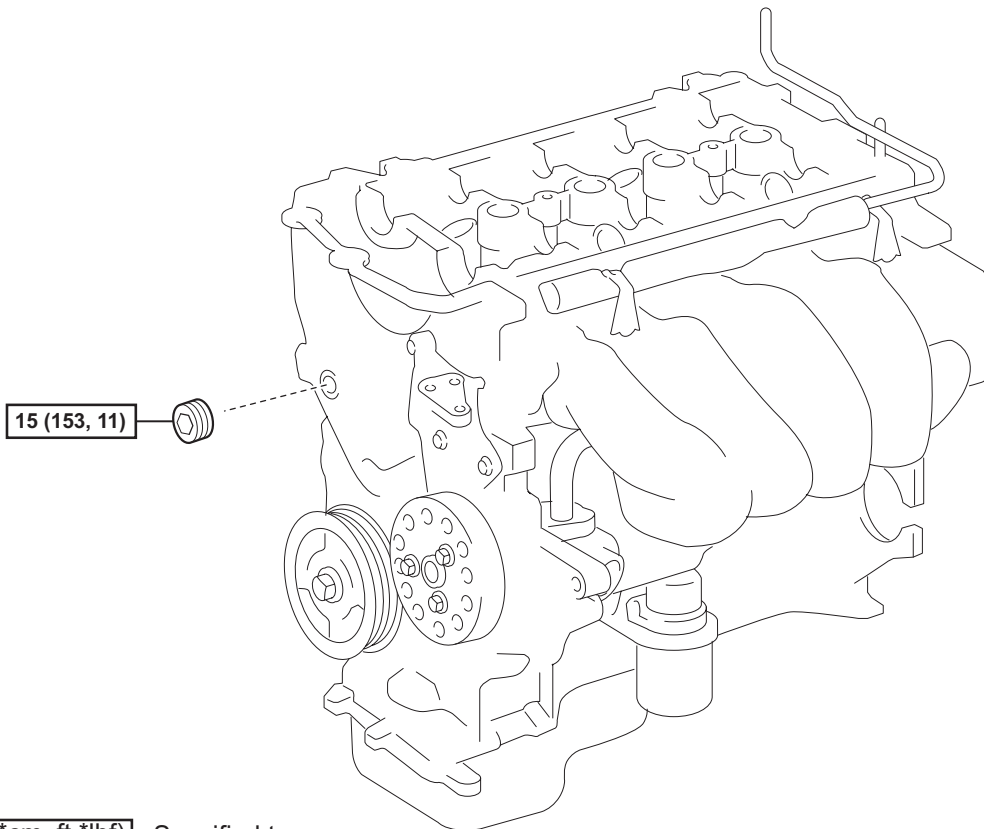
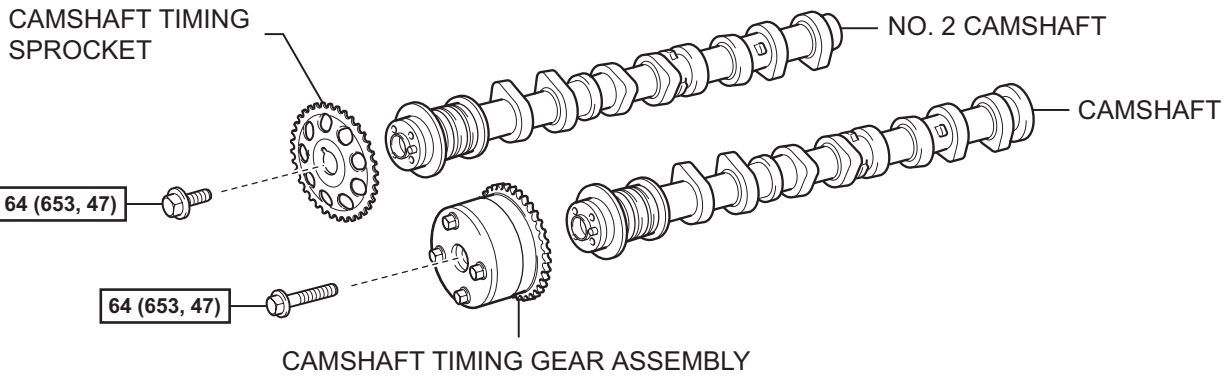
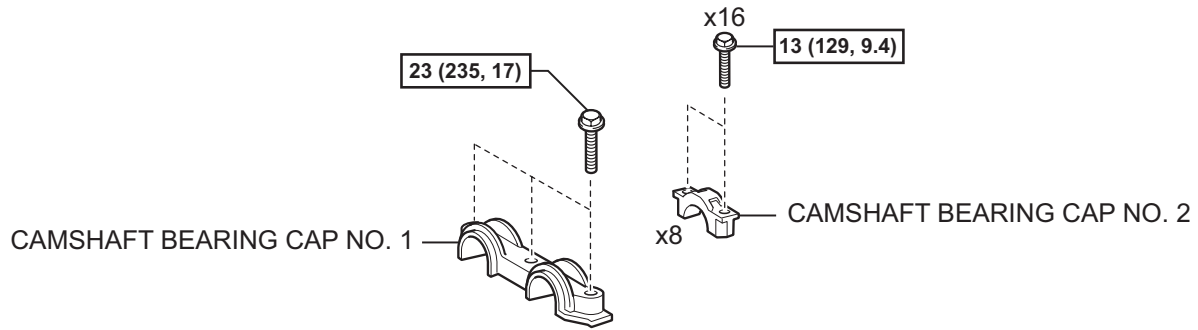

N*m (kgf*cm, ft.*lbf) : Specified torque

EM

REMOVAL

1. DISCONNECT CABLE FROM NEGATIVE BATTERY TERMINAL
2. REMOVE ENGINE UNDER COVER RH
3. REMOVE CYLINDER HEAD COVER NO. 2 (See page [IG-9](#))
4. REMOVE IGNITION COIL NO. 1 (See page [IG-9](#))
5. DISCONNECT VENTILATION HOSE (See page [FU-13](#))
6. DISCONNECT VENTILATION HOSE NO. 2 (See page [FU-13](#))
7. REMOVE CYLINDER HEAD COVER SUB-ASSEMBLY (See page [FU-13](#))
8. REMOVE FAN AND GENERATOR V BELT (See page [EM-7](#))
9. REMOVE ENGINE MOUNTING INSULATOR SUB-ASSEMBLY RH (See page [LU-17](#))
10. REMOVE NO. 2 CAMSHAFT

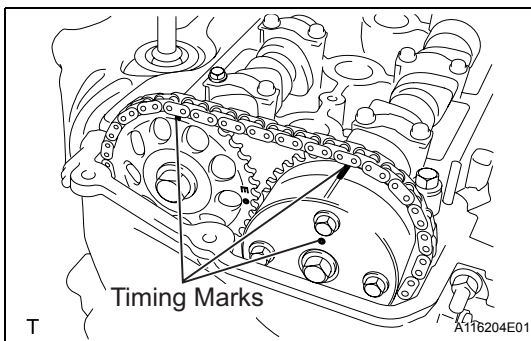
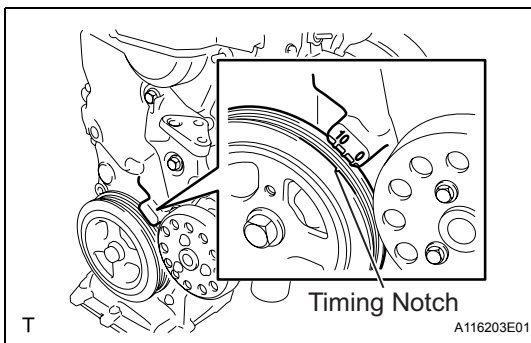
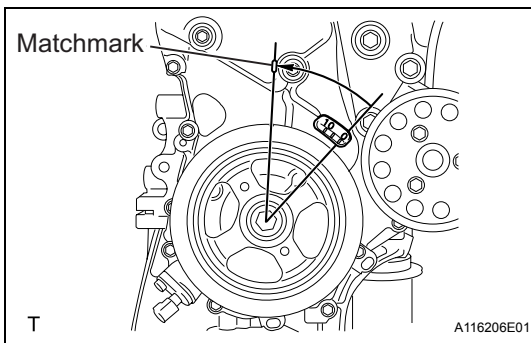

NOTICE:

When rotating the camshaft with the timing chain removed, rotate the crankshaft damper counterclockwise 40 ° from the TDC and align its timing notch with the matchmark of the timing chain cover to prevent the pistons from coming into contact with the valves.

- (a) Set the No. 1 cylinder to TDC / compression.
 - (1) Turn the crankshaft damper, and align its timing notch with the timing mark "0" of the oil pump.

- (2) Check that the timing marks on both the camshaft timing sprocket and the camshaft timing gear are facing upward, as shown in the illustration.

HINT:

If not, turn the crankshaft 1 complete revolution (360°) and align the marks as above.

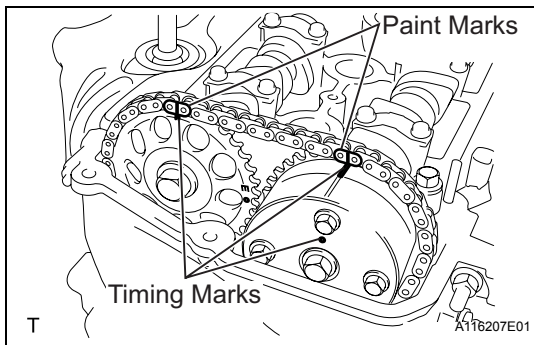

- (b) Place paint marks on the chain in the places where the timing marks of the camshaft timing sprocket and the camshaft timing gear are located.

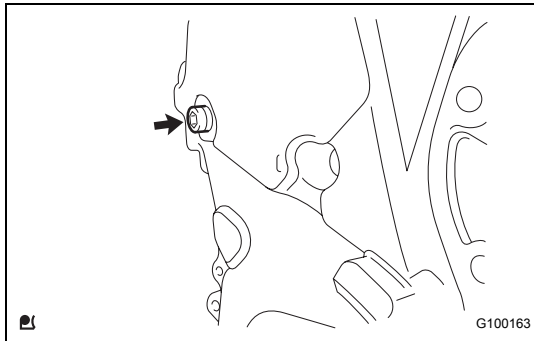

- (c) Using an 8 mm hexagon wrench, remove the screw plug.

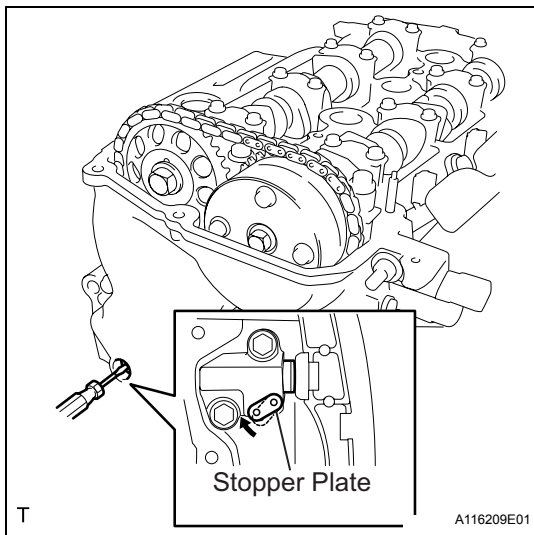

- (d) Insert a screwdriver into the service hole in the chain tensioner to pull the stopper plate of the chain tensioner upward.

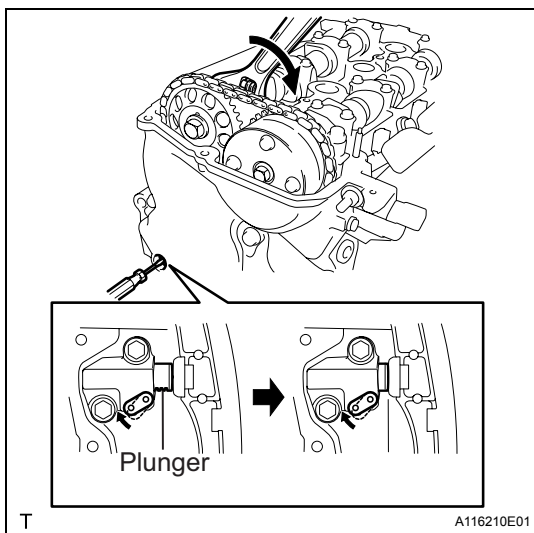

- (e) Using a wrench, rotate camshaft No. 2 clockwise to push in the plunger of the chain tensioner.

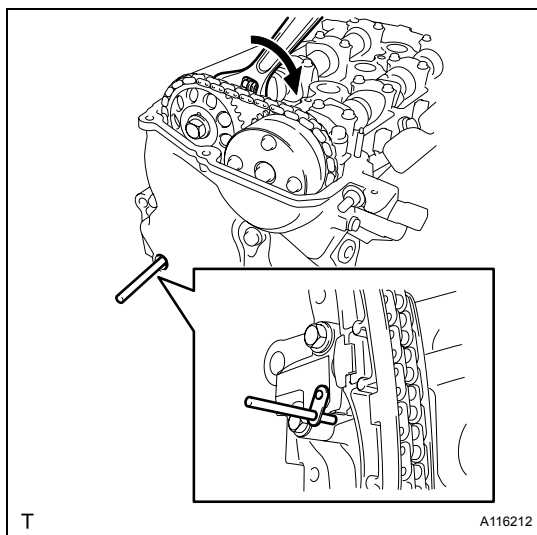

- (f) Remove the screwdriver from the service hole, then align the hole in the stopper plate with the service hole and insert a 3 mm (0.12 in.) diameter bar into the holes to hold the stopper plate.

HINT:

- Fix the stopper plate using the bar while rotating the camshaft right and left slightly.
- Hold the bar with tape so that it does not come off.

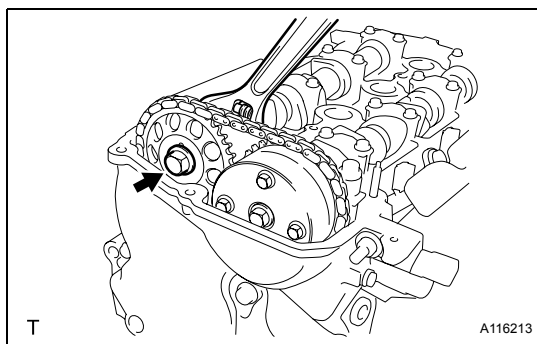

- (g) Using a wrench, hold the hexagonal lobe of camshaft No. 2 and remove the flange bolt.

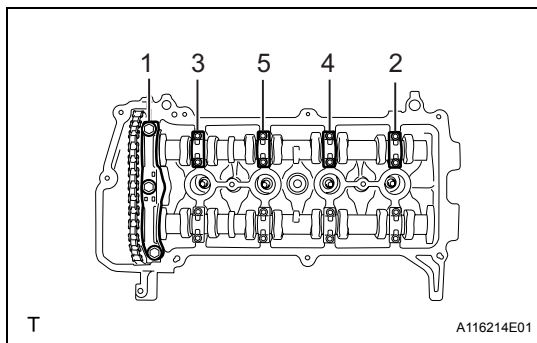

- (h) Using several steps, loosen and remove the 11 bearing cap bolts uniformly in the sequence shown in the illustration, then remove camshaft bearing caps No. 1 and No. 2.

NOTICE:

Loosen the bolts uniformly while keeping the camshaft level.

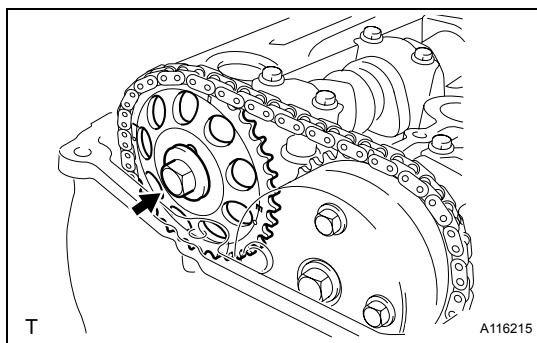

- (i) Remove the flange bolt and remove the camshaft timing sprocket.

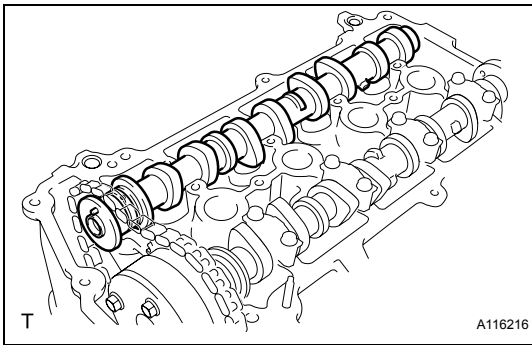

(j) Remove camshaft No. 2.

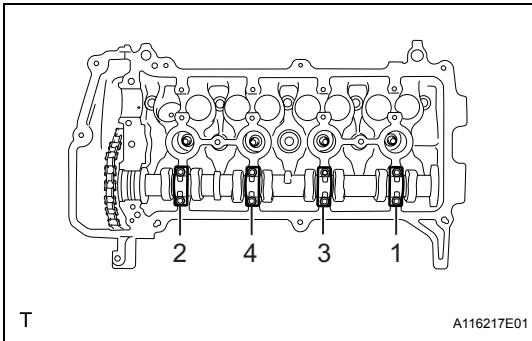

11. REMOVE CAMSHAFT

(a) Using several steps, loosen and remove the 8 bearing cap bolts uniformly in the sequence shown in the illustration, then remove camshaft bearing cap No. 2.

NOTICE:

Loosen each bolt uniformly while keeping the camshaft level.

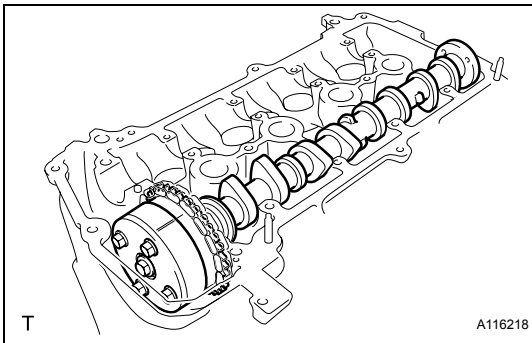

(b) Hold the chain by hand, and remove the camshaft and the camshaft timing gear assembly.

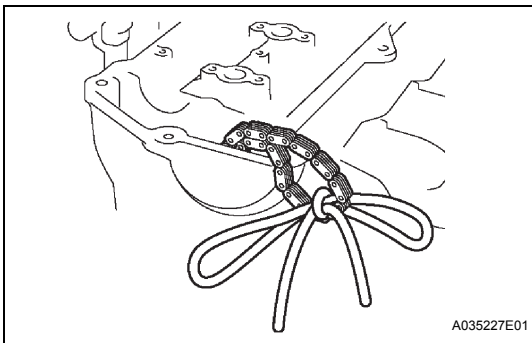

(c) Tie the chain with a piece of string as shown in the illustration.

12. REMOVE CAMSHAFT TIMING GEAR ASSEMBLY

(a) Clamp the camshaft in a vise and confirm that it is locked.

NOTICE:

Do not damage the camshaft.

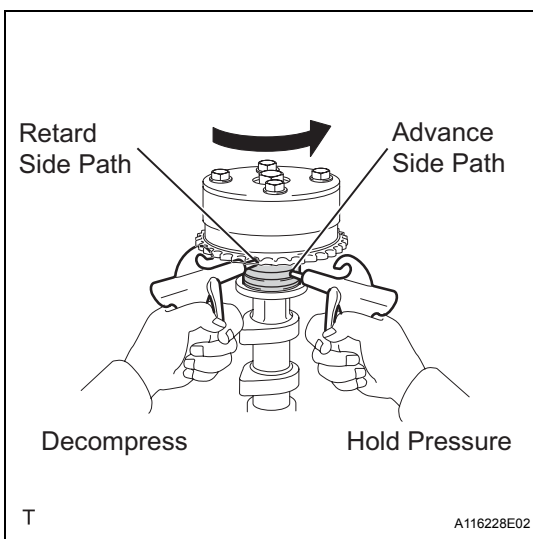
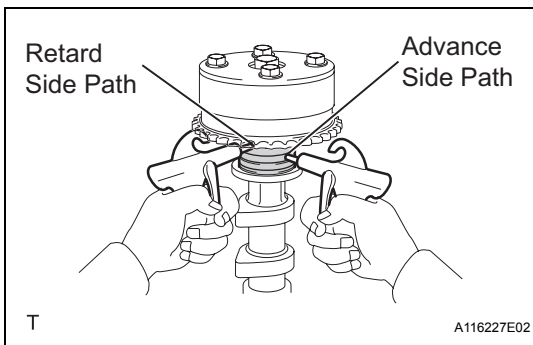
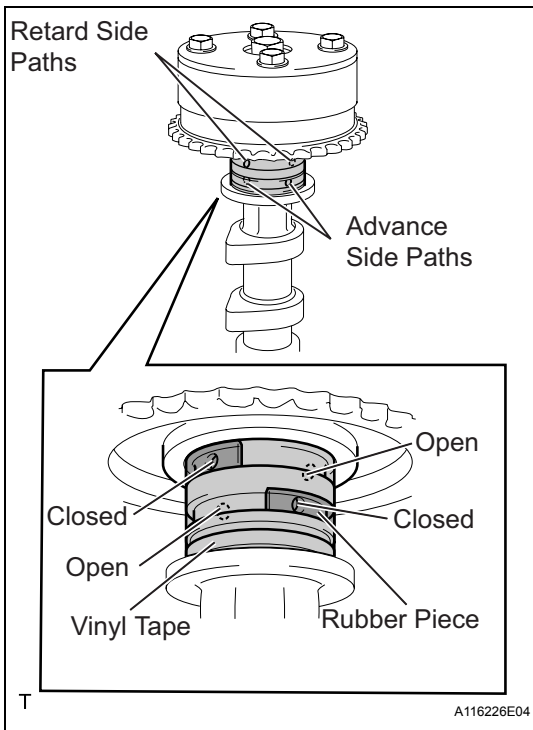

- (b) Cover the 4 oil paths of the cam journal with tape as shown in the illustration.

HINT:

One of the 2 grooves located on the cam journal is for retarding cam timing (upper) and the other is for advancing cam timing (lower). Each groove has 2 oil paths. Plug one of the oil paths for each groove with a piece of rubber before wrapping the cam journal with the tape.

- (c) Puncture the tape covering the advance oil path and the retard oil path on the opposite side from the advance oil path.

- (d) Apply air at about 150 kPa (1.5 kgf*cm²) pressure into the 2 broken paths (the advance side path and the retard side path).

NOTICE:

Cover the paths with a shop rag or piece of cloth to prevent oil splashes.

- (e) Confirm that the camshaft timing gear assembly revolves in the timing advance direction when the air pressure on the timing retard path is reduced.

HINT:

The lock pin is released, and the camshaft timing gear revolves in the advance direction.

- (f) When the camshaft timing gear reaches the most advanced position, release the air pressure on the timing retard side path, and then release the air pressure on the timing advance side path.

NOTICE:

The camshaft timing gear assembly occasionally shifts to the retard side abruptly, if the air pressure on the advance side path is released first. This often results in breakage of the lock pin.

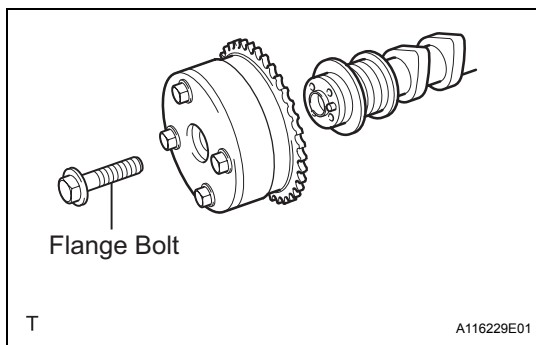

- (g) Remove the flange bolt and remove the camshaft timing gear assembly.

NOTICE:

- Do not remove the other 4 bolts.
- When reusing the camshaft timing gear, unlock the lock pin inside the camshaft timing gear first.

INSPECTION

1. INSPECT CAMSHAFT TIMING GEAR ASSEMBLY

- (a) Check the lock of camshaft timing gear.
 (1) Clamp the camshaft in a vice, and check that the camshaft timing gear is locked.

NOTICE:

Do not damage the camshaft.

- (b) Release the lock pin.

- (1) Cover the 4 oil paths of the cam journal with tape as shown in the illustration.

HINT:

One of the 2 grooves located on the cam journal is for retarding cam timing (upper) and the other is for advancing cam timing (lower). Each groove has 2 oil paths. Plug one of the oil paths for each groove with a piece of rubber before wrapping the cam journal with the tape.

- (2) Puncture the tape covering the advance oil path and the retard oil path on the opposite side from the advance oil path.

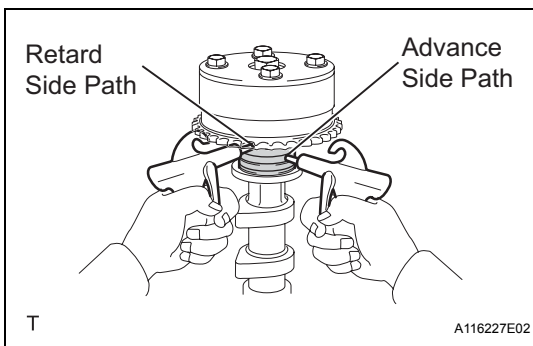
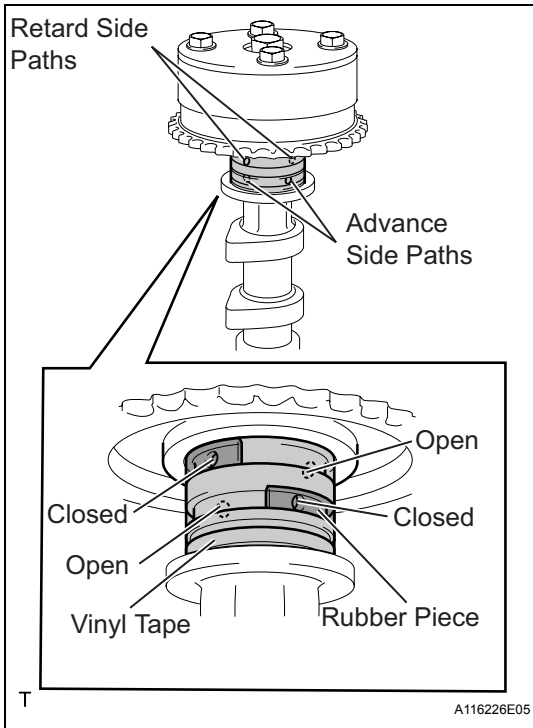

- (3) Apply air at about 150 kPa (1.5kgf*cm²) pressure into the 2 broken paths (the advance side path and the retard side path).

NOTICE:

Cover the paths with a shop rag or piece of cloth to prevent oil splashes.

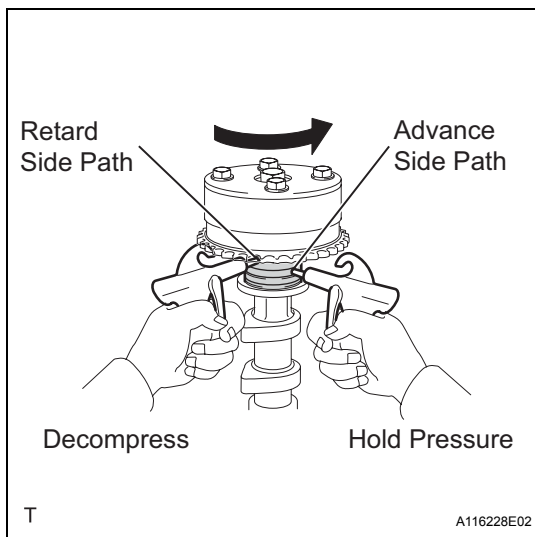

- (4) Confirm that the camshaft timing gear assembly revolves in the timing advance direction when the air pressure on the timing retard path is reduced.

HINT:

The lock pin is released and the camshaft timing gear revolves in the advance direction.

- (5) When the camshaft timing gear reaches the most advanced position, release the air pressure on the timing retard side path, and then release the air pressure on the timing advance side path.

NOTICE:

Camshaft timing gear assembly occasionally shifts to the retard side abruptly if the air pressure on the advance side path is released first. This often results in breakage of the lock pin.

- (c) Check the revolution.
- (1) Rotate the valve timing assembly back and forth several times, except where the lock pin meets it at the most retarded angle. Check the movable range and that it rotates smoothly.
- Standard:**
Smooth movable range is about 22.5°
- NOTICE:**
Perform this check by hand, instead of using air pressure.
- (d) Check that the gear locks in the most retarded position.
- (1) Confirm that the camshaft timing gear assembly is locked in the most retarded position.

INSTALLATION

1. INSTALL CAMSHAFT TIMING GEAR ASSEMBLY

NOTICE:

Install the camshaft timing gear assembly onto the camshaft with the lock pin of the camshaft timing gear assembly released.

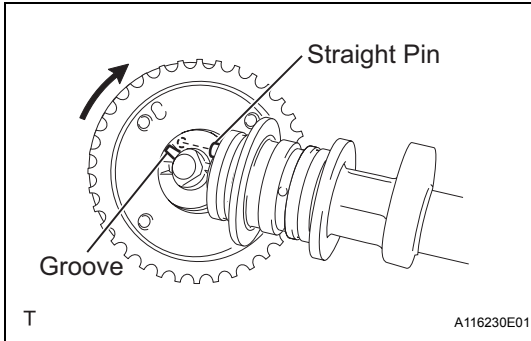

- Put the camshaft timing gear assembly and camshaft together with the straight pin of the groove.
- Turn the camshaft timing gear assembly clockwise while pushing it gently toward the camshaft. When the pin fits the groove, push to ensure a good fit.

NOTICE:

Do not turn the camshaft timing gear in the retard direction (clockwise).

- Check that there is no clearance between the gear flange and the camshaft.
- Tighten the flange bolt with the camshaft timing gear fixed.

Torque: 64 N*m (653 kgf*cm, 47 ft.*lbf)

NOTICE:

- Do not lock the camshaft timing gear assembly when tightening the bolt.
 - Release the lock pin of the camshaft timing gear assembly first, and tighten the bolt when the lock pin is locked in the most retarded position.
 - Tightening the bolts with the lock pin locked could cause breakage of the lock pin.
- Check that the camshaft timing gear assembly moves smoothly in the retard direction (clockwise) and is locked in the most retarded position.

2. INSTALL CAMSHAFT

- Apply a light coat of engine oil to the camshaft and camshaft journals.
- Install the chain onto the camshaft timing gear with the paint mark and the timing mark aligned as shown in the illustration.

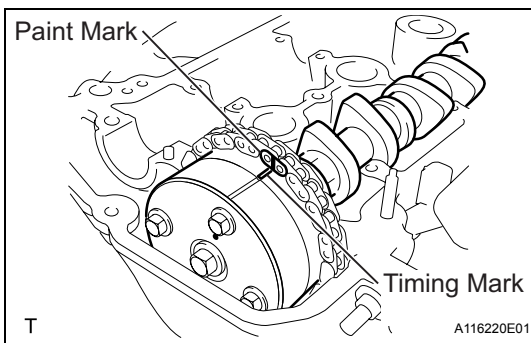

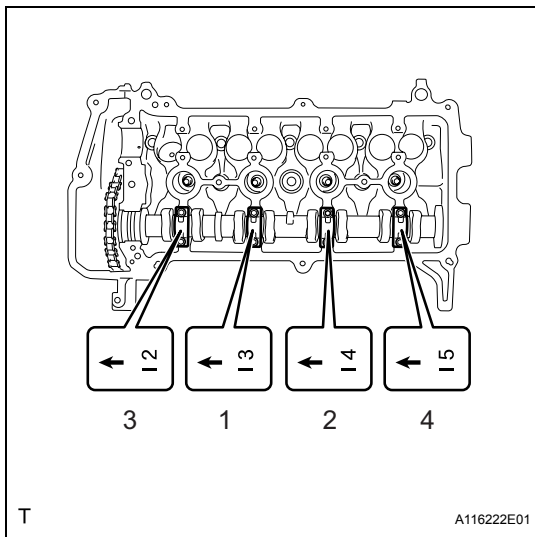

- (c) Examine the front marks and numbers on camshaft bearing cap No. 2 and check that the sequence is as shown in the illustration. Then uniformly tighten the bolts, in several steps, in the sequence shown in the illustration.

Torque: 13 N*m (129 kgf*cm, 9.4 ft.*lbf)

NOTICE:

Tighten each bolt uniformly while keeping the camshaft level.

EM

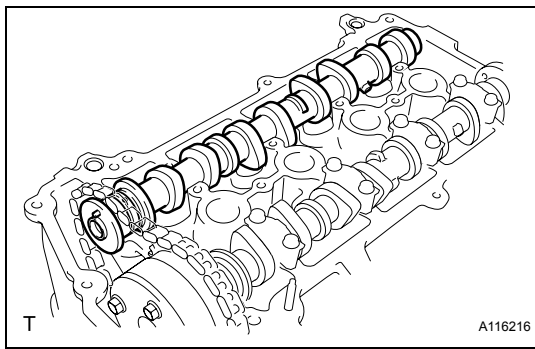

3. INSTALL NO. 2 CAMSHAFT

- (a) Install camshaft No. 2.

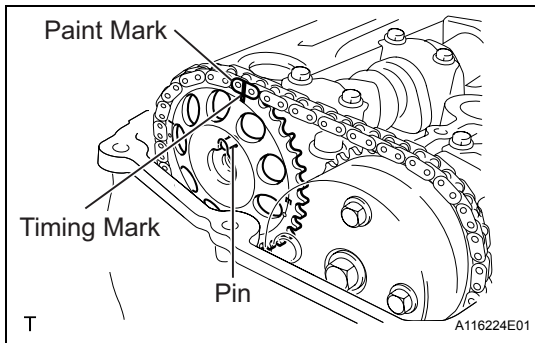

- (b) Hold the chain and align the timing mark on the camshaft timing sprocket with the paint mark of the chain.
- (c) Align the alignment pin hole in the camshaft timing sprocket with the alignment pin of the camshaft, and install the sprocket onto the camshaft.

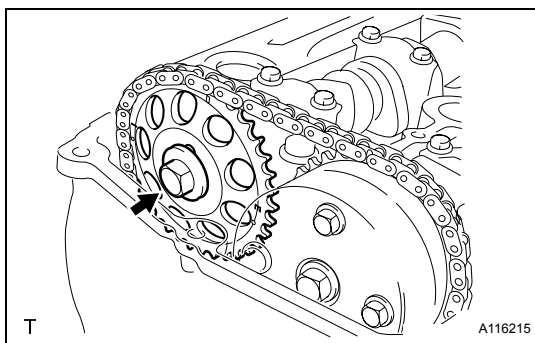

- (d) Provisionally install the flange bolt.

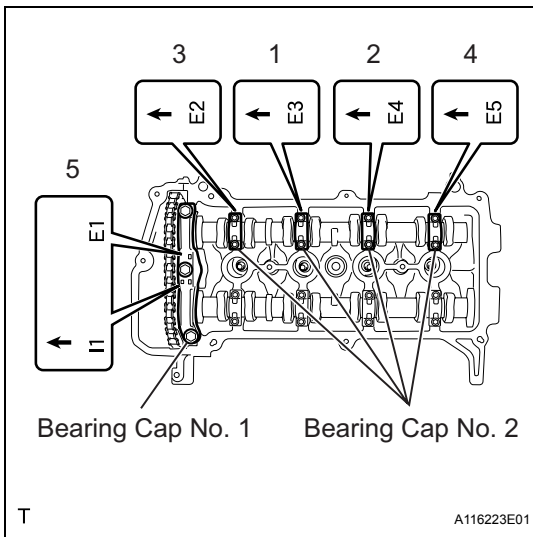

- (e) Examine the front marks and numbers on camshaft bearing caps No. 1 and No. 2 and check that the sequence is as shown in the illustration. Then uniformly tighten the bolts, in several steps, in the sequence shown in the illustration.

Torque: for bearing cap No. 2

13 N*m (129 kgf*cm, 9.4 ft.*lbf)

for bearing cap No. 1

23 N*m (235 kgf*cm, 17 ft.*lbf)

NOTICE:

Tighten each bolt uniformly while keeping the camshaft level.

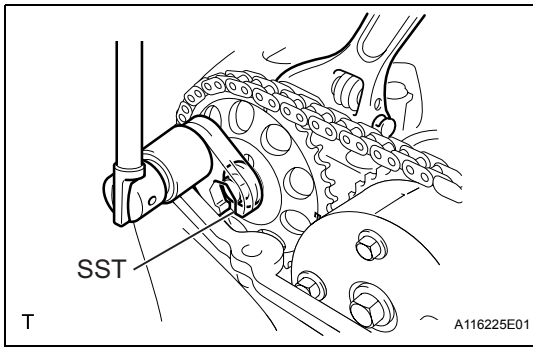

- (f) Using a wrench, hold the hexagonal lobe of camshaft No. 2 and install the flange bolt.

SST 09023-38400

Torque: 64 N*m (653 kgf*cm, 47 ft.*lbf)

- (g) Remove the bar from the timing chain tensioner.

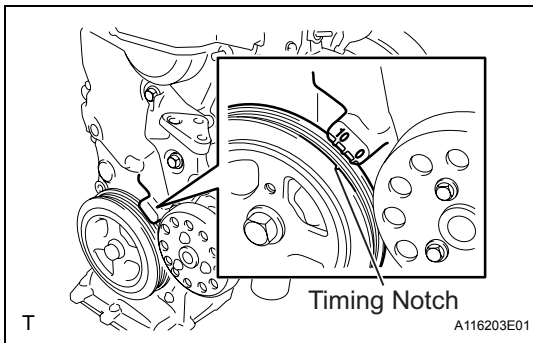

- (h) Turn the crankshaft damper and align its timing notch with the timing mark "0" of the oil pump.

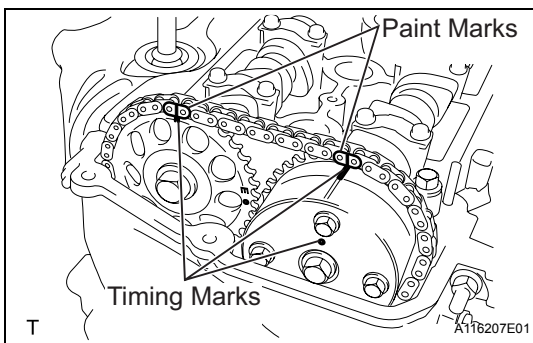

- (i) Check that all the pairs of timing marks are aligned.
 (j) Apply adhesive to the end 2 or 3 threads of the screw plug.

Adhesive:

Toyota Genuine Adhesive 1324, Three Bond 1324 or Equivalent

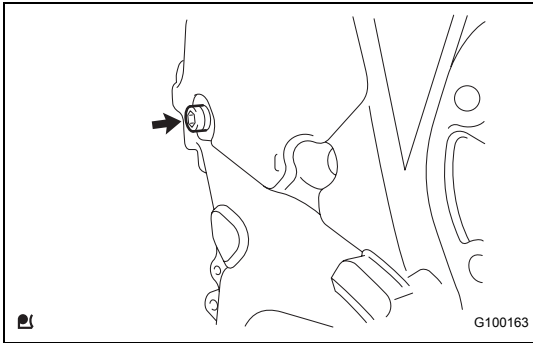

(k) Using an 8 mm hexagon wrench, install the screw plug.

Torque: 15 N*m (153 kgf*cm, 11 ft.*lbf)

4. **INSPECT VALVE CLEARANCE** (See page [EM-9](#))
5. **ADJUST VALVE CLEARANCE** (See page [EM-10](#))
6. **INSTALL ENGINE MOUNTING INSULATOR SUB-ASSEMBLY RH** (See page [LU-26](#))
7. **INSTALL FAN AND GENERATOR V BELT** (See page [EM-7](#))
8. **ADJUST FAN AND GENERATOR V BELT** (See page [EM-7](#))
9. **INSPECT FAN AND GENERATOR V BELT** (See page [EM-8](#))
10. **INSTALL CYLINDER HEAD COVER SUB-ASSEMBLY** (See page [FU-19](#))
11. **CONNECT VENTILATION HOSE NO. 2** (See page [FU-20](#))
12. **CONNECT VENTILATION HOSE** (See page [FU-20](#))
13. **INSTALL IGNITION COIL NO. 1** (See page [IG-9](#))
14. **CONNECT CABLE TO NEGATIVE BATTERY TERMINAL**
Torque: 5.4 N*m (55 kgf*cm, 48 in.*lbf)
15. **CHECK FOR ENGINE OIL LEAKAGE**
16. **INSTALL CYLINDER HEAD COVER NO. 2** (See page [IG-10](#))
17. **INSTALL ENGINE UNDER COVER RH**

CYLINDER HEAD

COMPONENTS

for Hatchback:

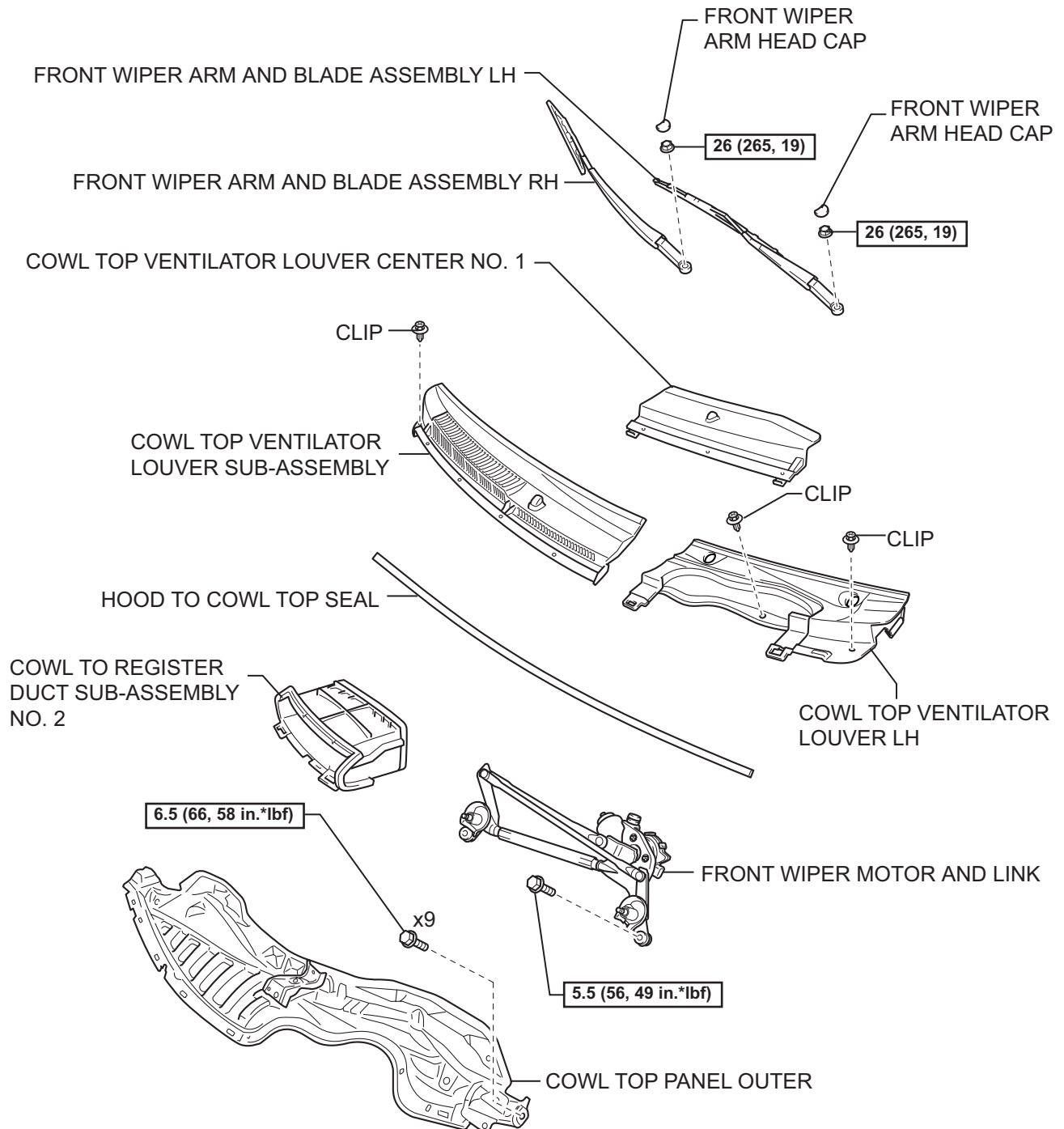

EM

N*m (kgf*cm, ft*lbf) : Specified torque

for Sedan:

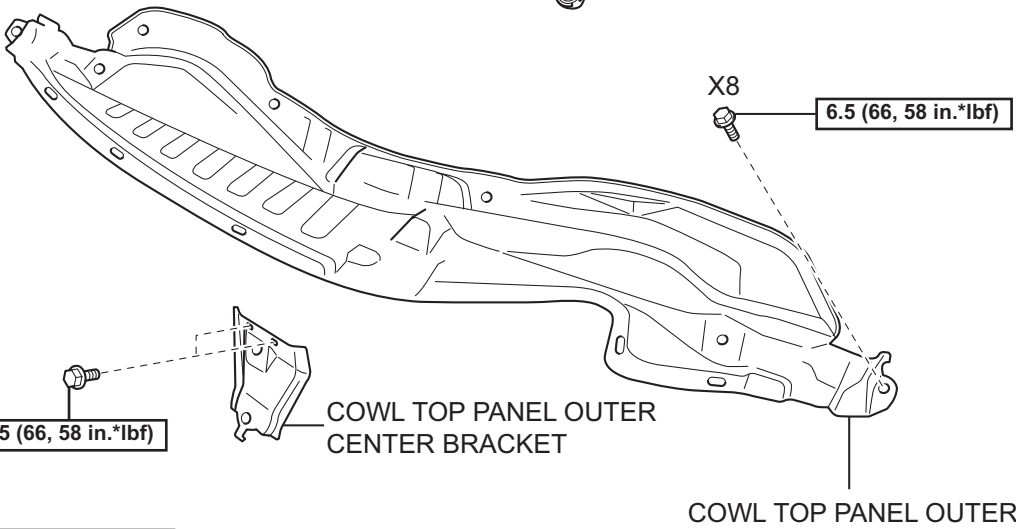
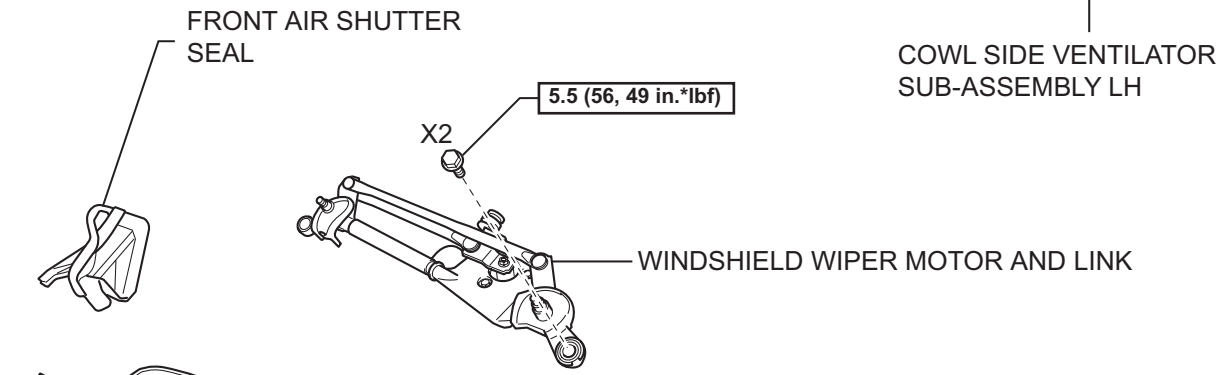
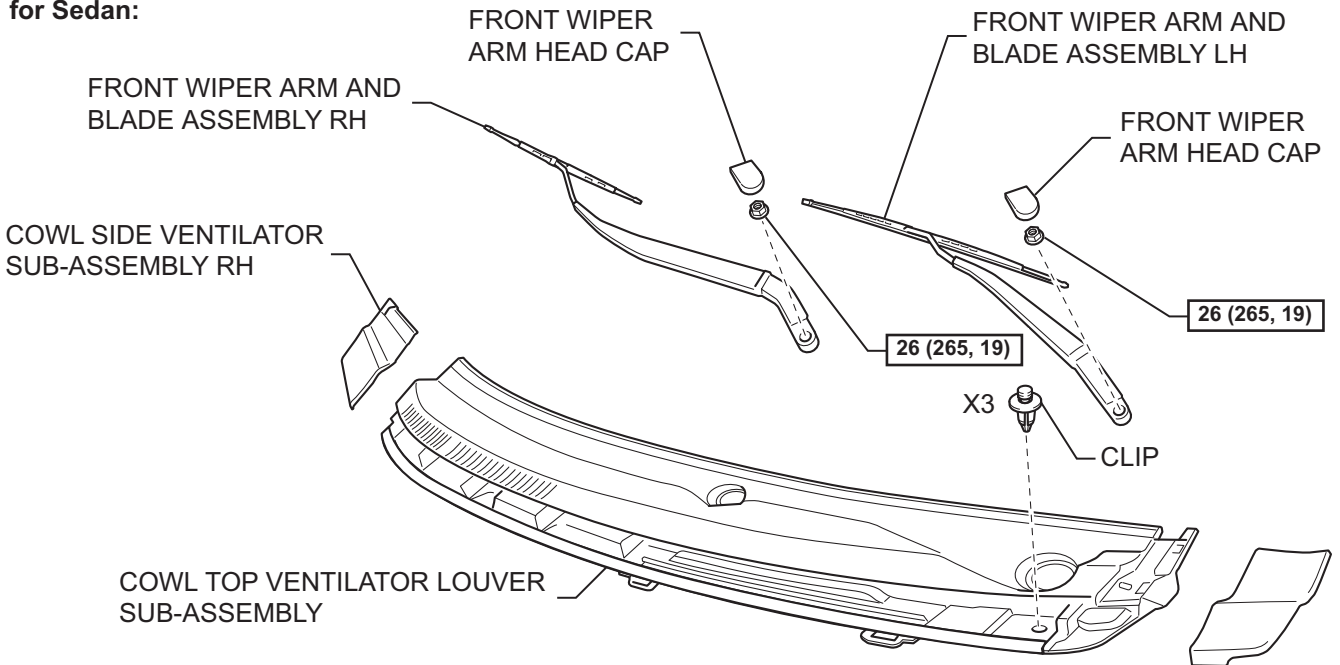

N*m (kgf*cm, ft.*lbf) : Specified torque

EM

Y

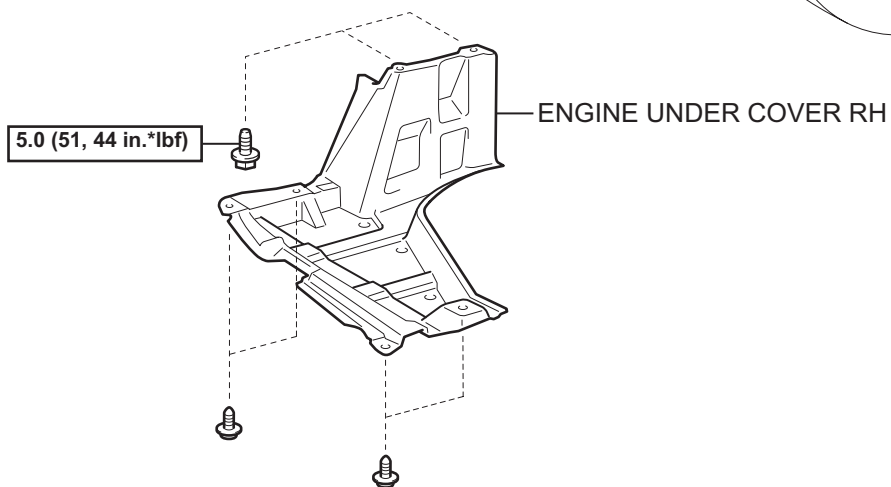
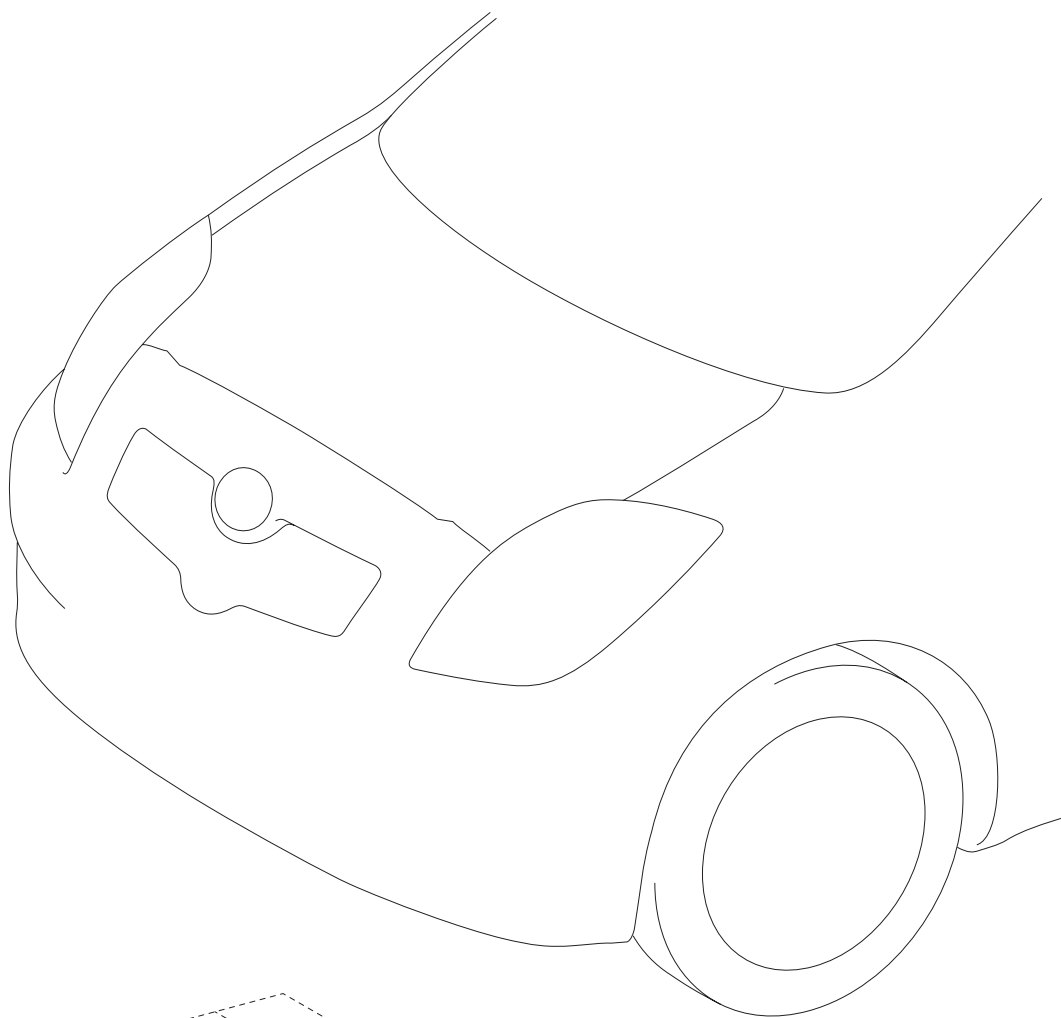

N*m (kgf*cm, ft.*lbf) : Specified torque

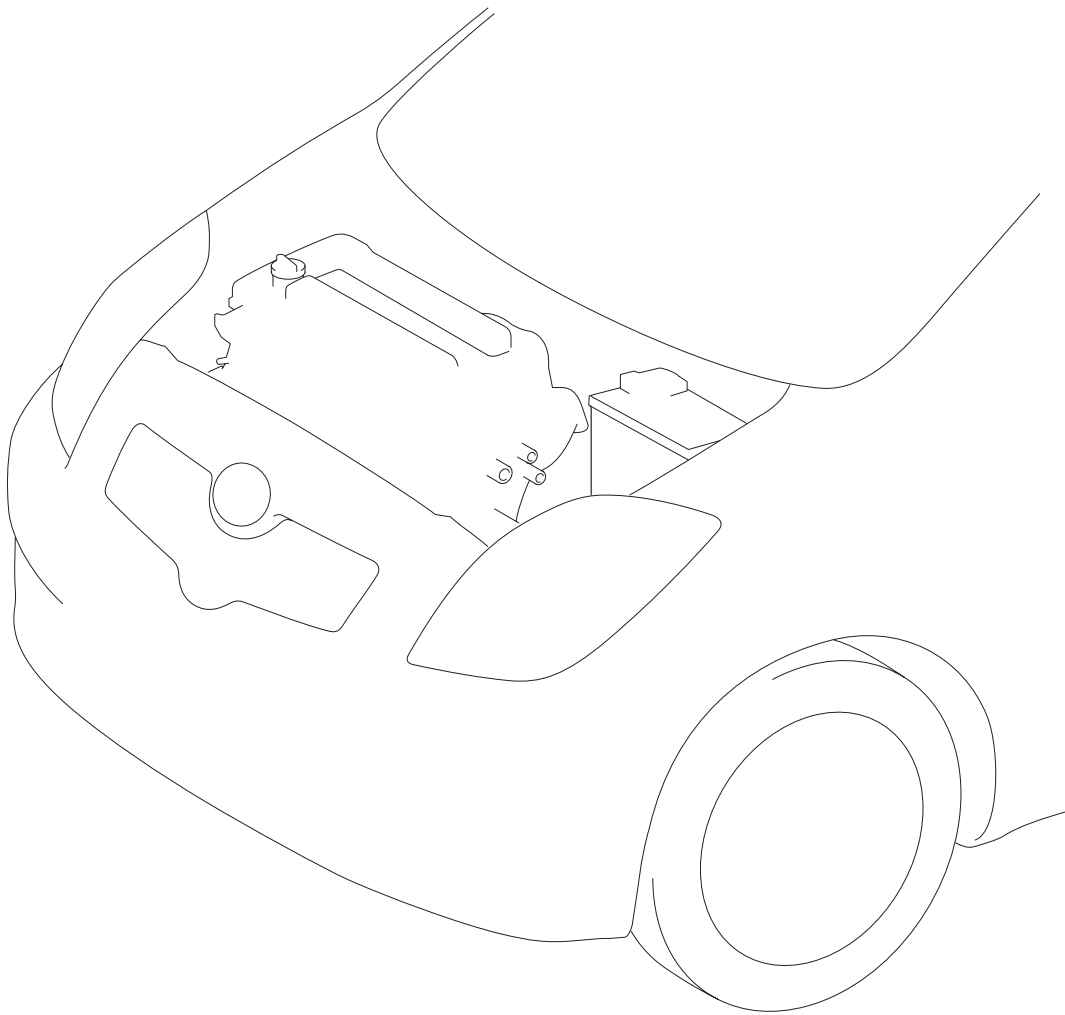
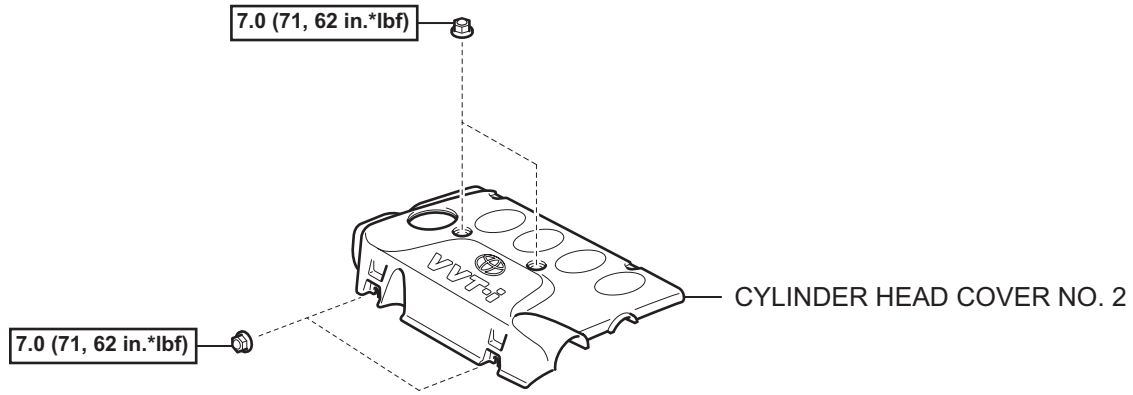

N*m (kgf*cm, ft.*lbf) : Specified torque

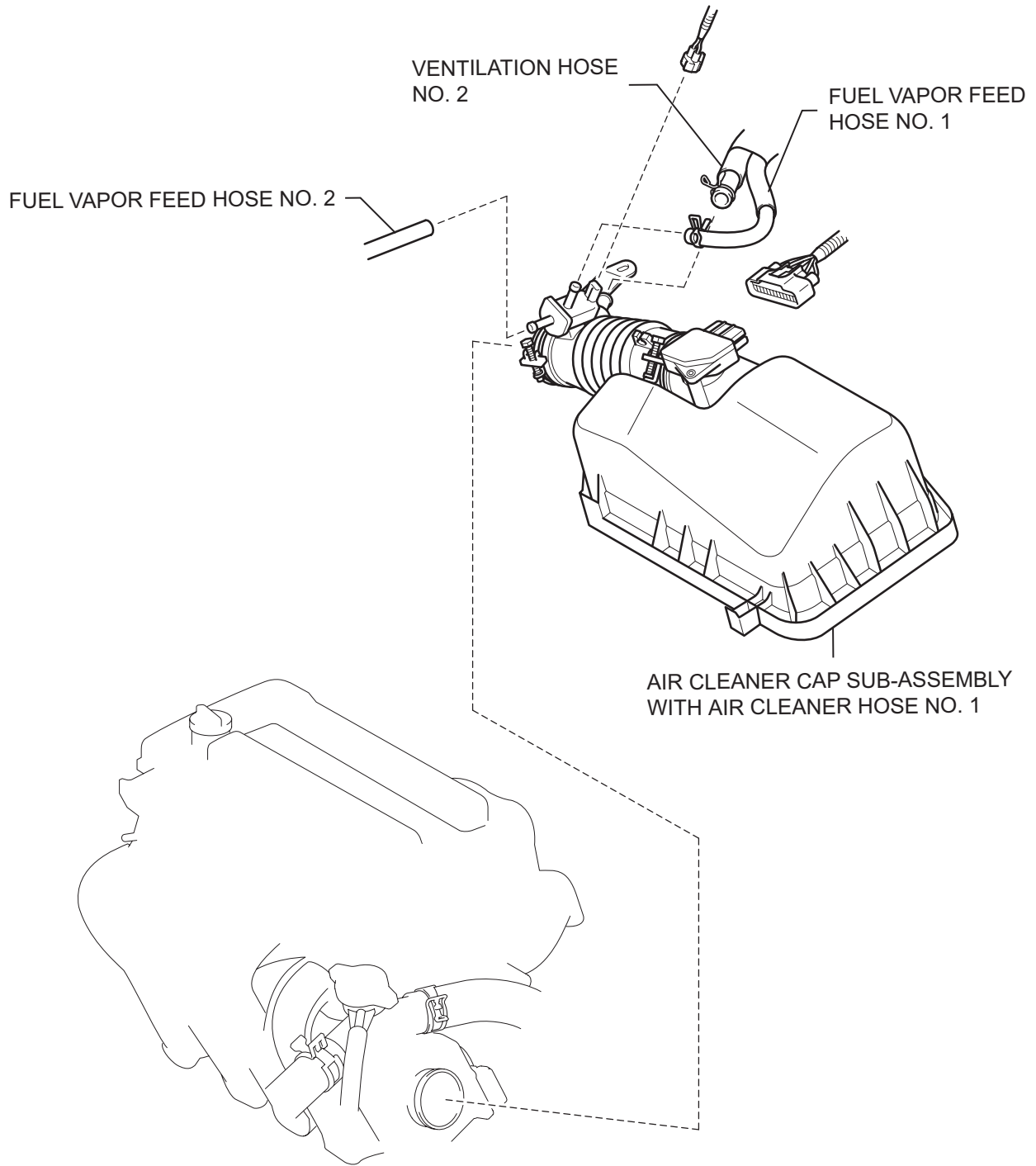

EM

EM

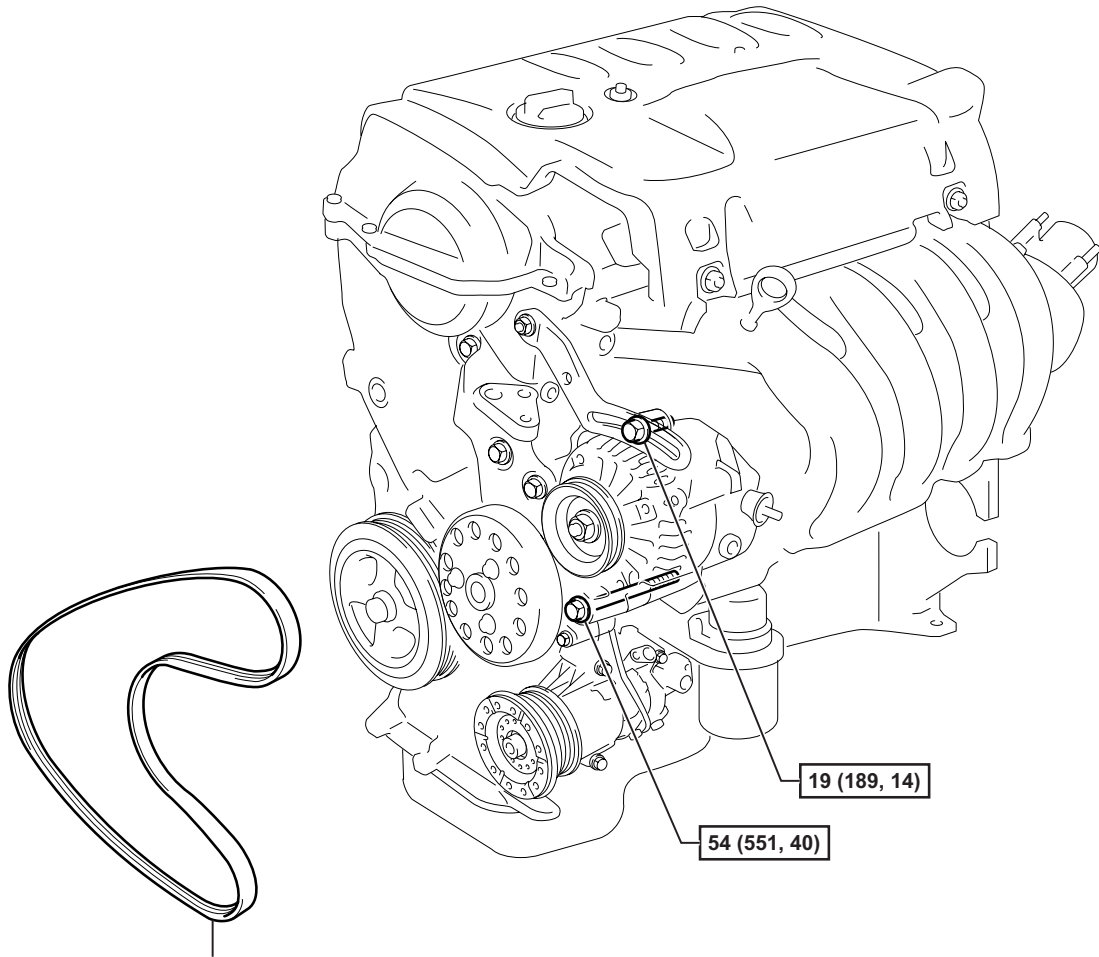

FAN AND GENERATOR V BELT

N*m (kgf*cm, ft.*lbf) : Specified torque

T

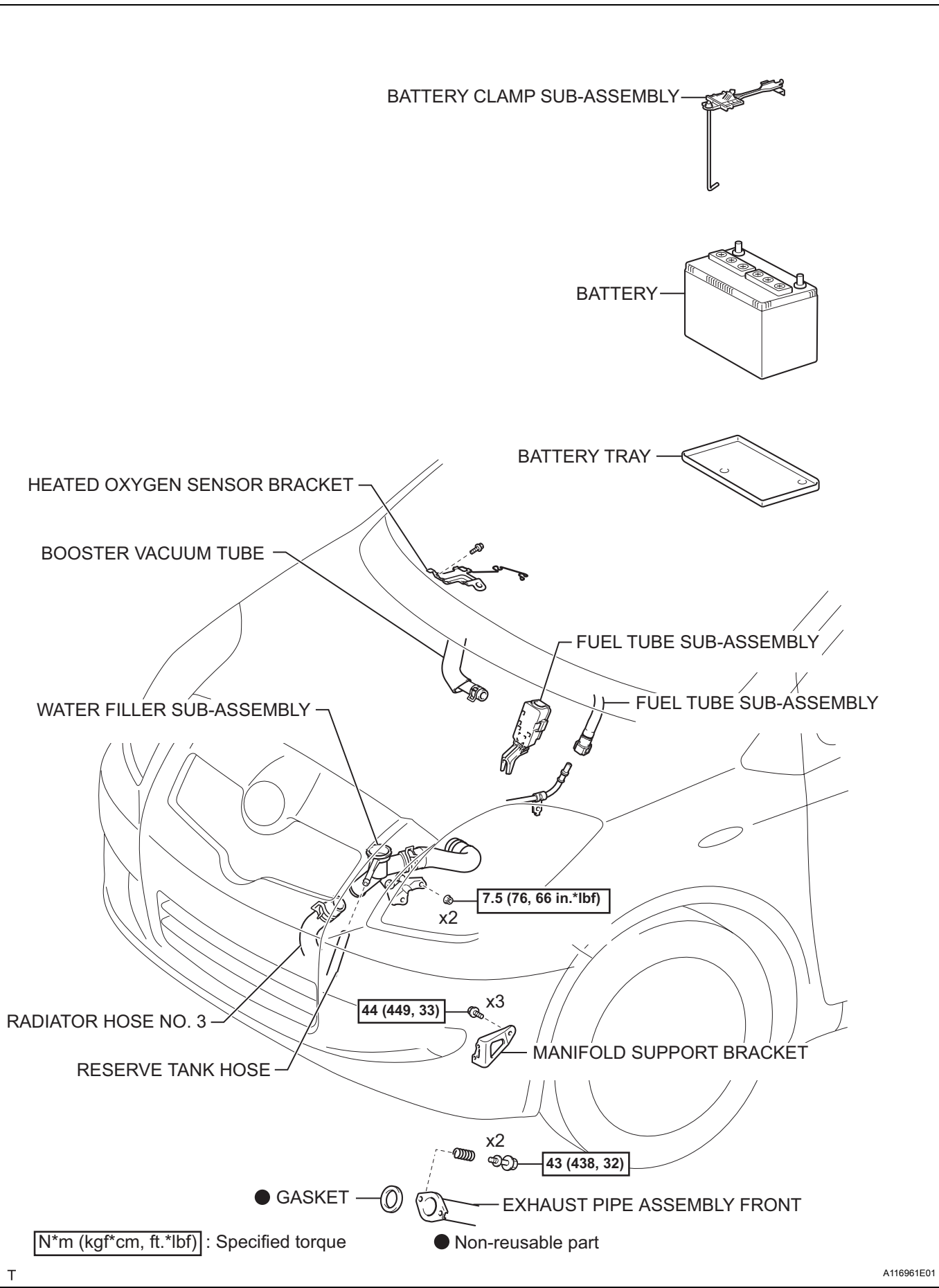

for Hatchback:

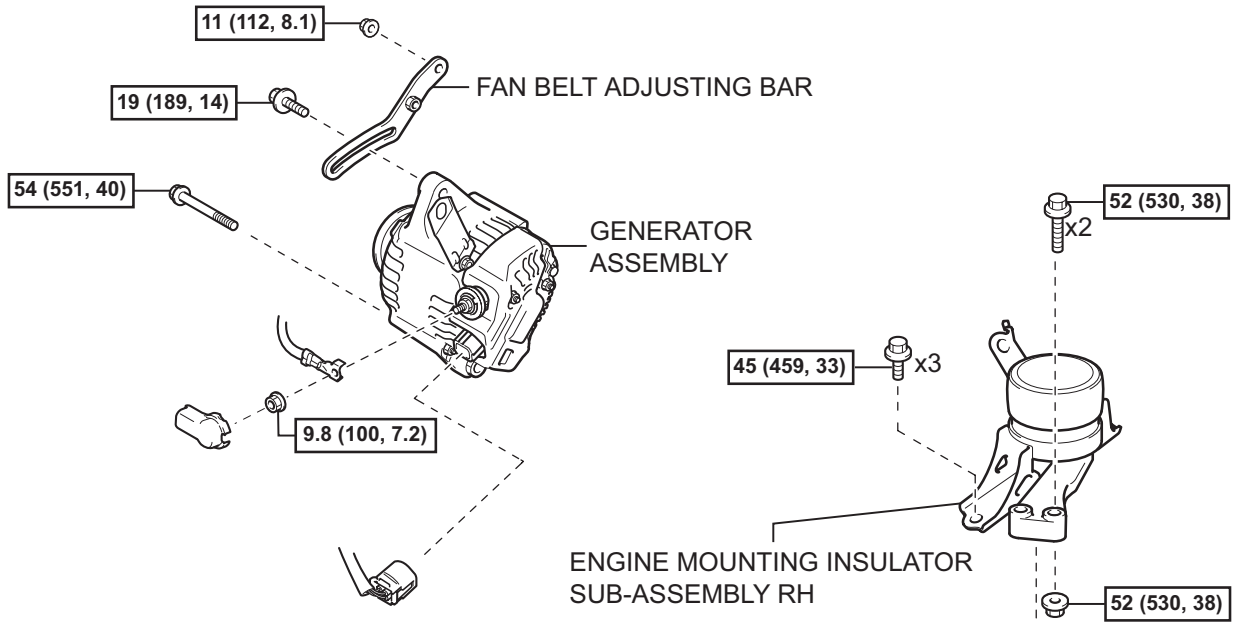

N*m (kgf*cm, ft.*lbf) : Specified torque

T

EM

for Sedan:

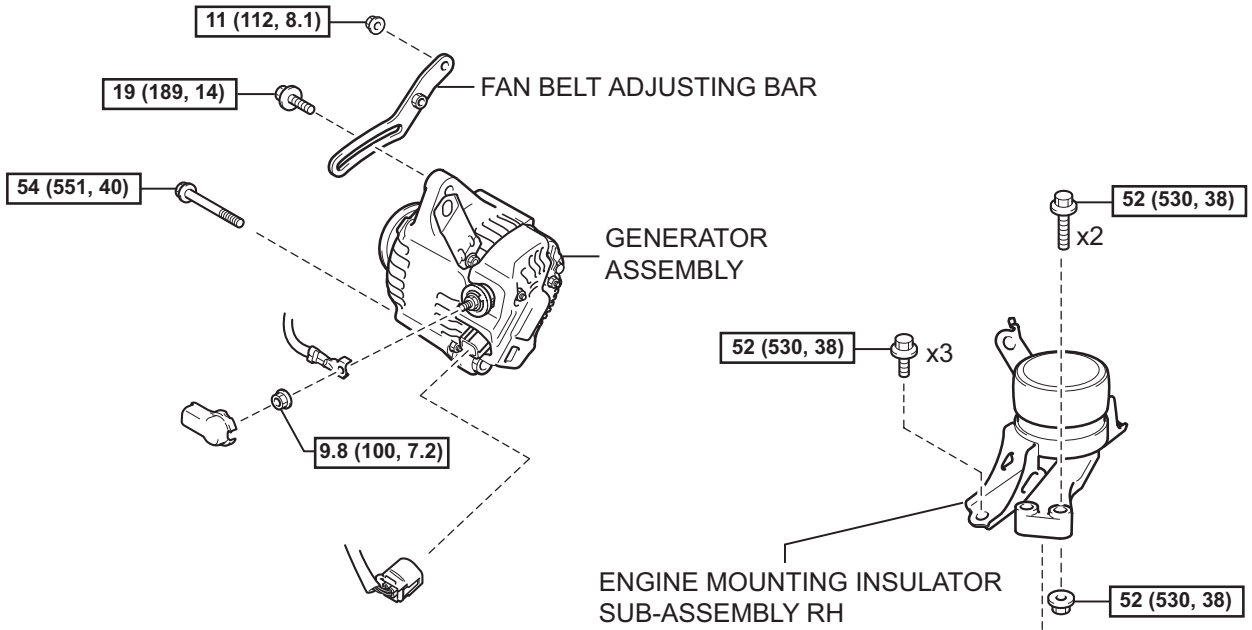

EM

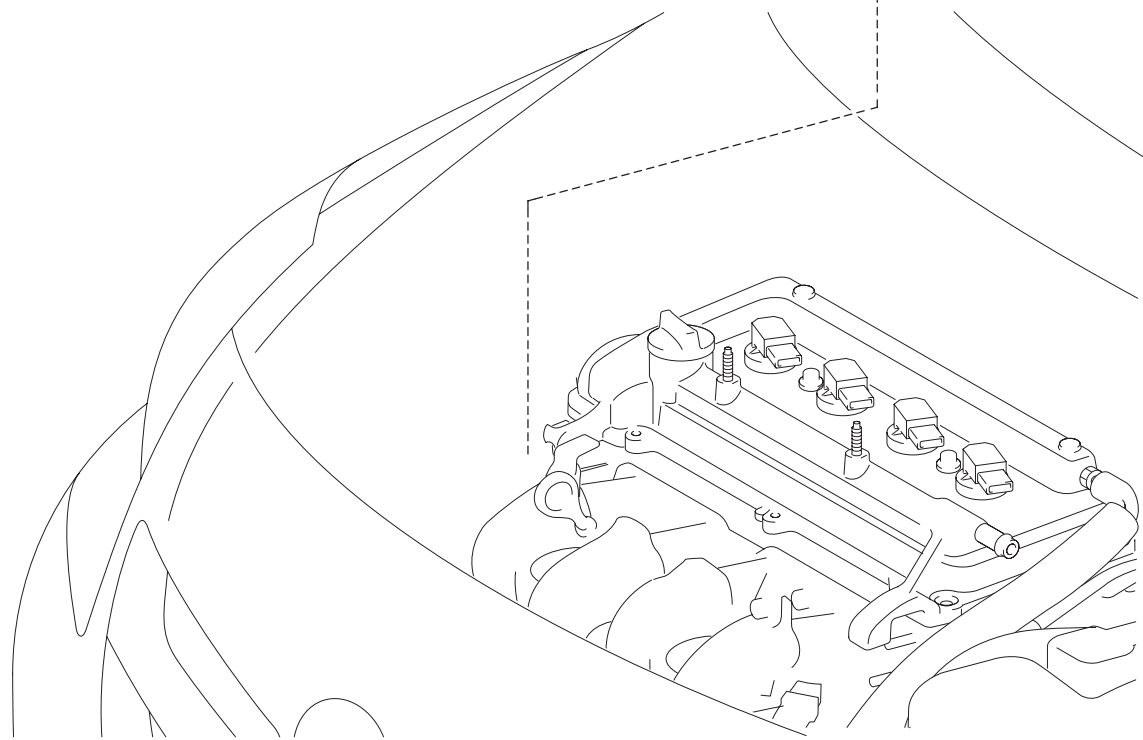

N*m (kgf*cm, ft*lbf) : Specified torque

EM

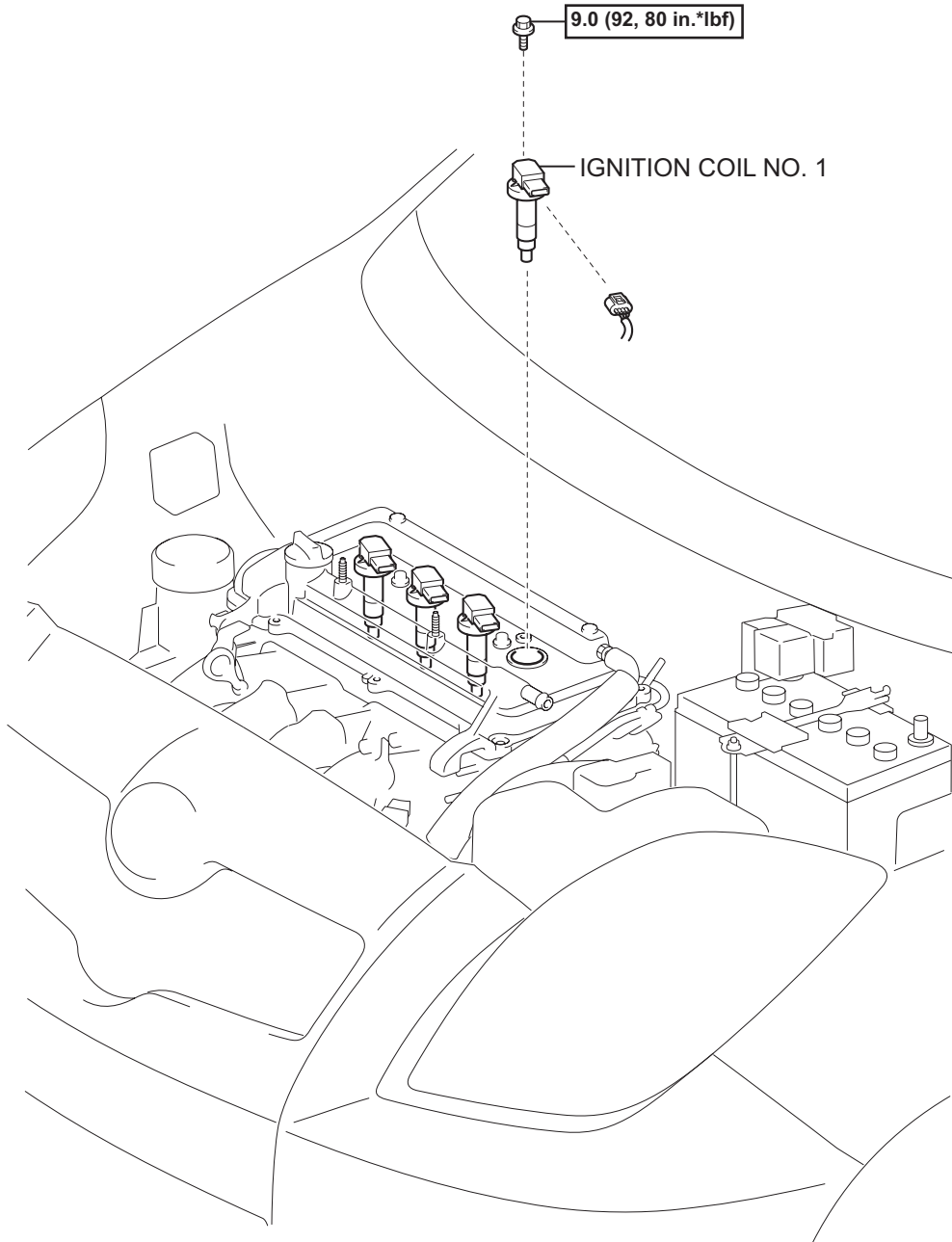

N*m (kgf*cm, ft.*lbf) : Specified torque

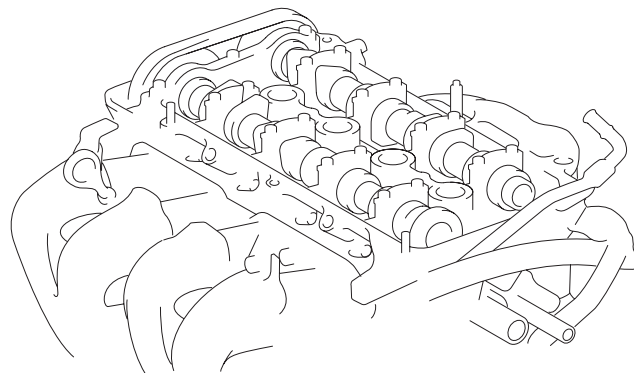
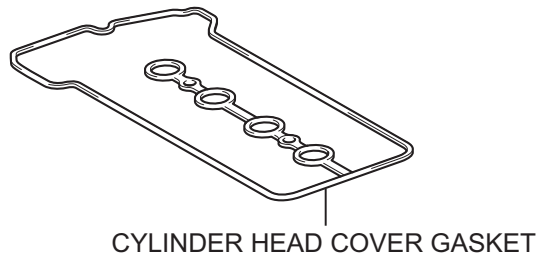
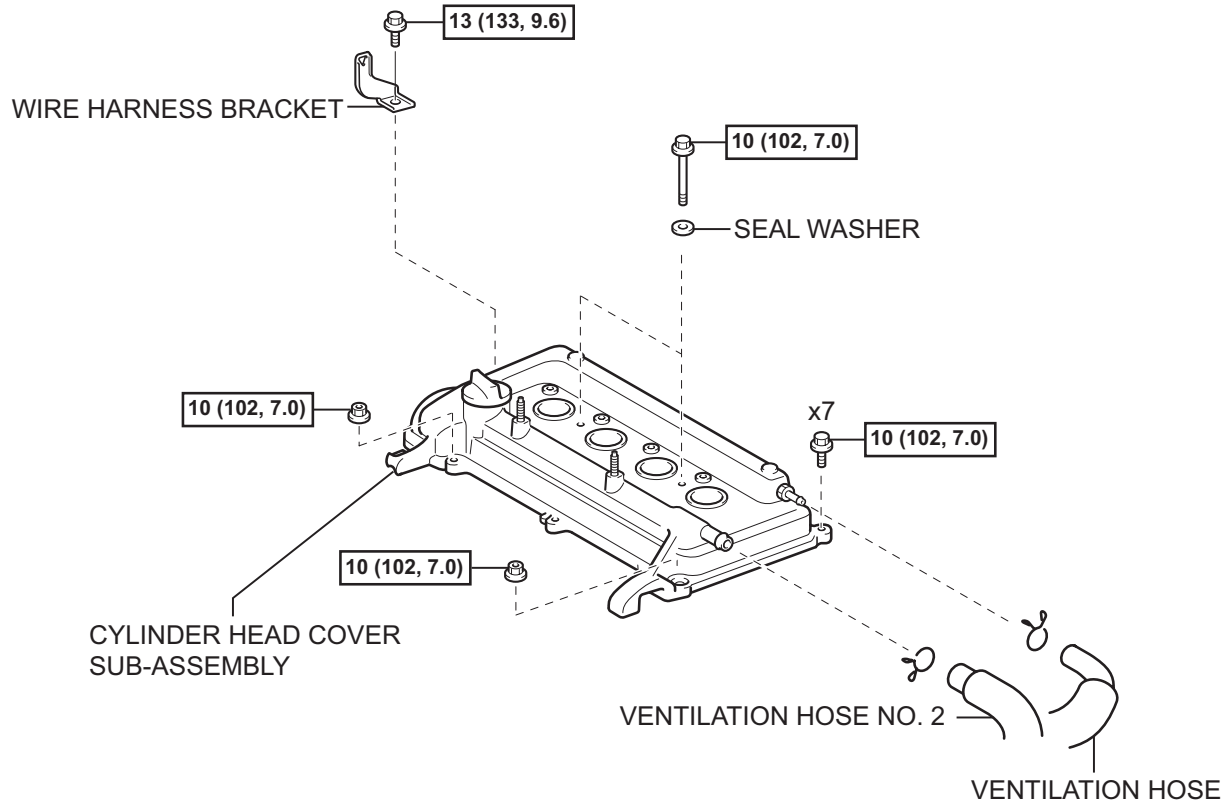

N*m (kgf*cm, ft.*lbf) : Specified torque

EM

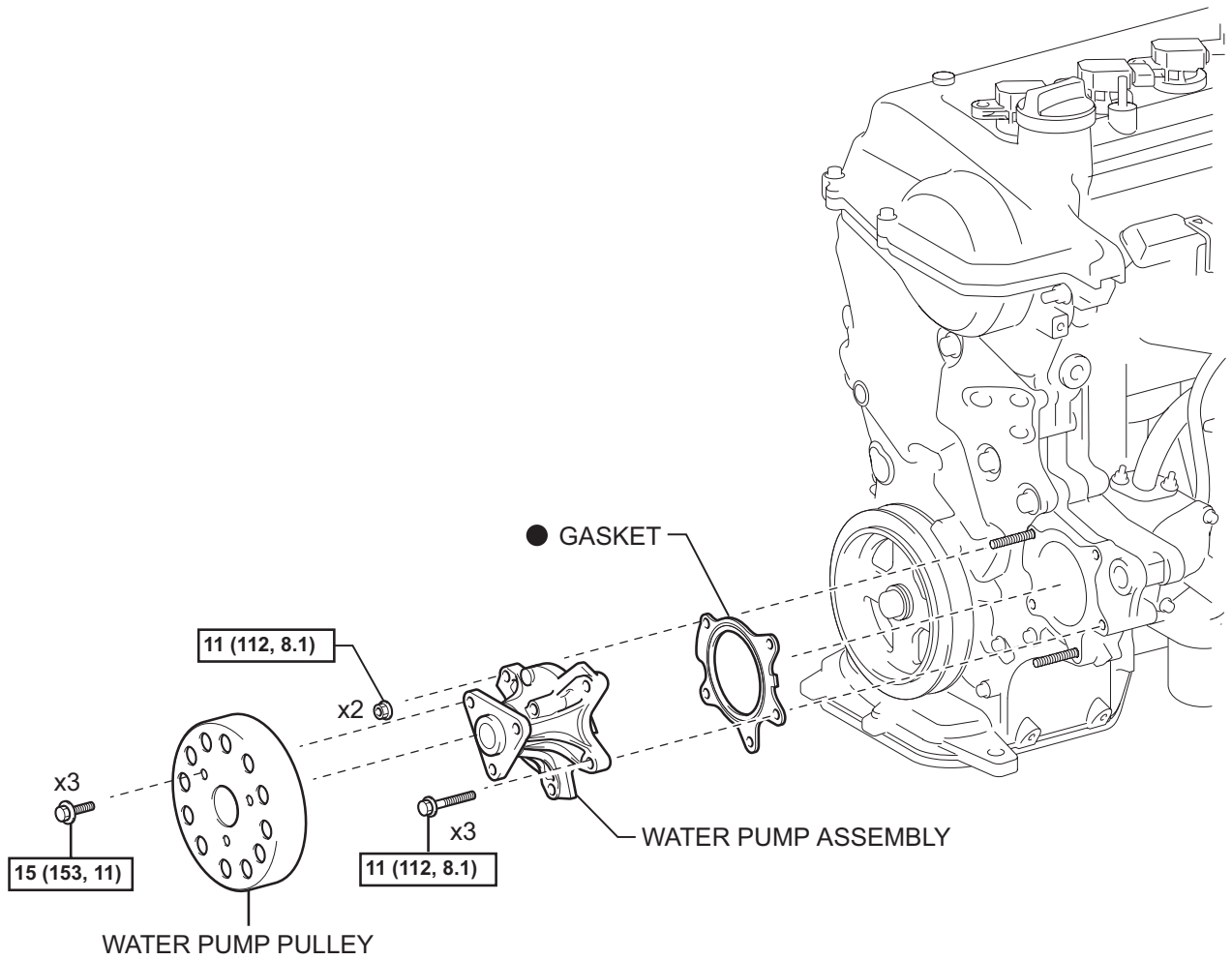

N*m (kgf*cm, ft.*lbf) : Specified torque

● Non-reusable part

T

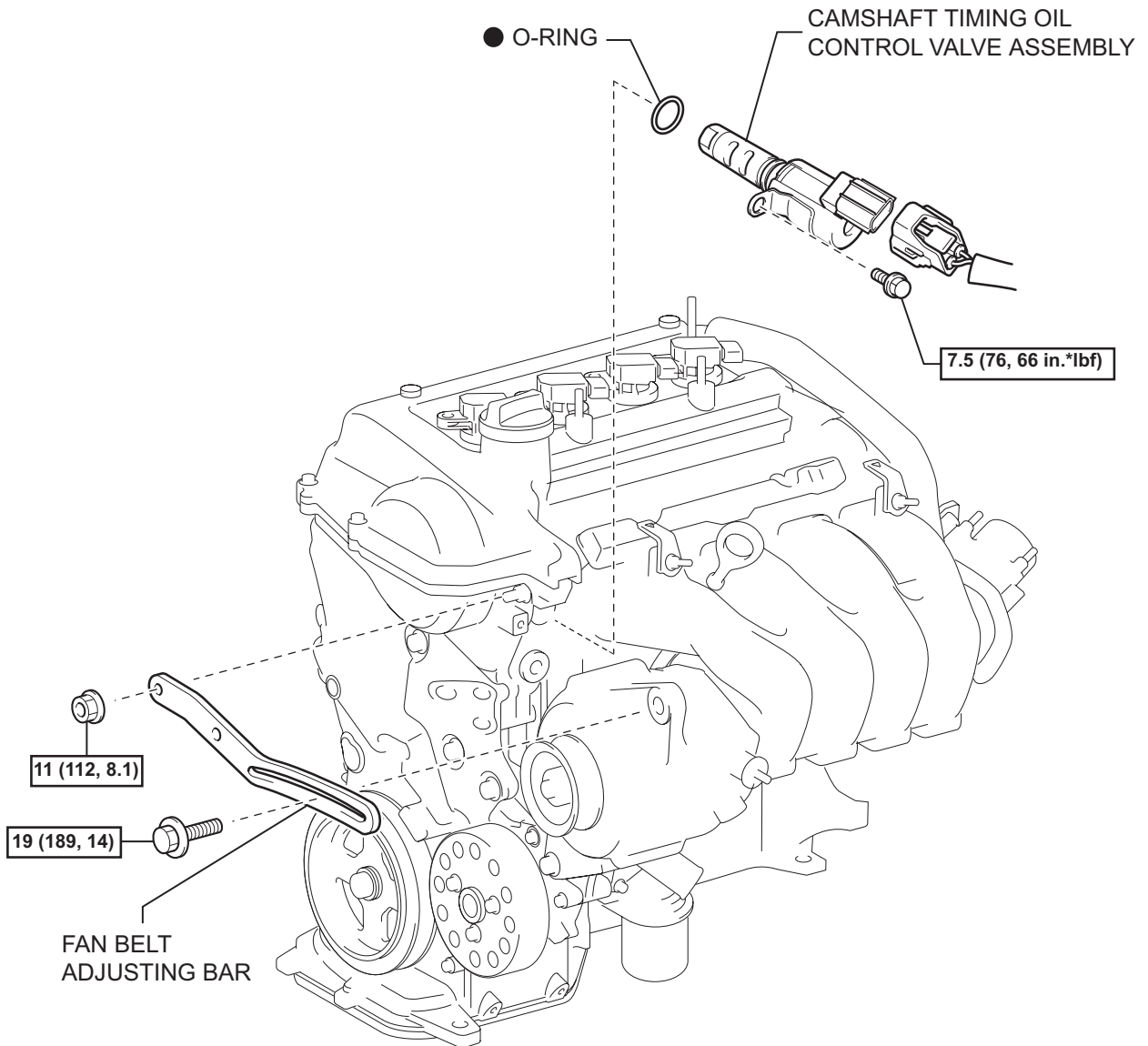

[N*m (kgf*cm, ft.*lbf)] : Specified torque

● Non-reusable part

EM

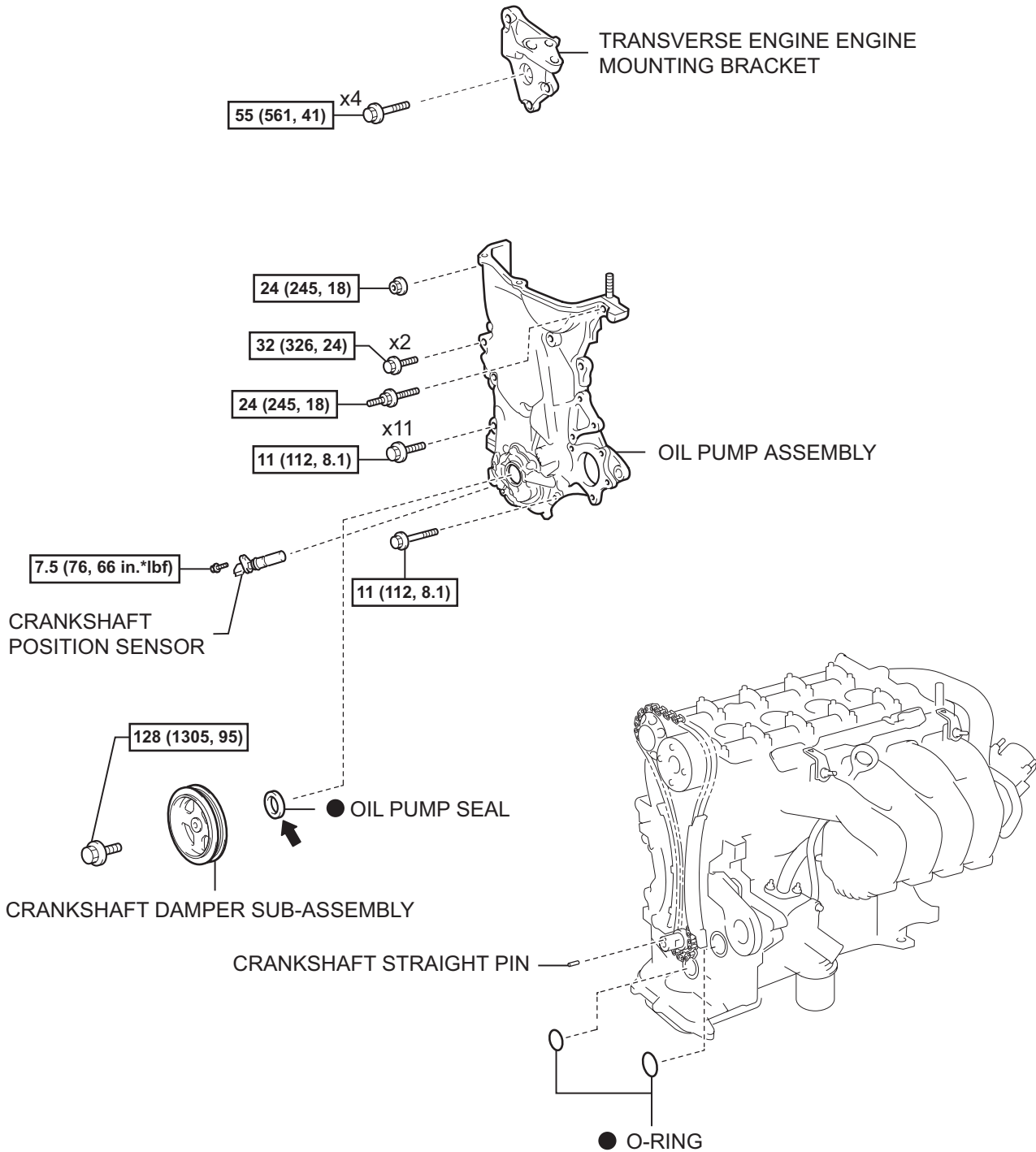

[N*m (kgf*cm, ft.*lbf)] : Specified torque

● Non-reusable part

← Apply MP grease

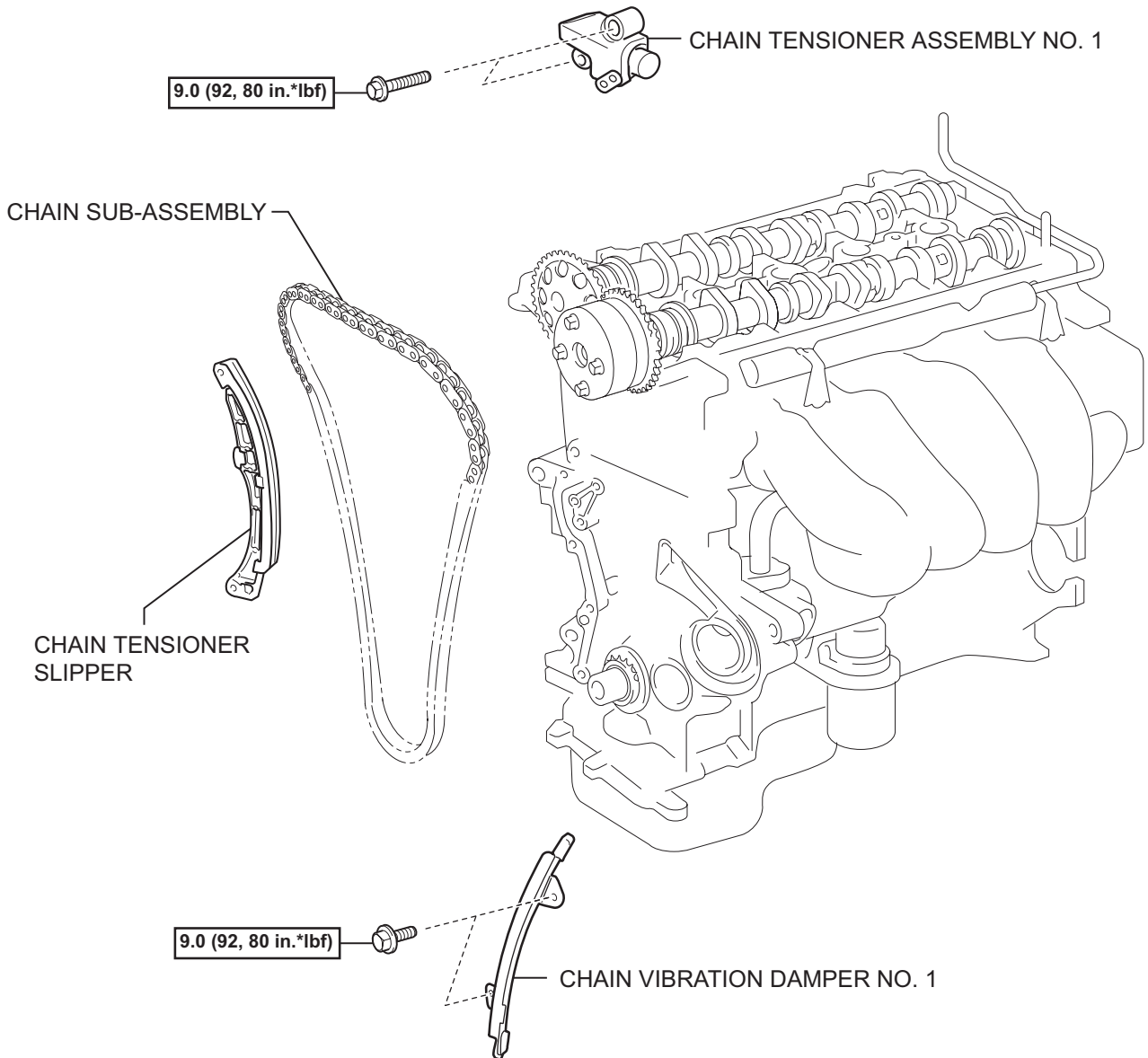

N*m (kgf*cm, ft.*lbf) : Specified torque

EM

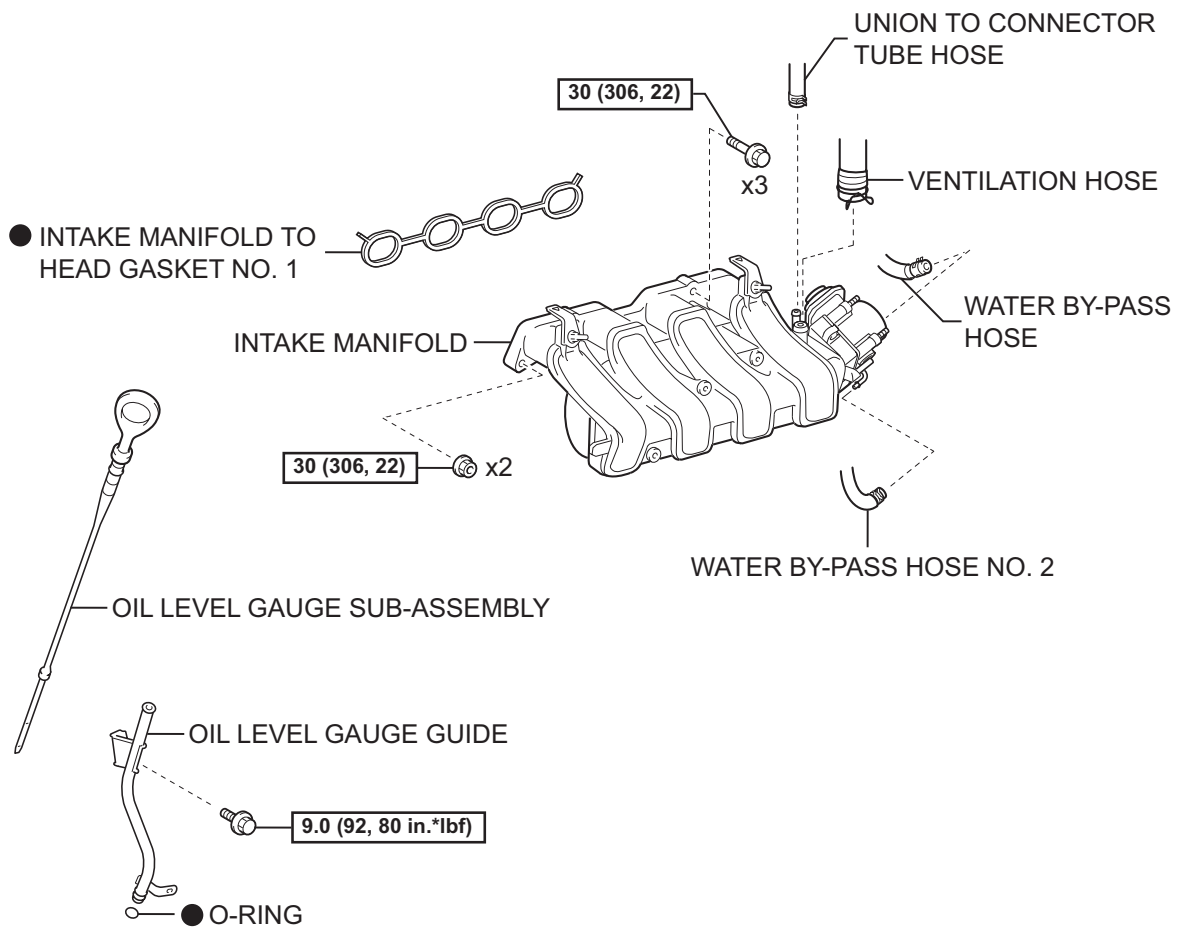
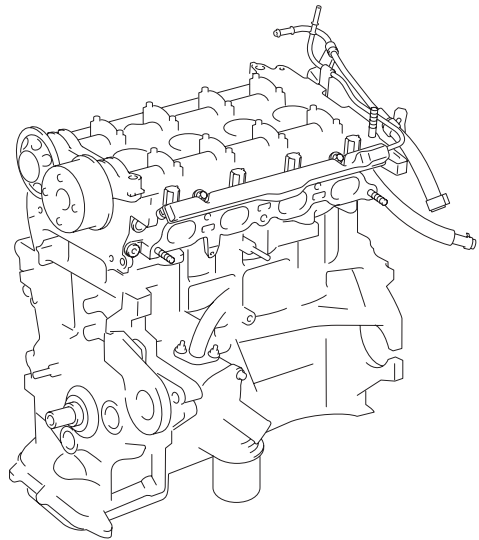

N*m (kgf*cm, ft*lbf) : Specified torque

● Non-reusable part

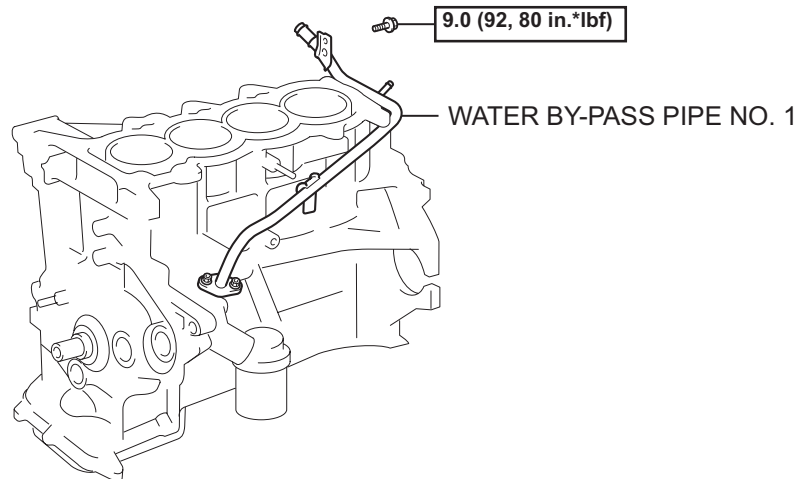
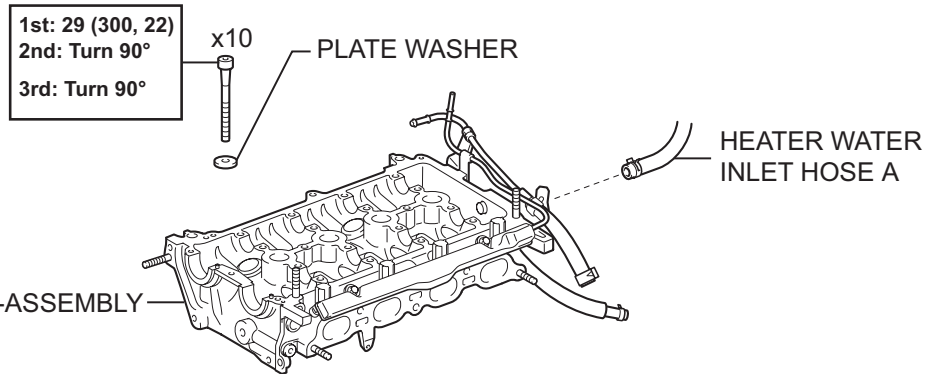
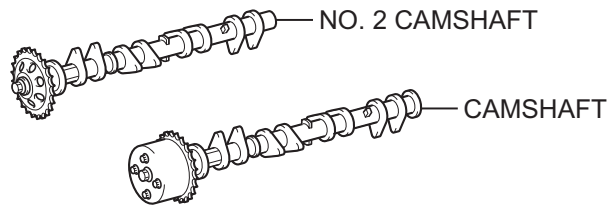
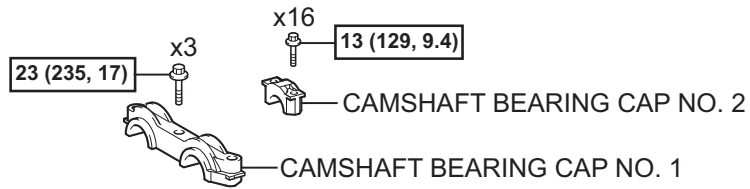

[N*m (kgf*cm, ft.*lbf)] : Specified torque

● Non-reusable part

EM

EM

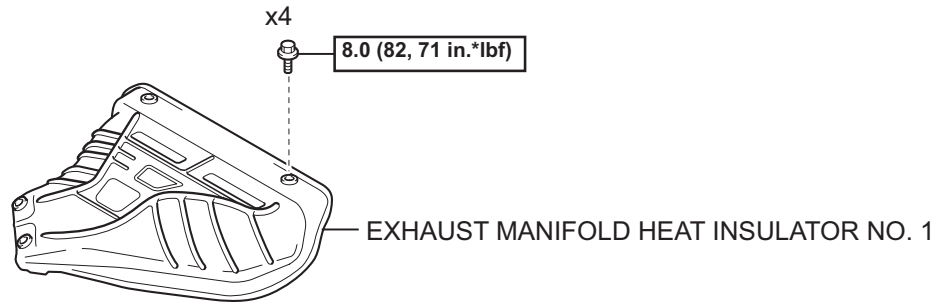

● EXHAUST MANIFOLD TO HEAD GASKET

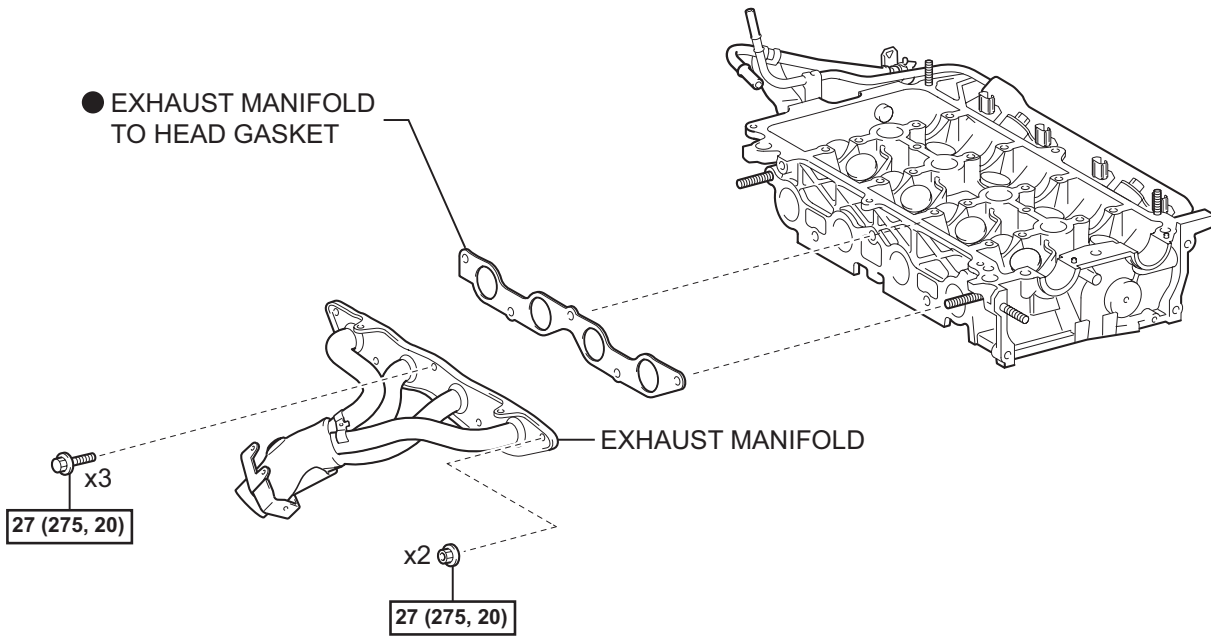

N*m (kgf*cm, ft.*lbf) : Specified torque

● Non-reusable part

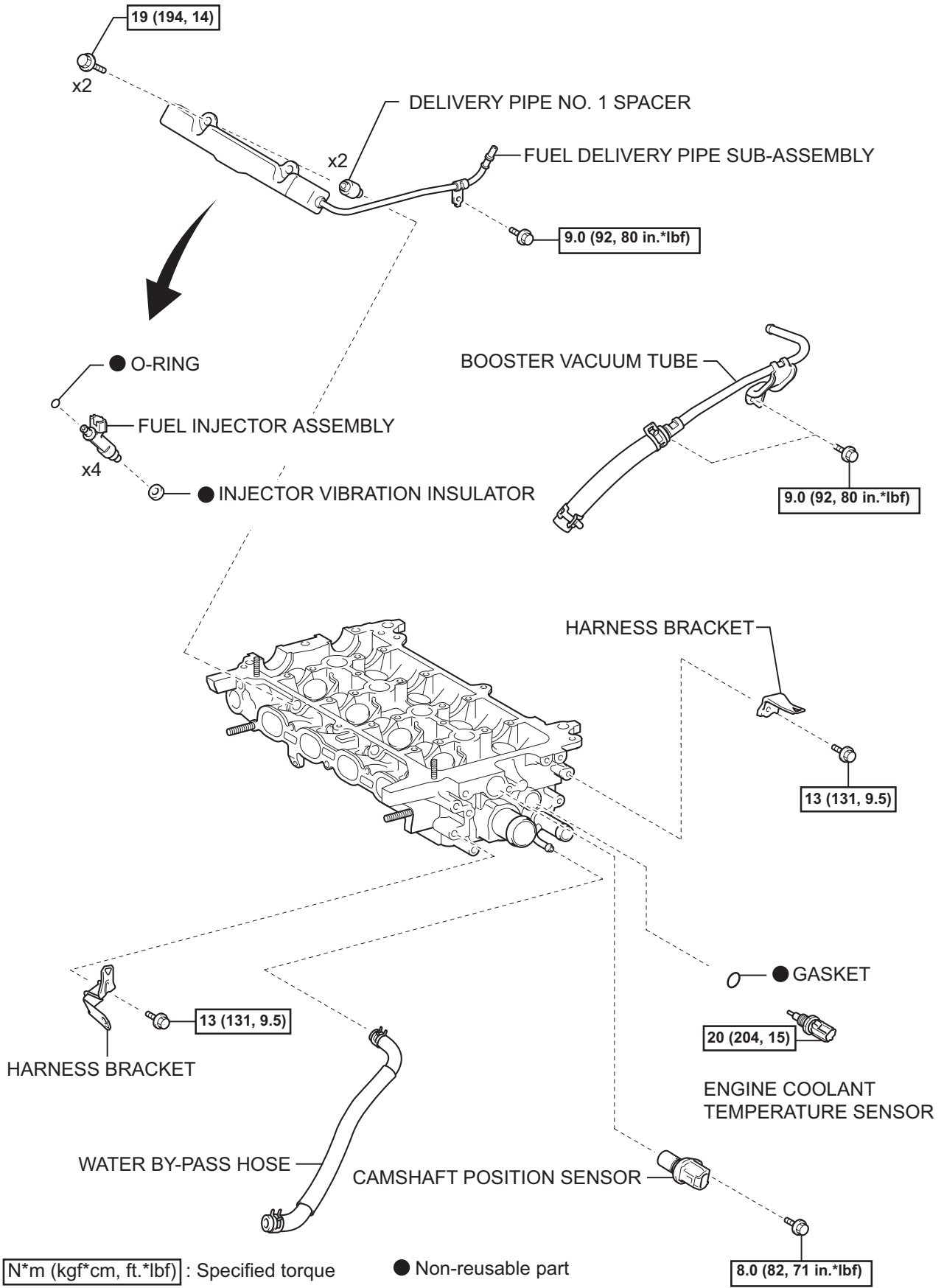

EM

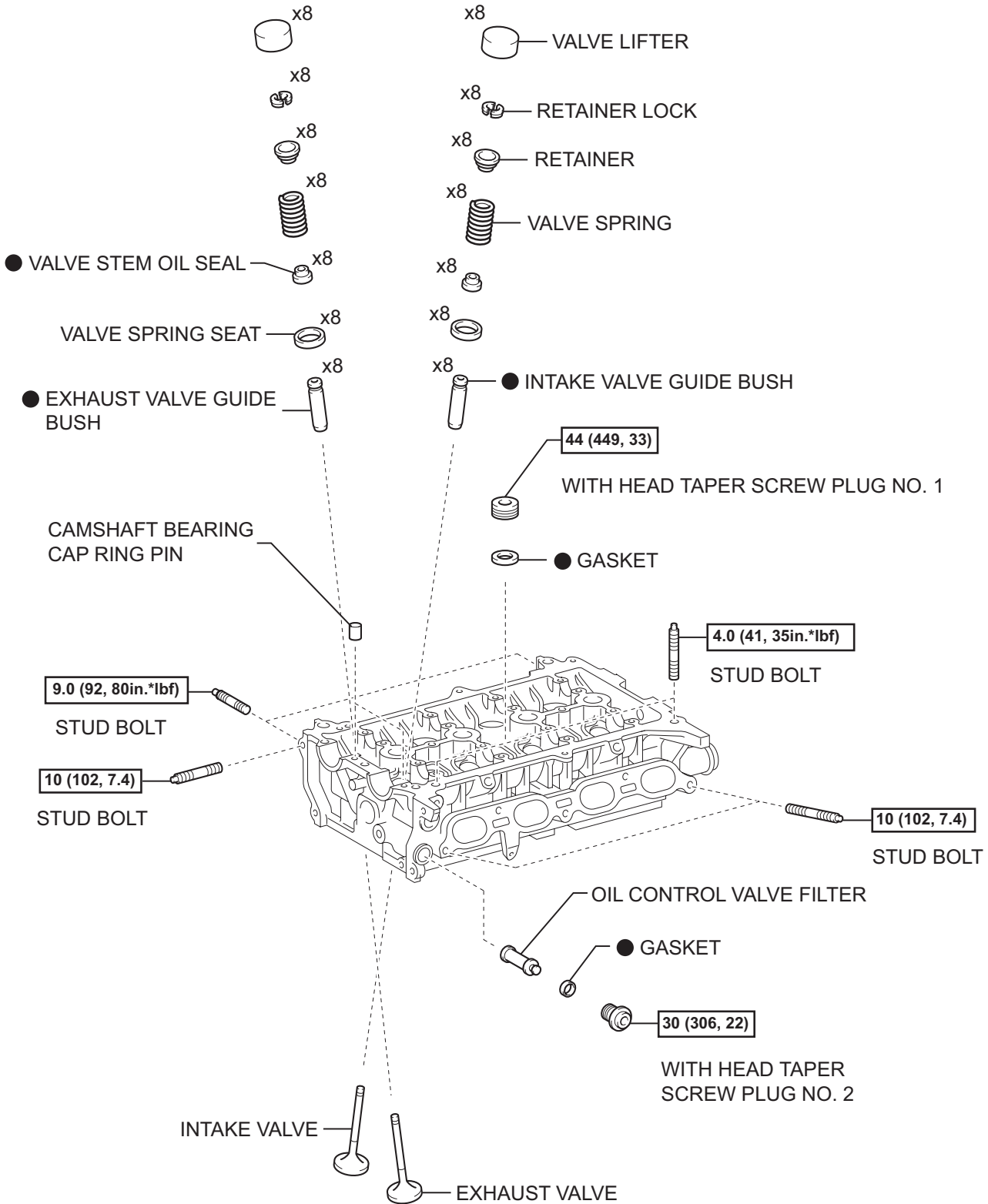

N*m (kgf*cm, ft.*lbf) : Specified torque

● Non-reusable part

T

REMOVAL

1. DISCHARGE FUEL SYSTEM PRESSURE
(See Page [FU-1](#))
2. DISCONNECT CABLE FROM NEGATIVE BATTERY TERMINAL
3. REMOVE FRONT WIPER ARM HEAD CAP (for Hatchback) (See page [WW-17](#))
4. REMOVE FRONT WIPER ARM HEAD CAP (for Sedan) (See page [WW-9](#))
5. REMOVE FRONT WIPER ARM AND BLADE ASSEMBLY LH (for Hatchback) (See page [WW-17](#))
6. REMOVE FRONT WIPER ARM AND BLADE ASSEMBLY LH (for Sedan) (See page [WW-9](#))
7. REMOVE FRONT WIPER ARM AND BLADE ASSEMBLY RH (for Hatchback) (See page [WW-17](#))
8. REMOVE FRONT WIPER ARM AND BLADE ASSEMBLY RH (for Sedan) (See page [WW-9](#))
9. REMOVE HOOD TO COWL TOP SEAL (for Hatchback) (See page [WW-18](#))
10. REMOVE COWL TOP VENTILATOR LOUVER SUB-ASSEMBLY (for Hatchback) (See page [WW-18](#))
11. REMOVE COWL TOP VENTILATOR LOUVER LH (for Hatchback) (See page [WW-18](#))
12. REMOVE COWL SIDE VENTILATOR SUB-ASSEMBLY LH (for Sedan) (See page [WW-10](#))
13. REMOVE COWL SIDE VENTILATOR SUB-ASSEMBLY RH (for Sedan) (See page [WW-10](#))
14. REMOVE COWL TOP VENTILATOR LOUVER SUB-ASSEMBLY (for Sedan) (See page [WW-10](#))
15. REMOVE FRONT WIPER MOTOR AND LINK (for Hatchback) (See page [WW-19](#))
16. REMOVE FRONT WIPER MOTOR AND LINK (for Sedan) (See page [WW-10](#))
17. REMOVE COWL TO REGISTER DUCT SUB-ASSEMBLY NO. 2 (for Hatchback) (See page [EM-122](#))
18. REMOVE FRONT AIR SHUTTER SEAL RH (for Sedan) (See page [ES-432](#))
19. REMOVE COWL TOP PANEL OUTER (for Hatchback) (See page [EM-123](#))
20. REMOVE COWL TOP PANEL OUTER (for Sedan) (See page [ES-432](#))
21. REMOVE BATTERY
22. REMOVE BATTERY TRAY
23. REMOVE FRONT WHEEL RH

24. REMOVE ENGINE UNDER COVER RH
25. DRAIN ENGINE OIL
26. DRAIN ENGINE COOLANT (See page [CO-8](#))
27. REMOVE CYLINDER HEAD COVER NO. 2 (See page [IG-9](#))
28. REMOVE AIR CLEANER CAP SUB-ASSEMBLY WITH AIR CLEANER HOSE NO. 1 (See page [ES-410](#))
29. DISCONNECT RADIATOR HOSE NO. 3
 - (a) Disconnect radiator hose No. 3.

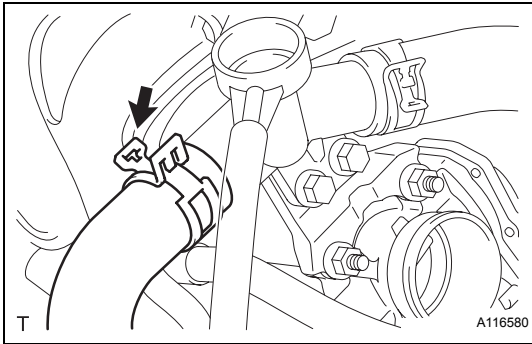

30. DISCONNECT RESERVE TANK HOSE
 - (a) Disconnect the reserve tank hose.

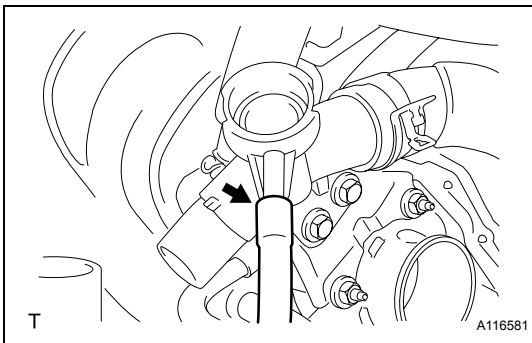

31. REMOVE WATER FILLER SUB-ASSEMBLY
 - (a) Separate radiator hose No. 1 from the cylinder head.
 - (b) Remove the 2 nuts and remove the water filler sub-assembly.

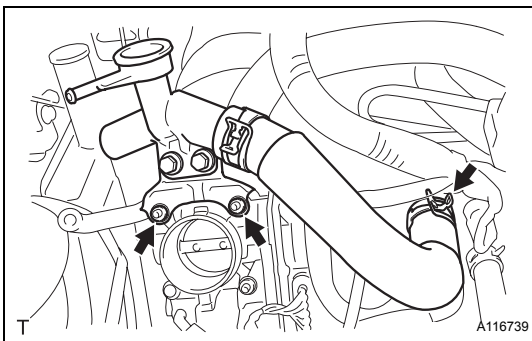

32. DISCONNECT WATER BY-PASS HOSE NO. 2
 - (a) Disconnect water by-pass hose No. 2.

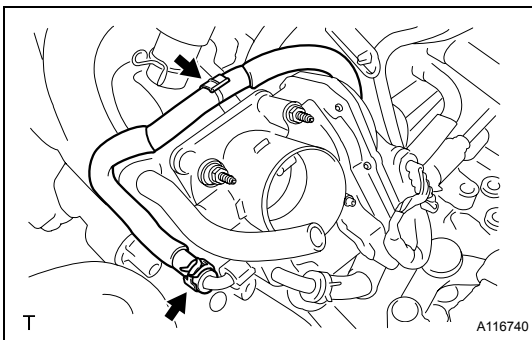

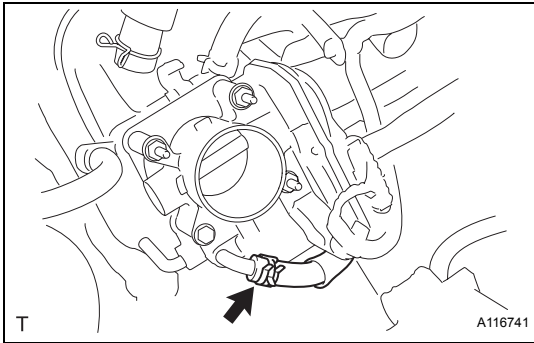
**33. DISCONNECT WATER BY-PASS HOSE**

- (a) Disconnect the water by-pass hose.

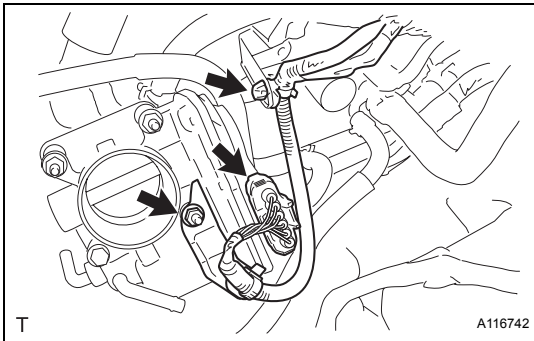
**34. DISCONNECT THROTTLE WITH MOTOR BODY CONNECTOR**

- (a) Separate the wire harness clamp.
 (b) Remove the nut and separate the throttle with motor body connector.

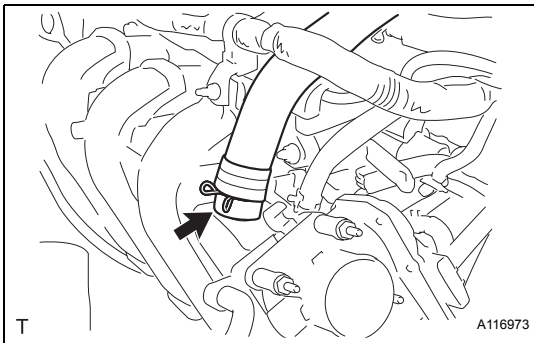
**35. DISCONNECT VENTILATION HOSE**

- (a) Disconnect the ventilation hose.

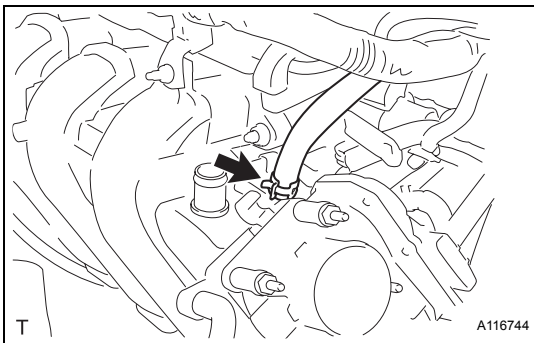
**36. DISCONNECT UNION TO CONNECTOR TUBE HOSE**

- (a) Disconnect the union to connector tube hose.

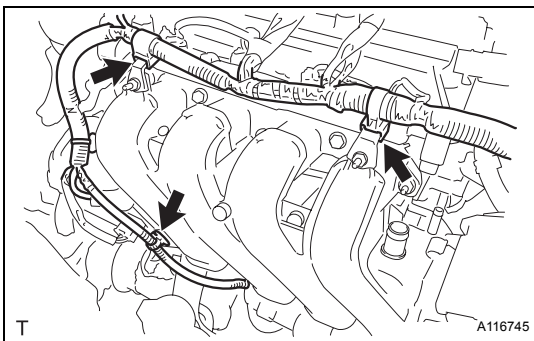
37. REMOVE OIL LEVEL GAUGE SUB-ASSEMBLY**38. REMOVE INTAKE MANIFOLD**

- (a) Separate the 3 wire harness clamps shown in the illustration.

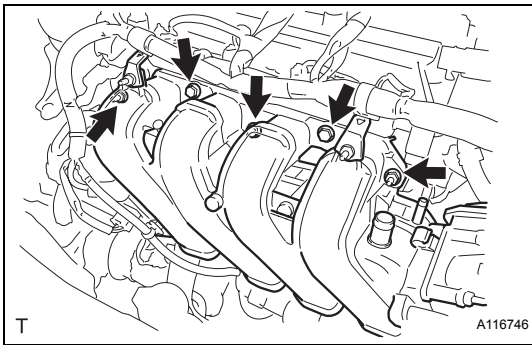

- (b) Remove the 3 bolts and 2 nuts and remove the intake manifold.

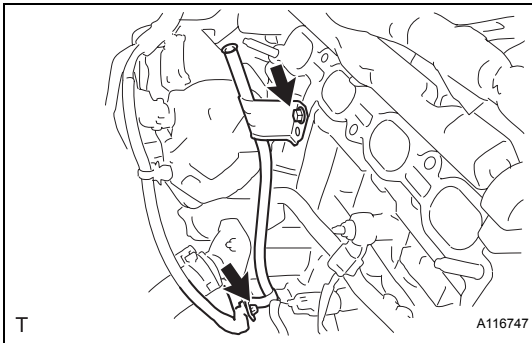

39. REMOVE OIL LEVEL GAUGE GUIDE

- (a) Remove the wire harness clamp and the bolt and remove the oil level gauge guide.

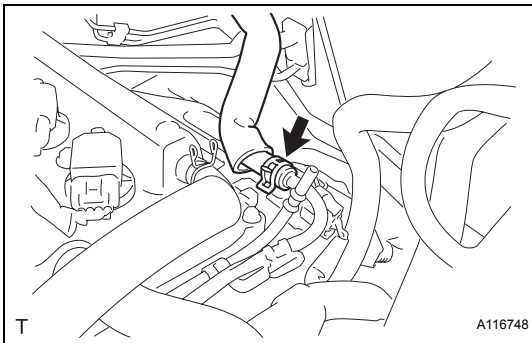

41. DISCONNECT BOOSTER VACUUM TUBE

- (a) Disconnect the booster vacuum tube.

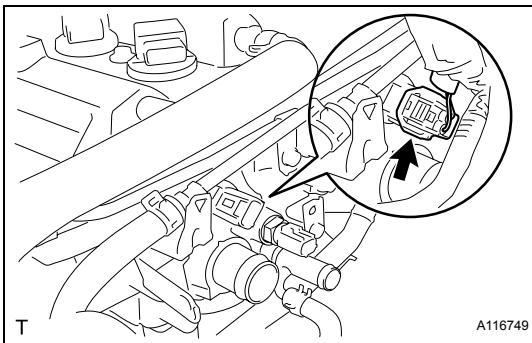

42. DISCONNECT CAMSHAFT POSITION SENSOR CONNECTOR

- (a) Disconnect the camshaft position sensor connector.

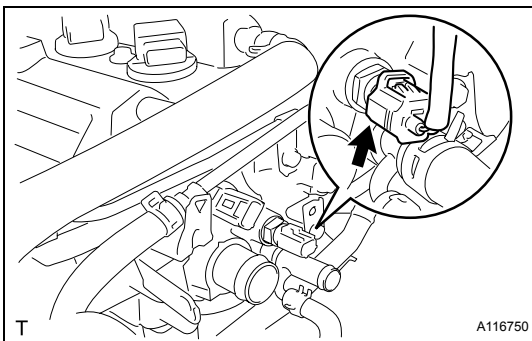

43. DISCONNECT ENGINE COOLANT TEMPERATURE SENSOR CONNECTOR

- (a) Disconnect the engine coolant temperature sensor connector.

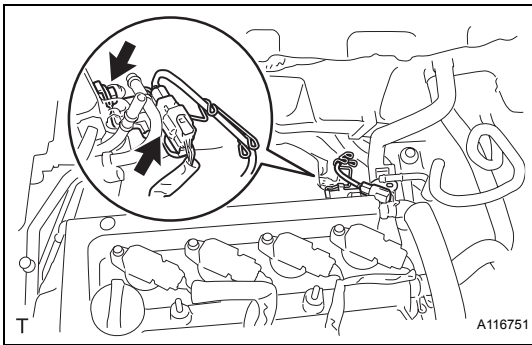

44. DISCONNECT HEATED OXYGEN SENSOR CONNECTOR

- (a) Remove the bolts and separate the sensor bracket.
- (b) Disconnect the heated oxygen sensor connector.

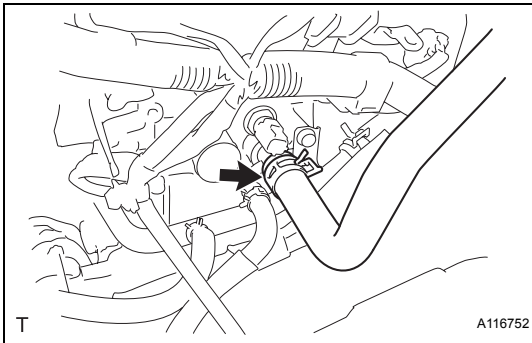

45. DISCONNECT HEATER WATER INLET HOSE A

- (a) Disconnect heater water inlet hose A.

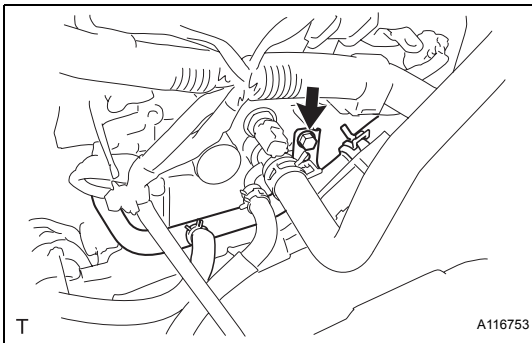

46. SEPARATE WATER BY-PASS PIPE NO. 1

- (a) Remove the bolt and separate water by-pass pipe No. 1.

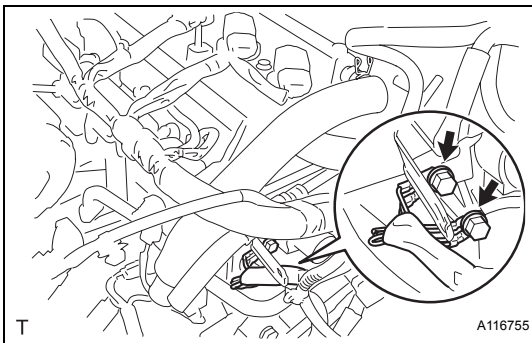

47. DISCONNECT WIRE HARNESS

- (a) Remove the 2 bolts and disconnect the wire harness.

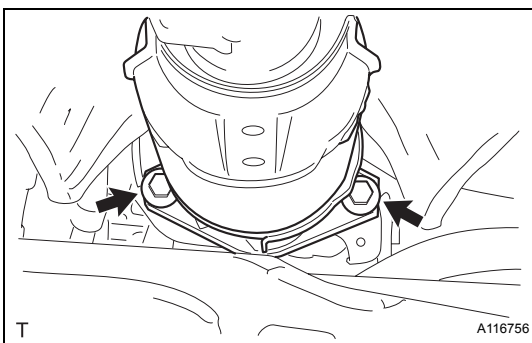

48. SEPARATE EXHAUST PIPE ASSEMBLY FRONT

- (a) Remove the 2 bolts and 2 compression springs and separate the exhaust pipe assembly front.

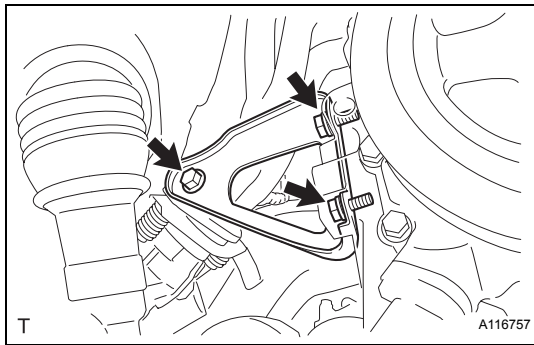

49. **REMOVE MANIFOLD SUPPORT BRACKET**
(a) Remove the 3 bolts and remove the manifold support bracket.
50. **REMOVE FAN AND GENERATOR V BELT** (See page [EM-7](#))
51. **REMOVE GENERATOR ASSEMBLY** (See page [CH-10](#))
52. **REMOVE IGNITION COIL NO. 1** (See page [IG-9](#))
53. **REMOVE VENTILATION HOSE** (See page [FU-13](#))
54. **REMOVE VENTILATION HOSE NO. 2** (See page [FU-13](#))
55. **REMOVE CYLINDER HEAD COVER SUB-ASSEMBLY** (See page [FU-13](#))
56. **REMOVE ENGINE MOUNTING INSULATOR SUB-ASSEMBLY RH** (See page [LU-17](#))
57. **REMOVE CRANKSHAFT DAMPER SUB-ASSEMBLY** (See page [LU-18](#))
58. **REMOVE CRANKSHAFT POSITION SENSOR** (See page [ES-403](#))
59. **REMOVE CAMSHAFT TIMING OIL CONTROL VALVE ASSEMBLY** (See page [ES-396](#))
60. **REMOVE WATER PUMP PULLEY** (See page [CO-15](#))
61. **REMOVE WATER PUMP ASSEMBLY** (See page [CO-15](#))
62. **REMOVE TRANSVERSE ENGINE ENGINE MOUNTING BRACKET** (See page [LU-17](#))
63. **REMOVE OIL PUMP ASSEMBLY** (See page [LU-19](#))
64. **REMOVE OIL PUMP SEAL** (See page [LU-21](#))
65. **REMOVE CHAIN TENSIONER ASSEMBLY NO. 1** (See page [EM-33](#))
66. **REMOVE CHAIN TENSIONER SLIPPER** (See page [EM-35](#))
67. **REMOVE CHAIN VIBRATION DAMPER NO. 1** (See page [EM-35](#))
68. **REMOVE CHAIN SUB-ASSEMBLY**
69. **REMOVE CAMSHAFT**
NOTICE:
When rotating the camshaft with the timing chain removed, rotate the crankshaft counterclockwise 40° from the TDC first.

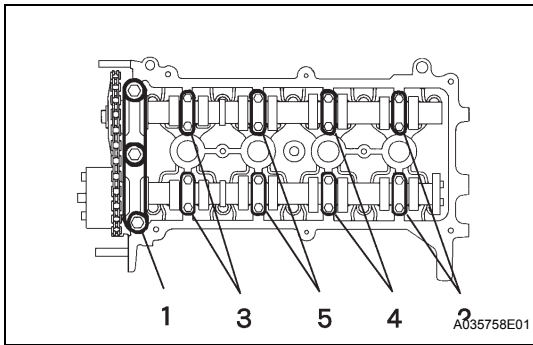

- (a) Using several steps, uniformly loosen and remove the 19 bearing cap bolts in the sequence shown in the illustration, and then remove camshaft bearing cap No. 1 and camshaft bearing cap No. 2.

NOTICE:

Loosen each bolt uniformly while keeping the camshaft level.

- (b) Remove the camshaft and camshaft No. 2.

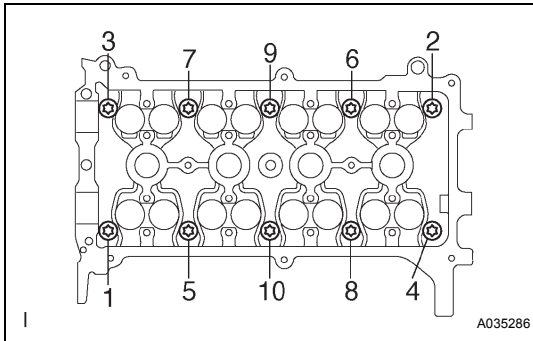
**70. REMOVE CYLINDER HEAD SUB-ASSEMBLY**

- (a) Using several steps, uniformly loosen and remove the 10 cylinder head bolts with an 8 mm bi-hexagon wrench in the sequence shown in the illustration. Remove the 10 plate washers.

NOTICE:

- Do not drop the washers into the cylinder head.
- Head warpage or cracking could result from removing the bolts in the wrong order.

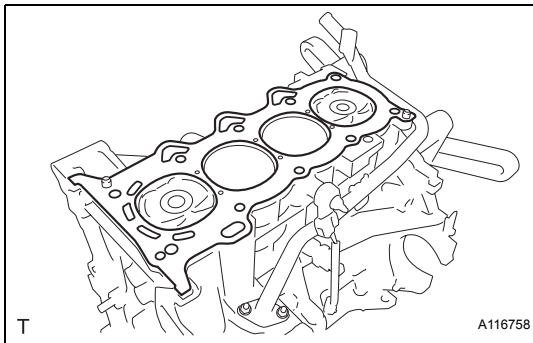
**71. REMOVE CYLINDER HEAD GASKET**

- (a) Remove the cylinder head gasket.

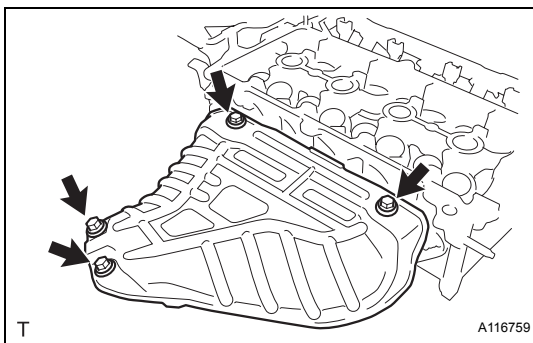
**72. REMOVE EXHAUST MANIFOLD HEAT INSULATOR NO. 1**

- (a) Remove the 4 bolts and remove exhaust manifold heat insulator No. 1.

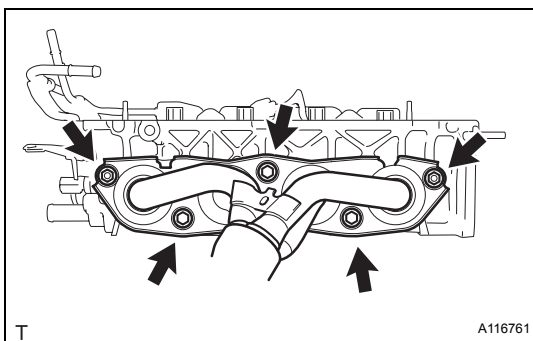
**73. REMOVE EXHAUST MANIFOLD**

- (a) Remove the 3 bolts and 2 nuts and remove the exhaust manifold.

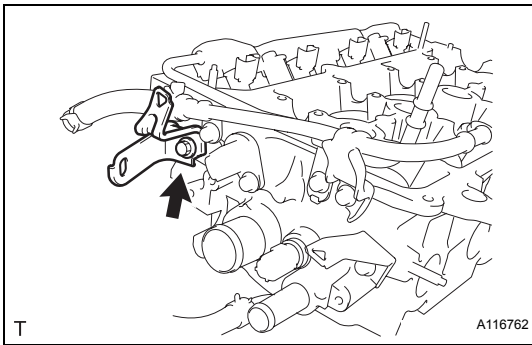
**74. REMOVE HARNESS BRACKET**

- (a) Remove the bolt and remove the harness bracket.

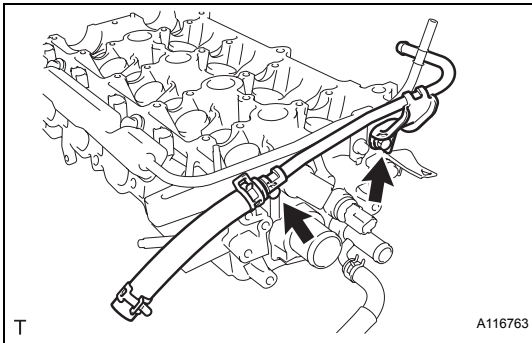
**75. REMOVE BOOSTER VACUUM TUBE**

- (a) Remove the 2 bolts and remove the booster vacuum tube.

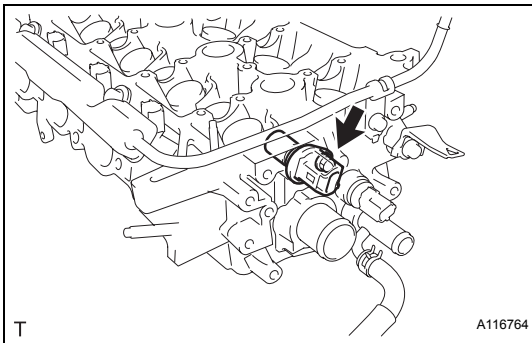
**76. REMOVE CAMSHAFT POSITION SENSOR**

- (a) Remove the bolt and remove the camshaft position sensor.

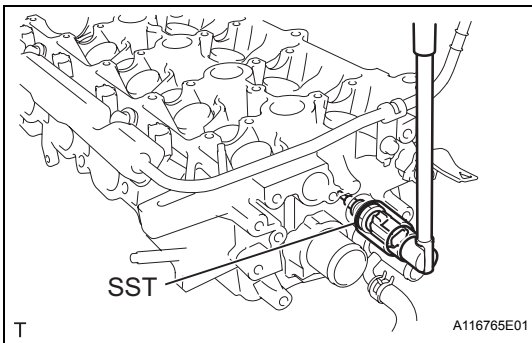
**77. REMOVE ENGINE COOLANT TEMPERATURE SENSOR**

- (a) Using SST, remove the engine coolant temperature sensor connector.

SST 09817-33190

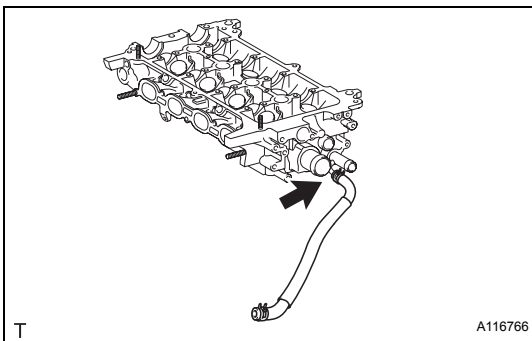
**78. REMOVE WATER BY-PASS HOSE**

- (a) Remove the water by-pass hose.

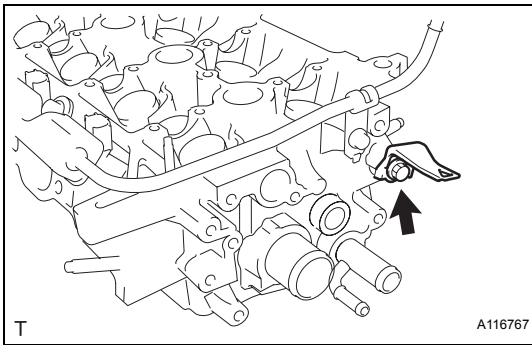
**79. REMOVE HARNESS BRACKET**

- (a) Remove the bolt and remove the harness bracket.

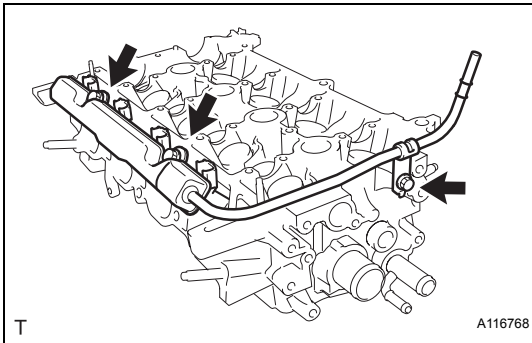
**80. REMOVE FUEL DELIVERY PIPE SUB-ASSEMBLY**

- (a) Remove the 3 bolts and remove the fuel delivery pipe sub-assembly with 4 fuel injectors.

NOTICE:

Do not drop the fuel injectors when removing the fuel delivery pipe sub-assembly.

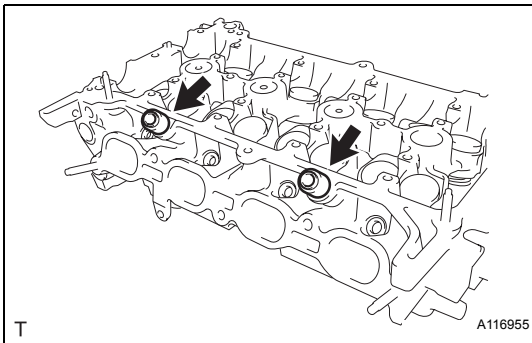
81. REMOVE FUEL INJECTOR ASSEMBLY (See page FU-16)**82. REMOVE DELIVERY PIPE NO. 1 SPACER**

- (a) Remove the 2 delivery pipe No. 1 spacers.

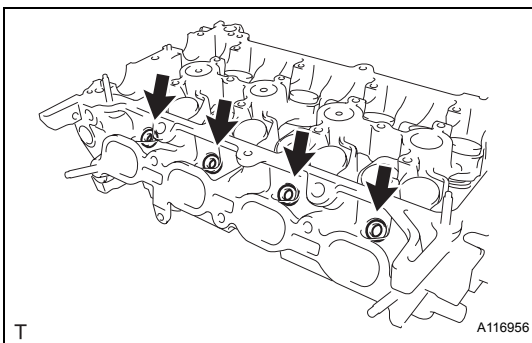
**83. REMOVE INJECTOR VIBRATION INSULATOR**

- (a) Remove the 4 injector vibration insulators.

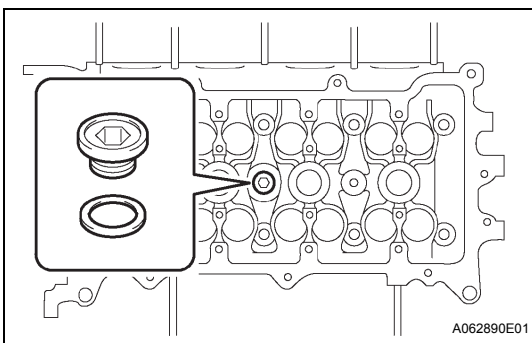
**DISASSEMBLY****1. REMOVE WITH HEAD TAPER SCREW PLUG NO. 1**

- (a) Using a 10 mm socket hexagon wrench, remove the taper screw plug and the gasket.

2. REMOVE VALVE LIFTER**HINT:**

Keep the valve lifters in the correct order so that they can be returned to their original locations when reassembled.

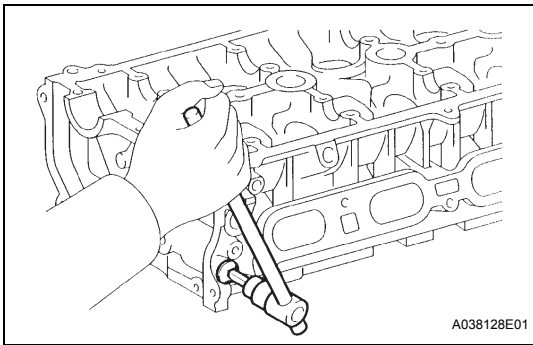

- 3. REMOVE WITH HEAD TAPER SCREW PLUG NO. 2**
 (a) Using an 8 mm hexagon wrench, remove the taper screw plug.

4. REMOVE OIL CONTROL VALVE FILTER

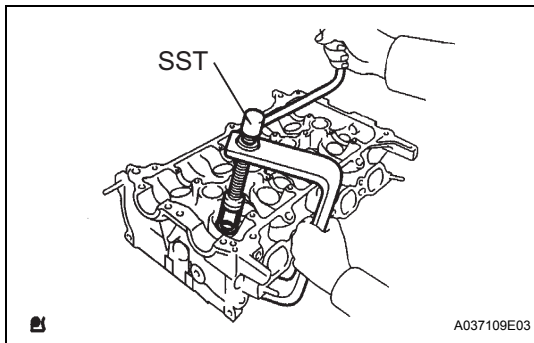

5. REMOVE INTAKE VALVE

- (a) Using SST, compress the valve spring and remove the 2 retainer locks, retainer and valve spring.

SST 09202-70020 (09202-00010)

HINT:

Keep the valves, valve springs, spring seats and spring retainers in the correct order so that they can be returned to their original locations when reassembled.

6. REMOVE EXHAUST VALVE

- (a) Using SST, compress the valve spring and remove the 2 retainer locks, retainer and valve spring.

SST 09202-70020 (09202-00010)

HINT:

Keep the valves, valve springs, spring seats and spring retainers in the correct order so that they can be returned to their original locations when reassembled.

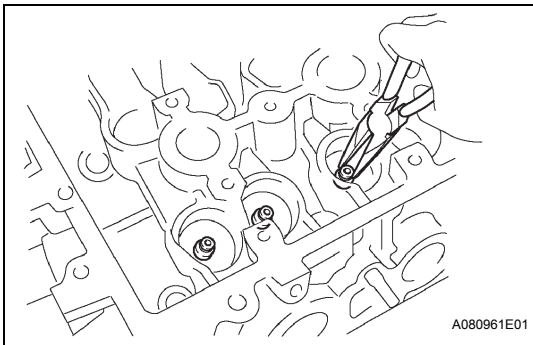

7. REMOVE VALVE STEM OIL SEAL

- (a) Using needle-nose pliers, remove the oil seal.

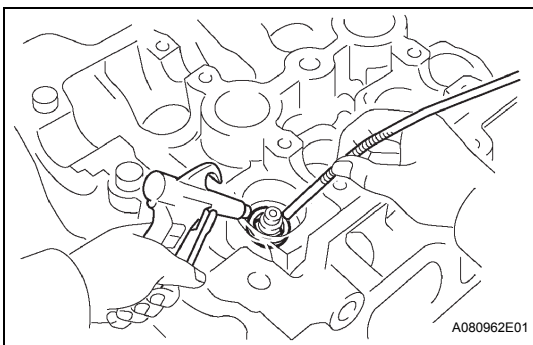

8. REMOVE VALVE SPRING SEAT

- (a) Using compressed air and a magnetic finger, remove the valve spring seats.

9. REMOVE STUD BOLT

- (a) Using "Torx" socket wrenches E5 and E7, remove the 7 stud bolts.

10. REMOVE CAMSHAFT BEARING CAP SETTING RING PIN

INSPECTION

1. INSPECT CYLINDER HEAD FOR WARPAGE

- (a) Using a precision straightedge and feeler gauge, measure the warpage of the surface that is in contact with the cylinder block and the manifolds.

Maximum warpage

Surface	Specified Condition
Cylinder block side	0.05 mm (0.0020 in.)
Intake manifold side	0.10 mm (0.0039 in.)
Exhaust manifold side	0.10 mm (0.0039 in.)

If the warpage is greater than the maximum, replace the cylinder head.

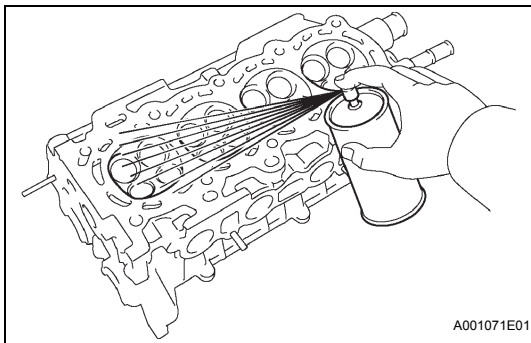
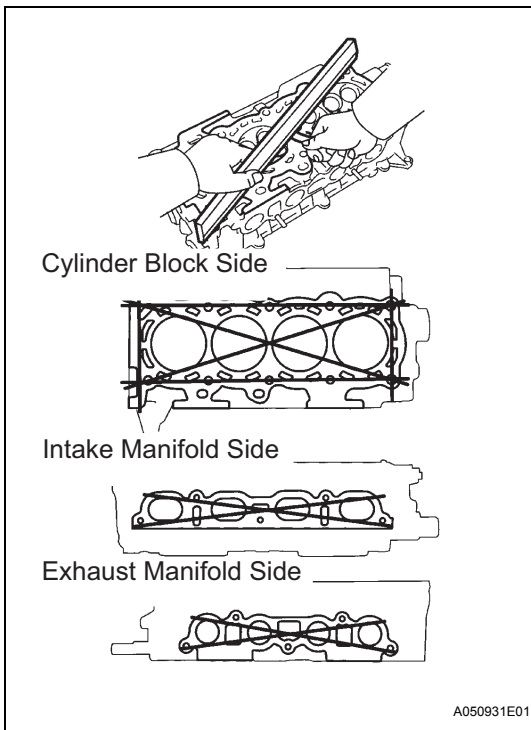

2. INSPECT CYLINDER HEAD FOR CRACKS

- (a) Using a dye penetrant, check the combustion chamber, intake ports, exhaust ports and cylinder block surface for cracks.

If cracked, replace the cylinder head.

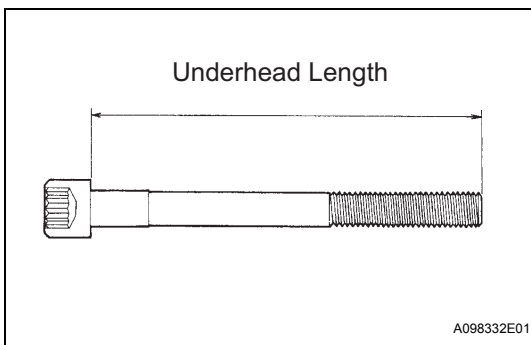

3. INSPECT CYLINDER HEAD SET BOLT

- (a) Using vernier calipers, measure the length of the head bolts from the seat to the end.

Standard length:

142.8 to 144.2 mm (5.622 to 5.677 in.)

Maximum length:

147.1 mm (5.791 in.)

If the length is greater than the maximum, replace the bolt.

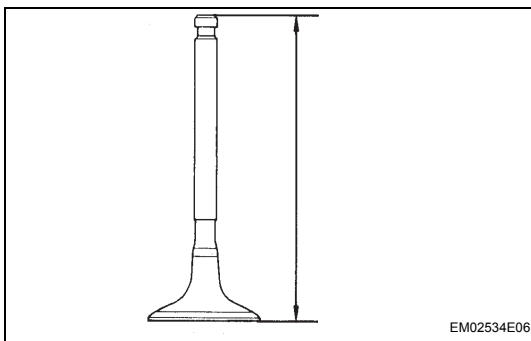

4. INSPECT INTAKE VALVE

- (a) Check the overall valve length.

Standard overall length:

89.25 mm (3.5138 in.)

Minimum overall length:

88.75 mm (3.4941 in.)

If the overall length is less than the minimum, replace the valve.

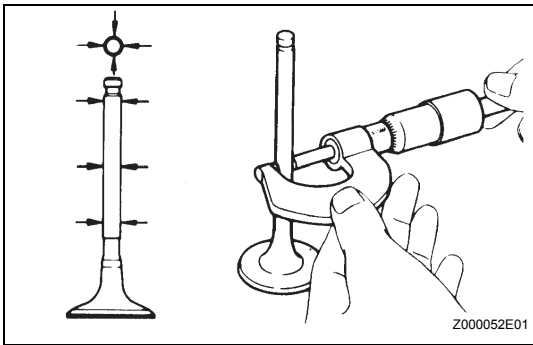

- (b) Using a micrometer, measure the diameter of the valve stem.

Standard valve stem diameter:

4.970 to 4.985 mm (0.1957 to 0.1963 in.)

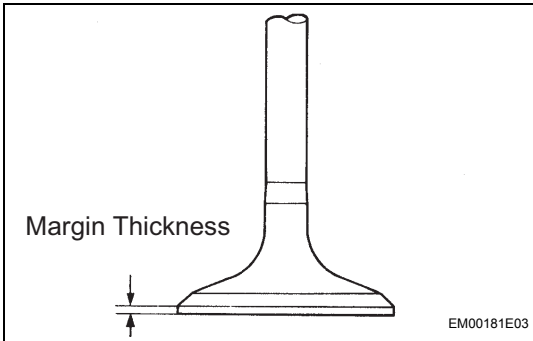

- (c) Check the valve head margin thickness.

Standard margin thickness:

1.0 mm (0.039 in.)

Minimum margin thickness:

0.5 mm (0.020 in.)

If the margin thickness is less than the minimum, replace the valve.

5. INSPECT EXHAUST VALVE

- (a) Check the overall valve length.

Standard overall length:

87.90 mm (3.4606 in.)

Minimum overall length:

87.40 mm (3.4409 in.)

If the overall length is less than the minimum, replace the valve.

- (b) Using a micrometer, measure the diameter of the valve stem.

Standard valve stem diameter:

4.965 to 4.980 mm (0.1955 to 0.1961 in.)

- (c) Check the valve head margin thickness.

Standard margin thickness:

1.15 mm (0.045 in.)

Minimum margin thickness:

0.5 mm (0.020 in.)

If the margin thickness is less than the minimum, replace the valve.

6. INSPECT VALVE SPRING

- (a) Using vernier calipers, measure the free length of the valve spring.

Standard free length:

45.05 to 45.15 mm (1.774 to 1.778 in.)

If the free length is not as specified, replace the spring.

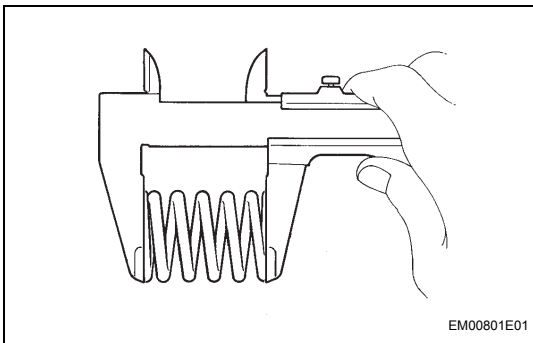

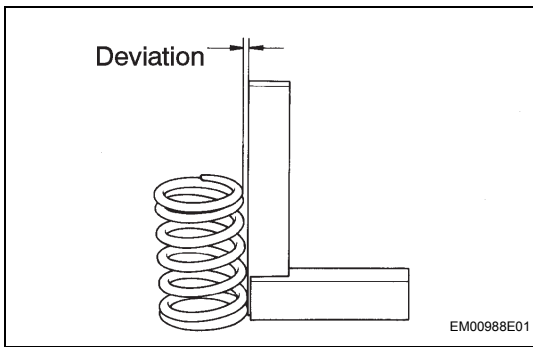

- (b) Using a steel square, measure the deviation of the valve spring.

Maximum deviation:

1.6 mm (0.063 in.)

Maximum angle (reference):

2°

If the deviation is greater than the maximum, replace the spring.

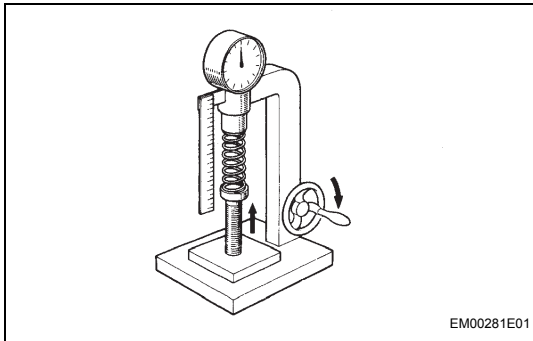

- (c) Using a spring tester, measure the tension of the valve spring at the specified installed length.

Standard installed tension:

**149 to 165 N (15.2 to 16.8 kgf, 33.5 to 37.1 lbf)
at 32.5 mm (1.280 in.)**

Maximum working tension:

**286 to 316 N (29.1 to 32.2 kgf, 64.2 to 71.0 lbf)
at 23.9 mm (0.941 in.)**

If the installed tension is not as specified, replace the valve spring.

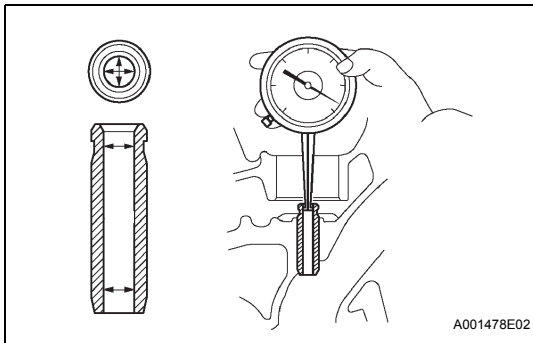

7. INSPECT VALVE GUIDE BUSH OIL CLEARANCE

- (a) Using a caliper gauge, measure the inside diameter of the guide bush.

Bush inside diameter:

5.010 to 5.030 mm (0.1972 to 0.1980 in.)

- (b) Subtract the valve stem diameter measurement from the guide bush inside diameter measurement to calculate the oil clearance.

Standard oil clearance

Guide Bush	Specified Condition
Intake	0.025 to 0.060 mm (0.0010 to 0.0024 in.)
Exhaust	0.030 to 0.065 mm (0.0012 to 0.0026 in.)

Maximum oil clearance

Guide Bush	Specified Condition
Intake	0.08 mm (0.0032 in.)
Exhaust	0.10 mm (0.0039 in.)

If the clearance is greater than the maximum, replace the valve and guide bush (see page [EM-92](#)).

8. INSPECT INTAKE VALVE SEAT

- (a) Apply a light coat of prussian blue to the valve face.
 (b) Lightly press the valve against the seat.

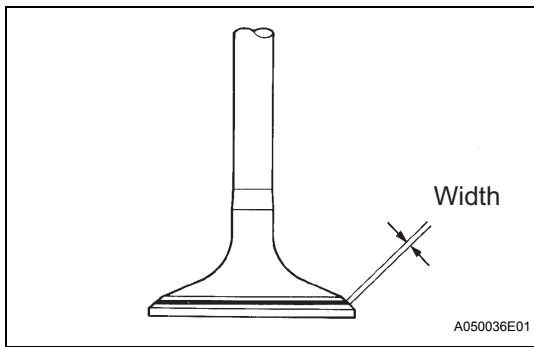

- (c) Check the valve face and seat in accordance with the following procedure.
- (1) If blue appears 360° around the face, the valve is concentric. If not, replace the valve.
 - (2) If blue appears 360° around the valve seat, the guide and face are concentric. If not, resurface the seat.
 - (3) Check that the seat contact is in the middle of the valve face with the width between 1.0 to 1.4 mm (0.039 to 0.055 in.).

9. INSPECT VALVE LIFTER

- (a) Using a micrometer, measure the lifter diameter.

Standard lifter diameter:

30.966 to 30.976 mm (1.2191 to 1.2195 in.)

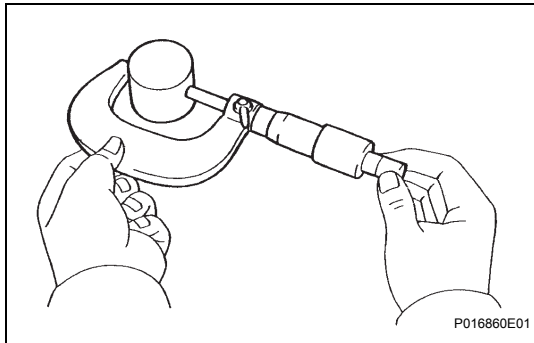

10. INSPECT VALVE LIFTER OIL CLEARANCE

- (a) Using a caliper gauge, measure the lifter bore diameter of the cylinder head.

Standard lifter bore diameter:

31.000 to 31.025 mm (1.2205 to 1.2215 in.)

- (b) Subtract the lifter diameter measurement from the lifter bore diameter measurement to calculate the oil clearance.

Standard oil clearance:

0.024 to 0.059 mm (0.0009 to 0.0023 in.)

Maximum oil clearance:

0.1 mm (0.0039 in.)

If the oil clearance is greater than the maximum, replace the lifter. If necessary, replace the cylinder head.

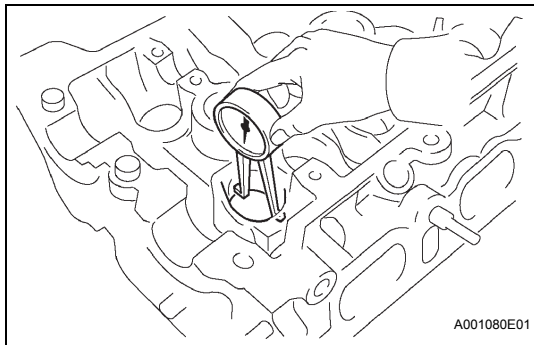

11. INSPECT CAMSHAFT

- (a) Inspect the camshaft for runout.

- (1) Place the camshaft on V-blocks.

- (2) Using a dial indicator, measure the circle runout at the center journal.

Maximum circle runout:

0.03 mm (0.0012 in.)

If the circle runout is greater than the maximum, replace the camshaft.

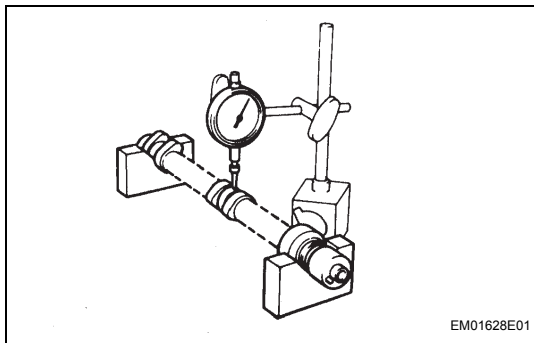

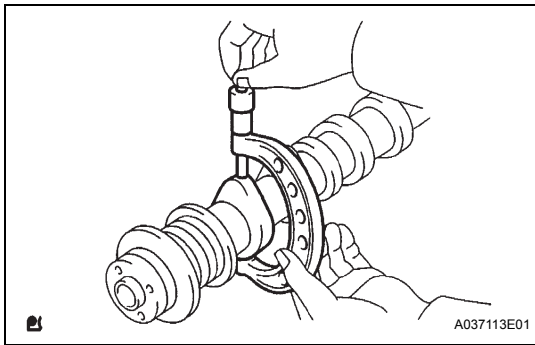

- (b) Inspect the cam lobes.
 - (1) Using a micrometer, measure the cam lobe height.

Standard cam lobe height:
44.617 to 44.717 mm (1.7566 to 1.7605 in.)

Minimum cam lobe height:
43.16 mm (1.6992 in.)

 If the cam lobe height is less than the minimum, replace the camshaft.

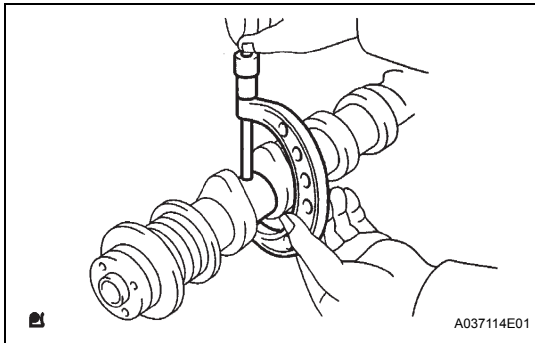

- (c) Inspect the camshaft journals.
 - (1) Using a micrometer, measure the journal diameter.

Standard journal diameter

Journal	Specified Condition
No. 1 journal	34.449 to 34.465 mm (1.3563 to 1.3569 in.)
Other journals	22.949 to 22.965 mm (0.9035 to 0.9041 in.)

If the journal diameter is not as specified, check the oil clearance.

12. INSPECT NO. 2 CAMSHAFT

- (a) Inspect the camshaft for runout.
 - (1) Place the camshaft on V-blocks.
 - (2) Using a dial indicator, measure the circle runout at the center journal.

Maximum circle runout:
0.03 mm (0.0012 in.)

 If the circle runout is greater than the maximum, replace the camshaft.

- (b) Inspect the cam lobes.
 - (1) Using a micrometer, measure the cam lobe height.

Standard cam lobe height:
44.666 to 44.766 (1.7585 to 1.7624 in.)

Minimum cam lobe height:
44.52 mm (1.7528 in.)

 If the cam lobe height is less than the minimum, replace the camshaft.

- (c) Inspect the camshaft journals.
 - (1) Using a micrometer, measure the journal diameter.

Standard journal diameter

Journal	Specified Condition
No. 1 journal	34.449 to 34.465 mm (1.3563 to 1.3569 in.)
Other journals	22.949 to 22.965 mm (0.9035 to 0.9041 in.)

If the journal diameter is not as specified, check the oil clearance.

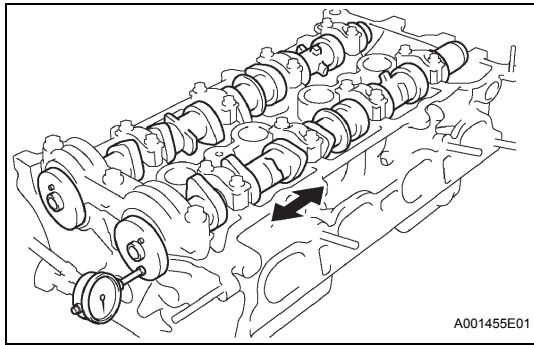

13. INSPECT CAMSHAFT THRUST CLEARANCE

- (a) Install the camshafts.
- (b) Using a dial indicator, measure the thrust clearance while moving the camshaft back and forth.

Standard thrust clearance:

0.040 to 0.095 mm (0.0016 to 0.0037 in.)

Maximum thrust clearance:

0.11 mm (0.0043 in.)

If the thrust clearance is greater than the maximum, replace the camshaft. If necessary, replace the bearing caps and the cylinder head together.

14. INSPECT CAMSHAFT OIL CLEARANCE

- (a) Clean the bearing caps and the camshaft journals.
- (b) Place the camshafts on the cylinder head.

- (c) Lay a strip of Plastigage across each of the camshaft journals.

- (d) Install the bearing caps (see page [EM-97](#)).

NOTICE:

Do not turn the camshaft.

- (e) Remove the bearing caps.

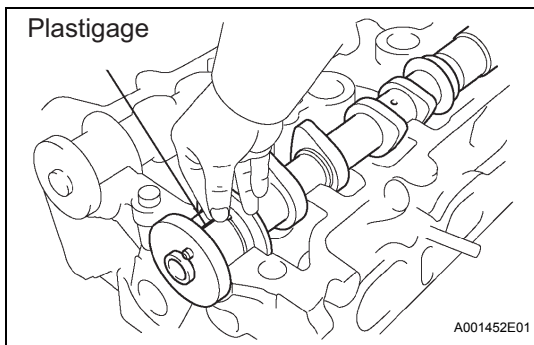

- (f) Measure the Plastigage at its widest point.

Standard oil clearance:

0.035 to 0.072 mm (0.0014 to 0.0028 in.)

Maximum oil clearance:

0.08 mm (0.0031 in.)

If the oil clearance is greater than the maximum, replace the camshaft. If necessary, replace the bearing caps and the cylinder head together.

NOTICE:

Completely remove the Plastigage after the measurement.

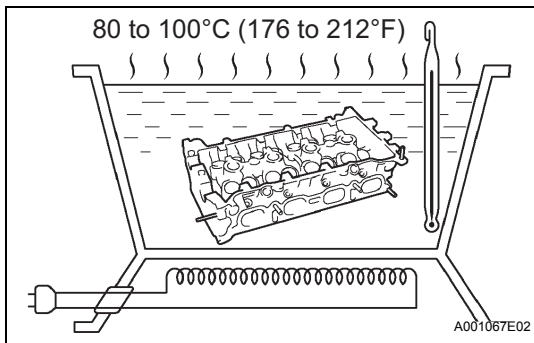
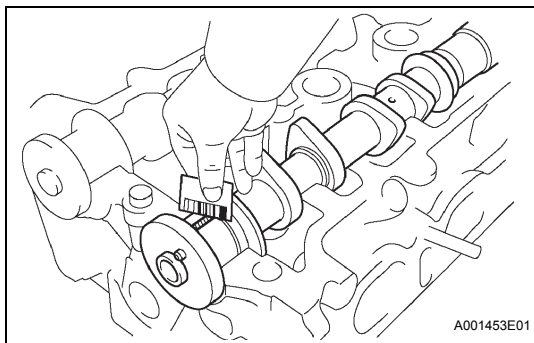

REPLACEMENT

1. REMOVE INTAKE VALVE GUIDE BUSH

- (a) Heat the cylinder head to 80 to 100°C (176 to 212°F).

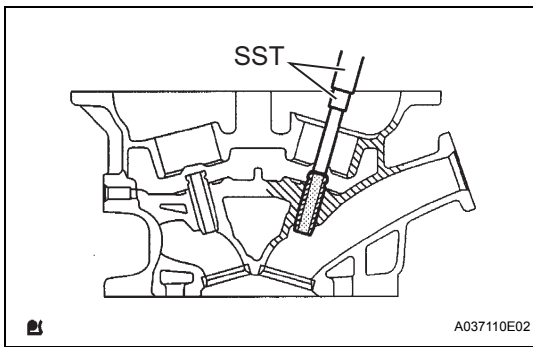

- (b) Using SST and a hammer, tap out the guide bushing.

SST 09201-10000 (09201-01050), 09950-70010 (09951-07100)

2. REMOVE EXHAUST VALVE GUIDE BUSH

- (a) Heat the cylinder head to 80 to 100°C (176 to 212°F).

- (b) Using SST and a hammer, tap out the guide bushing.

SST 09201-10000 (09201-01050), 09950-70010 (09951-07100)

3. INSTALL INTAKE VALVE GUIDE BUSH

- (a) Using a caliper gauge, measure the bushing bore diameter of the cylinder head.

Inside Diameter:

9.685 to 9.706 mm (0.3813 to 0.3821 in.)

If the bushing bore diameter of the cylinder head is greater than 9.706 mm (0.3821 in.), machine the bushing bore to the dimension of 9.735 to 9.755 mm (0.3833 to 0.3841 in.).

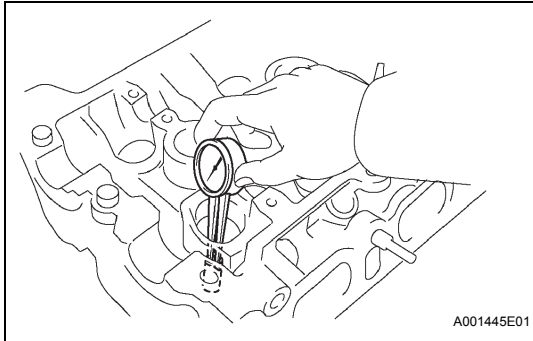

Bushing bore diameter mm (in.)	Bushing size
9.685 to 9.706 (0.3813 to 0.3821)	STD
9.735 to 9.755 (0.3833 to 0.3841)	O/S 0.05

- (b) Heat the cylinder head to 80 to 100°C (176 to 212°F).

- (c) Using SST and a hammer, tap a new guide bushing in to the specified protrusion height.

SST 09201-10000 (09201-01050), 09950-70010 (09951-07100)

Protrusion height:

9.0 to 9.4 mm (0.354 to 0.370 in.)

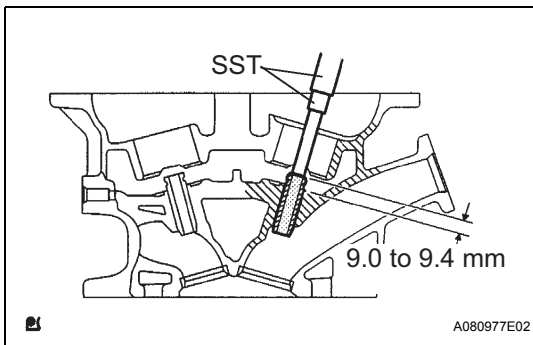

- (d) Using a sharp 5 mm reamer, ream the guide bushing to obtain the standard oil clearance between the guide bushing and valve stem.

Standard oil clearance:

0.025 to 0.060 mm (0.0010 to 0.0024 in.)

4. INSTALL EXHAUST VALVE GUIDE BUSH

- (a) Using a caliper gauge, measure the bushing bore diameter of the cylinder head.

Inside Diameter:

9.685 to 9.706 mm (0.3813 to 0.3821 in.)

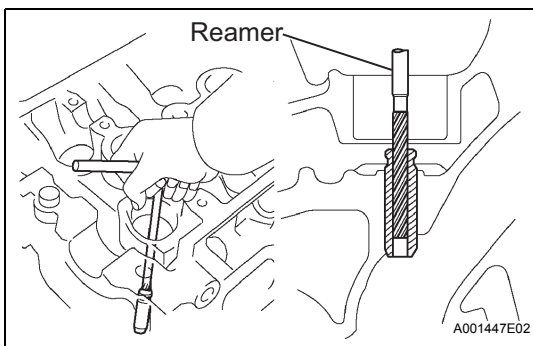

If the bushing bore diameter of the cylinder head is greater than 9.706 mm (0.3821 in.), machine the bushing bore to the dimension of 9.735 to 9.755 mm (0.3833 to 0.3841 in.).

Bushing bore diameter mm (in.)	Bushing size
9.685 to 9.706 (0.3813 to 0.3821)	STD
9.735 to 9.755 (0.3833 to 0.3841)	O/S 0.05

- (b) Heat the cylinder head to 80 to 100°C (176 to 212°F).
- (c) Using SST and a hammer, tap a new guide bushing in to the specified protrusion height.

SST 09201-10000 (09201-01050), 09950-70010 (09951-07100)

Protrusion height:

9.0 to 9.4 mm (0.354 to 0.370 in.)

- (d) Using a sharp 5 mm reamer, ream the guide bushing to obtain the standard oil clearance between the guide bushing and valve stem.

Standard oil clearance:

0.030 to 0.065 mm (0.0012 to 0.0026 in.)

REASSEMBLY

1. INSTALL CAMSHAFT BEARING CAP SETTING RING PIN

- (a) Using a plastic-faced hammer, tap a new ring pin in to the specified protrusion height.

Protrusion height:

8.5 to 9.5 mm (0.335 to 0.374 in.)

2. INSTALL STUD BOLT

- (a) Using "Torx" socket wrenches E5 and E7, install the 7 stud bolts.

Torque:

Stud bolt A:

10 N*m (102 kgf*cm, 7.4 ft.*lbf)

Stud bolt B:

4.0 N*m (41 kgf*cm, 35 in.*lbf)

Stud bolt C:

10 N*m (102 kgf*cm, 7.4 ft.*lbf)

Stud bolt D:

9.0 N*m (92 kgf*cm, 80 in.*lbf)

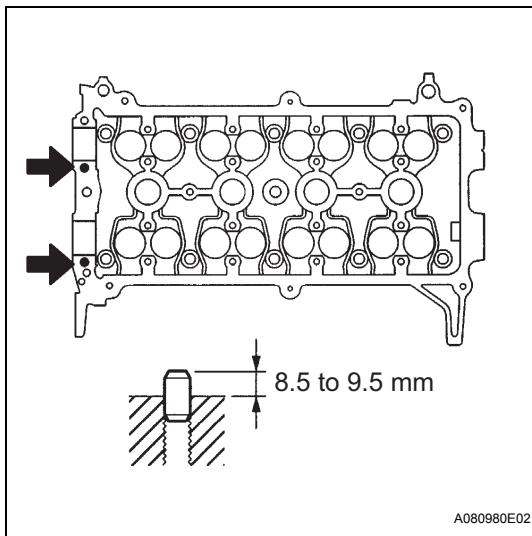

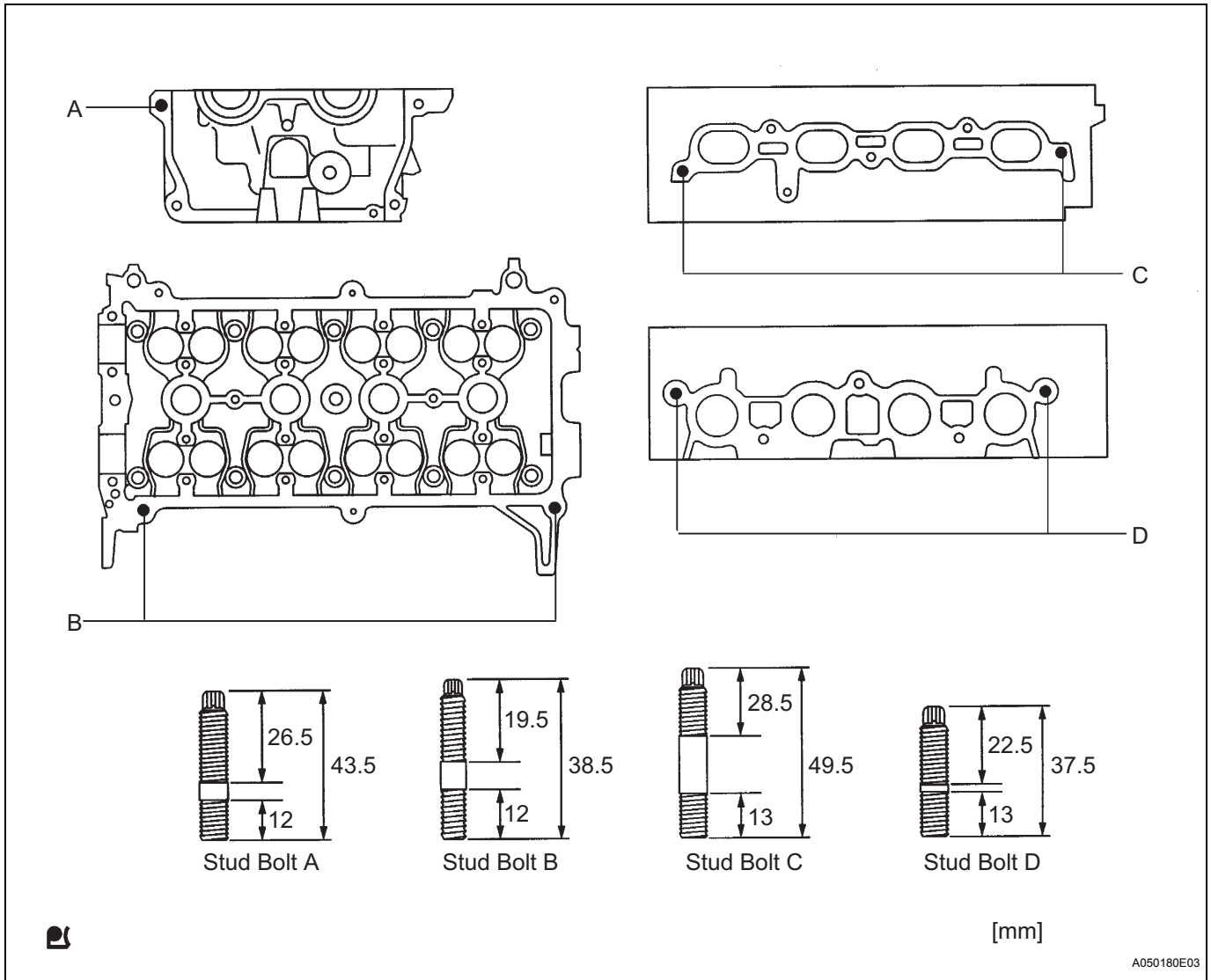

A050180E03

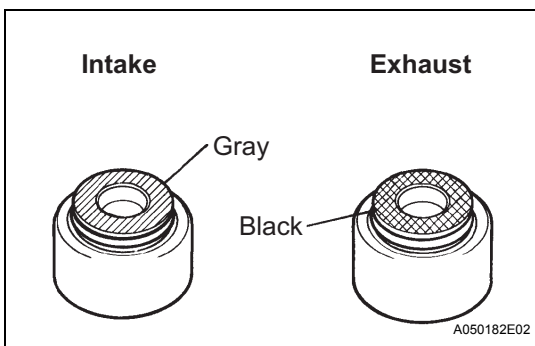

3. INSTALL VALVE STEM OIL SEAL

- (a) Apply a light coat of engine oil to new valve stem oil seals.

NOTICE:

Installing the oil seals for the intake and exhaust onto the opposite valve guide bush as may cause failures.

HINT:

The intake valve oil seal is gray and the exhaust valve oil seal is black.

- (b) Using SST, push in the oil seals.

SST 09201-41020

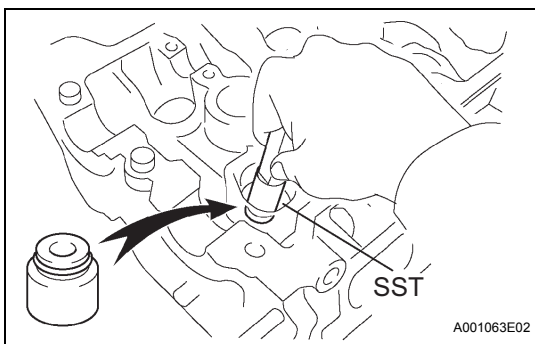

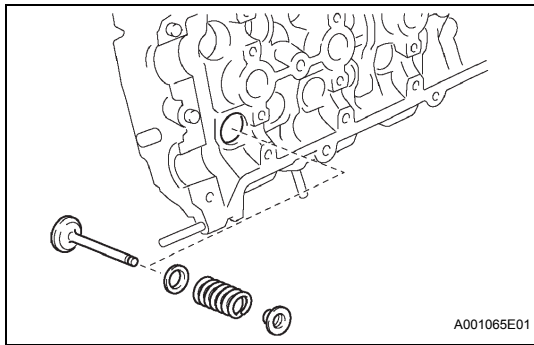

4. INSTALL INTAKE VALVE

- (a) Install the valve, spring seat, valve spring, and spring retainer.

NOTICE:

Install the parts in their original locations in the original order.

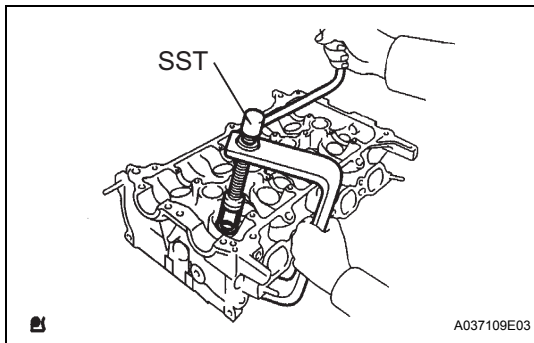

- (b) Using SST, compress the valve spring and place the 2 retainer locks around the valve stem.

SST 09202-70020 (09202-00010)

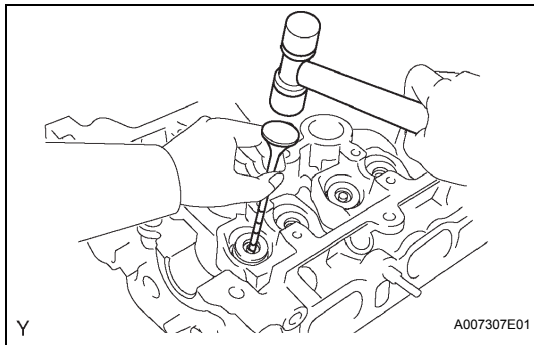

- (c) Using a plastic-faced hammer and the valve stem (not in use) with its tip wrapped in tape, gently tap the valve stem tip to ensure a proper fit.

NOTICE:

Do not damage the valve stem tip.

5. INSTALL EXHAUST VALVE

- (a) Install the valve, spring seat, valve spring, and spring retainer.

- (b) Using SST, compress the valve spring and place the 2 retainer locks around the valve stem.

SST 09202-70020 (09202-00010)

- (c) Using a plastic-faced hammer and the valve stem (not in use) with its tip wrapped in tape, lightly tap the valve stem tip to ensure a proper fit.

NOTICE:

Do not damage the valve stem tip.

6. INSTALL OIL CONTROL VALVE FILTER

- (a) Install the oil control valve filter.

7. INSTALL WITH HEAD TAPER SCREW PLUG NO. 2

- (a) Using an 8 mm hexagon wrench, install the taper screw plug and a new gasket.

Torque: 30 N*m (306 kgf*cm, 22 ft.*lbf)

8. INSTALL VALVE LIFTER

- (a) Apply a light coat of engine oil to the 16 valve lifters.
 (b) Install the 16 valve lifters.
 (c) Check that the valve lifters rotate smoothly by hand.

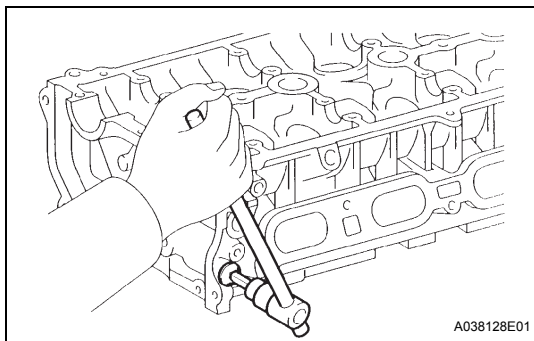

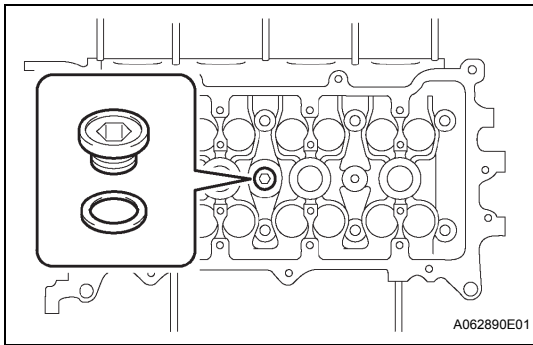

- 9. INSTALL WITH HEAD TAPER SCREW PLUG NO. 1**
 (a) Using a 10 mm socket hexagon wrench, install the taper screw plug with a new gasket.
Torque: 44 N*m (449 kgf*cm, 33 ft.*lbf)

INSTALLATION

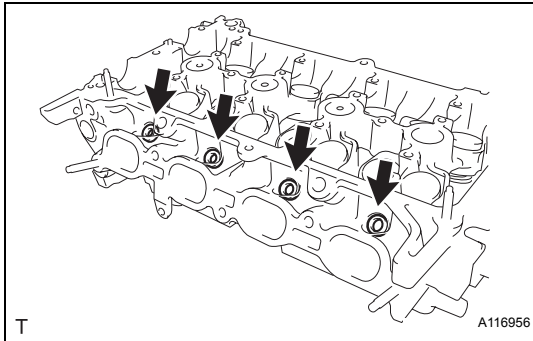

- 1. INSTALL INJECTOR VIBRATION INSULATOR**
 (a) Install 4 new injector vibration insulators onto the cylinder head.

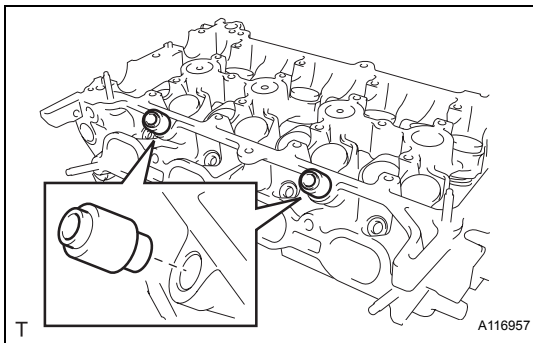

- 2. INSTALL DELIVERY PIPE NO. 1 SPACER**
 (a) Install the 2 delivery pipe No. 1 spacers onto the cylinder head.

NOTICE:

Install the delivery pipe No. 1 spacer in the correct direction.

- 3. INSTALL FUEL INJECTOR ASSEMBLY (See page [FU-17](#))**

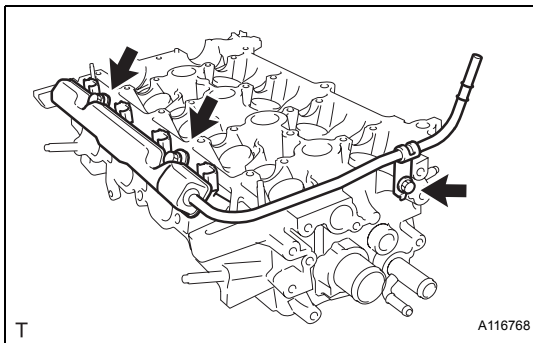

- 4. INSTALL FUEL DELIVERY PIPE SUB-ASSEMBLY**

- (a) Provisionally install the fuel delivery pipe sub-assembly with the 4 fuel injectors using the 3 bolts.

NOTICE:

- Do not drop the fuel injectors when installing the fuel delivery pipe sub-assembly.
- Check that the fuel injectors rotate smoothly after installing the fuel delivery pipe sub-assembly.

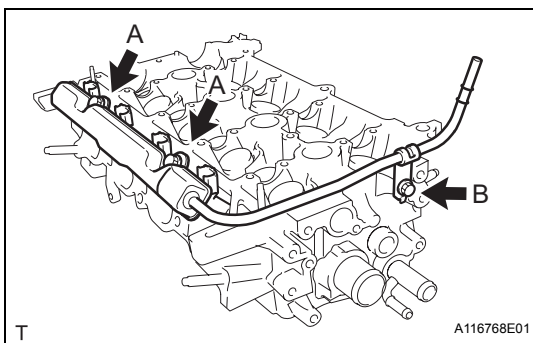

- (b) Tighten the 3 bolts to the specified torque.
Torque: 19 N*m (194 kgf*cm, 14 ft.*lbf) for bolt A
9.0 N*m (92 kgf*cm, 80 in.*lbf) for bolt B

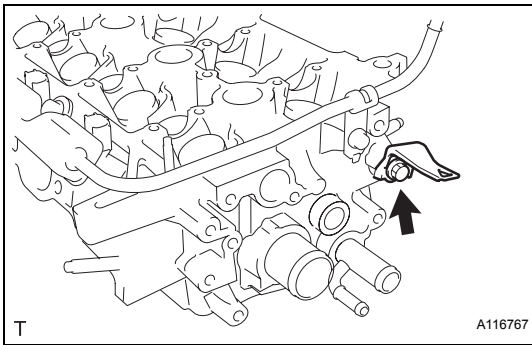
**5. INSTALL HARNESS BRACKET**

- (a) Install the harness bracket with the bolt.
Torque: 13 N*m (131 kgf*cm, 9.5 ft.*lbf)

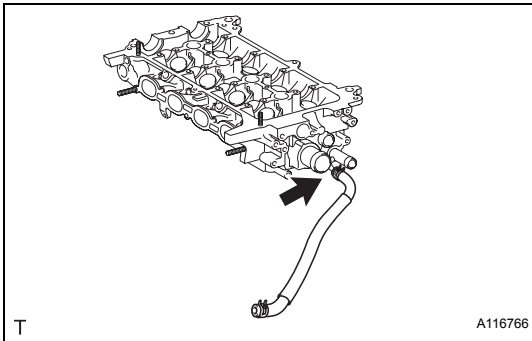
**6. INSTALL WATER BY-PASS HOSE**

- (a) Install the water by-pass hose.

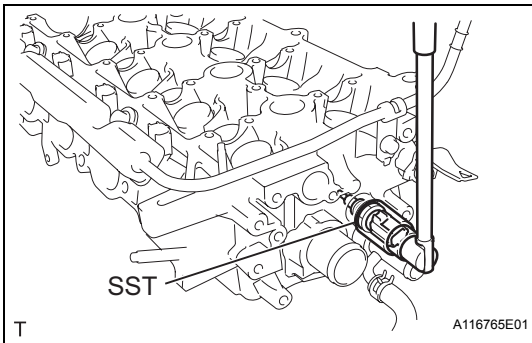
**7. INSTALL ENGINE COOLANT TEMPERATURE SENSOR**

- (a) Provisionally install the engine coolant temperature sensor through a new gasket.
 (b) Using SST, tighten the engine coolant temperature sensor.

SST 09817-33190

Torque: 20 N*m (204 kgf*cm, 15 ft.*lbf)

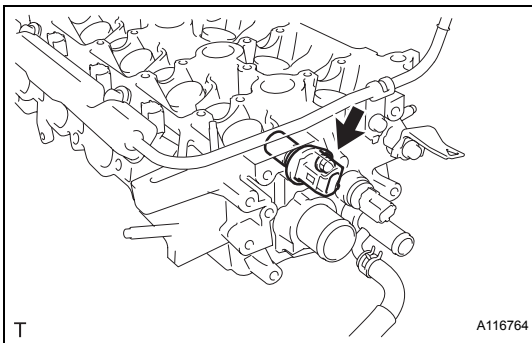
**8. INSTALL CAMSHAFT POSITION SENSOR**

- (a) Apply a light coat of engine oil to the O-ring on the camshaft position sensor.
 (b) Install the camshaft position sensor with the bolt.

Torque: 8.0 N*m (82 kgf*cm, 71 in.*lbf)

NOTICE:

Do not twist the O-ring.

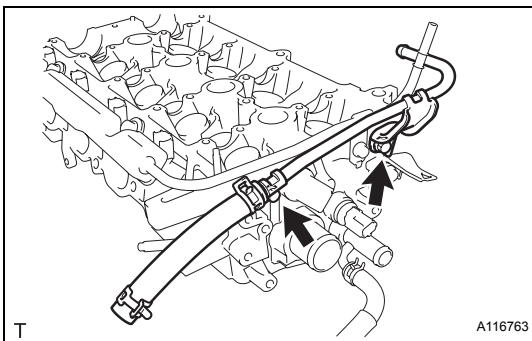
**9. INSTALL BOOSTER VACUUM TUBE**

- (a) Install the booster vacuum tube with the 2 bolts.
Torque: 9.0 N*m (92 kgf*cm, 80 in.*lbf)

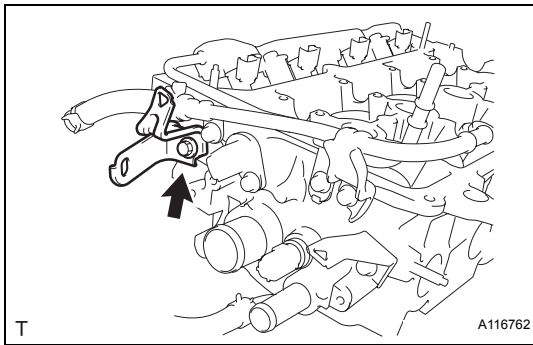
**10. INSTALL HARNESS BRACKET**

- (a) Install the harness bracket with the bolt.
Torque: 13 N*m (131 kgf*cm, 9.5 ft.*lbf)

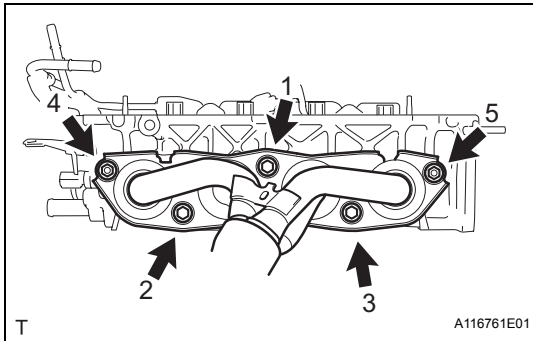
**11. INSTALL EXHAUST MANIFOLD**

- (a) Using several steps, install a new exhaust manifold gasket and the exhaust manifold with the 3 bolts and 2 nuts in the sequence shown in the illustration.
Torque: 27 N*m (275 kgf*cm, 20 ft.*lbf)

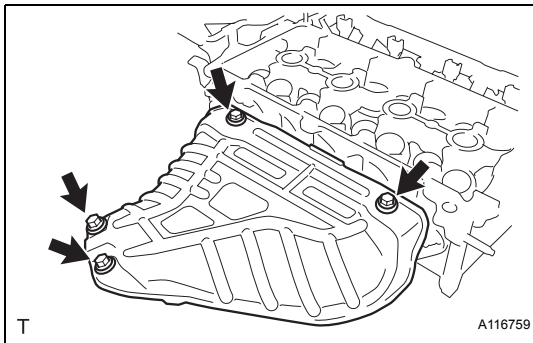
**12. INSTALL EXHAUST MANIFOLD HEAT INSULATOR NO. 1**

- (a) Install exhaust manifold heat insulator No. 1 with the 4 bolts.
Torque: 8.0 N*m (82 kgf*cm, 71 in.*lbf)

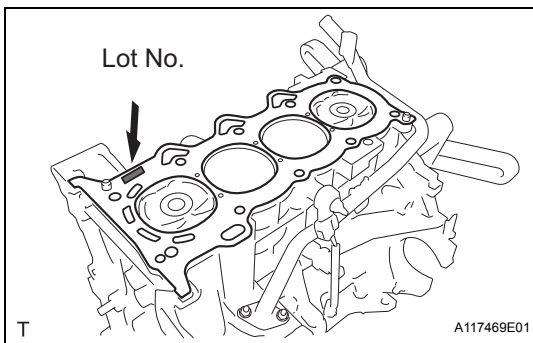
**13. INSTALL CYLINDER HEAD GASKET**

- (a) Place a new cylinder head gasket on the cylinder block with the Lot No. stamp facing upward.

NOTICE:

- Remove any oil from the contact surfaces.
- Check the mounting orientation of the cylinder head gasket.
- Place the cylinder head on the cylinder head gently in order not to damage the gasket.

14. INSTALL CYLINDER HEAD SUB-ASSEMBLY**HINT:**

The cylinder head bolts are tightened in 2 successive steps.

- (a) Apply a light coat of engine oil to the threads of the cylinder head bolts.

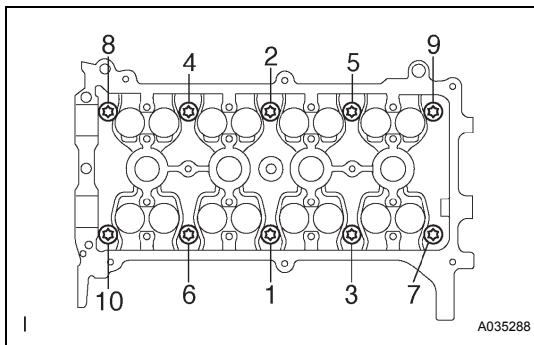

- (b) Using several steps, install and tighten the 10 cylinder head bolts and plate washers uniformly with an 8 mm bi-hexagon wrench, in the sequence shown in the illustration.

Torque: 29 N*m (300 kgf*cm, 22 ft.*lbf)

- (c) Mark the front of the cylinder head bolt with paint.

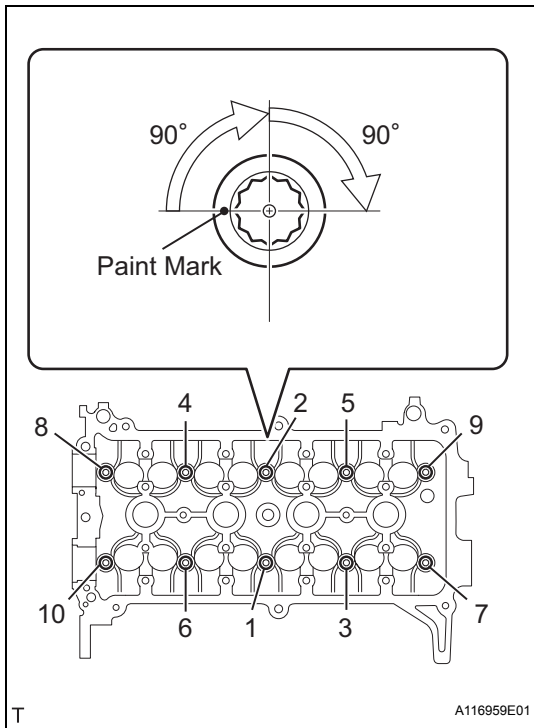

- (d) Retighten the cylinder head bolts 90° and then an additional by 90° as shown in the illustration.

- (e) Check that the paint mark is now at a 180° angle from the front.

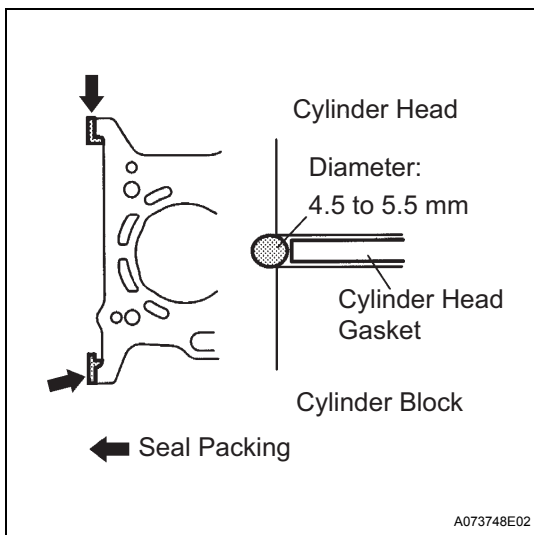

- (f) Apply a continuous bead of seal packing (Diameter 4.5 to 5.5 mm (0.177 to 0.217 in.)) as shown in the illustration.

Seal Packing:

Toyota Genuine Seal Packing Black, Three Bond 1207B or Equivalent

NOTICE:

- Remove any oil from the contact surfaces.
- Install the oil pump assembly within 3 minutes and tighten the bolts within 15 minutes of applying the seal packing.

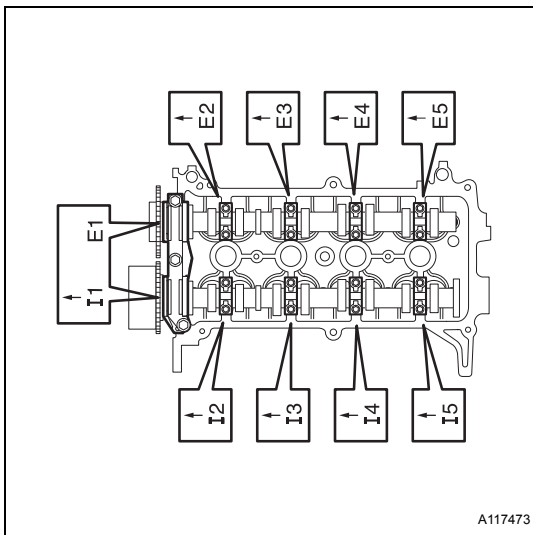

15. INSTALL CAMSHAFT

- (a) Examine the front marks and numbers and check that the sequence is as shown in the illustration. Then provisionally tighten the 19 bolts.

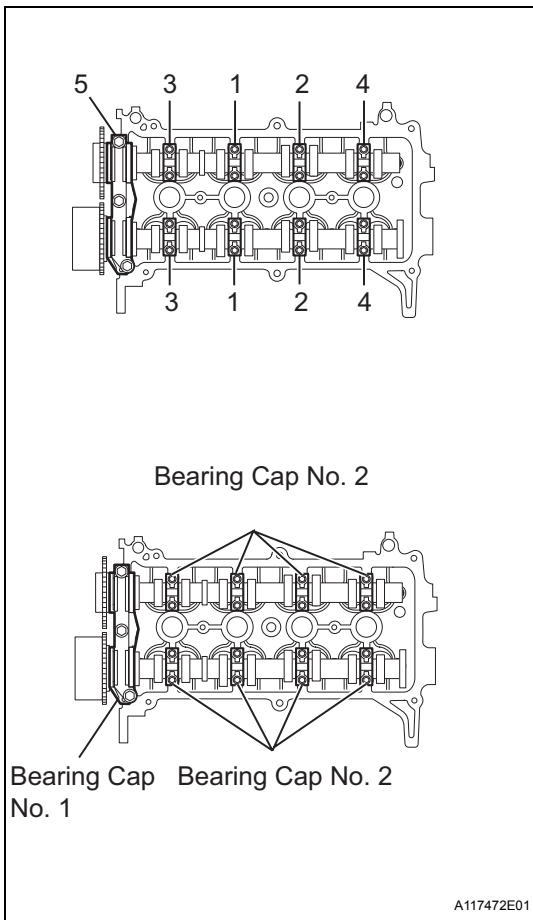

- (b) Uniformly tighten the bolts in several steps in the sequence shown in the illustration and install camshaft bearing cap No. 1 and camshaft bearing cap No. 2.

Torque: Camshaft bearing cap No. 1
 23 N*m (235 kgf*cm, 17 ft.*lbf)
Camshaft bearing cap No. 2
 13 N*m (129 kgf*cm, 9.4 ft.*lbf)

NOTICE:

Tighten each bolt uniformly while keeping the camshaft level.

16. INSTALL CHAIN SUB-ASSEMBLY (See page [EM-36](#))
17. INSTALL CHAIN TENSIONER SLIPPER (See page [EM-38](#))
18. INSTALL CHAIN TENSIONER ASSEMBLY NO. 1 (See page [EM-38](#))
19. INSTALL OIL PUMP SEAL (See page [LU-21](#))
20. INSTALL OIL PUMP ASSEMBLY (See page [LU-22](#))
21. INSTALL TRANSVERSE ENGINE ENGINE MOUNTING BRACKET (See page [LU-26](#))
22. INSTALL WATER PUMP ASSEMBLY (See page [CO-16](#))
23. INSTALL WATER PUMP PULLEY (See page [CO-16](#))
24. INSTALL CAMSHAFT TIMING OIL CONTROL VALVE ASSEMBLY (See page [ES-397](#))
25. INSTALL CRANKSHAFT POSITION SENSOR (See page [ES-403](#))
26. INSTALL CRANKSHAFT DAMPER SUB-ASSEMBLY (See page [LU-26](#))
27. INSTALL ENGINE MOUNTING INSULATOR SUB-ASSEMBLY RH (See page [LU-26](#))

28. INSTALL CYLINDER HEAD COVER SUB-ASSEMBLY (See page [FU-19](#))
29. INSTALL VENTILATION HOSE NO. 2 (See page [FU-20](#))
30. INSTALL VENTILATION HOSE (See page [FU-20](#))
31. INSTALL IGNITION COIL NO. 1 (See page [IG-9](#))
32. INSTALL GENERATOR ASSEMBLY (See page [CH-17](#))
33. INSTALL FAN AND GENERATOR V BELT (See page [EM-7](#))
34. ADJUST FAN AND GENERATOR V BELT (See page [EM-7](#))
35. INSPECT FAN AND GENERATOR V BELT (See page [EM-8](#))
36. INSTALL MANIFOLD SUPPORT BRACKET
 - (a) Install the manifold support bracket with the 3 bolts.
Torque: 44 N*m (449 kg*cm, 33 ft.*lbf)

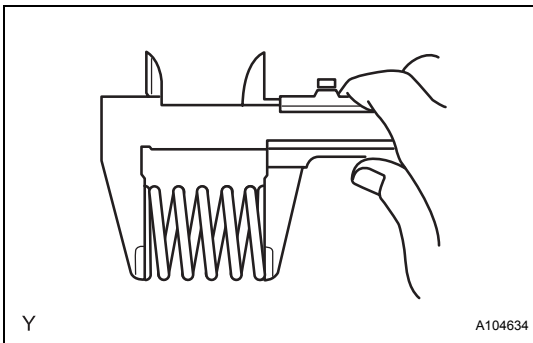
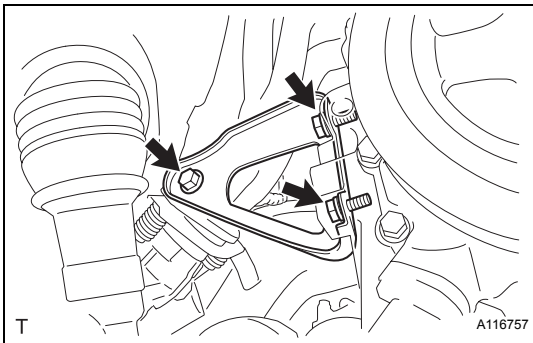

37. INSTALL EXHAUST PIPE ASSEMBLY FRONT

- (a) Using vernier calipers, measure the free length of the compression spring.

Minimum length:

40.5 mm (1.594 in.)

If the length is not as specified, replace the compression spring.

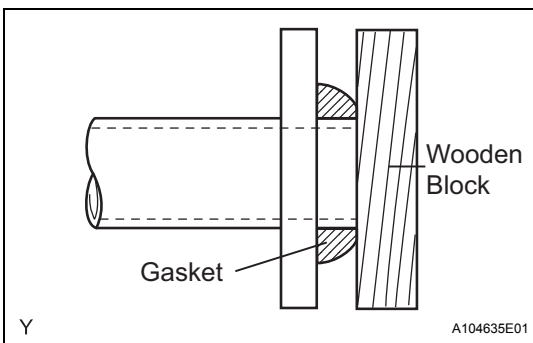

- (b) Using a plastic hammer and a wooden block, tap in a new exhaust pipe gasket until its surface is flush with the exhaust manifold.

NOTICE:

- Install the exhaust pipe gasket in the correct direction.
- Do not damage the outer surface of the exhaust pipe gasket.
- Do not reuse the exhaust pipe gasket.
- Do not push in the gasket with the exhaust pipe when installing.

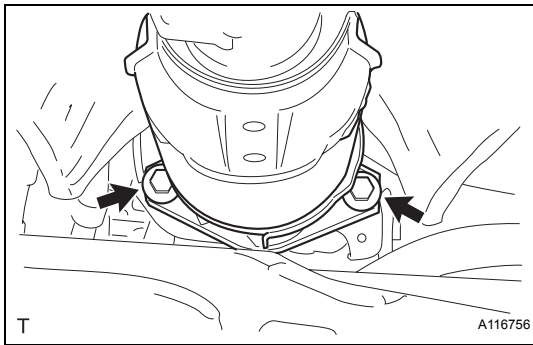

- (c) Install the exhaust front pipe assembly with the 2 compression springs and 2 bolts.
Torque: 43 N*m (439 kgf*cm, 32 ft.*lbf)

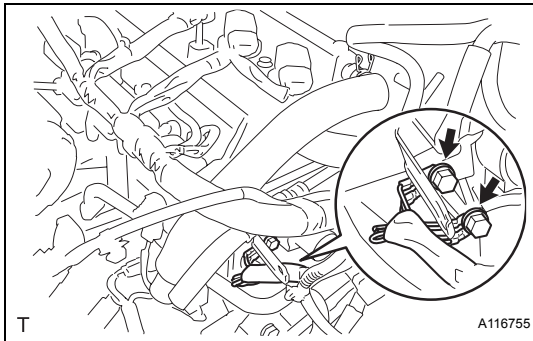

38. CONNECT WIRE HARNESS

- (a) Connect the wire harness with the 2 bolts.
Torque: 13 N*m (133 kgf*cm, 10 ft.*lbf)

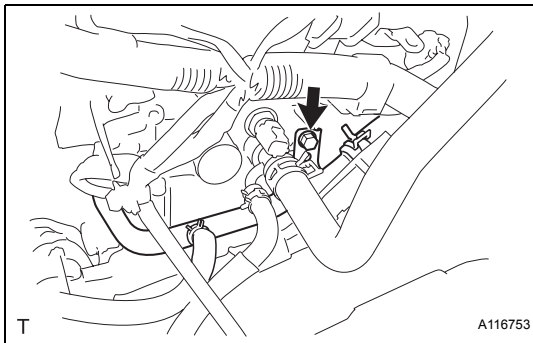

39. INSTALL WATER BY-PASS HOSE NO. 1

- (a) Install water by-pass pipe No. 1 with the bolt.
Torque: 9.0 N*m (92 kgf*cm, 80 in.*lbf)

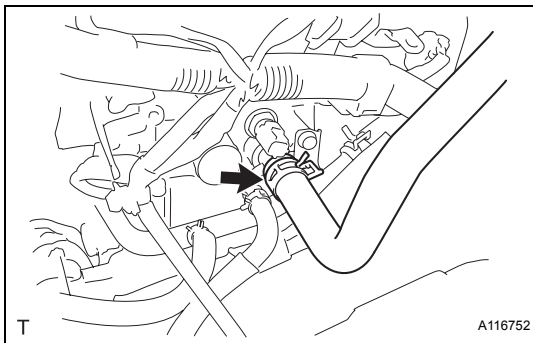

40. CONNECT HEATER WATER INLET HOSE A

- (a) Connect heater water inlet hose A.

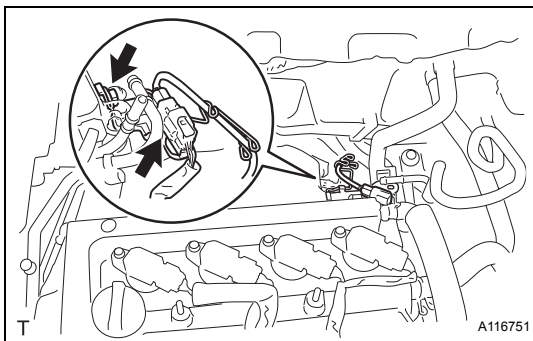

41. CONNECT HEATED OXYGEN SENSOR CONNECTOR

- (a) Connect the heated oxygen sensor connector.
 (b) Install the sensor bracket with the bolt.

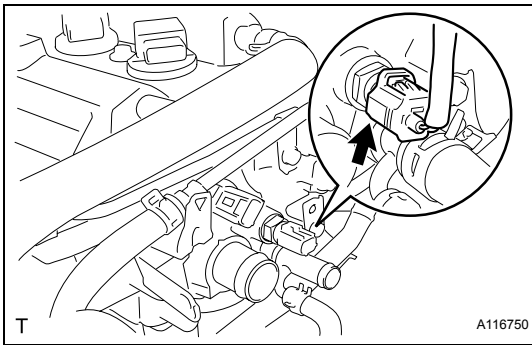

42. CONNECT ENGINE COOLANT TEMPERATURE SENSOR CONNECTOR

- (a) Connect the engine coolant temperature sensor connector.

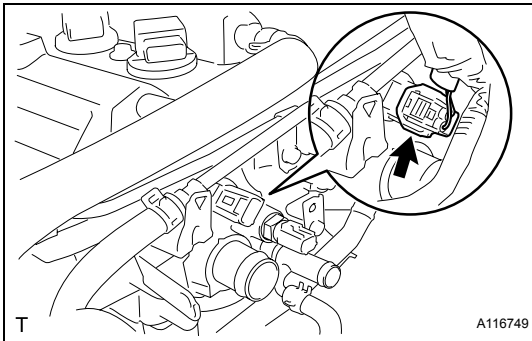

43. CONNECT CAMSHAFT POSITION SENSOR CONNECTOR

- (a) Connect the camshaft position sensor connector.

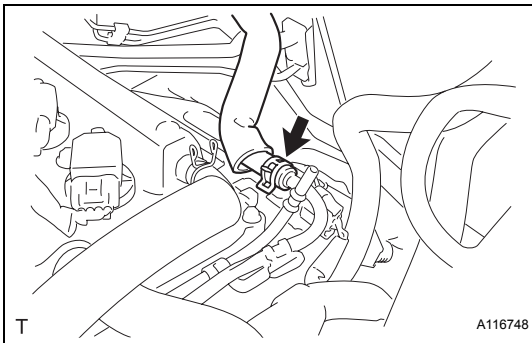

44. CONNECT BOOSTER VACUUM TUBE

- (a) Connect the booster vacuum tube.

45. CONNECT FUEL TUBE SUB-ASSEMBLY (See page [FU-18](#))

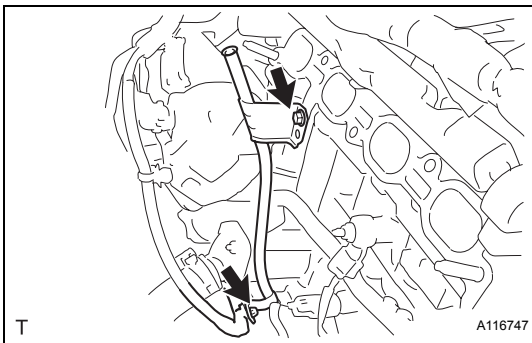

46. INSTALL OIL LEVEL GAUGE GUIDE

- (a) Apply engine oil to a new O-ring.
 (b) Install the oil level gauge guide with the bolt through a new O-ring.
Torque: 9.0 N*m (92 kgf*cm, 80 in.*lbf)
 (c) Install the wire harness.

47. INSTALL INTAKE MANIFOLD

- (a) Install a new gasket onto the intake manifold.

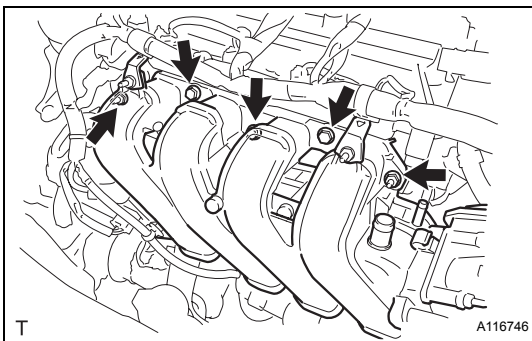

- (b) Install the intake manifold with the 3 bolts and 2 nuts.

Torque: 30 N*m (306 kgf*cm, 22 ft.*lbf)

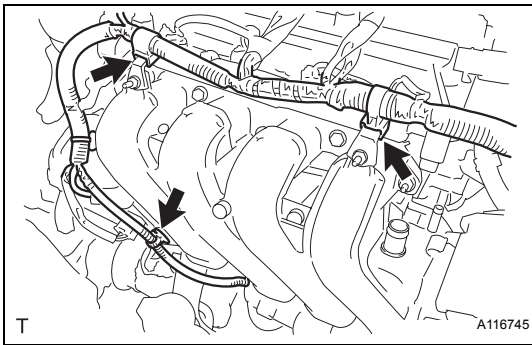

- (c) Connect the 3 wire harness clamps shown in the illustration.

48. INSTALL OIL LEVEL GAUGE SUB-ASSEMBLY

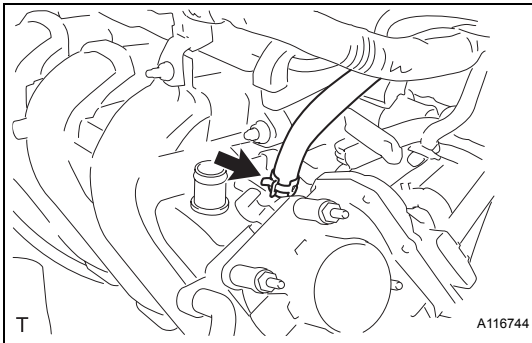

49. CONNECT UNION TO CONNECTOR TUBE HOSE

- (a) Connect the union to connector tube hose.

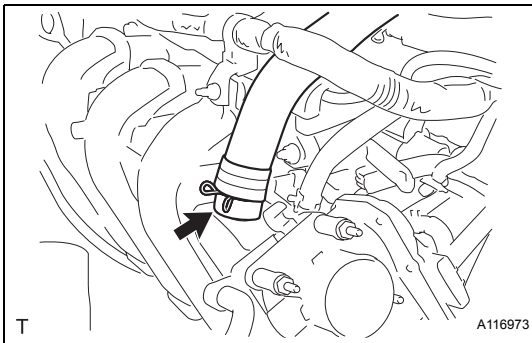

50. CONNECT VENTILATION HOSE

- (a) Connect the ventilation hose.

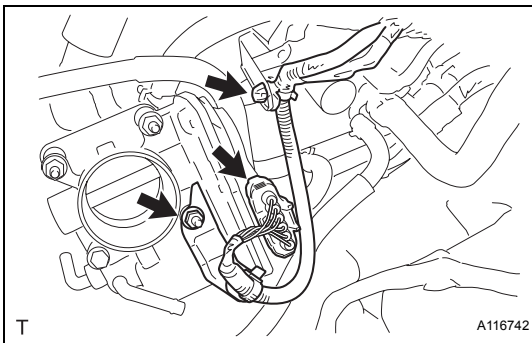

51. CONNECT THROTTLE WITH MOTOR BODY CONNECTOR

- (a) Install the throttle with motor body connector bracket with the nut.

Torque: 9.0 N*m (92 kgf*cm, 80 in.*lbf)

- (b) Connect the throttle with motor body connector.
(c) Connect the wire harness clamp.

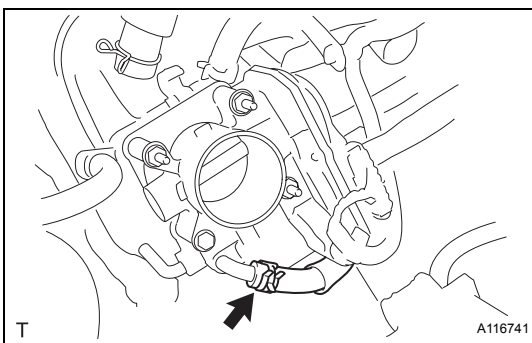

52. CONNECT WATER BY-PASS HOSE

- (a) Connect the water by-pass hose.

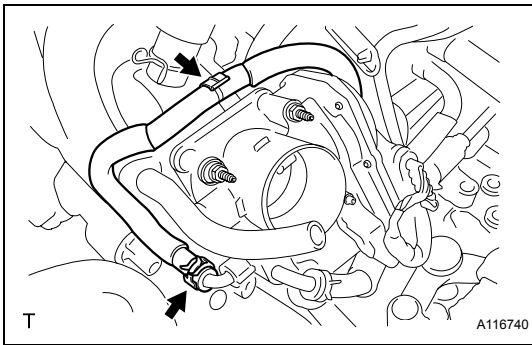
**53. CONNECT WATER BY-PASS HOSE NO. 2**

- (a) Connect water by-pass hose No. 2.

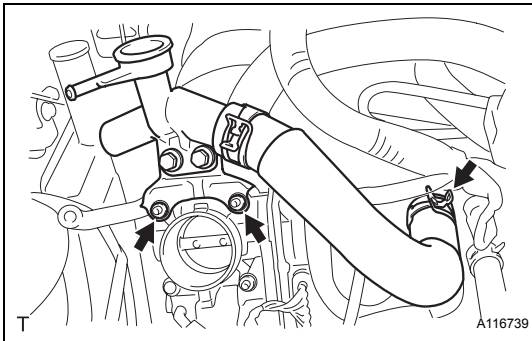
**54. INSTALL WATER FILLER SUB-ASSEMBLY**

- (a) Install the water filler sub-assembly with the 2 nuts.
Torque: 7.5 N*m (76 kgf*cm, 66 in.*lbf)
 (b) Connect radiator hose No. 1 to the cylinder head.

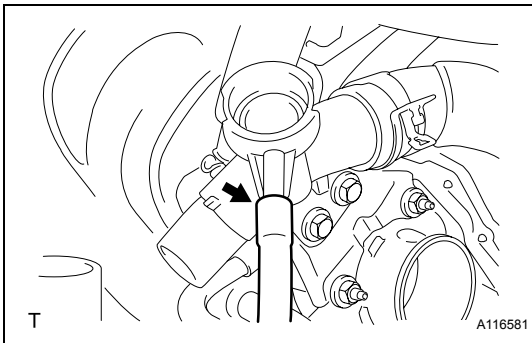
**55. CONNECT RESERVE TANK HOSE**

- (a) Connect the reserve tank hose.

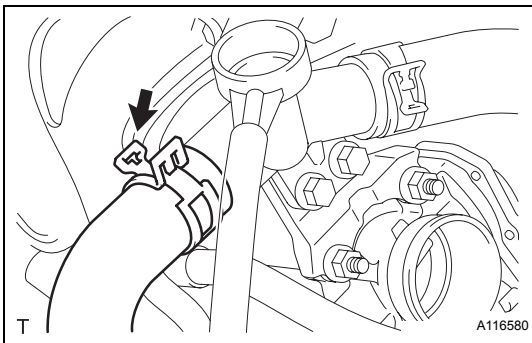
**56. CONNECT RADIATOR HOSE NO. 3**

- (a) Connect radiator hose No. 3.

57. INSTALL AIR CLEANER CAP SUB-ASSEMBLY WITH AIR CLEANER HOSE NO. 1 (See page [ES-414](#))**58. INSTALL BATTERY TRAY****59. INSTALL BATTERY****60. ADD ENGINE OIL****61. ADD ENGINE COOLANT (See page [CO-8](#))****62. CHECK ENGINE OIL LEVEL (See page [LU-1](#))****63. CHECK FOR ENGINE OIL LEAKAGE****64. CHECK FOR ENGINE COOLANT LEAKAGE (See page [CO-1](#))****65. CHECK FOR EXHAUST GAS LEAKAGE****66. CHECK FOR FUEL LEAKAGE (See page [FU-7](#))****67. INSTALL CYLINDER HEAD COVER NO. 2 (See page [IG-10](#))**

68. INSTALL ENGINE UNDER COVER RH
69. INSTALL FRONT WHEEL RH
70. INSTALL COWL TOP PANEL OUTER (for Hatchback)
(See page [EM-146](#))
71. INSTALL COWL TOP PANEL OUTER (for Sedan) (See
page [ES-434](#))
72. INSTALL COWL TO REGISTER DUCT SUB-
ASSEMBLY NO. 2 (for Hatchback) (See page [EM-147](#))
73. INSTALL FRONT AIR SHUTTER SEAL RH (for Sedan)
(See page [ES-435](#))
74. INSTALL FRONT WIPER MOTOR AND LINK (for
Hatchback) (See page [WW-21](#))
75. INSTALL FRONT WIPER MOTOR AND LINK (for
Sedan) (See page [WW-12](#))
76. INSTALL COWL TOP VENTILATOR LOUVER LH (for
Hatchback) (See page [WW-21](#))
77. INSTALL COWL TOP VENTILATOR LOUVER SUB-
ASSEMBLY (for Hatchback) (See page [WW-21](#))
78. INSTALL COWL TOP VENTILATOR LOUVER SUB-
ASSEMBLY (for Sedan) (See page [WW-12](#))
79. INSTALL COWL SIDE VENTILATOR SUB-ASSEMBLY
LH (for Sedan) (See page [WW-13](#))
80. INSTALL COWL SIDE VENTILATOR SUB-ASSEMBLY
RH (for Sedan) (See page [WW-13](#))
81. INSTALL HOOD TO COWL TOP SEAL (for
Hatchback) (See page [WW-22](#))
82. INSTALL FRONT WIPER ARM AND BLADE
ASSEMBLY LH (for Hatchback) (See page [WW-22](#))
83. INSTALL FRONT WIPER ARM AND BLADE
ASSEMBLY LH (for Sedan) (See page [WW-13](#))
84. INSTALL FRONT WIPER ARM AND BLADE
ASSEMBLY RH (for Hatchback) (See page [WW-23](#))
85. INSTALL FRONT WIPER ARM AND BLADE
ASSEMBLY RH (for Sedan) (See page [WW-14](#))
86. INSTALL FRONT WIPER ARM HEAD CAP (for
Hatchback) (See page [WW-23](#))
87. INSTALL FRONT WIPER ARM HEAD CAP (for Sedan)
(See page [WW-15](#))

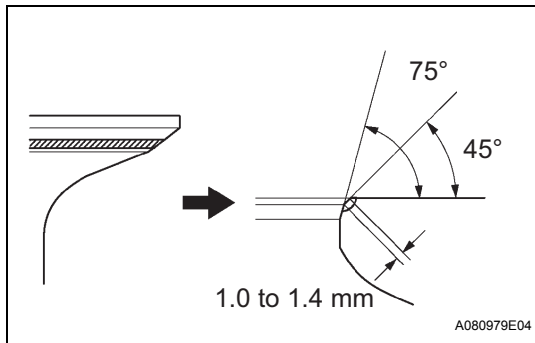
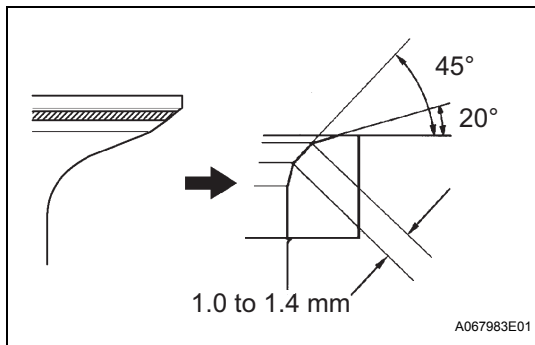

REPAIR

1. REPAIR INTAKE VALVE

- (a) Repair the intake valve seat.

NOTICE:

Releasing the seat-cutter pressure gradually helps to make the valve seat face smoother.

- (b) If the seating is too high on the valve face, use 20° and 45° cutters to correct the seat.

- (c) If the seating is too low on the valve face, use 75° and 45° cutters to correct the seat.

- (d) Hand-lap the valve and valve seat with an abrasive compound.

- (e) Recheck the valve seating position.

2. REPAIR EXHAUST VALVE

NOTICE:

Releasing the seat-cutter pressure gradually helps to make the valve seat face smoother.

- (a) If the seating is too high on the valve face, use 20° and 45° cutters to correct the seat.

- (b) If the seating is too low on the valve face, use 75° and 45° cutters to correct the seat.

- (c) Hand-lap the valve and valve seat with an abrasive compound.

- (d) Recheck the valve seating position.

ENGINE ASSEMBLY

COMPONENTS

EM

for Hatchback:

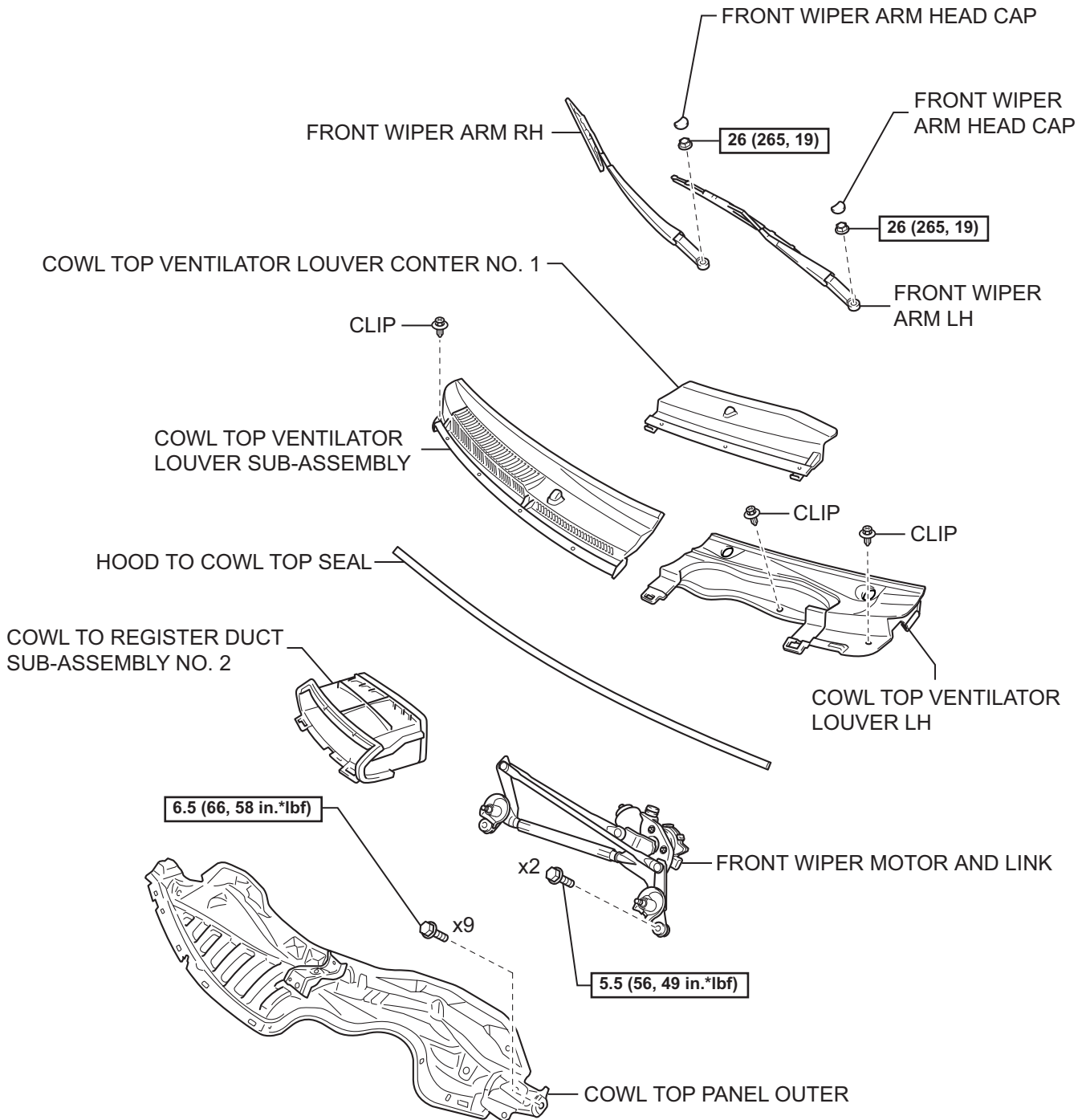

N*m (kgf*cm, ft*lbf) : Specified torque

for Sedan:

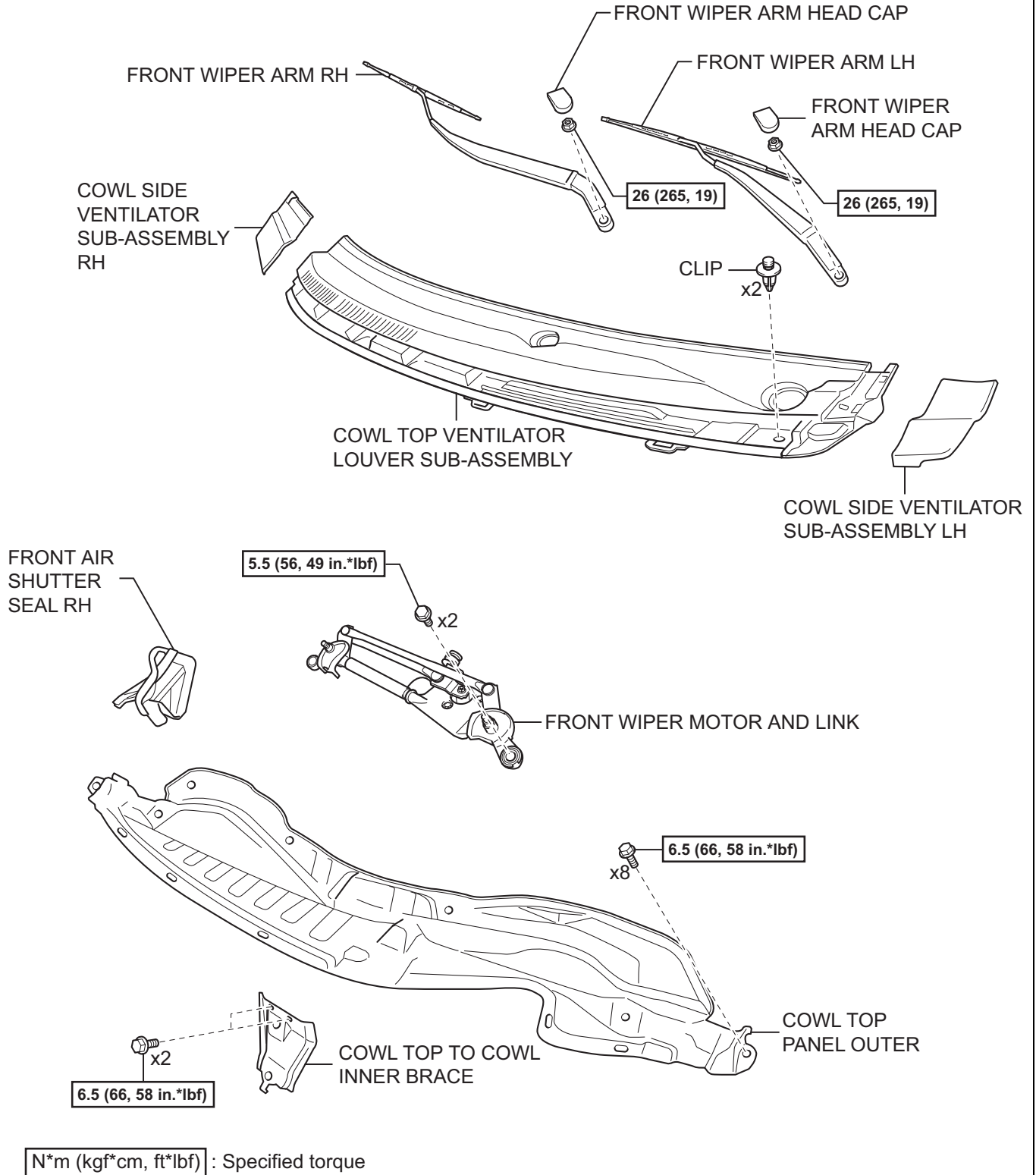

EM

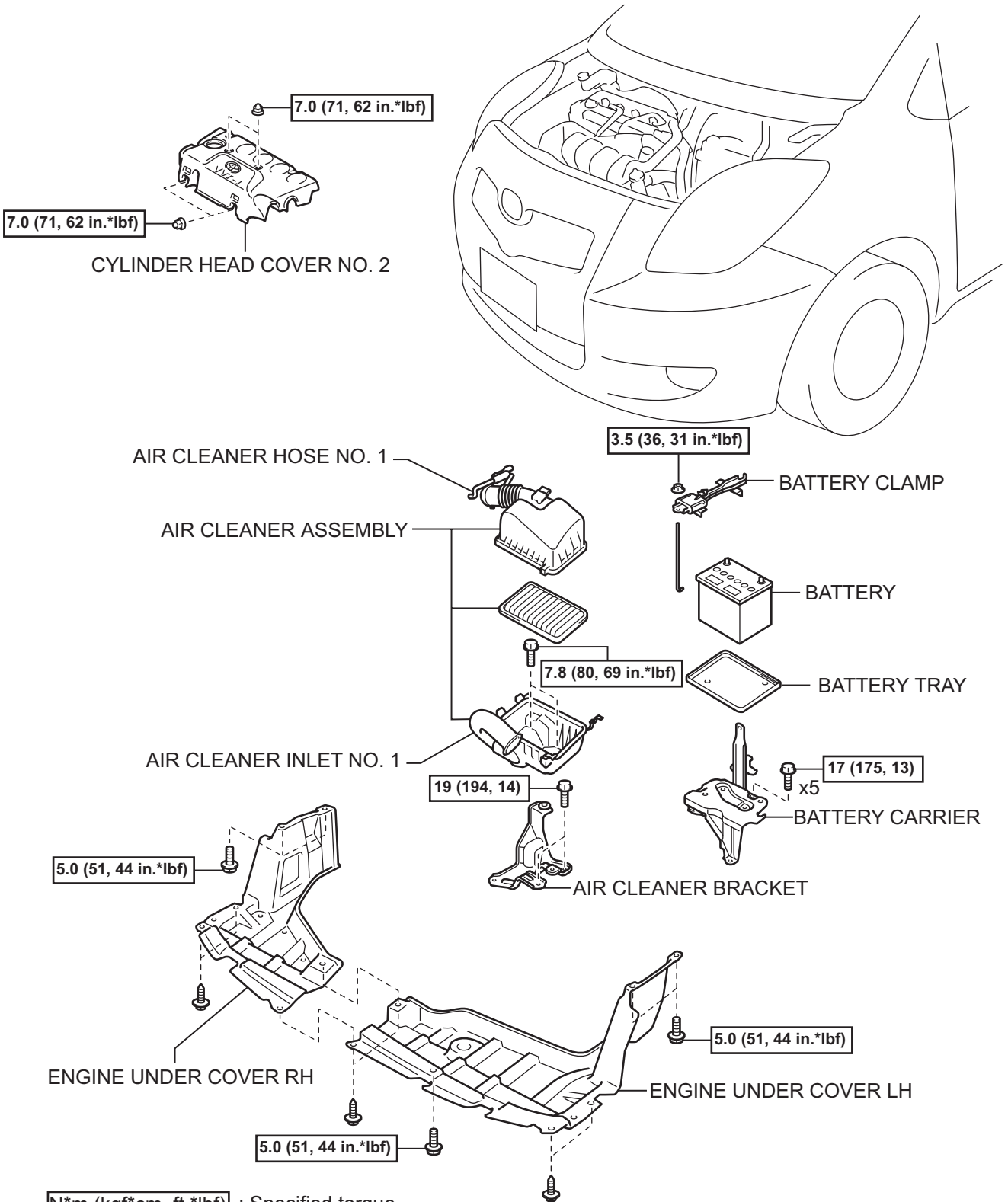

EM

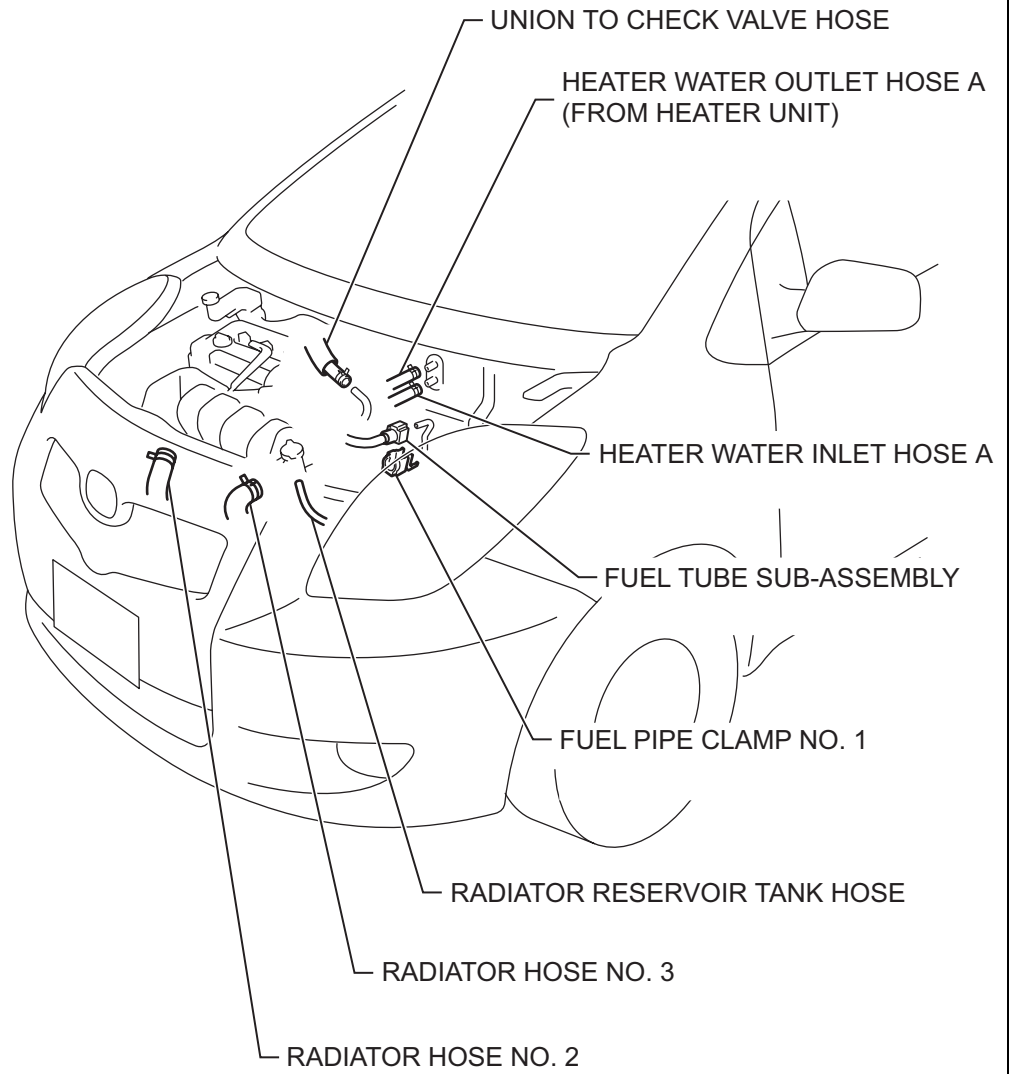

for Hatchback:

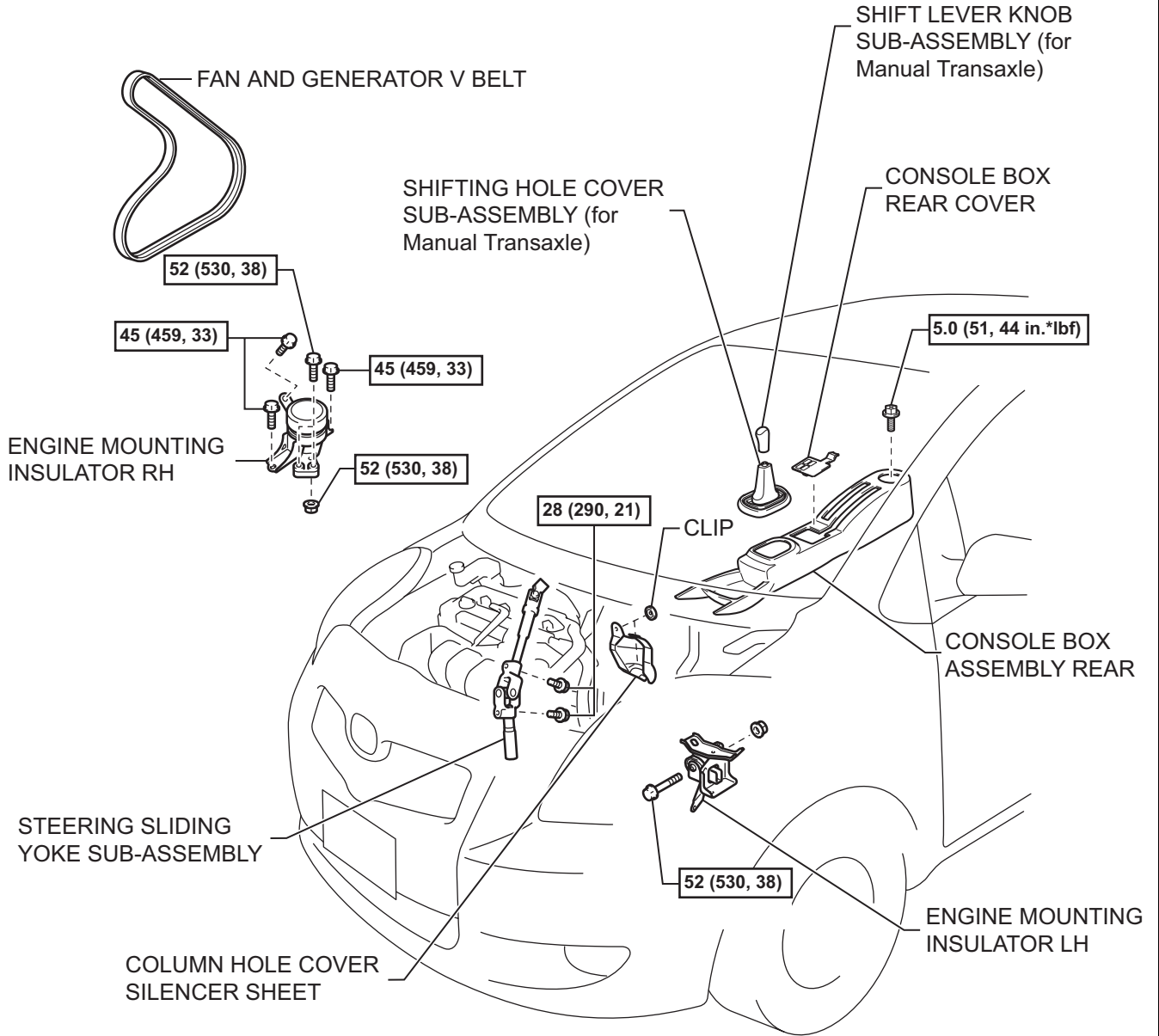

N*m (kgf*cm, ft.*lbf) : Specified torque



for Sedan:

FAN AND GENERATOR V BELT

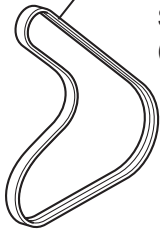

SHIFT LEVER KNOB SUB-ASSEMBLY
(for Manual Transaxle)

SHIFTING HOLE COVER SUB-ASSEMBLY

UPPER CONSOLE PANEL SUB-ASSEMBLY

CONSOLE UPPER REAR
PANEL SUB-ASSEMBLY

CONSOLE BOX
CARPET

EM

52 (530, 38)

52 (530, 38)

INSTRUMENT
PANEL FINISH
PANEL END LH

ENGINE MOUNTING
INSULATOR RH

CONSOLE BOX
ASSEMBLY REAR

STEERING SLIDING
YOKE SUB-ASSEMBLY

CLIP

INSTRUMENT PANEL
FINISH PANEL LOWER
CENTER

INSTRUMENT
PAD LOWER LH

28 (290, 21)

52 (530, 38)

COLUMN HOLE COVER
SILENCER SHEET

ENGINE MOUNTING
INSULATOR LH

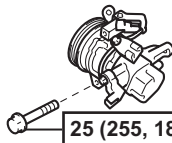

WITH PULLEY COMPRESSOR ASSEMBLY
(w/ Air Conditioning System)

25 (255, 18)

N*m (kgf*cm, ft*lbf) : Specified torque

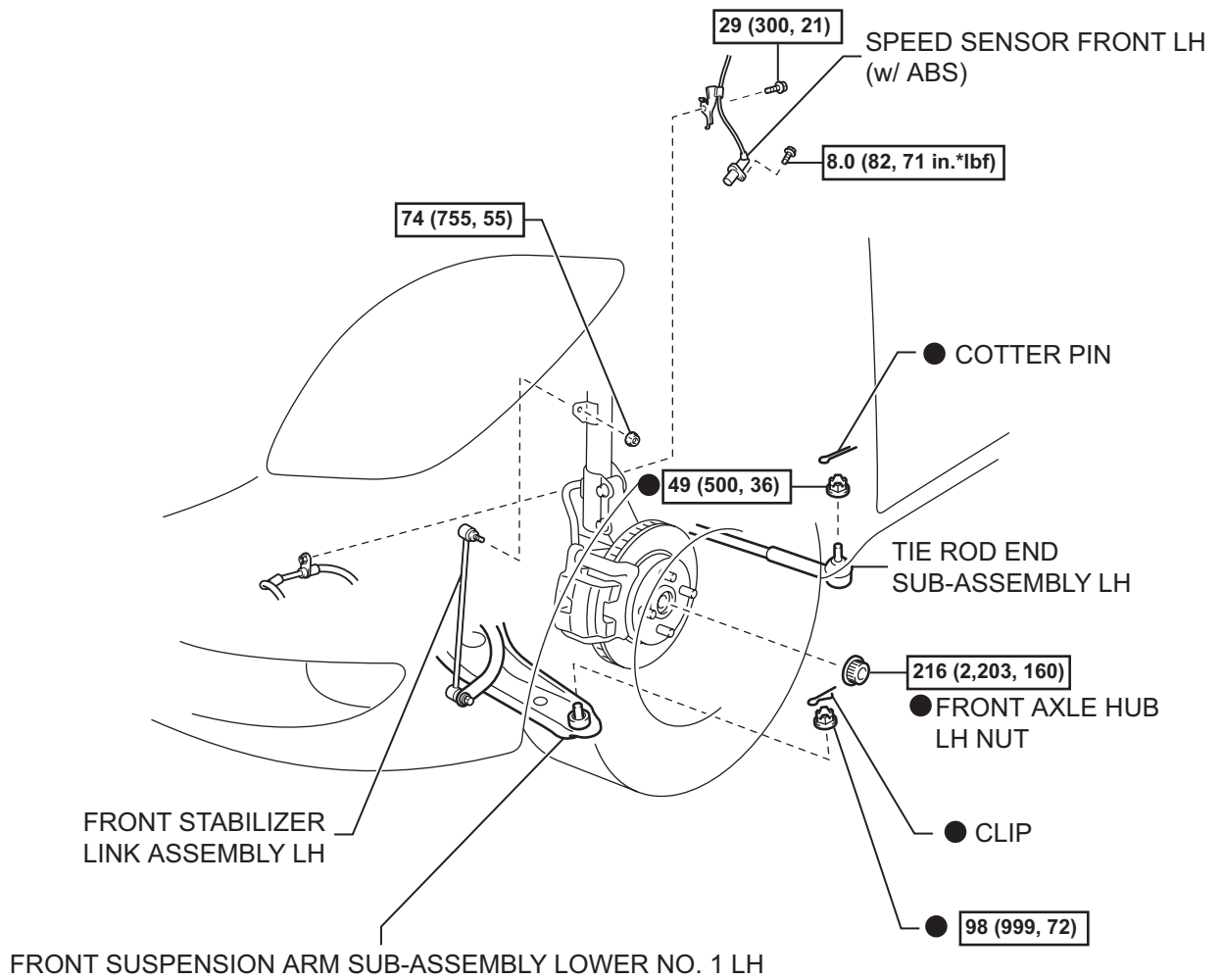

N*m (kgf*cm, ft.*lbf) : Specified torque ● Non-reusable part



EM

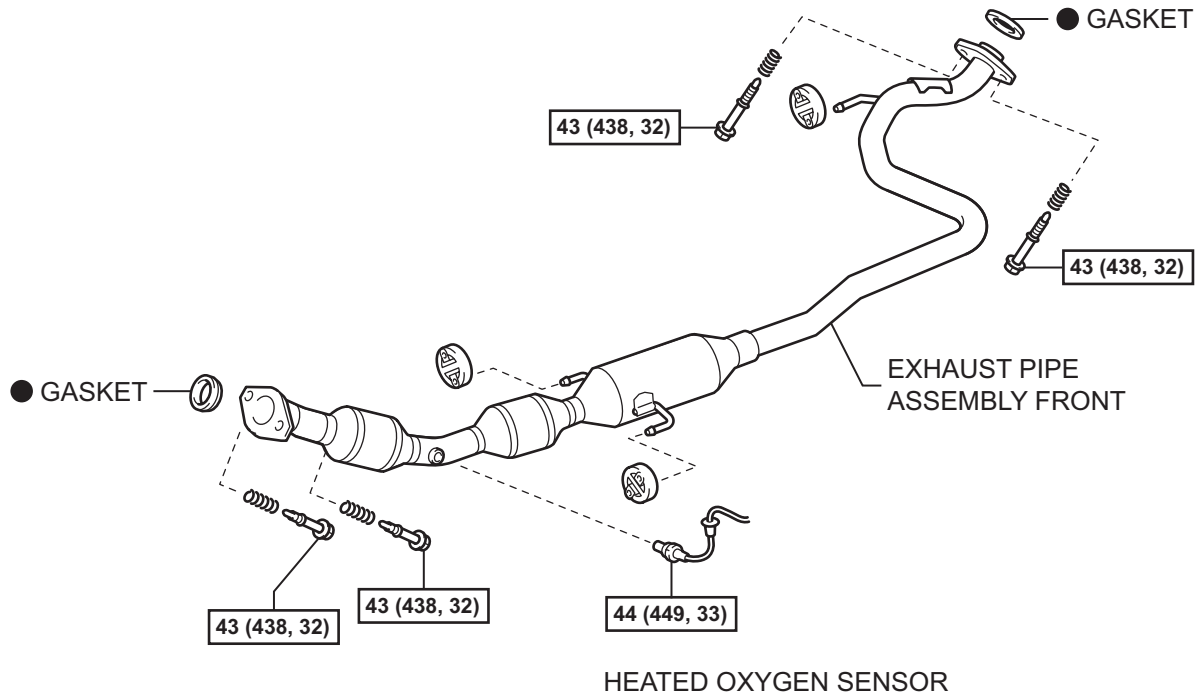

$N \cdot m$ (kgf \cdot cm, ft \cdot lbf) : Specified torque

 ● Non-reusable part

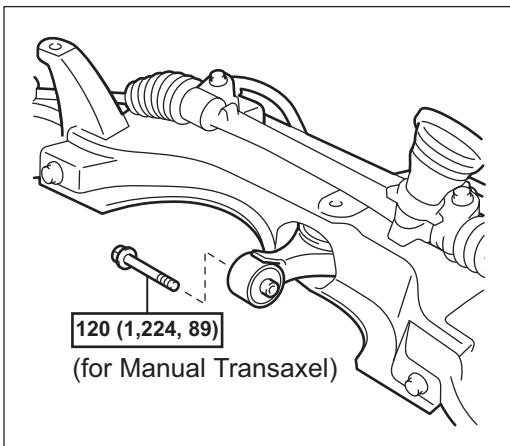
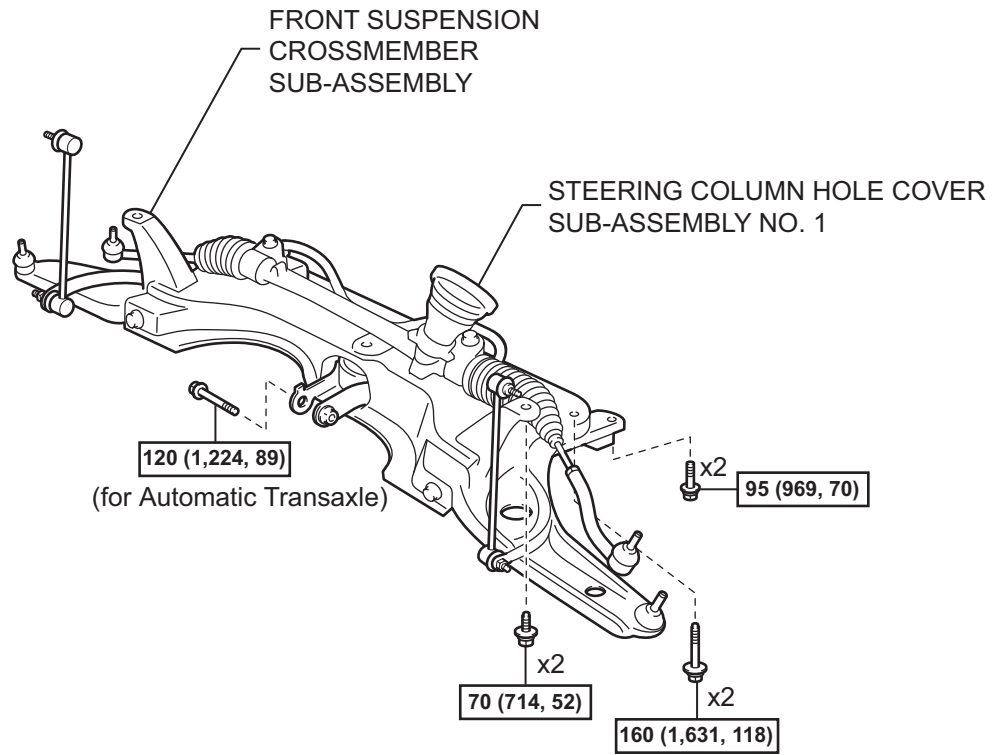

N*m (kgf*cm, ft.*lbf) : Specified torque



for Automatic Transaxle:

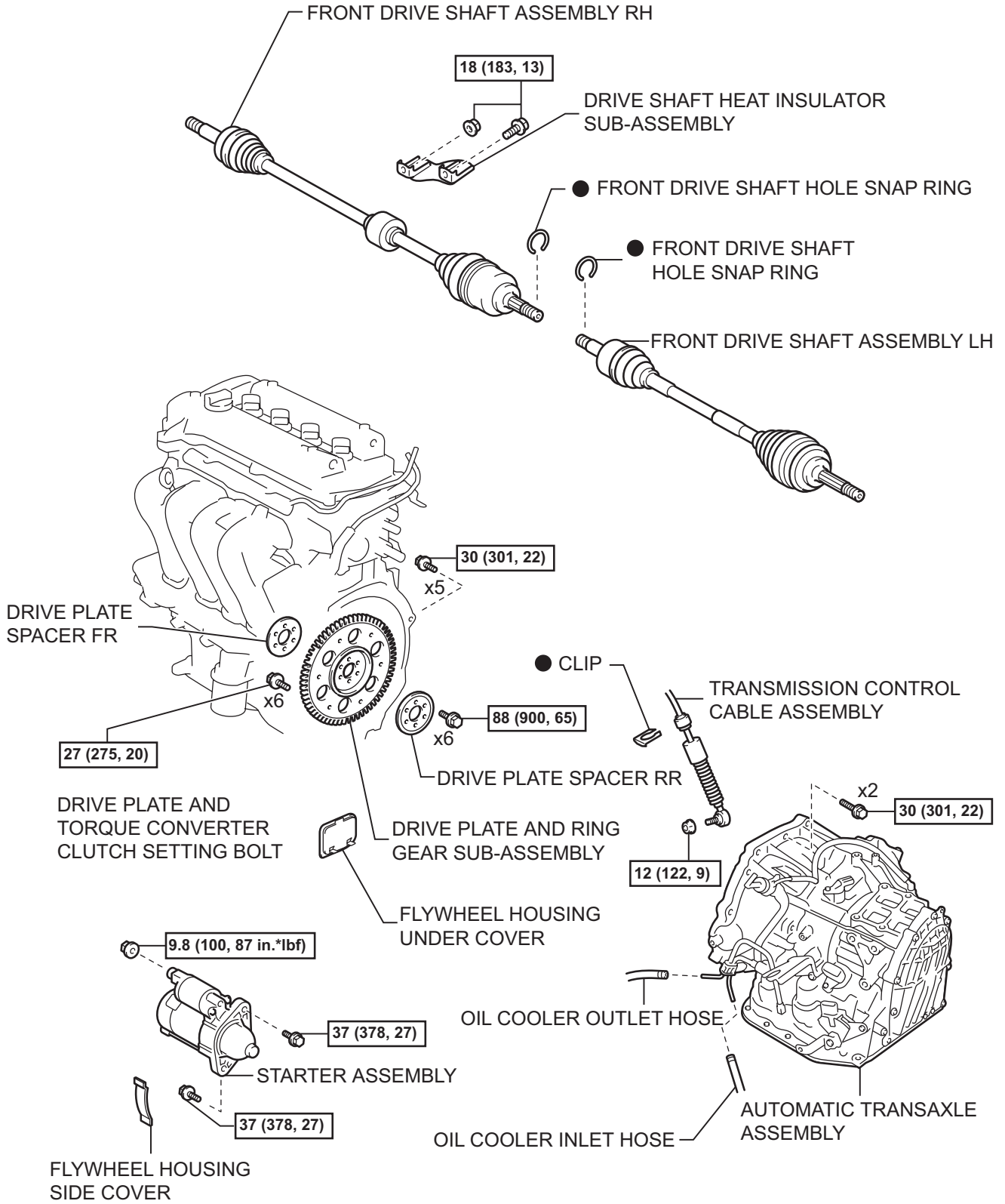

N*m (kgf*cm, ft.*lbf) : Specified torque ● Non-reusable part



EM

for Manual Transaxle:

EM

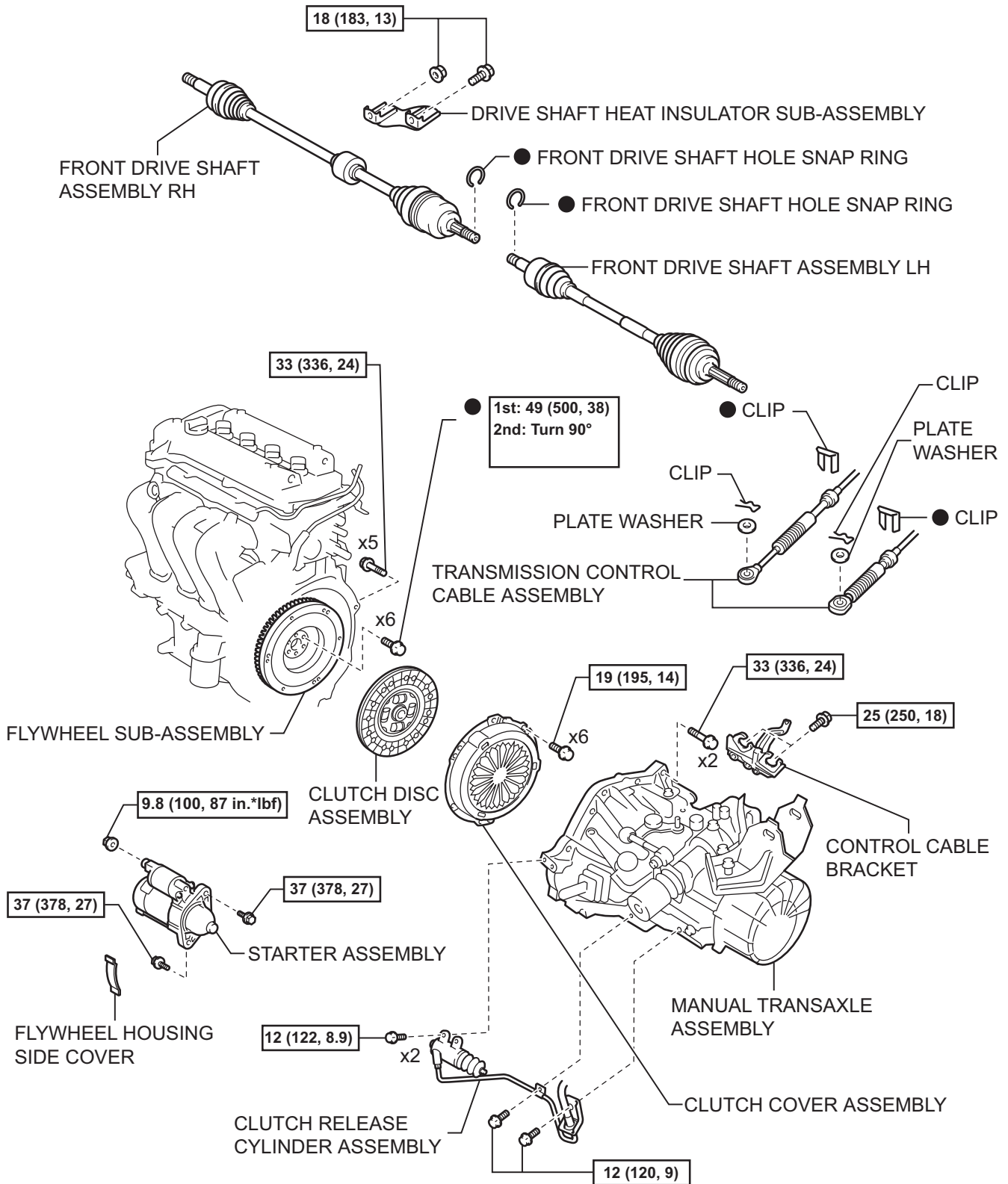

N*m (kgf*cm, ft*lbf) : Specified torque

● Non-reusable part



EM

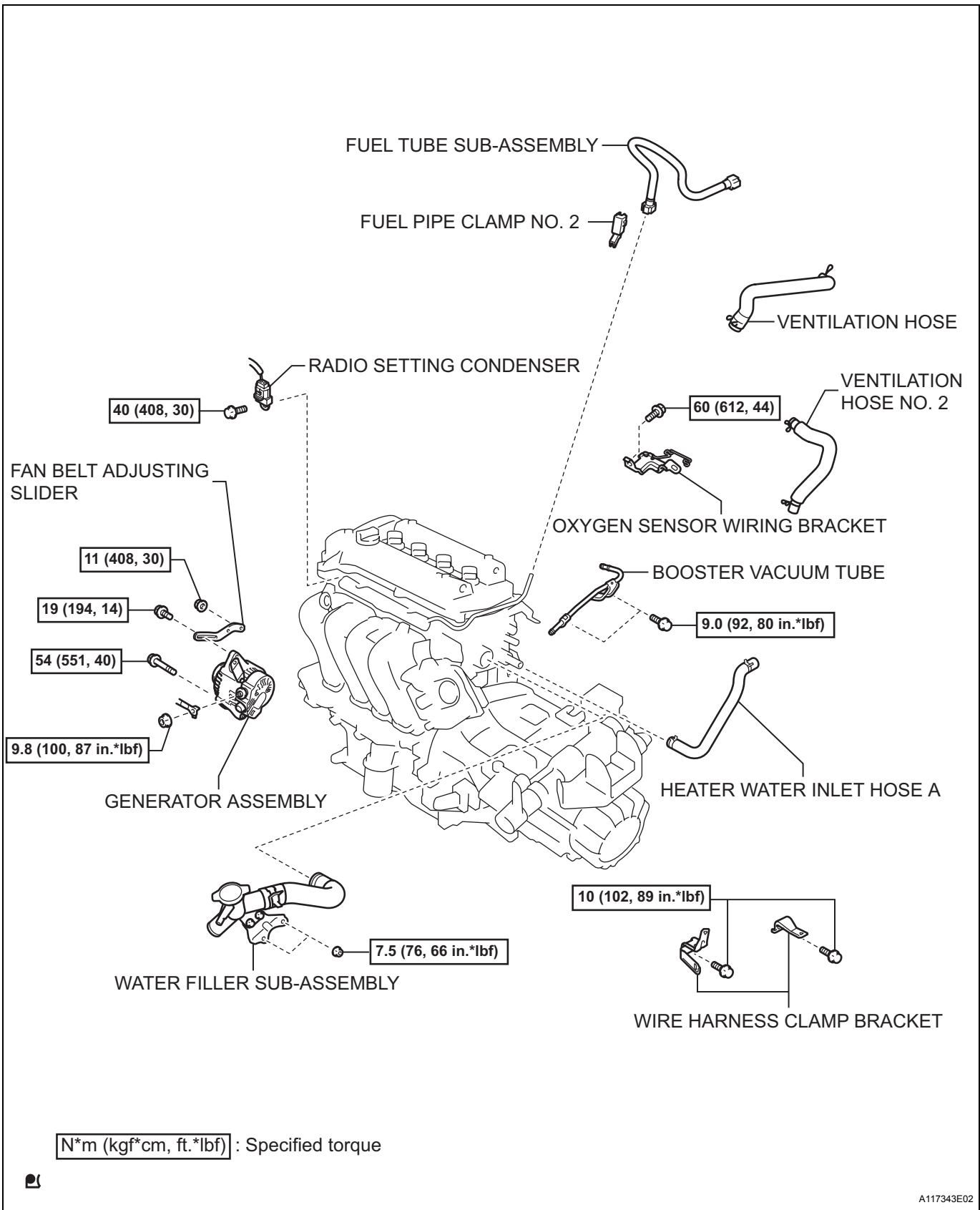

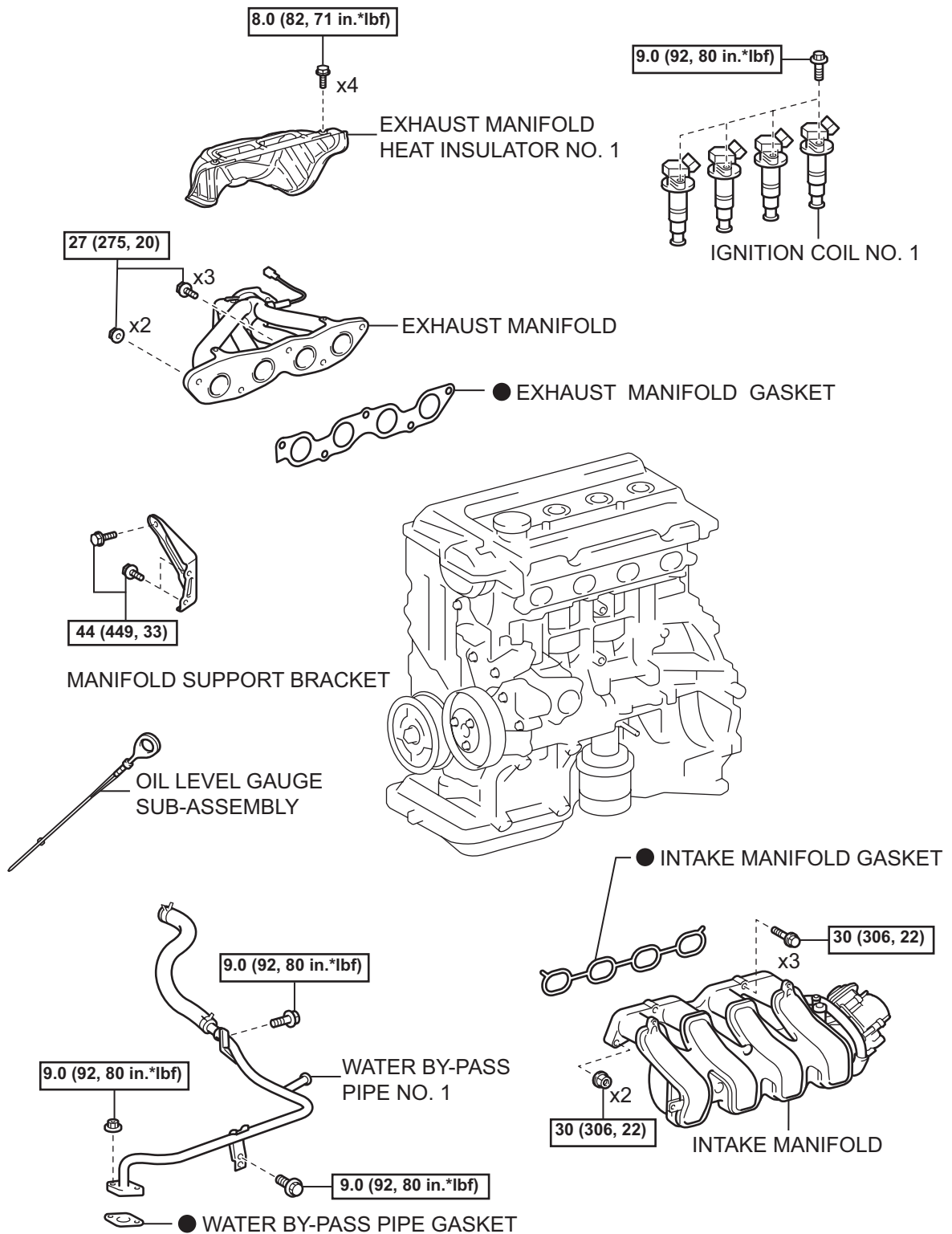

N*m (kgf*cm, ft.*lbf) : Specified torque ● Non-reusable part



REMOVAL

1. DISCHARGE FUEL SYSTEM PRESSURE
2. REMOVE BATTERY
 - (a) Disconnect the cable from the battery terminal.
 - (b) Loosen the nut and remove the battery clamp.
 - (c) Remove the battery.
3. REMOVE BATTERY TRAY
4. REMOVE FRONT WHEELS
5. REMOVE ENGINE UNDER COVER LH
6. REMOVE ENGINE UNDER COVER RH
7. DRAIN ENGINE COOLANT (See page [CO-8](#))
8. DRAIN AUTOMATIC TRANSAXLE FLUID (for Automatic Transaxle) (See page [AX-158](#))
9. DRAIN MANUAL TRANSAXLE OIL (for Manual Transaxle) (See page [MX-26](#))
10. REMOVE FRONT WIPER ARM HEAD CAP (See page [WW-9](#))
11. REMOVE FRONT WIPER ARM LH (See page [WW-9](#))
12. REMOVE FRONT WIPER ARM RH (See page [WW-9](#))
13. REMOVE HOOD TO COWL TOP SEAL (for Hatchback) (See page [WW-18](#))
14. REMOVE COWL TOP VENTILATOR LOUVER SUB-ASSEMBLY (for Hatchback) (See page [WW-18](#))
15. REMOVE COWL TOP VENTILATOR LOUVER LH (for Hatchback) (See page [WW-18](#))
16. REMOVE COWL SIDE VENTILATOR SUB-ASSEMBLY LH (for Sedan) (See page [WW-10](#))
17. REMOVE COWL SIDE VENTILATOR SUB-ASSEMBLY RH (for Sedan) (See page [WW-10](#))
18. REMOVE COWL TOP VENTILATOR LOUVER SUB-ASSEMBLY (for Sedan) (See page [WW-10](#))
19. REMOVE FRONT WIPER MOTOR AND LINK (See page [WW-19](#))
20. REMOVE COWL TO REGISTER DUCT SUB-ASSEMBLY NO. 2 (for Hatchback)
 - (a) Disengage the claw and remove cowl to register duct sub-assembly No. 2.

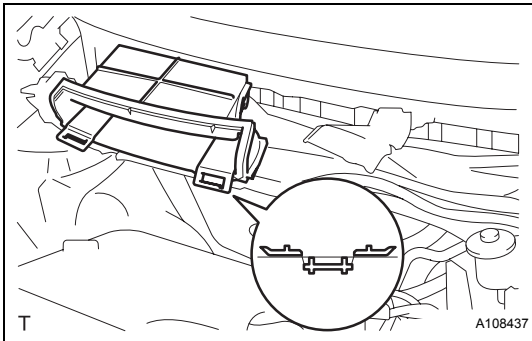

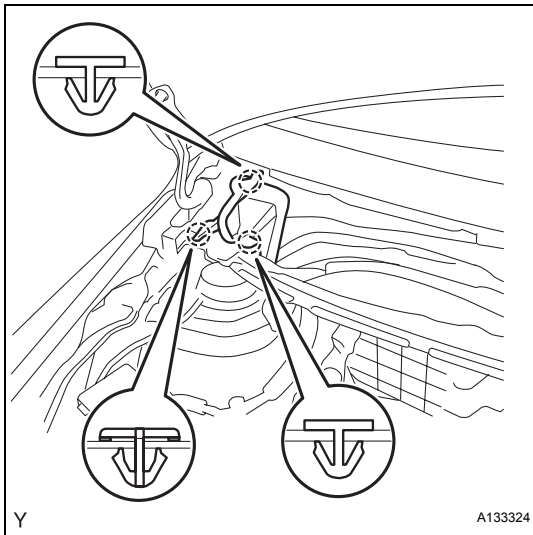

21. REMOVE FRONT AIR SHUTTER SEAL RH (for Sedan)

- (a) Disengage the 3 claws and remove the front air shutter seal RH.

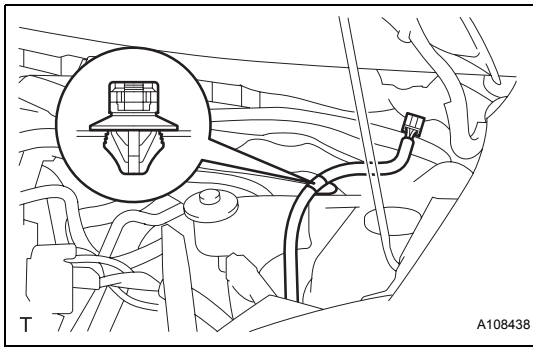

22. REMOVE COWL TOP PANEL OUTER (for Hatchback)

- (a) Disengage the wire harness clamp.

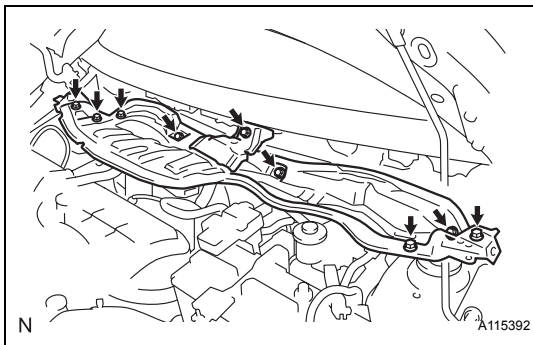

- (b) Remove the 9 bolts and remove the cowl top panel outer.

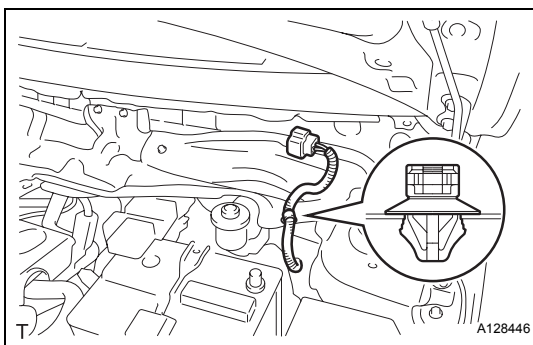

23. REMOVE COWL TOP PANEL OUTER (for Sedan)

- (a) Disengage the wire harness clamp.

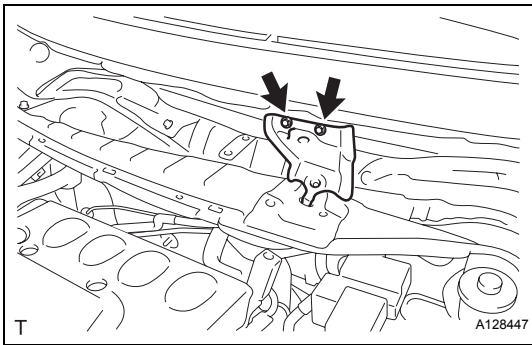

- (b) Remove the 2 bolts and remove the cowl top to cowl inner brace.

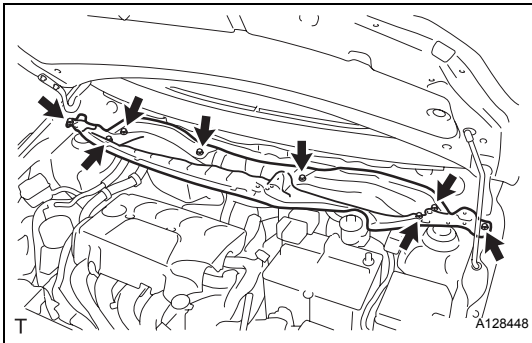

- (c) Remove the 8 bolts and remove the cowl top panel outer.

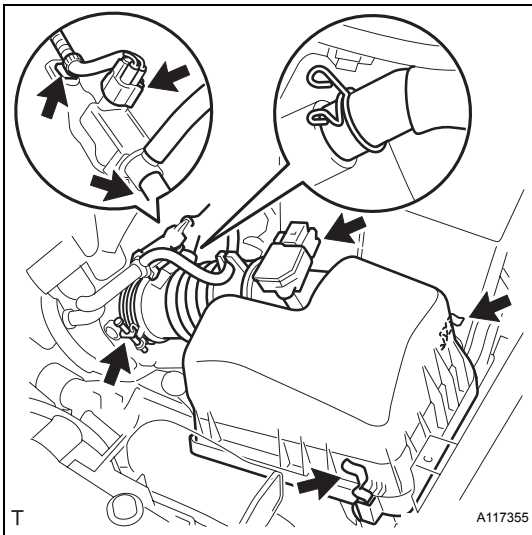

24. REMOVE AIR CLEANER ASSEMBLY

- (a) Separate the intake air flow meter connector and the wire harness clamp.
- (b) Separate the fuel vapor feed hose and fuel vapor feed hose No. 1 from the vacuum switching valve assembly.
- (c) Separate the vacuum switching valve connector and the wire harness clamp.
- (d) Separate the ventilation hose from the air cleaner hose.
- (e) Release the air cleaner cap sub-assembly with air cleaner hose No. 1.
- (f) Loosen the air cleaner hose clamp on the throttle body side and remove the air cleaner cap and the air cleaner hose.
- (g) Remove the air cleaner element.
- (h) Separate the wire harness clamp from the air cleaner case.
- (i) Remove the 2 bolts and remove the air cleaner case with air cleaner inlet No. 1.

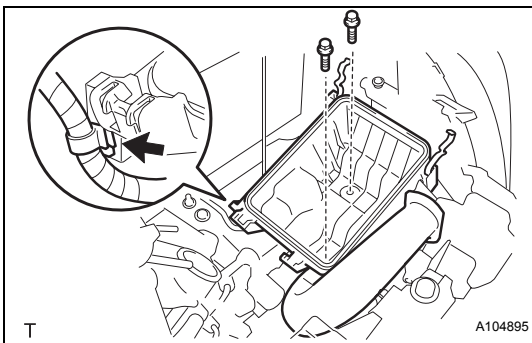

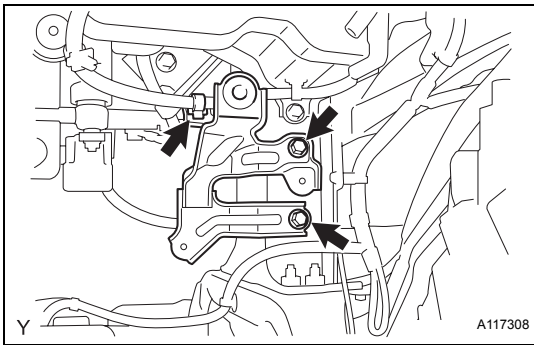
**25. REMOVE AIR CLEANER BRACKET**

- (a) Separate the wire harness clamp from the air cleaner bracket.
- (b) Remove the 2 bolts and remove the air cleaner bracket.

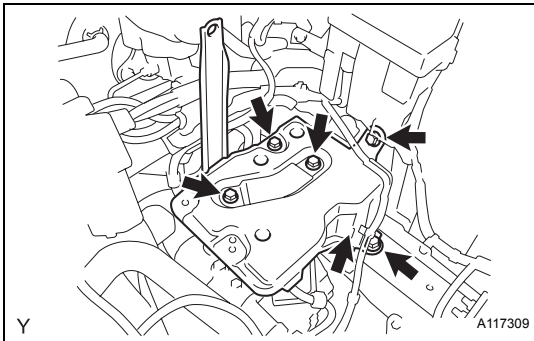
**26. REMOVE BATTERY CARRIER**

- (a) Separate the wire harness clamp from the battery carrier.
- (b) Remove the 5 bolts and remove the battery carrier.

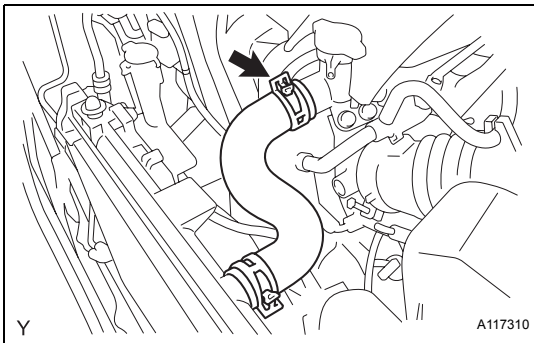
**27. DISCONNECT RADIATOR HOSE NO. 3**

- (a) Disconnect radiator hose No. 3 from the water filler.

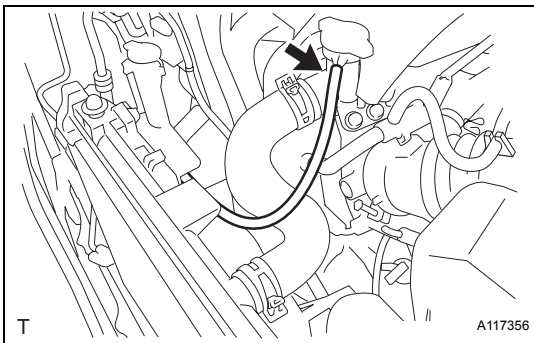
**28. DISCONNECT RADIATOR RESERVOIR TANK HOSE**

- (a) Disconnect the radiator reservoir tank hose from the water filler.

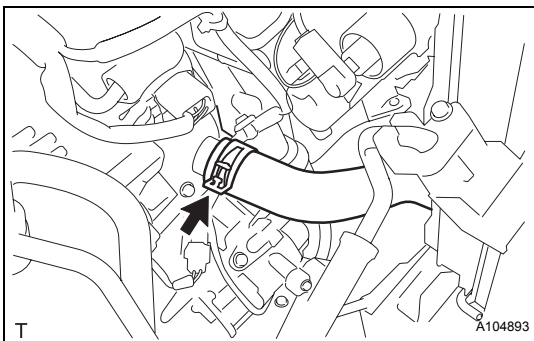
**29. DISCONNECT RADIATOR HOSE NO. 2**

- (a) Disconnect radiator hose No. 2 from the water inlet.

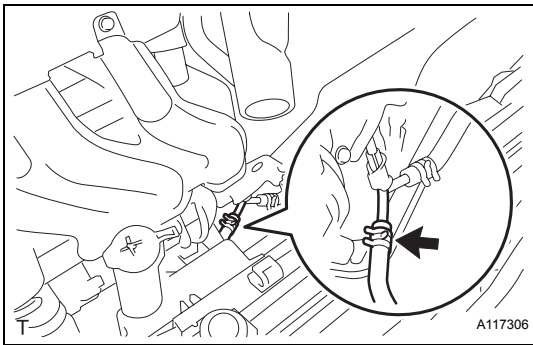

30. DISCONNECT OIL COOLER OUTLET HOSE (for Automatic Transaxle)

- (a) Loosen the clip and disconnect the oil cooler outlet hose.

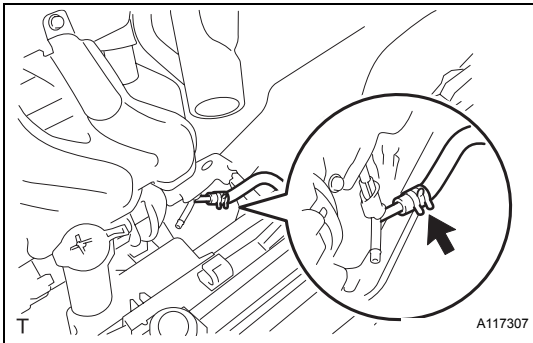

31. DISCONNECT OIL COOLER INLET HOSE (for Automatic Transaxle)

- (a) Loosen the clip and disconnect the oil cooler inlet hose.

32. REMOVE CYLINDER HEAD COVER NO. 2 (See page IG-9)

33. SEPARATE TRANSMISSION CONTROL CABLE ASSEMBLY (for Automatic Transaxle) (See page AX-106)

34. SEPARATE TRANSMISSION CONTROL CABLE ASSEMBLY (for Manual Transaxle) (See page MX-27)

35. DISCONNECT UNION TO CHECK VALVE HOSE

- (a) Disconnect the union to check valve hose from the booster vacuum tube.

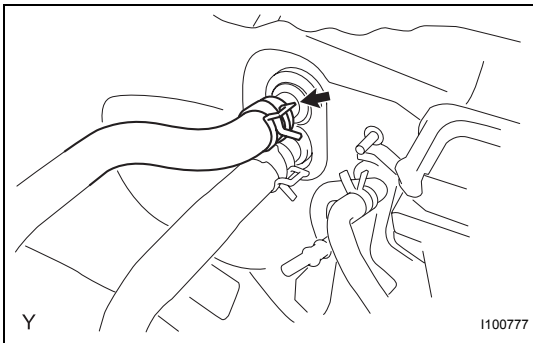

36. DISCONNECT HEATER WATER OUTLET HOSE A (FROM HEATER UNIT)

- (a) Disconnect heater water outlet hose A from the heater unit.

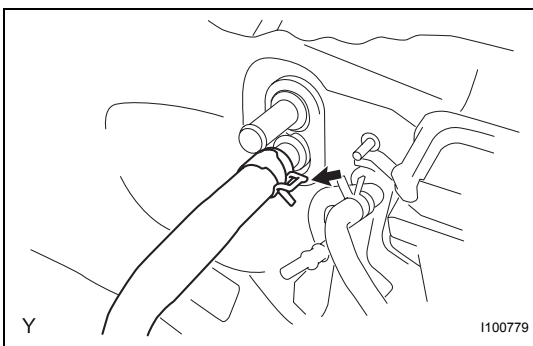

37. DISCONNECT HEATER WATER INLET HOSE A

- (a) Disconnect heater water inlet hose A from the heater unit.

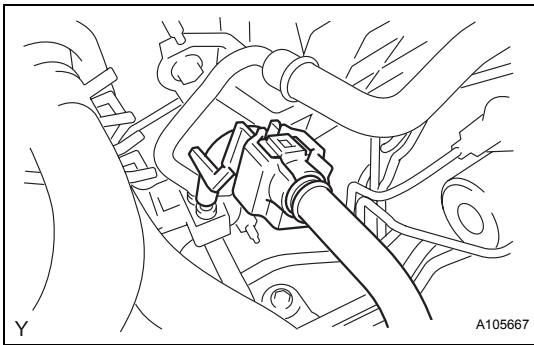
**38. DISCONNECT FUEL TUBE SUB-ASSEMBLY**

- (a) Remove fuel pipe clamp No. 1.

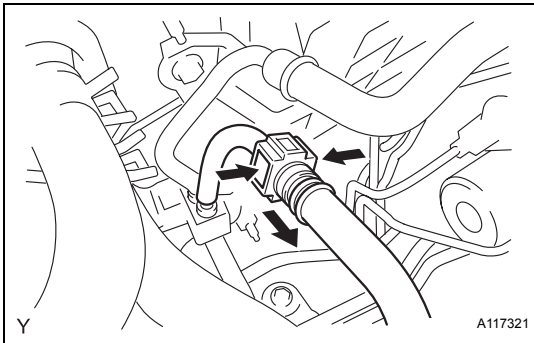

- (b) Pinch the retainer as illustrated, then pull the fuel tube connector out of the pipe.

NOTICE:

- Remove any dirt and foreign matter from the fuel tube connector before performing this work.
- Do not allow any scratches or foreign matter on the parts when disconnecting, as the fuel tube connector has the O-rings that seal the pipe.
- Perform this work by hand. Do not use any tools.
- Do not forcibly bend, twist or turn the nylon tube.
- Protect the disconnected parts by covering them with vinyl bags after disconnecting the fuel tube.
- If the fuel tube connector and pipe are stuck, push and pull to release them.

39. REMOVE FAN AND GENERATOR V BELT (See page [EM-7](#))**40. SEPARATE WITH PULLEY COMPRESSOR ASSEMBLY (w/ Air Conditioning System)**

- (a) Disconnect the connector.
 (b) Remove the 4 bolts and separate the with pulley compressor assembly.

HINT:

Remove the compressor assembly together with the low and high pressure hoses, then suspend them from the body with a piece of rope.

41. SEPARATE CLUTCH RELEASE CYLINDER ASSEMBLY (for Manual Transaxle) (See page [MX-27](#))

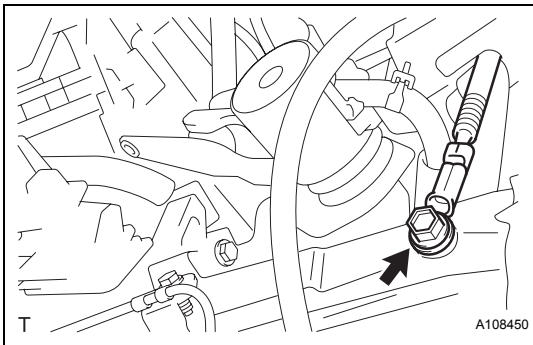
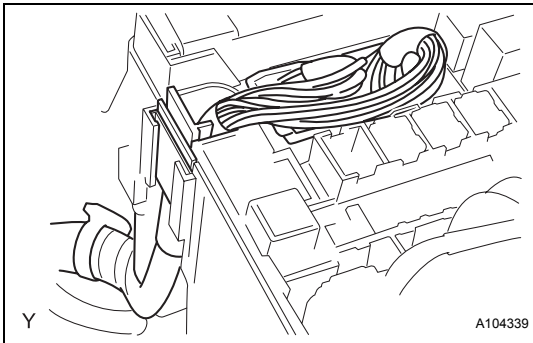
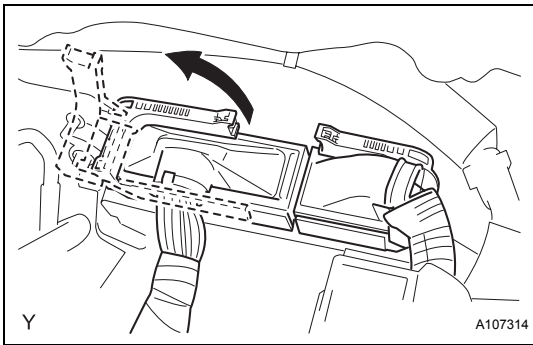

42. DISCONNECT ENGINE WIRE

- (a) Pull up the lever and disconnect the connector of the engine control computer.
- (b) Remove the 2 connectors and the clamp from the engine room junction block and disconnect the wire harness.
- (c) Remove the bolt and separate the earth wire of the engine room wire harness.
- (d) Disconnect all the wire harnesses and connectors. Make sure that no wire harness is connected between the body and engine.

43. REMOVE COLUMN HOLE COVER SILENCER SHEET (See page [PS-74](#))

44. SEPARATE STEERING SLIDING YOKE SUB-ASSEMBLY (See page [PS-74](#))

45. REMOVE STEERING COLUMN HOLE COVER SUB-ASSEMBLY NO. 1 (See page [PS-75](#))

46. REMOVE SHIFT LEVER KNOB SUB-ASSEMBLY (for Manual Transaxle)

47. REMOVE SHIFTING HOLE COVER SUB-ASSEMBLY (for Manual Transaxle) (See page [PB-6](#))

48. REMOVE CONSOLE BOX REAR COVER (for Hatchback) (See page [PB-6](#))

49. REMOVE INSTRUMENT PANEL FINISH PANEL LOWER CENTER (for Sedan) (See page [ME-138](#))

50. REMOVE INSTRUMENT PANEL FINISH PANEL END LH (for Sedan) (See page [ME-138](#))

51. REMOVE INSTRUMENT PAD LOWER LH (for Sedan) (See page [IP-44](#))

52. REMOVE UPPER CONSOLE PANEL SUB-ASSEMBLY (for Sedan) (See page [IP-84](#))

53. REMOVE CONSOLE UPPER REAR PANEL SUB-ASSEMBLY (for Sedan) (See page [IP-84](#))

54. REMOVE CONSOLE BOX CARPET (for Sedan) (See page [PB-7](#))
55. REMOVE REAR CONSOLE BOX ASSEMBLY (See page [PB-8](#))
56. REMOVE HEATED OXYGEN SENSOR (See page [EC-22](#))
57. REMOVE EXHAUST PIPE ASSEMBLY FRONT (See page [EX-5](#))
58. REMOVE FRONT AXLE HUB LH NUT (See page [DS-3](#))
59. REMOVE FRONT AXLE HUB RH NUT (See page [AX-159](#))
60. SEPARATE SPEED SENSOR FRONT LH (w/ ABS) (See page [DS-3](#))
61. SEPARATE SPEED SENSOR FRONT RH (w/ ABS) (See page [AX-159](#))
62. SEPARATE TIE ROD END SUB-ASSEMBLY LH (See page [DS-3](#))
63. SEPARATE TIE ROD END SUB-ASSEMBLY RH (See page [AX-160](#))
64. SEPARATE FRONT STABILIZER LINK ASSEMBLY LH (See page [DS-4](#))
65. SEPARATE FRONT STABILIZER LINK ASSEMBLY RH (See page [AX-160](#))
66. SEPARATE FRONT SUSPENSION ARM SUB-ASSEMBLY LOWER NO. 1 LH (See page [DS-4](#))
67. SEPARATE FRONT SUSPENSION ARM SUB-ASSEMBLY LOWER NO. 1 RH (See page [AX-160](#))
68. SEPARATE FRONT AXLE ASSEMBLY LH (See page [DS-4](#))
69. SEPARATE FRONT AXLE ASSEMBLY RH (See page [MX-29](#))
70. REMOVE FRONT DRIVE SHAFT ASSEMBLY LH (See page [DS-5](#))
71. REMOVE FRONT DRIVE SHAFT ASSEMBLY RH (See page [DS-5](#))
72. REMOVE FLYWHEEL HOUSING UNDER COVER (for Automatic Transaxle)

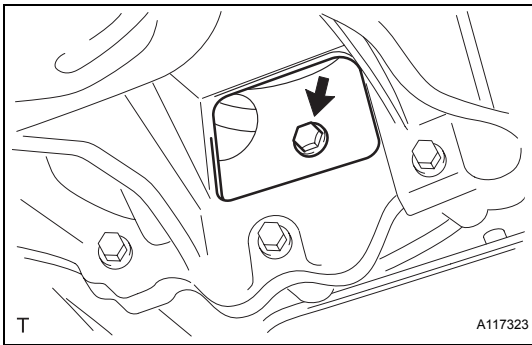

73. REMOVE DRIVE PLATE AND TORQUE CONVERTER CLUTCH SETTING BOLT (for Automatic Transaxle)

- (a) Remove the 6 torque converter set bolts.

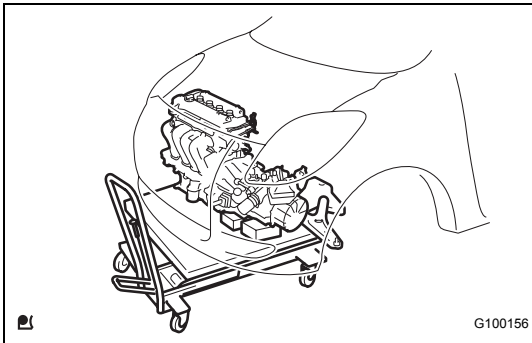

74. REMOVE ENGINE ASSEMBLY WITH TRANSAXLE

- (a) Set the engine lifter.

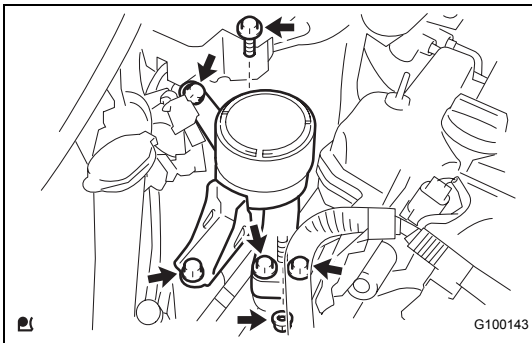

- (b) Remove the 5 bolts and the nut and remove the engine mounting insulator RH.

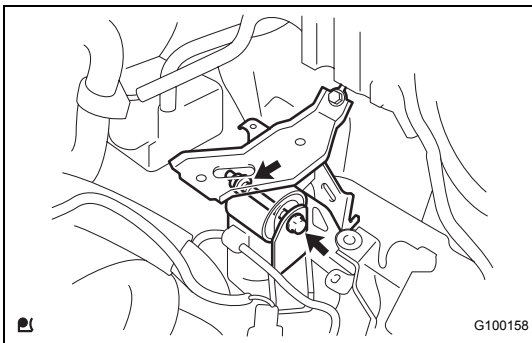

- (c) Remove the through bolt and the nut and separate the engine mounting insulator LH.

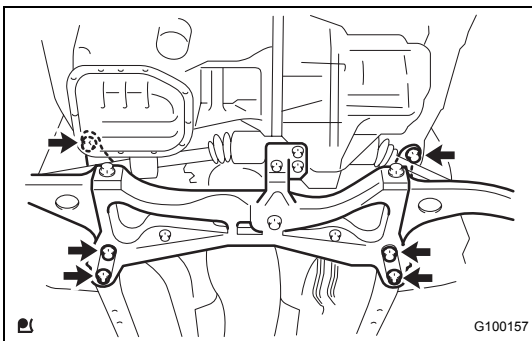

75. REMOVE FRONT SUSPENSION CROSSMEMBER SUB-ASSEMBLY

- (a) Remove the bolt and remove the radio setting condenser.
- (b) Remove the bolt and remove the oxygen sensor wiring bracket.

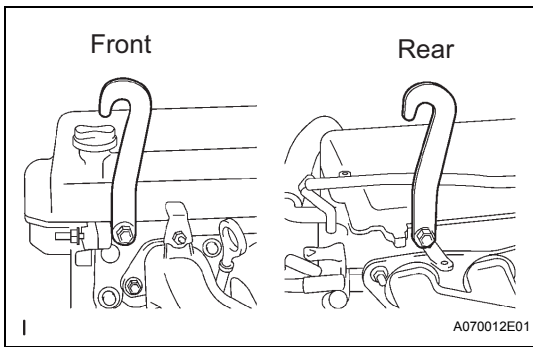

- (c) Install the engine hangers with the bolts, as shown in the illustration.

Torque: 40 N*m (408 kgf*cm, 30 ft.*lbf)

Part No.:

12281-21010 for engine hanger

91642-81025 for bolt

- (d) Using an engine sling device and a chain block, suspend the engine assembly with transaxle and front suspension crossmember.
- (e) Remove the through bolt from the engine moving control rod and remove the front suspension crossmember.

76. REMOVE VENTILATION HOSE

- (a) Loosen the 2 clips and remove the ventilation hose.

77. REMOVE VENTILATION HOSE NO. 2

- (a) Loosen the clips and remove ventilation hose No. 2.

78. REMOVE FUEL TUBE SUB-ASSEMBLY

- (a) Disengage the claw and remove fuel pipe clamp No. 2.

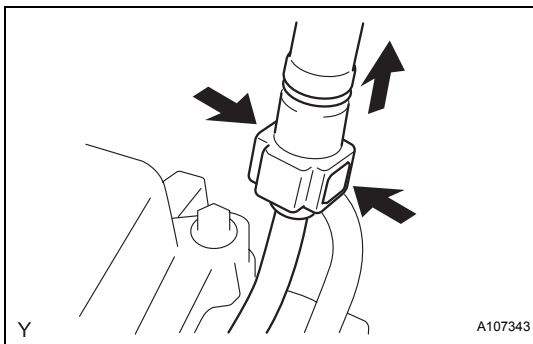
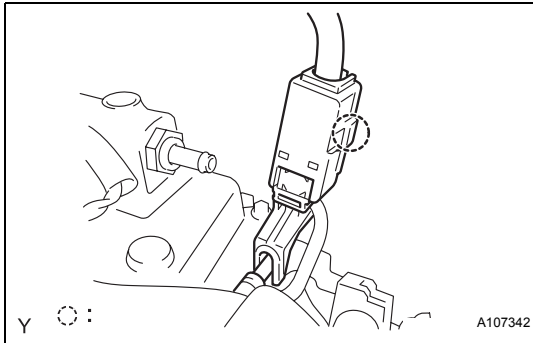

- (b) Pinch the fuel tube connector retainer from both sides, disconnect the fuel tube connector and separate the fuel tube from the pipe.

NOTICE:

- Remove any dirt and foreign matter from the fuel tube connector before performing this work.
- Do not allow any scratches or foreign matter on the parts when disconnecting, as the fuel tube connector has the O-rings that seal the pipe.
- Perform this work by hand. Do not use any tools.
- Do not forcibly bend, twist or turn the nylon tube.
- Protect the disconnected parts by covering them with vinyl bags after disconnecting the fuel tube.
- If the fuel tube connector and pipe are stuck, push and pull to release them.

79. REMOVE WATER FILLER SUB-ASSEMBLY

- (a) Disconnect radiator hose No. 1 from the cylinder head.
- (b) Remove the 2 nuts and remove the water filler sub-assembly.

EM

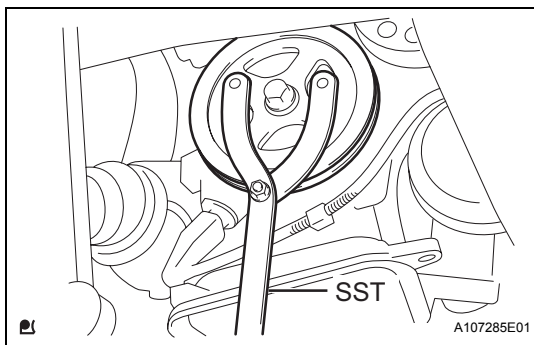
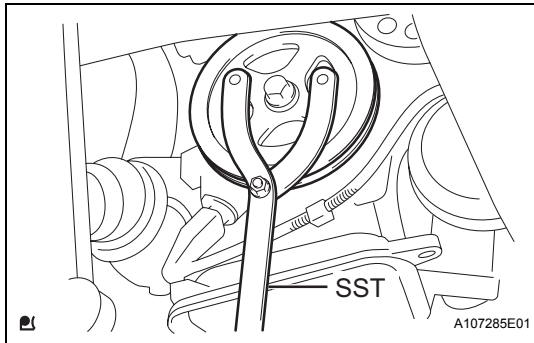
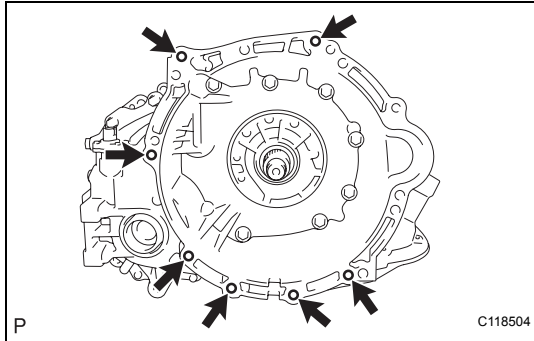

80. **REMOVE HEATER WATER INLET HOSE A**
 - (a) Disconnect heater water inlet hose A from the cylinder head.
81. **REMOVE FLYWHEEL HOUSING SIDE COVER** (See page [ST-9](#))
82. **REMOVE STARTER ASSEMBLY** (See page [ST-9](#))
83. **REMOVE AUTOMATIC TRANSAXLE ASSEMBLY** (for Automatic Transaxle)
 - (a) Remove the 7 bolts and remove the automatic transaxle with torque converter.
84. **REMOVE DRIVE PLATE AND RING GEAR SUB-ASSEMBLY** (for Automatic Transaxle)
 - (a) Hold the crankshaft with SST.
SST 09960-10010 (09962-01000, 09963-01000)
 - (b) Remove the 6 bolts, drive plate spacer FR, drive plate and ring gear sub-assembly and drive plate spacer RR.
85. **REMOVE CONTROL CABLE BRACKET** (for Manual Transaxle) (See page [MX-28](#))
86. **REMOVE MANUAL TRANSAXLE ASSEMBLY** (for Manual Transaxle) (See page [MX-30](#))
87. **REMOVE CLUTCH COVER ASSEMBLY** (for Manual Transaxle) (See page [CL-15](#))
88. **REMOVE CLUTCH DISC ASSEMBLY** (for Manual Transaxle)
89. **REMOVE FLYWHEEL SUB-ASSEMBLY** (for Manual Transaxle)
 - (a) Hold the crankshaft with SST.
SST 09960-10010 (09962-01000, 09963-01000)
 - (b) Remove the 6 bolts and flywheel.
90. **REMOVE OIL LEVEL GAUGE SUB-ASSEMBLY**
91. **REMOVE IGNITION COIL NO. 1**
 - (a) Disconnect the connectors of the ignition coils.
 - (b) Remove the bolt and remove all the ignition coils.
92. **REMOVE GENERATOR ASSEMBLY** (See page [CH-10](#))

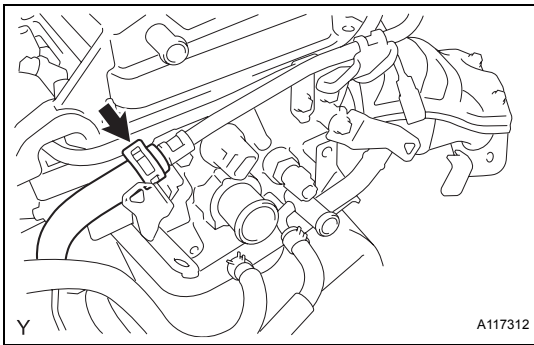
**93. REMOVE INTAKE MANIFOLD**

- (a) Disconnect the union to connector tube hose from the booster vacuum tube.
- (b) Disconnect the engine wire from the intake manifold.

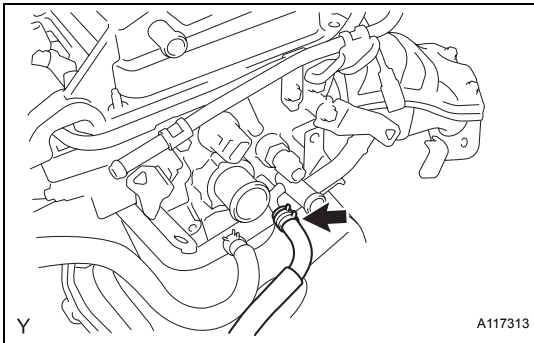

- (c) Disconnect the water by-pass hose from the cylinder head.

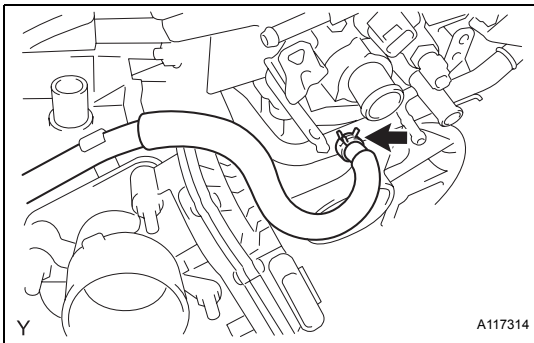

- (d) Disconnect the water by-pass hose from water bypass pipe No. 1.
- (e) Disconnect the throttle with motor body assembly connector.

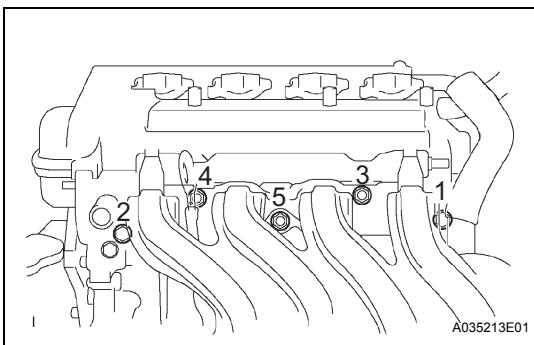

- (f) Remove the 3 bolts and 2 nuts in the order shown in the illustration and remove the intake manifold.
- (g) Remove the gasket from the intake manifold.

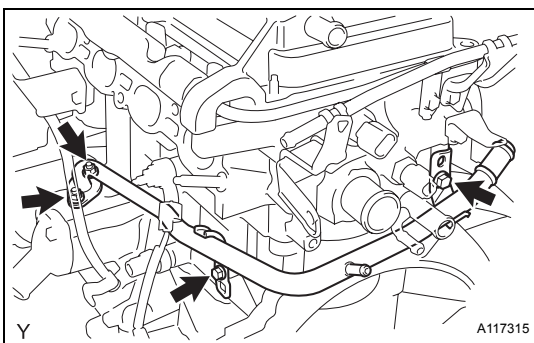
**94. REMOVE WATER BY-PASS PIPE NO. 1**

- (a) Remove the 2 bolts and 2 nuts and remove water by-pass pipe No. 1.

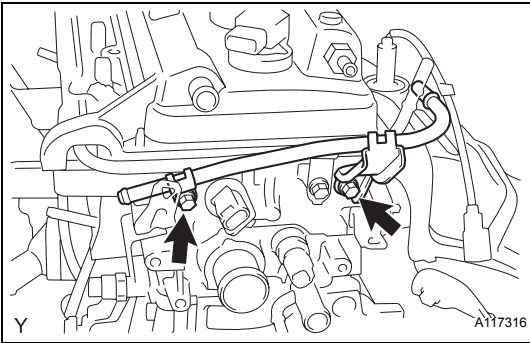
**95. REMOVE BOOSTER VACUUM TUBE**

- (a) Remove the 2 bolts and remove the booster vacuum tube.

96. REMOVE ENGINE WIRE

- (a) Disconnect all the sensor connectors and wire harness clamps from the engine assembly and remove the engine wire harness.

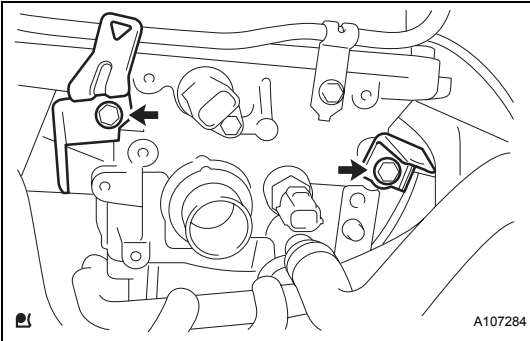
**97. REMOVE WIRE HARNESS CLAMP BRACKET**

- (a) Remove the 2 bolts and remove the 2 wire harness clamp brackets.

98. REMOVE EXHAUST MANIFOLD HEAT INSULATOR NO. 1

- (a) Remove the 4 bolts and remove the exhaust manifold heat insulator.

99. REMOVE MANIFOLD SUPPORT BRACKET

- (a) Remove the 3 bolts and remove the manifold support bracket.

100. REMOVE EXHAUST MANIFOLD

- (a) Remove the 3 bolts and 2 nuts and remove the exhaust manifold.

101. REMOVE DRIVE SHAFT HEAT INSULATOR SUB-ASSEMBLY

- (a) Remove the bolt and nut and remove the drive shaft heat insulator.

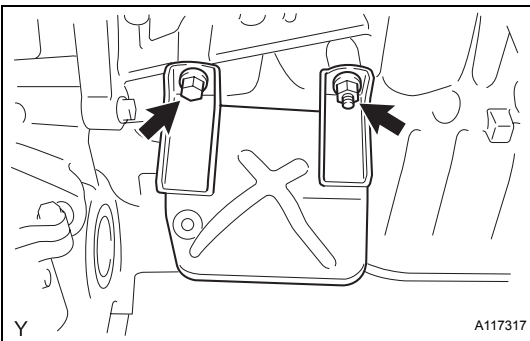
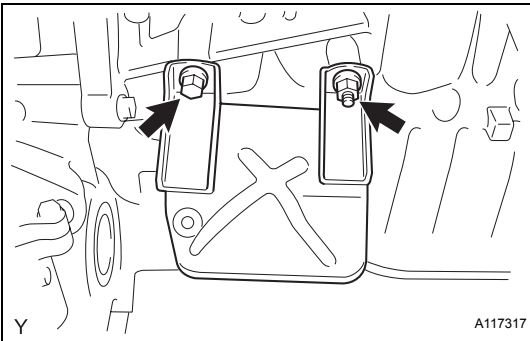
**INSTALLATION****1. INSTALL DRIVE SHAFT HEAT INSULATOR SUB-ASSEMBLY**

- (a) Install the drive shaft heat insulator sub-assembly with the bolt and nut.

Torque: 18 N*m (183 kgf*cm, 13 ft.*lbf)

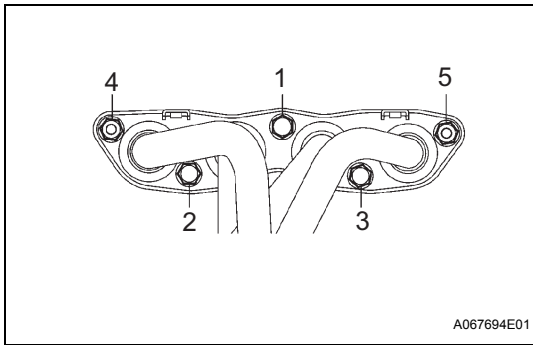

2. INSTALL EXHAUST MANIFOLD

- (a) Tighten the exhaust manifold nuts and bolts, in the order shown in the illustration, through a new gasket.

Torque: 27 N*m (275 kgf*cm, 20 ft.*lbf)

3. INSTALL MANIFOLD SUPPORT BRACKET

- (a) Install the manifold bracket with the 3 bolts.

Torque: 44 N*m (449 kgf*cm, 33 ft.*lbf)

4. INSTALL EXHAUST MANIFOLD HEAT INSULATOR NO.1

- (a) Install the exhaust manifold insulator with the 4 bolts.

Torque: 8.0 N*m (82 kgf*cm, 71 in.*lbf)

5. INSTALL WIRE HARNESS CLAMP BRACKET

- (a) Install the 2 wire harness clamp brackets with the 2 bolts.

Torque: 10 N*m (102 kgf*cm, 89 in.*lbf)

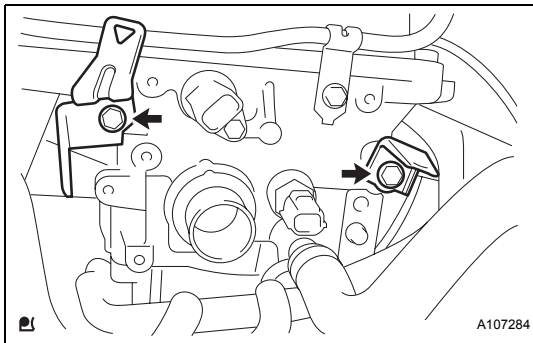

6. INSTALL ENGINE WIRE

- (a) Connect all the sensor connectors and wire harness clamps to the engine assembly and install the engine wire harness.

7. INSTALL BOOSTER VACUUM TUBE

- (a) Install the booster vacuum tube with the 2 bolts.

Torque: 9.0 N*m (92 kgf*cm, 80 in.*lbf)

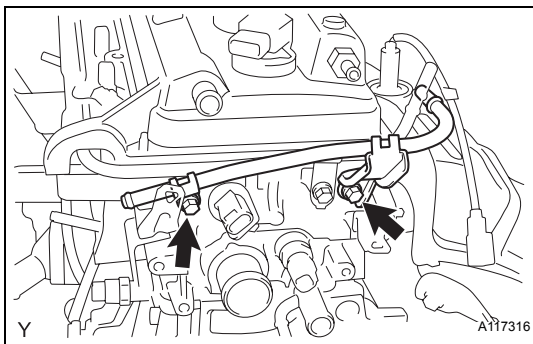

8. INSTALL WATER BY-PASS PIPE NO. 1

- (a) Install water by-pass pipe No. 1 through a new gasket with the 2 bolts and 2 nuts.

Torque: 9.0 N*m (92 kgf*cm, 80 in.*lbf)

9. INSTALL INTAKE MANIFOLD

- (a) Install a new gasket onto the intake manifold.

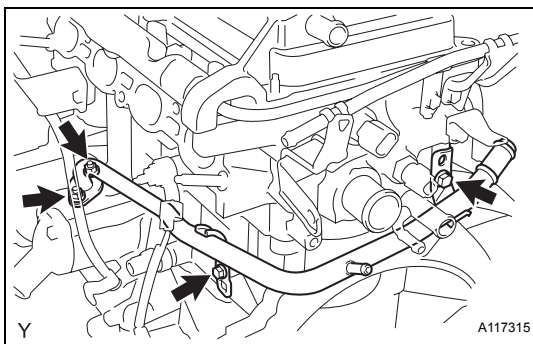

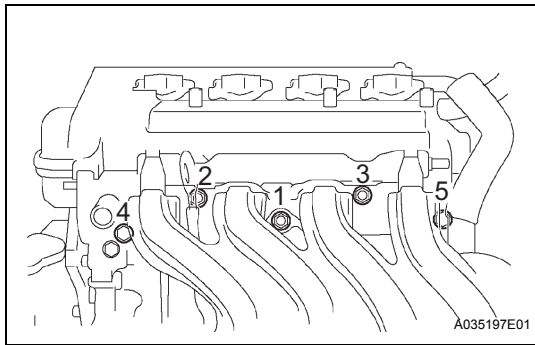

- (b) Provisionally tighten the intake manifold nuts and bolts in the order shown in the illustration, and then tighten them to the specified torque.
Torque: 30 N*m (306 kgf*cm, 22 ft.*lbf)
- (c) Connect the engine wire to the intake manifold.

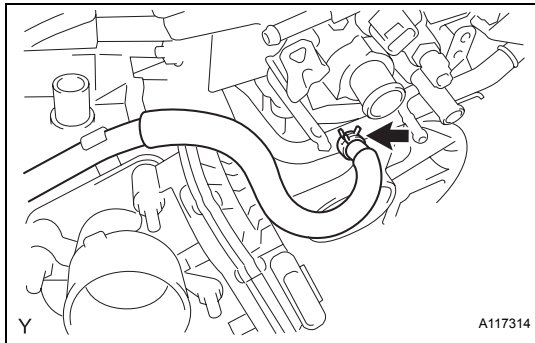

- (d) Connect the water by-pass hose to water bypass pipe No. 1.

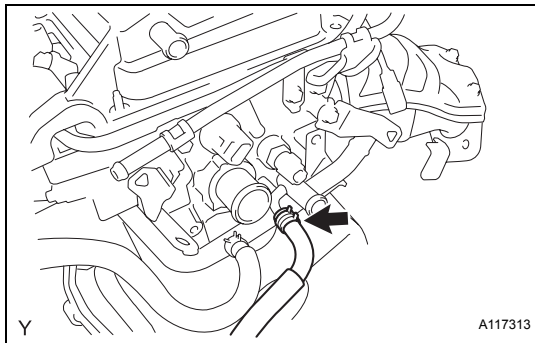

- (e) Connect the water by-pass hose to the cylinder head.
- (f) Connect the union to connector tube hose to the booster vacuum tube.
- (g) Connect the throttle with motor body assembly connector.

10. INSTALL OIL LEVEL GAUGE SUB-ASSEMBLY

11. INSTALL GENERATOR ASSEMBLY (See page [CH-17](#))

12. INSTALL IGNITION COIL NO.1 (See page [IG-9](#))

13. INSTALL DRIVE PLATE AND RING GEAR SUB-ASSEMBLY (for Automatic Transaxle)

- (a) Hold the crankshaft with SST.
SST 09960-10010 (09962-01000, 09963-01000)
- (b) Clean the 6 bolts and their holes.

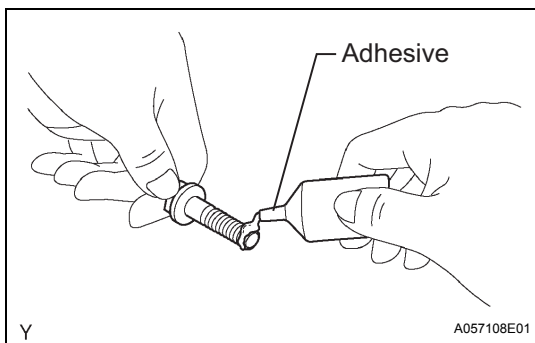
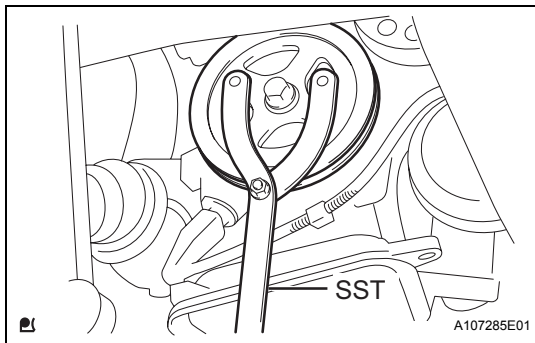

- (c) Apply adhesive to the end 2 or 3 threads of the bolts.
Adhesive:
Part No. 08833-0070, three bond 1324 or the equivalent.
- (d) Install the drive plate spacer RR, drive plate and ring gear sub-assembly and drive plate spacer FR.

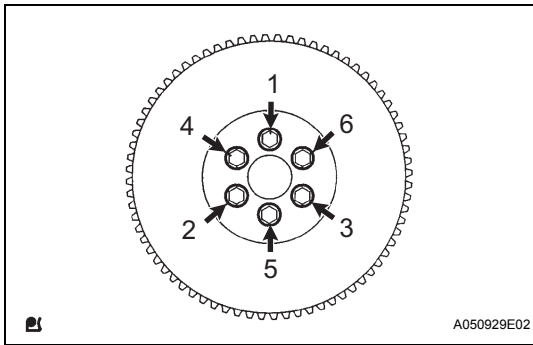

- (e) Install and uniformly tighten the 6 bolts in several steps, in the sequence shown in the illustration.

Torque: 88 N*m (900 kgf*cm, 65 ft.*lbf)

NOTICE:

Do not start the engine for at least 1 hour after performing the installation.

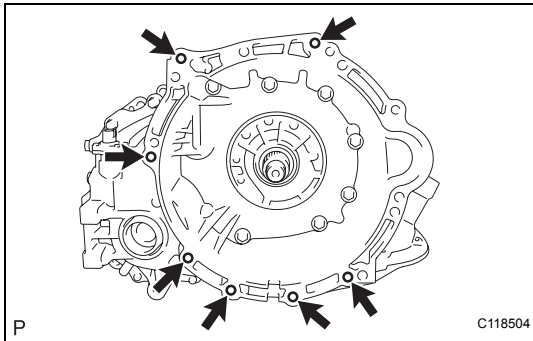

14. INSTALL AUTOMATIC TRANSAXLE ASSEMBLY (for Automatic Transaxle)

- (a) Make sure that the knock pin is installed on the engine side.
 (b) Install the automatic transaxle with torque converter with the 7 bolts.

Torque: 30 N*m (301 kgf*cm, 22 ft.*lbf)

CAUTION:

Make sure that the torque converter rotates.

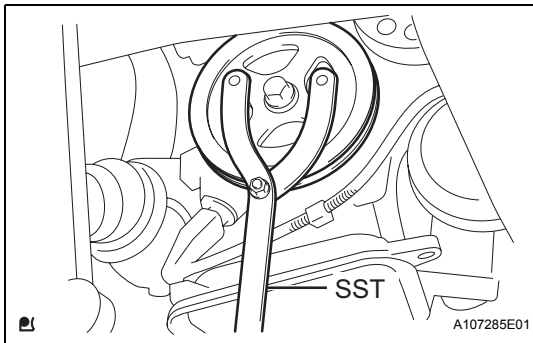

15. INSTALL FLYWHEEL SUB-ASSEMBLY (for Manual Transaxle)

- (a) Hold the crankshaft with SST.
SST 09960-10010 (09962-01000, 09963-01000)
 (b) Clean the 6 bolts and their holes.

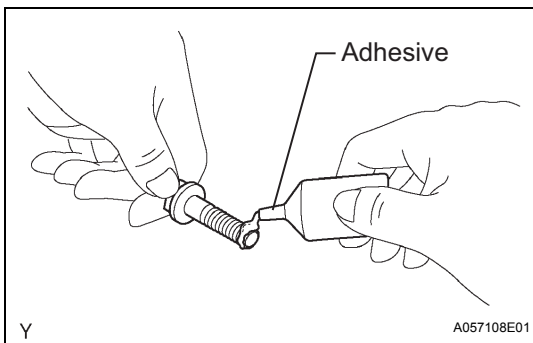

- (c) Apply adhesive to the end 2 or 3 threads of new bolts.

Adhesive:

Part No. 08833-0070, three bond 1324 or the equivalent.

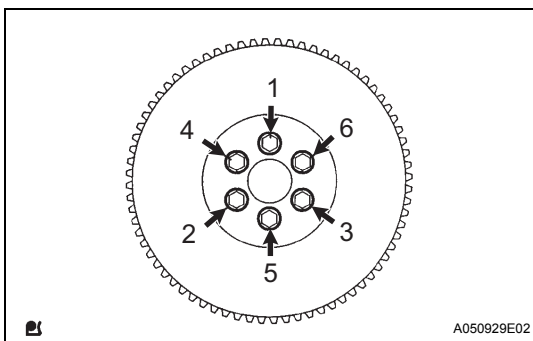

- (d) Install the flywheel with the 6 bolts in the order shown in the illustration.

Torque: 49 N*m (500 kgf*cm, 38 ft.*lbf)

- (e) Mark a paint mark on each bolt head on the engine upper side.

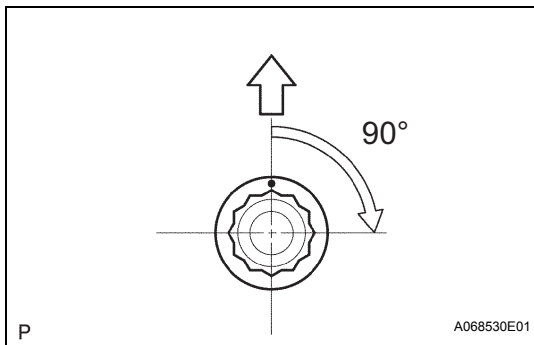

- (f) Tighten the bolts 90° in the sequence shown in the illustration.

NOTICE:

Do not start the engine for at least 1 hour after performing the installation.

16. **INSTALL CLUTCH DISC ASSEMBLY** (for Manual Transaxle) (See page [CL-16](#))
17. **INSTALL CLUTCH COVER ASSEMBLY** (for Manual Transaxle) (See page [CL-17](#))
18. **INSPECT AND ADJUST CLUTCH COVER ASSEMBLY** (for Manual Transaxle) (See page [CL-17](#))
19. **INSTALL MANUAL TRANSAXLE ASSEMBLY** (for Manual Transaxle) (See page [MX-30](#))
20. **INSTALL CONTROL CABLE BRACKET** (for Manual Transaxle) (See page [MX-32](#))
21. **INSTALL STARTER ASSEMBLY** (See page [ST-17](#))
22. **INSTALL FLYWHEEL HOUSING SIDE COVER** (See page [ST-17](#))
23. **CONNECT HEATER WATER INLET HOSE A**
 - (a) Connect heater water inlet hose A to the cylinder head.
24. **INSTALL WATER FILLER SUB-ASSEMBLY**
 - (a) Connect radiator hose No. 1 to the cylinder head.
 - (b) Install the water filler sub-assembly with the 2 nuts.
Torque: 7.5 N*m (76 kgf*cm, 66 in.*lbf)
 - (c) Connect radiator hose No. 1 to the water filler.
25. **INSTALL FUEL TUBE SUB-ASSEMBLY**
 - (a) Connect the fuel tube connector and pipe and install fuel pipe clamp No. 2.
CAUTION:
Align the fuel tube connector with the pipe, then push the fuel tube connector in until the retainer makes a click sound. If the connection is tight, apply a small amount of engine oil to the the tip of the pipe. After connecting, pull the pipe and connector to make sure that they are securely connected.
26. **INSTALL VENTILATION HOSE NO. 2**
 - (a) Install ventilation hose No. 2 with the clip.
27. **INSTALL VENTILATION HOSE**
 - (a) Install the ventilation hose with the clip.
28. **INSTALL FRONT SUSPENSION CROSSMEMBER SUB-ASSEMBLY**
 - (a) Install the engine moving control rod with the through bolt.
Torque: 120 N*m (1,224 kgf*cm, 89 ft.*lbf)
 - (b) Remove the 2 bolts and remove the 2 engine hangers.

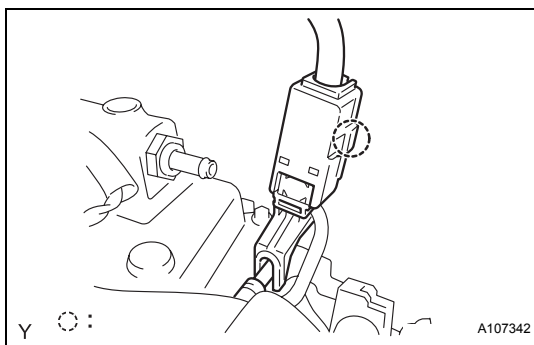

- (c) Install the oxygen sensor wiring bracket with the bolt.
Torque: 60 N*m (612 kgf*cm, 44 ft.*lbf)
- (d) Install the radio setting condenser with the bolt.
Torque: 40 N*m (408 kgf*cm, 30 ft.*lbf)

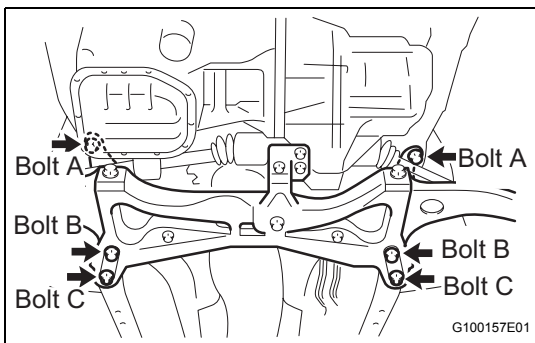
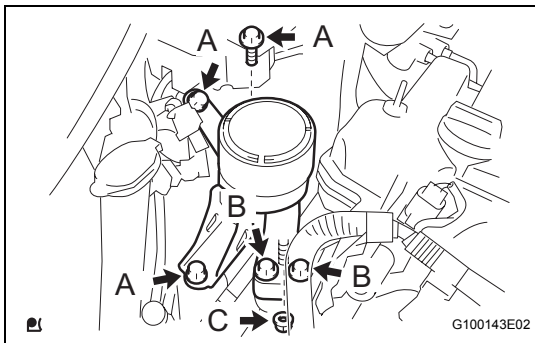
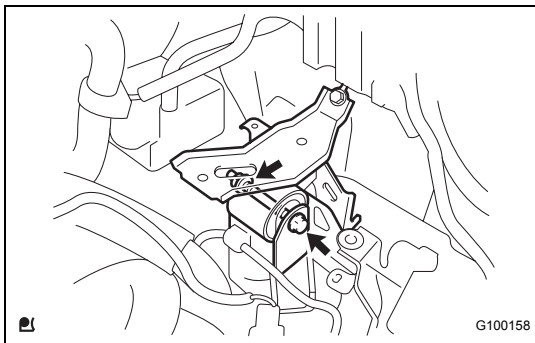
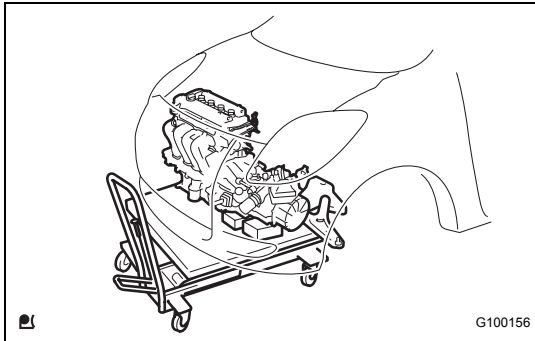

29. INSTALL ENGINE ASSEMBLY WITH TRANSAXLE (for Hatchback)

- (a) Set the engine assembly with transaxle and front suspension crossmember on the engine lifter.
- (b) Operate the engine lifter and lift the engine assembly with transaxle and front suspension crossmember to the position where the engine mounting insulators RH and LH can be installed.
- (c) Install the engine mounting insulator LH with the through bolt and nut.
Torque: 52 N*m (530 kgf*cm, 38 ft.*lbf)
- (d) Install the engine mounting insulator RH with the 5 bolts and nut.
Torque: 45 N*m (459 kgf*cm, 33 ft.*lbf) for Bolt A
52 N*m (530 kgf*cm, 38 ft.*lbf) for Bolt B
52 N*m (530 kgf*cm, 38 ft.*lbf) for Nut C
- (e) Operate the engine lifter and provisionally install the front suspension crossmember onto the vehicle with the 6 bolts.
- (f) Insert SST into the datum holes in the front suspension crossmembers RH and LH alternately and tighten bolts A, B and C on both sides in several sequences.
SST 09670-00010
Torque: 70 N*m (714 kgf*cm, 52 ft.*lbf) for Bolt A
160 N*m (1,631 kgf*cm, 118 ft.*lbf) for Bolt B
95 N*m (969 kgf*cm, 70 ft.*lbf) for Bolt C
- CAUTION:**
- Insert SST into the datum hole vertically.
 - If impossible to insert SST vertically, loosen all the bolts and then insert SST again.

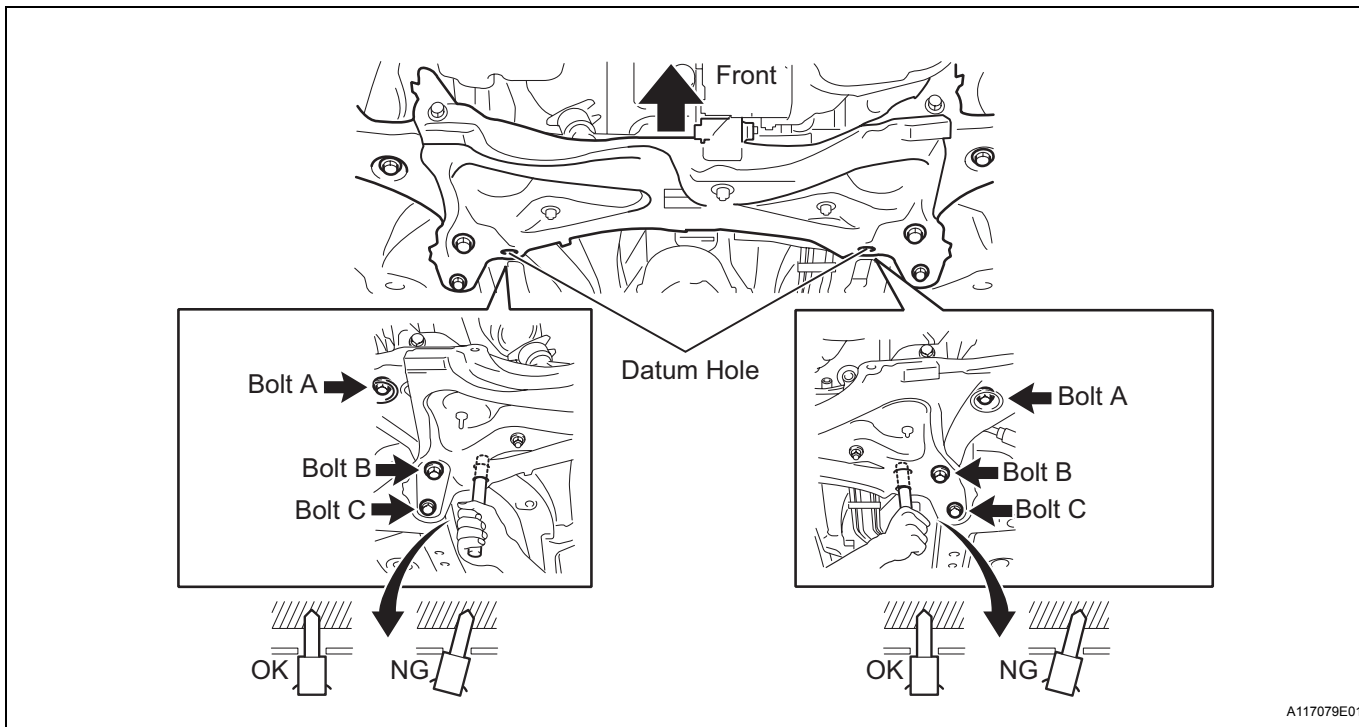

30. REMOVE ENGINE ASSEMBLY WITH TRANSAXLE (for Sedan)

- Set the engine assembly with transaxle and front suspension crossmember on the engine lifter.
- Operate the engine lifter and lift the engine assembly with transaxle and front suspension crossmember to the position where the engine mounting insulators RH and LH can be installed.

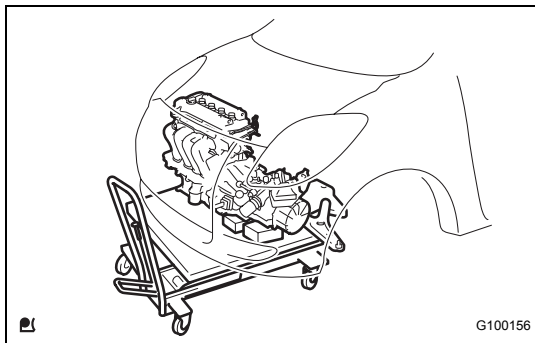

- Install the engine mounting insulator LH with the through bolt and nut.

Torque: 52 N*m (530 kgf*cm, 38 ft.*lbf)

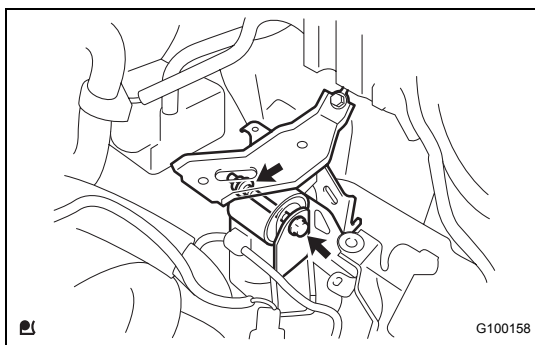

- Install the engine mounting insulator RH with the 5 bolts and nut.

Torque: 52 N*m (530 kgf*cm, 38 ft.*lbf)

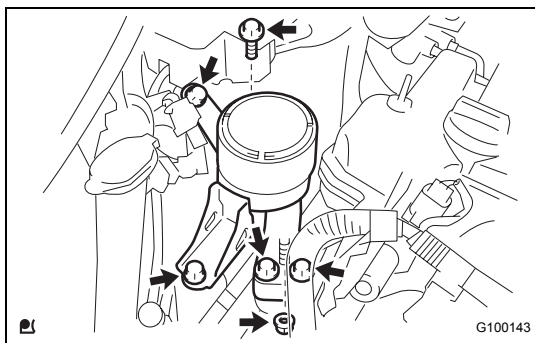

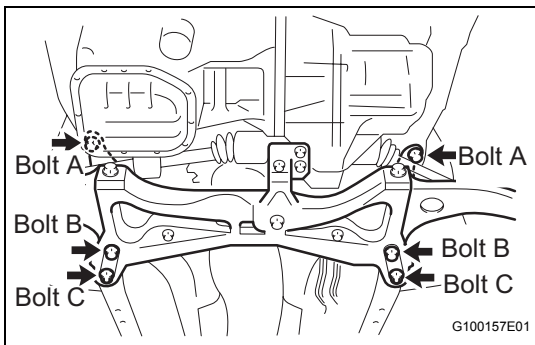

- (e) Operate the engine lifter and provisionally install the engine assembly with transaxle and front suspension crossmember onto the vehicle with the 6 bolts.
- (f) Insert SST into the datum holes of the front suspension crossmembers RH and LH alternately and tighten bolts A, B and C on both sides in several sequences.

SST 09670-00010

Torque: 70 N*m (714 kgf*cm, 52 ft.*lbf) for Bolt A
160 N*m (1,631 kgf*cm, 118 ft.*lbf) for Bolt B

95 N*m (969 kgf*cm, 70 ft.*lbf) for Bolt C

CAUTION:

- Insert SST into the datum hole vertically.
- If impossible to insert SST vertically, loosen all the bolts and then insert SST again.

EM

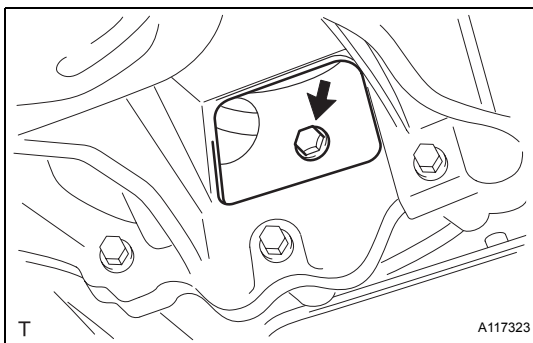
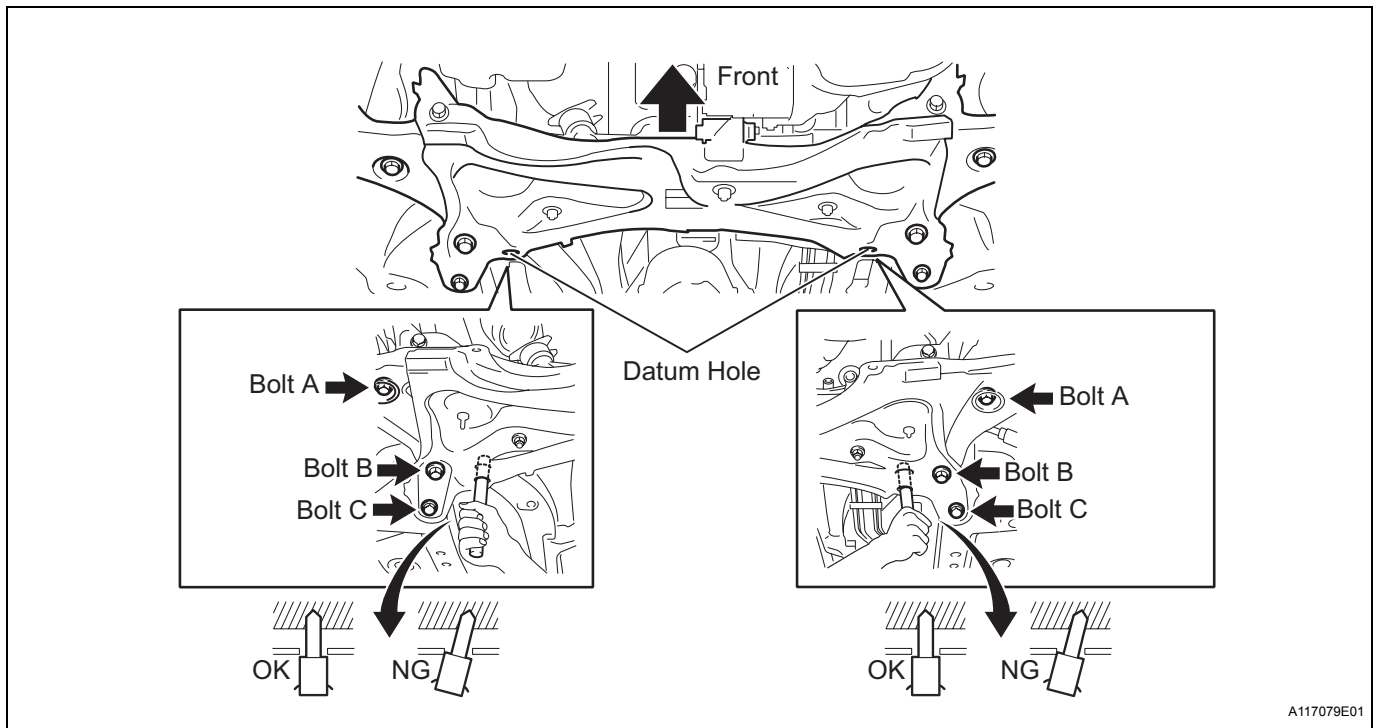

31. INSTALL DRIVE PLATE AND TORQUE CONVERTER CLUTCH SETTING BOLT (for Automatic Transaxle)

- (a) Tighten the 6 torque converter set bolts.

Torque: 27 N*m (275 kgf*cm, 20 ft.*lbf)

32. INSTALL FLYWHEEL HOUSING UNDER COVER

33. INSTALL FRONT DRIVE SHAFT ASSEMBLY LH (See page DS-13)

34. INSTALL FRONT DRIVE SHAFT ASSEMBLY RH (See page DS-14)

35. INSTALL FRONT AXLE ASSEMBLY LH (See page DS-14)

36. INSTALL FRONT AXLE ASSEMBLY RH (See page DS-14)

37. INSTALL FRONT STABILIZER LINK ASSEMBLY LH
(See page [DS-14](#))
38. INSTALL FRONT STABILIZER LINK ASSEMBLY RH
(See page [MX-31](#))
39. INSTALL FRONT SUSPENSION ARM SUB-
ASSEMBLY LOWER NO. 1 LH (See page [DS-14](#))
40. INSTALL FRONT SUSPENSION ARM SUB-
ASSEMBLY LOWER NO. 1 RH (See page [MX-31](#))
41. INSTALL TIE ROD END SUB-ASSEMBLY LH (See
page [DS-15](#))
42. INSTALL TIE ROD END SUB-ASSEMBLY RH (See
page [MX-31](#))
43. INSTALL SPEED SENSOR FRONT LH (w/ ABS) (See
page [DS-15](#))
44. INSTALL SPEED SENSOR FRONT RH (w/ ABS) (See
page [MX-31](#))
45. INSTALL FRONT AXLE HUB LH NUT (See page [DS-
15](#))
46. INSTALL FRONT AXLE HUB RH NUT (See page [MX-
31](#))
47. INSTALL EXHAUST PIPE ASSEMBLY FRONT (See
page [EX-8](#))
48. INSTALL HEATED OXYGEN SENSOR (See page [EC-
23](#))
49. INSTALL CONSOLE BOX ASSEMBLY REAR (See
page [PB-10](#))
50. INSTALL CONSOLE BOX REAR COVER (for
Hatchback) (See page [PB-11](#))
51. INSTALL SHIFTING HOLE COVER SUB-ASSEMBLY
(for Manual Transaxle) (See page [PB-12](#))
52. INSTALL CONSOLE BOX CARPET (for Sedan) (See
page [PB-11](#))
53. INSTALL CONSOLE UPPER REAR PANEL SUB-
ASSEMBLY (for Sedan) (See page [IP-89](#))
54. INSTALL UPPER CONSOLE PANEL SUB-ASSEMBLY
(for Sedan) (See page [IP-89](#))
55. INSTALL INSTRUMENT PAD LOWER LH (for Sedan)
(See page [IP-55](#))
56. INSTALL INSTRUMENT PANEL FINISH PANEL END
LH (for Sedan) (See page [ME-141](#))
57. INSTALL INSTRUMENT PANEL FINISH PANEL
LOWER CENTER (for Sedan) (See page [ME-142](#))
58. INSTALL SHIFT LEVER KNOB SUB-ASSEMBLY (for
Manual Transaxle)

59. INSTALL STEERING COLUMN HOLE COVER SUB-ASSEMBLY NO. 1 (See page [PS-79](#))
60. INSTALL STEERING SLIDING YOKE SUB-ASSEMBLY (See page [PS-79](#))
61. INSTALL COLUMN HOLE COVER SILENCER SHEET (See page [PS-79](#))
62. CONNECT ENGINE WIRE

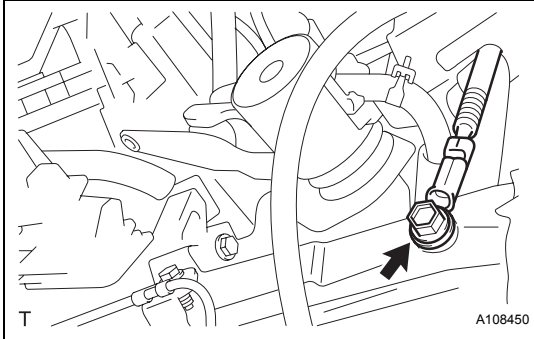

- (a) Install the earth wire of the engine room wire harness with the bolt.

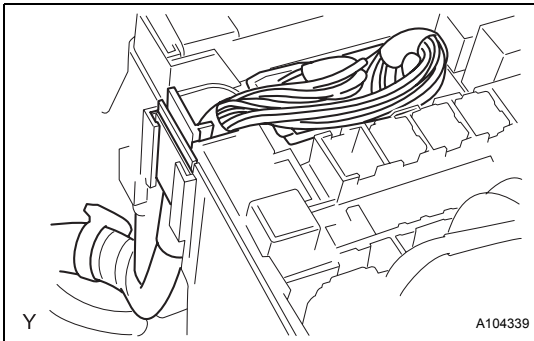

- (b) Connect the 2 engine wire harness connectors and wire harness clamp to the engine room junction block.

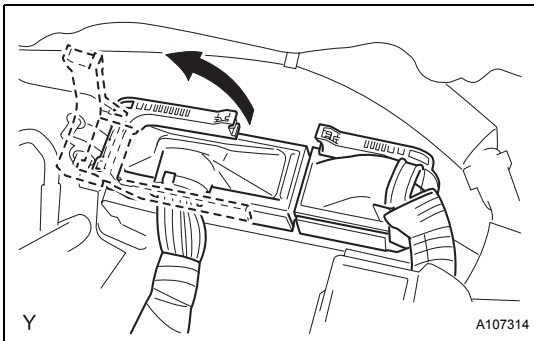

- (c) Connect the engine wire harness connector to the ECM.

63. INSTALL CLUTCH RELEASE CYLINDER ASSEMBLY (for Manual Transaxle) (See page [MX-32](#))
64. INSTALL WITH PULLEY COMPRESSOR ASSEMBLY (w/ Air Conditioning System) (See page [AC-209](#))
65. INSTALL FAN AND GENERATOR V BELT (See page [EM-7](#))
66. ADJUST FAN AND GENERATOR V BELT (See page [EM-7](#))
67. CONNECT FUEL TUBE SUB-ASSEMBLY

- (a) Connect the fuel tube connector and fuel pipe, and install fuel pipe clamp No. 1.

CAUTION:

Align the fuel tube connector with the pipe, then push the fuel tube connector in until the retainer makes a click sound. If the connection is tight, apply a small amount of engine oil to the tip of the pipe. After connecting, pull the pipe and connector to make sure that they are securely connected.

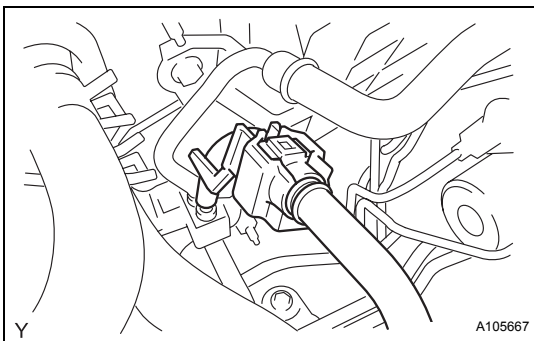

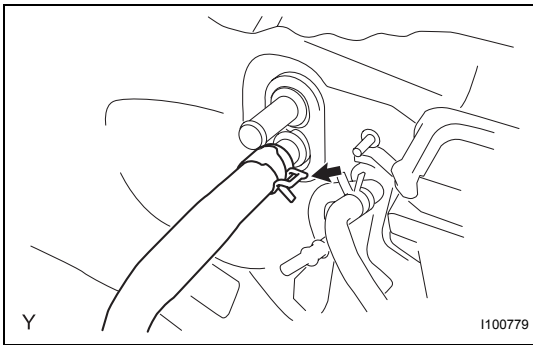
**68. CONNECT HEATER WATER INLET HOSE A**

- (a) Connect heater water inlet hose A to the heater unit.

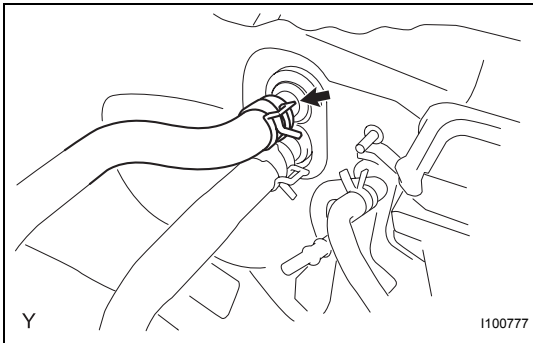
**69. CONNECT HEATER WATER OUTLET HOSE A (FROM HEATER UNIT)**

- (a) Connect heater water outlet hose A to the heater unit.

70. CONNECT UNION TO CHECK VALVE HOSE

- (a) Connect the union to check valve hose to the booster vacuum tube.

71. INSTALL TRANSMISSION CONTROL CABLE ASSEMBLY (for Automatic Transaxle) (See page AX-109)**72. INSTALL TRANSMISSION CONTROL CABLE ASSEMBLY (for Manual Transaxle) (See page MX-32)****73. INSTALL CYLINDER HEAD COVER NO. 2 (See page IG-10)****74. CONNECT OIL COOLER INLET HOSE (for Automatic Transaxle)**

- (a) Connect the oil cooler inlet hose with the clip.

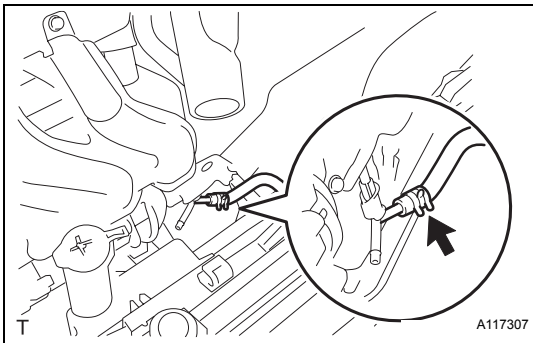
**75. CONNECT OIL COOLER OUTLET HOSE (for Automatic Transaxle)**

- (a) Connect the oil cooler outlet hose with the clip.

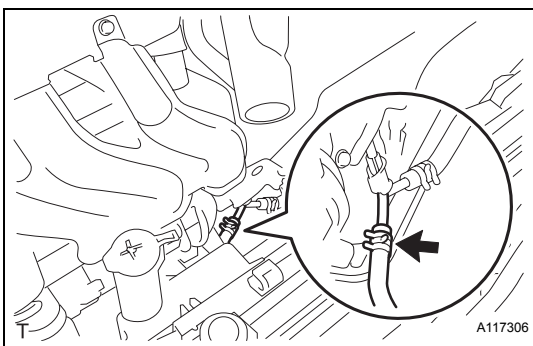

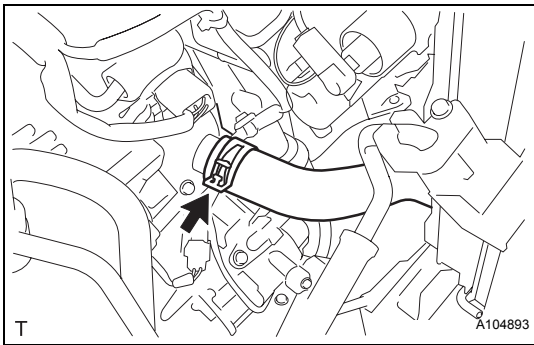
**76. CONNECT RADIATOR HOSE NO. 2**

- (a) Connect radiator hose No. 2 to the water inlet.

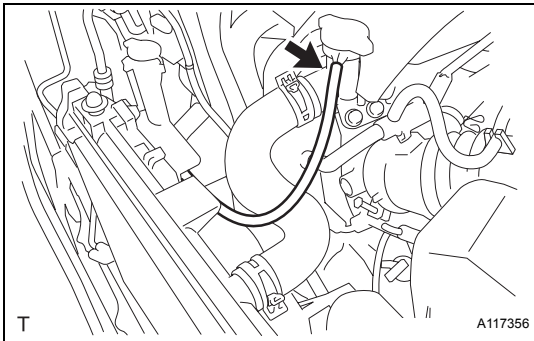
**77. CONNECT RADIATOR RESERVOIR TANK HOSE**

- (a) Connect the radiator reservoir tank hose to the water filler.

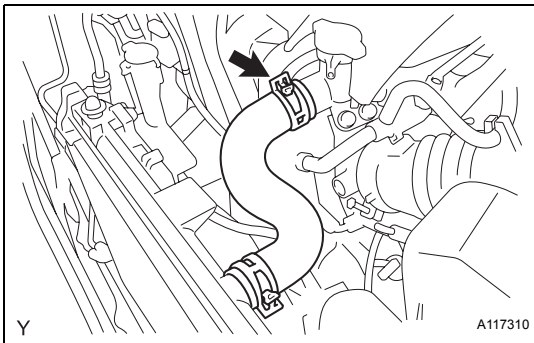
**78. CONNECT RADIATOR HOSE NO. 3**

- (a) Connect radiator hose No. 3 to the water filler.

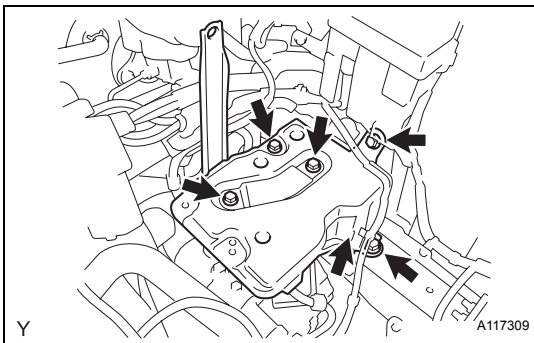
**79. INSTALL BATTERY CARRIER**

- (a) Install the battery carrier with the 5 bolts.
Torque: 17 N*m (173 kgf*cm, 13 ft.*lbf)
 (b) Install the clamp.

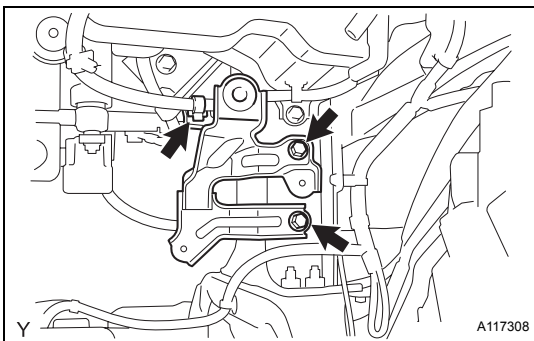
**80. INSTALL AIR CLEANER BRACKET**

- (a) Install the air cleaner bracket with the 2 bolts.
Torque: 19 N*m (194 kgf*cm, 14 ft.*lbf)
 (b) Connect the wire harness clamp to the air cleaner bracket.

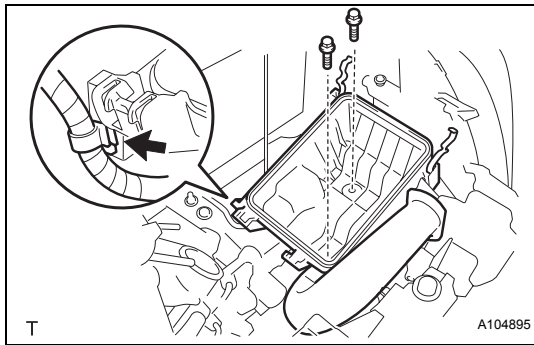
**81. INSTALL AIR CLEANER ASSEMBLY**

- (a) Install the air cleaner case with air cleaner inlet No. 1 with the 2 bolts.

Torque: 7.8 N*m (80 kgf*cm, 69 in.*lbf)

- (b) Connect the wire harness to the air cleaner case.
 (c) Install the air cleaner element.

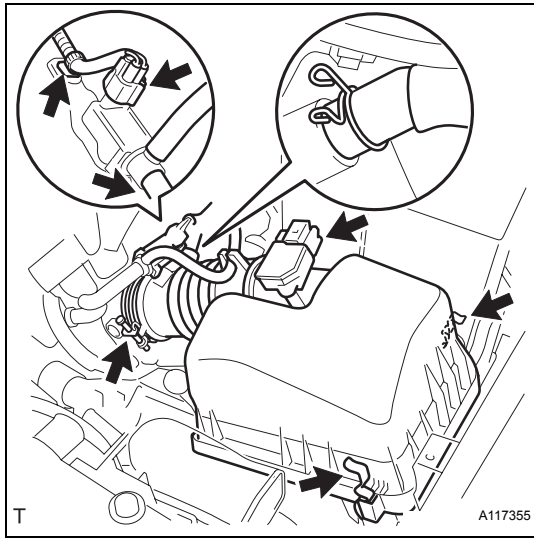

- (d) Install and lock the air cleaner cap and the air cleaner hose and then tighten the air cleaner hose clamp.

Torque: 4.0 N*m (41 kgf*cm, 35 in.*lbf)

- (e) Connect the ventilation hose to the air cleaner hose.
 (f) Connect the vacuum switching valve connector and the wire harness clamp.
 (g) Connect the fuel vapor feed hose and fuel vapor feed hose No. 1 to the vacuum switching valve assembly.
 (h) Connect the intake air flow meter connector and the wire harness clamp.

**82. INSTALL COWL TOP PANEL OUTER (for Hatchback)**

- (a) Install the cowl top panel with the 9 bolts.

Torque: 6.5 N*m (66 kgf*cm, 58 ft.*lbf)

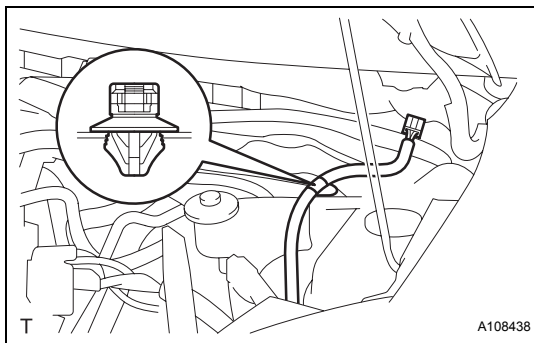

- (b) Connect the wire harness clamp.

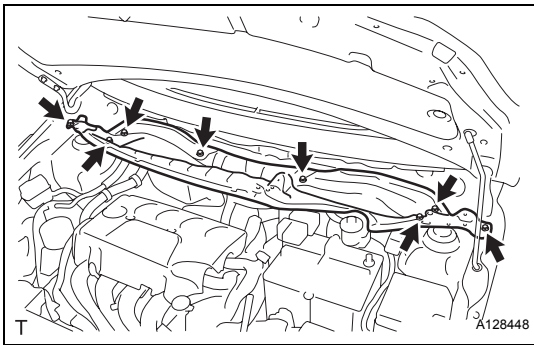
**83. INSTALL COWL TOP PANEL OUTER (for Sedan)**

- (a) Install the cowl top panel outer with the 8 bolts.
Torque: 6.5 N*m (66 kgf*cm, 58 in.*lbf)

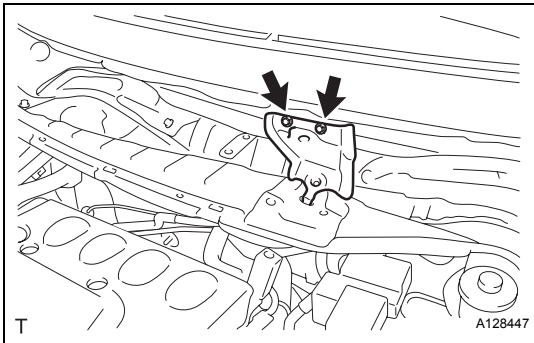

- (b) Install the cowl top to cowl inner brace with the 2 bolts.
Torque: 6.5 N*m (66 kgf*cm, 58 in.*lbf)

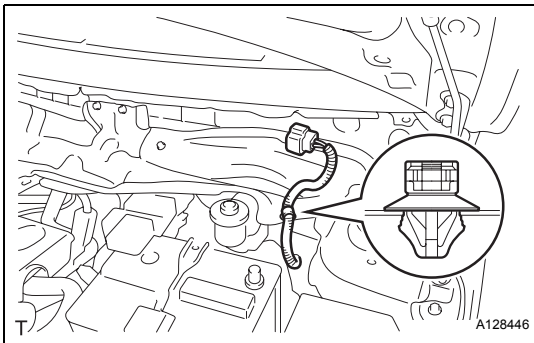

- (c) Connect the wire harness clamp.

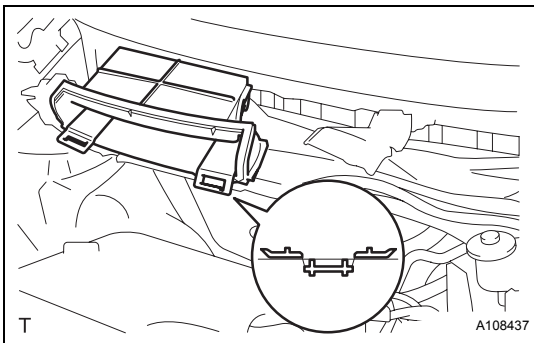
**84. INSTALL COWL TO REGISTER DUCT SUB-ASSEMBLY NO. 2 (for Hatchback)**

- (a) Engage the claw and install cowl to register duct No. 2.

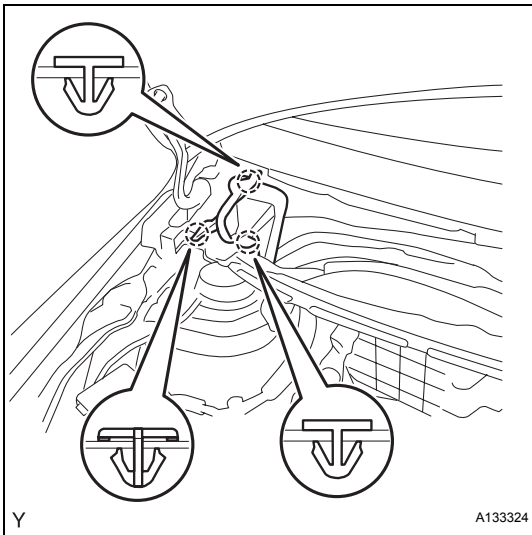

85. **INSTALL FRONT AIR SHUTTER SEAL RH (for Sedan)**
 - (a) Engage the 3 claws to install the front air shutter seal RH.
86. **INSTALL FRONT WIPER MOTOR AND LINK (See page [WW-21](#))**
87. **INSTALL COWL TOP VENTILATOR LOUVER LH (for Hatchback) (See page [WW-21](#))**
88. **INSTALL COWL TOP VENTILATOR LOUVER SUB-ASSEMBLY (for Hatchback) (See page [WW-21](#))**
89. **INSTALL HOOD TO COWL TOP SEAL (for Hatchback) (See page [WW-22](#))**
90. **INSTALL COWL TOP VENTILATOR LOUVER SUB-ASSEMBLY (for Sedan) (See page [WW-12](#))**
91. **INSTALL COWL SIDE VENTILATOR SUB-ASSEMBLY LH (for Sedan) (See page [WW-13](#))**
92. **INSTALL COWL SIDE VENTILATOR SUB-ASSEMBLY RH (for Sedan) (See page [WW-13](#))**
93. **INSTALL FRONT WIPER ARM LH (See page [WW-22](#))**
94. **INSTALL FRONT WIPER ARM RH (See page [WW-23](#))**
95. **INSTALL FRONT WIPER ARM HEAD CAP (See page [WW-23](#))**
96. **INSTALL BATTERY TRAY**
97. **INSTALL BATTERY**
 - (a) Install the battery onto the vehicle with the battery clamp.
Torque: 3.5 N*m (36 kgf*cm, 31 in.*lbf)
 - (b) Connect the cable to the battery terminal.
Torque: 5.4 N*m (55 kgf*cm, 48 in.*lbf)
98. **ADD ENGINE COOLANT (See page [CO-8](#))**
99. **ADD AUTOMATIC TRANSAXLE FLUID (for Automatic Transaxle) (See page [AX-169](#))**
100. **INSPECT AUTOMATIC TRANSAXLE FLUID (for Automatic Transaxle) (See page [AX-93](#))**
101. **ADD MANUAL TRANSAXLE OIL (for Manual Transaxle)**
102. **INSPECT MANUAL TRANSAXLE OIL (for Manual Transaxle) (See page [MX-2](#))**
103. **INSPECT FAN AND GENERATOR V BELT (See page [EM-8](#))**
104. **CHECK FOR FUEL LEAKAGE (See page [FU-7](#))**
105. **CHECK FOR ENGINE OIL LEAKAGE**
106. **CHECK FOR EXHAUST GAS LEAKAGE**
107. **CHECK FOR ENGINE COOLANT LEAKAGE (See page [CO-1](#))**

-
- 108. INSTALL ENGINE UNDER COVER RH
 - 109. INSTALL ENGINE UNDER COVER LH
 - 110. INSTALL FRONT WHEELS
Torque: 103 N*m (1,050 kgf*cm, 76 ft.*lbf)
 - 111. INSPECT IGNITION TIMING (See page [EM-1](#))
 - 112. INSPECT ENGINE IDLING SPEED (See page [EM-2](#))
 - 113. INSPECT CO/HC (See page [EM-4](#))
 - 114. INSPECT FRONT WHEEL ALIGNMENT
 - 115. INSPECT ABS SENSOR SIGNAL (w/ ABS)

ENGINE UNIT

COMPONENTS

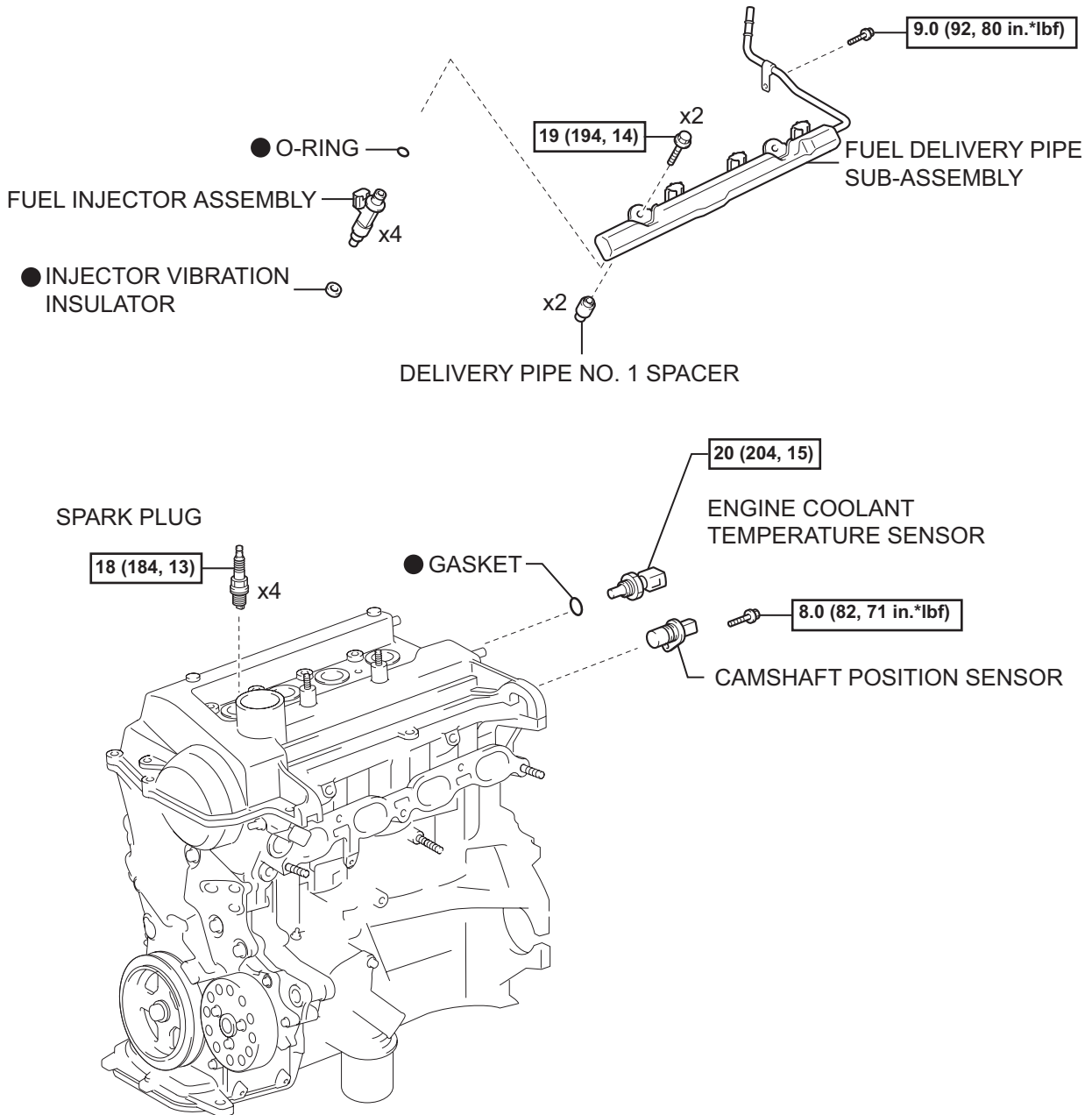

N*m (kgf*cm, ft.*lbf) : Specified torque

● Non-reusable part

EM

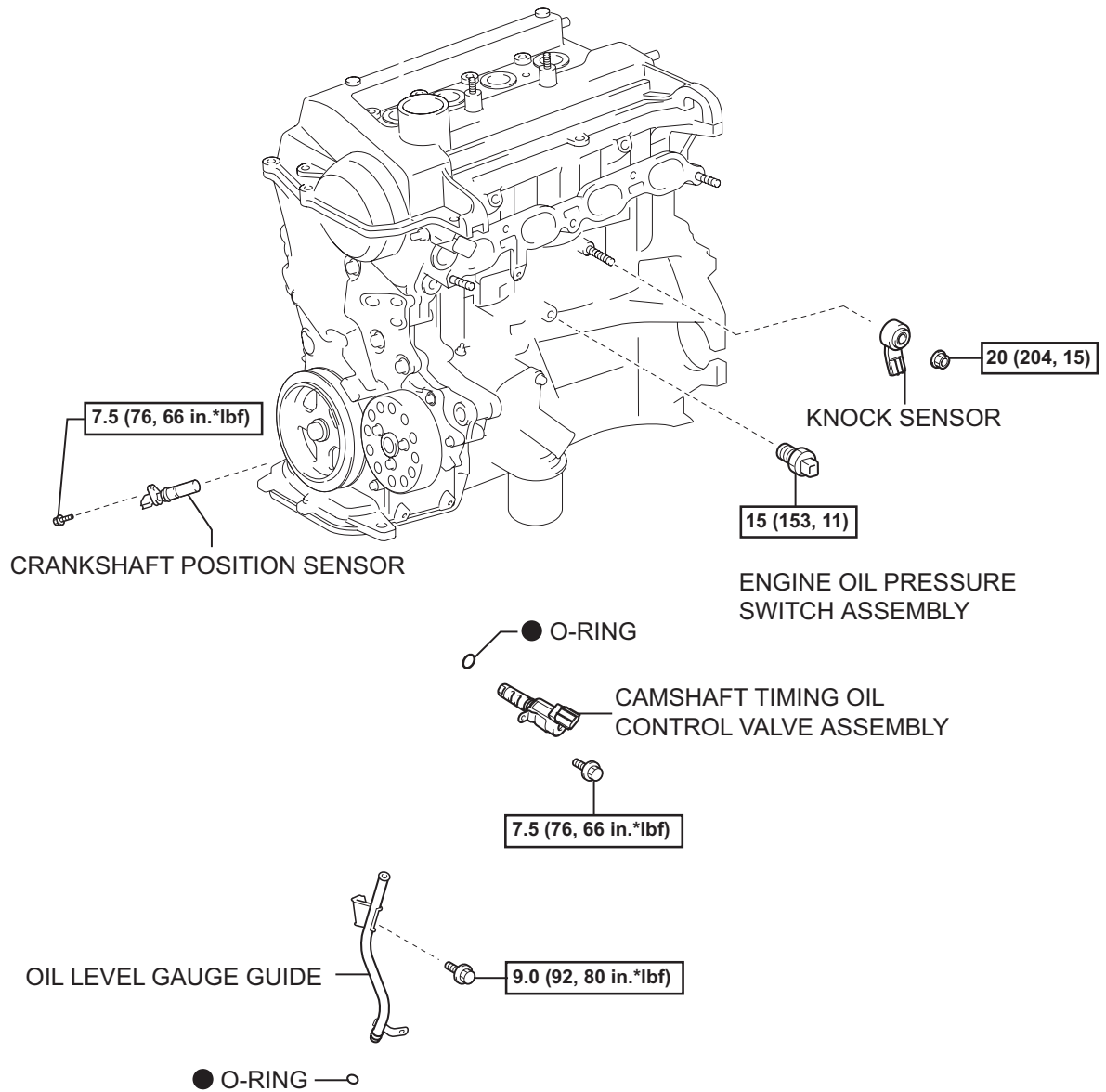

N*m (kgf*cm, ft.*lbf) : Specified torque

● Non-reusable part

EM

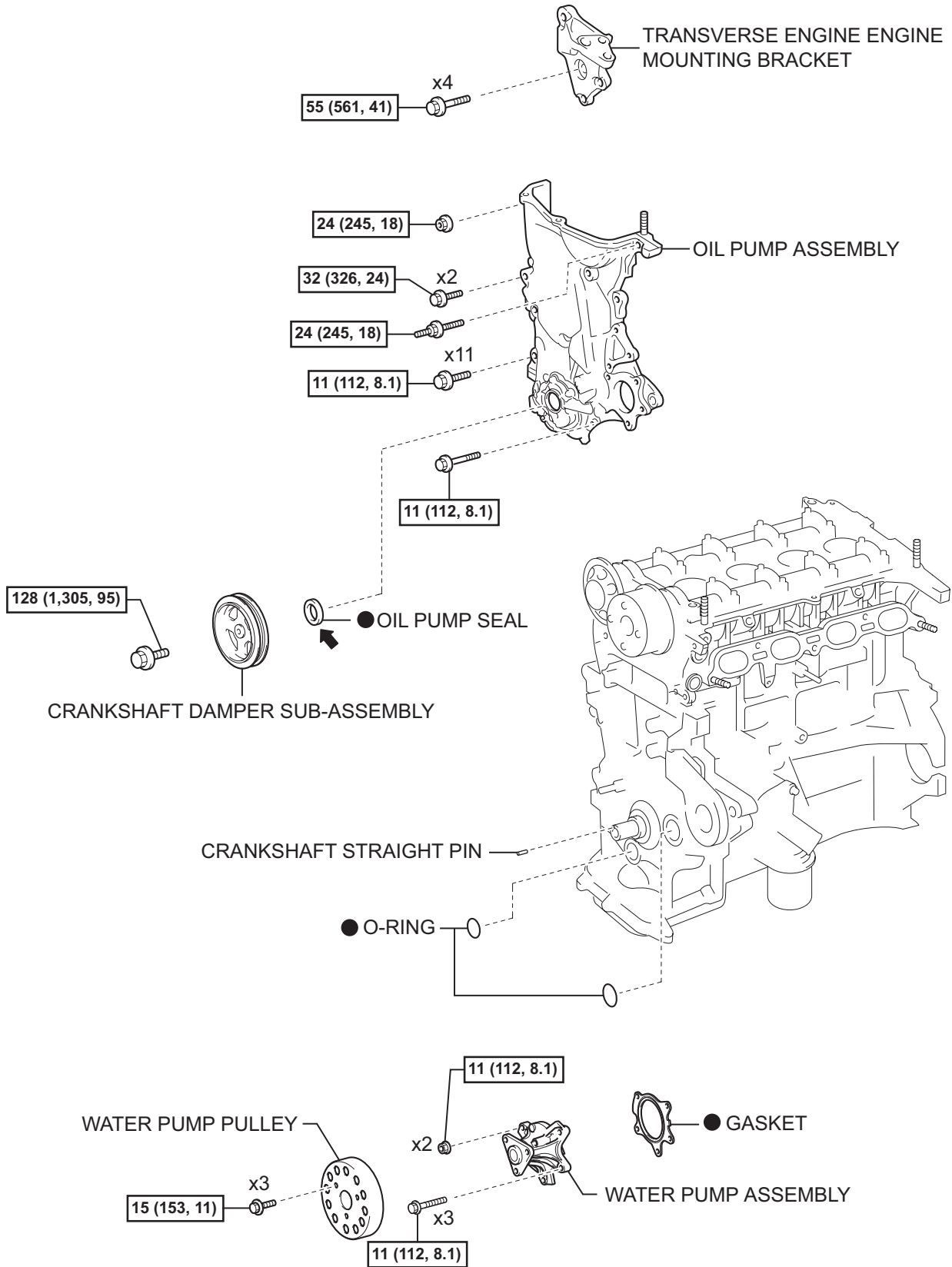

N*m (kgf*cm, ft.*lbf) : Specified torque ● Non-reusable part ← Apply MP grease

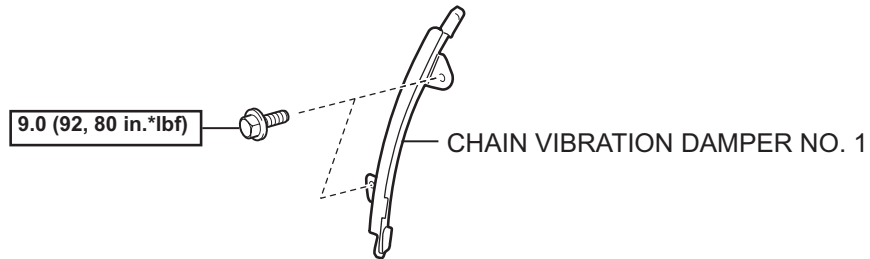
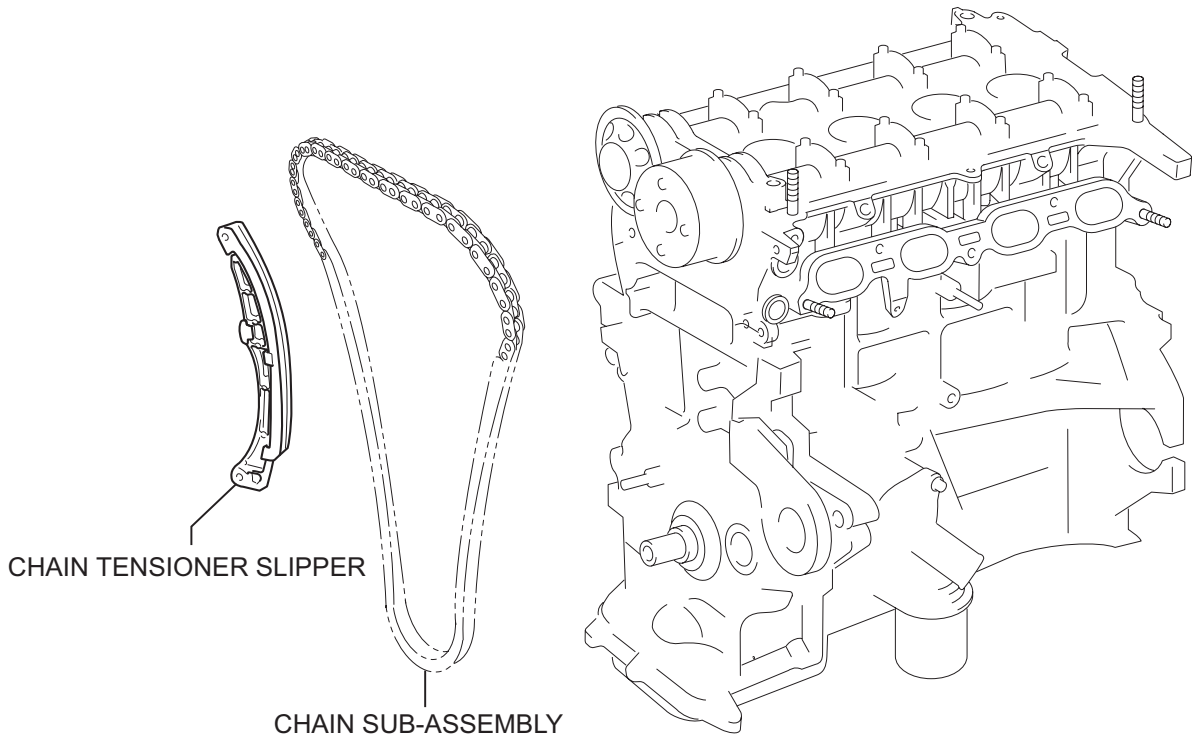
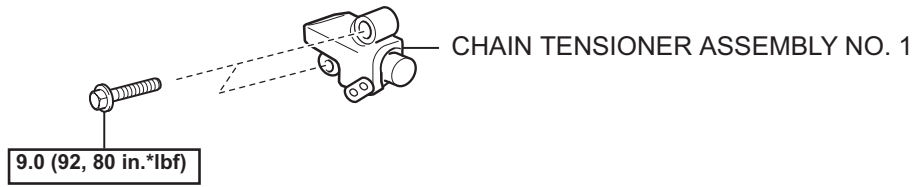

N*m (kgf*cm, ft.*lbf) : Specified torque

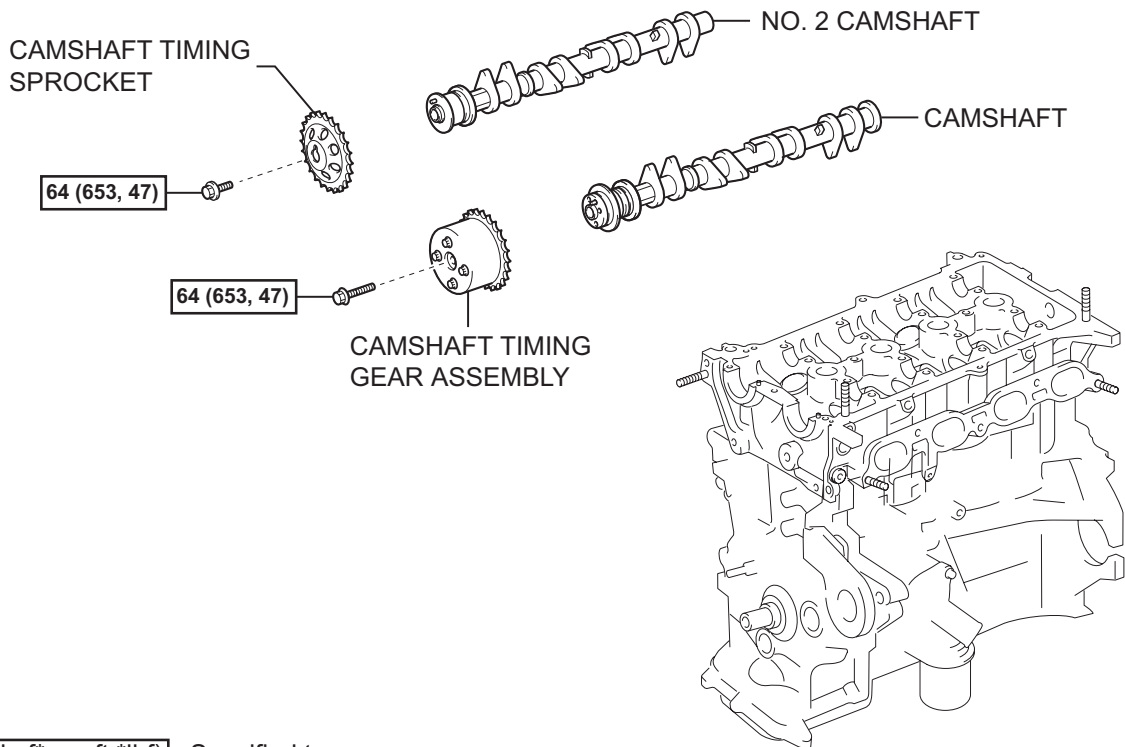
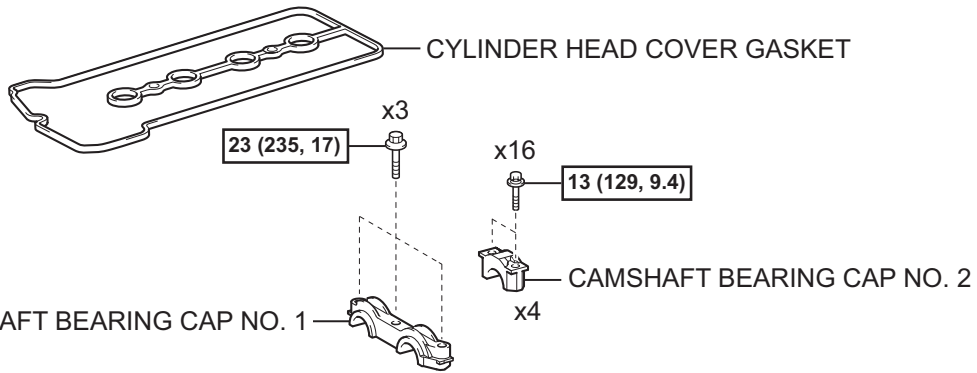
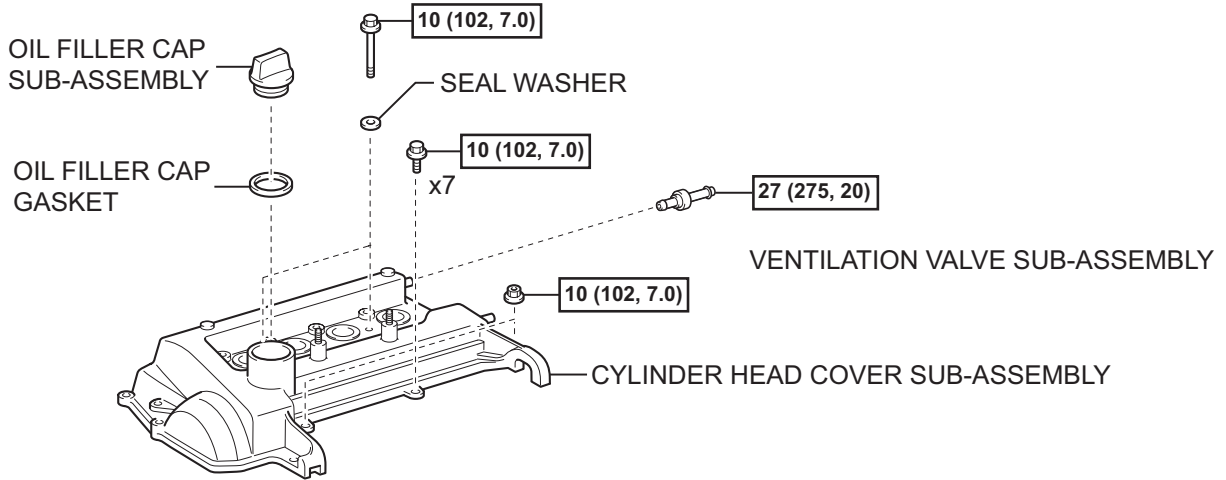

N*m (kgf*cm, ft.*lbf) : Specified torque

EM

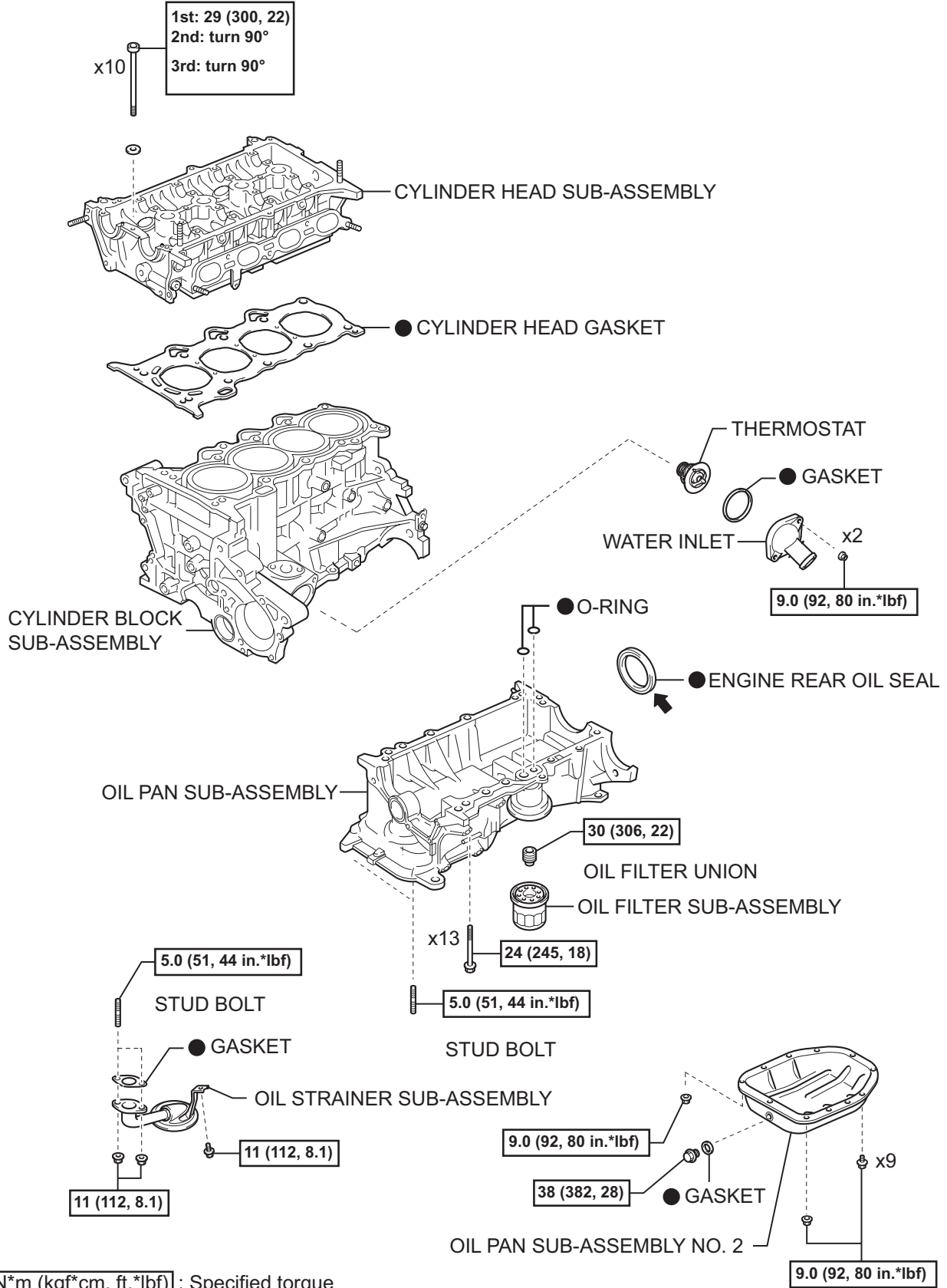

[N*m (kgf*cm, ft.*lbf)] : Specified torque

● Non-reusable part ← Apply MP grease

EM

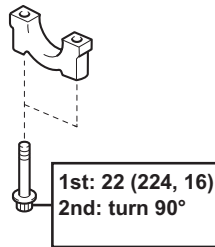
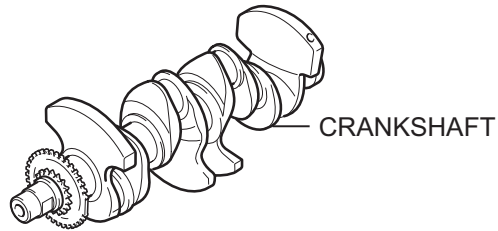
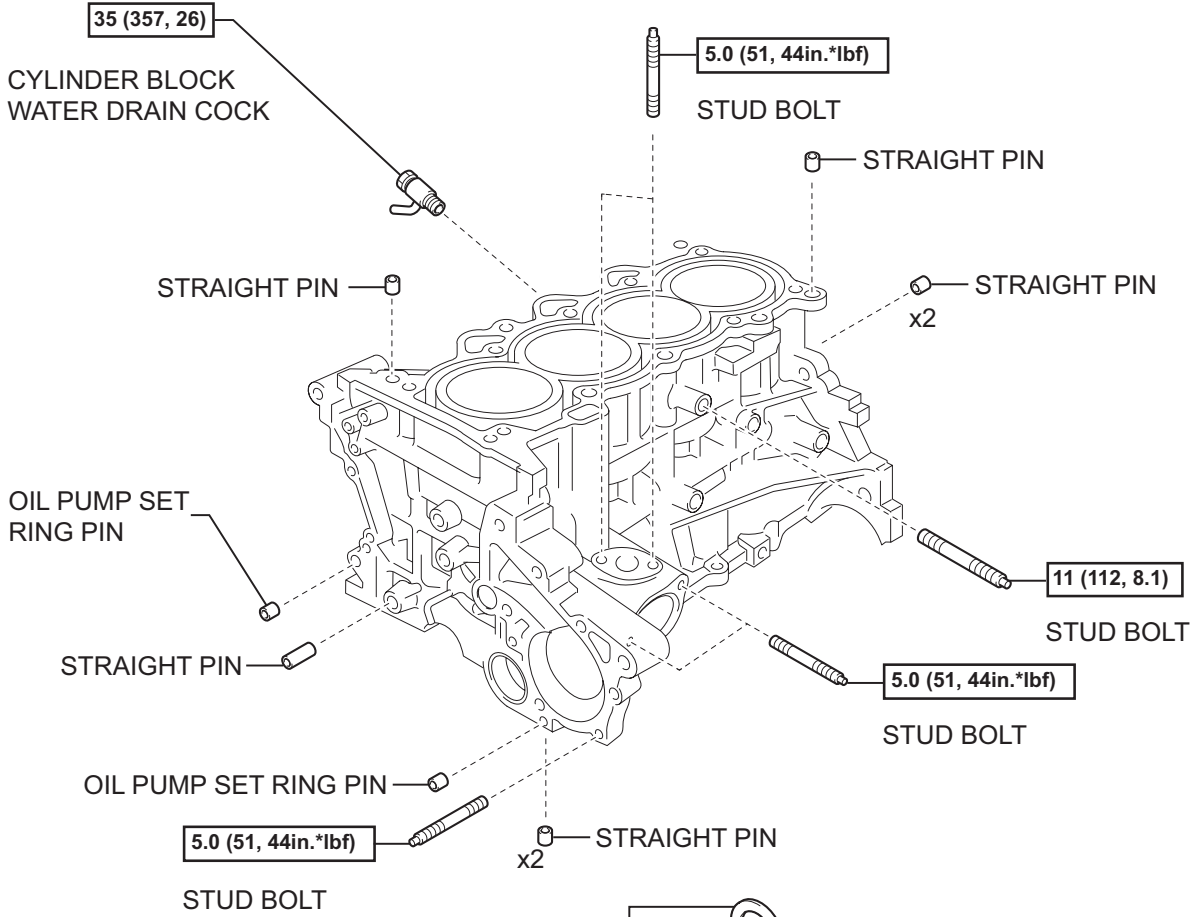

CRANKSHAFT BEARING CAP SET BOLT

N*m (kgf*cm, ft.*lbf) : Specified torque

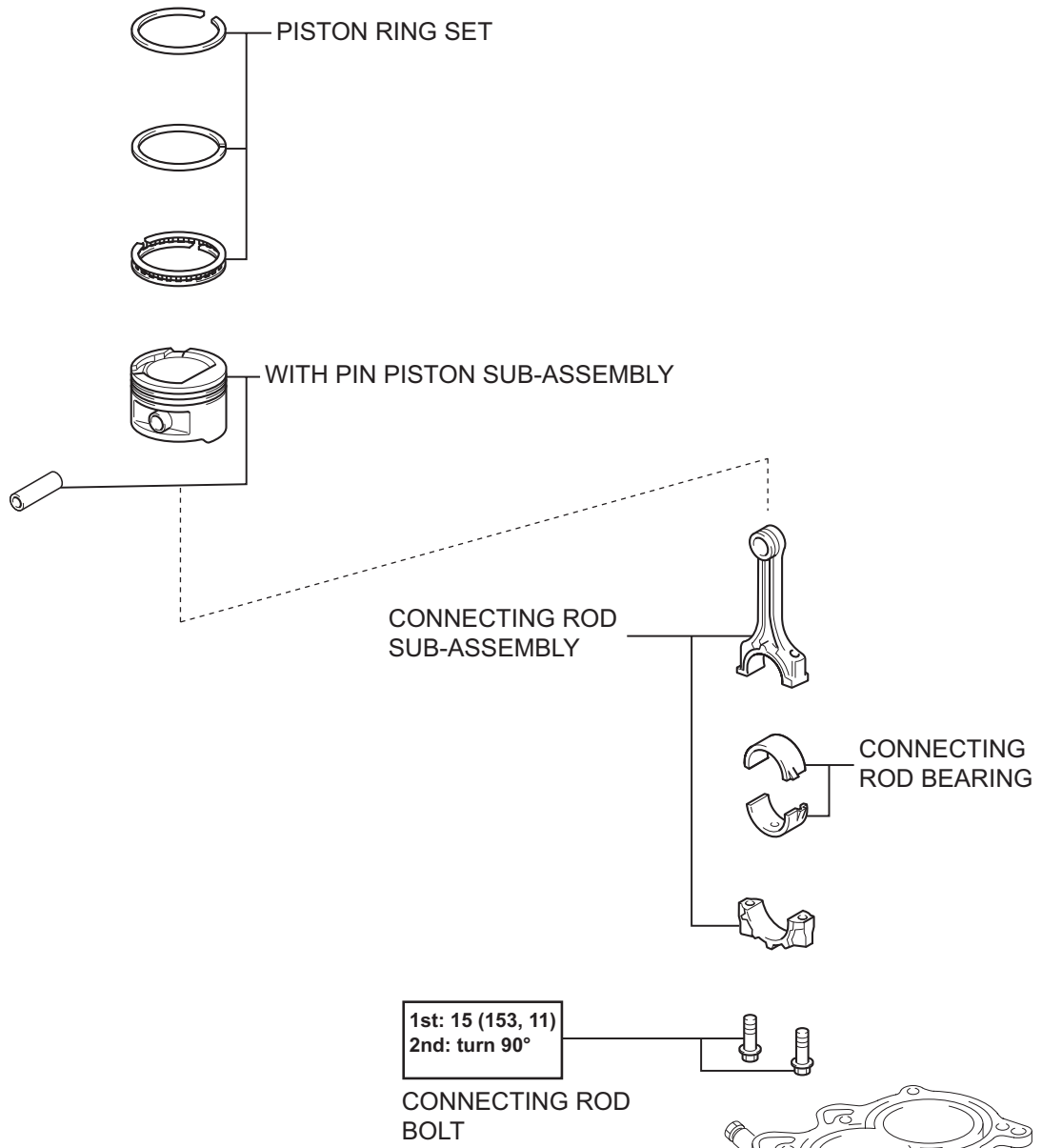

N*m (kgf*cm, ft.*lbf) : Specified torque

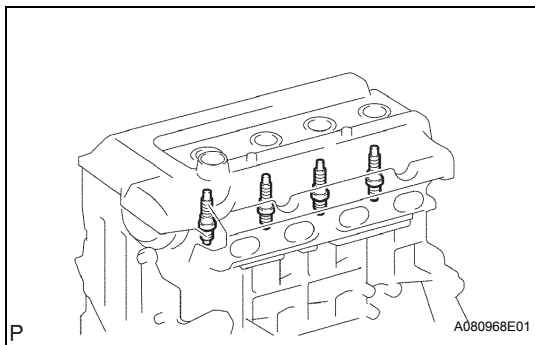
DISASSEMBLY**1. REMOVE SPARK PLUG**

- (a) Using a spark plug wrench, remove the 4 spark plugs.

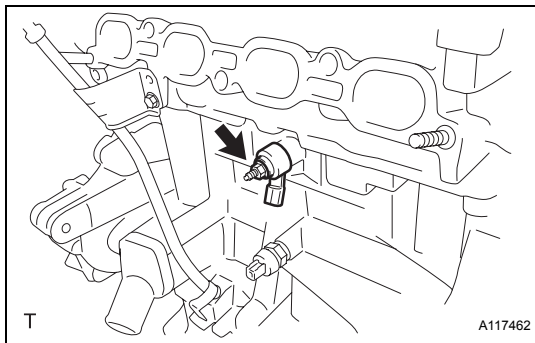
**2. REMOVE KNOCK SENSOR**

- (a) Remove the nut and remove the knock sensor.

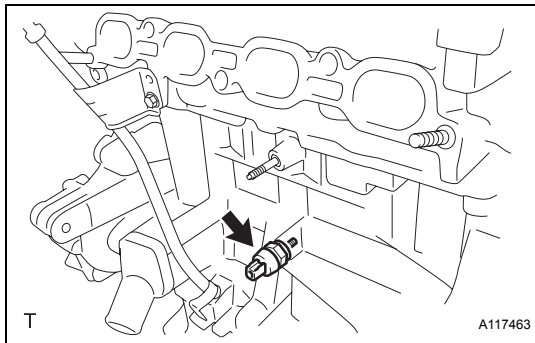
**3. REMOVE ENGINE OIL PRESSURE SWITCH ASSEMBLY**

- (a) Using a 24 mm deep socket wrench, remove the oil pressure switch.

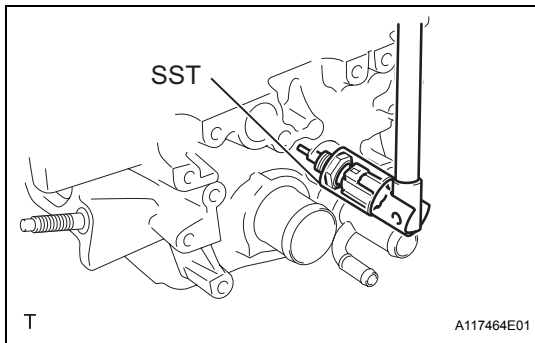
**4. REMOVE ENGINE COOLANT TEMPERATURE SENSOR**

- (a) Using SST, remove the engine coolant temperature sensor.

SST 09817-33190

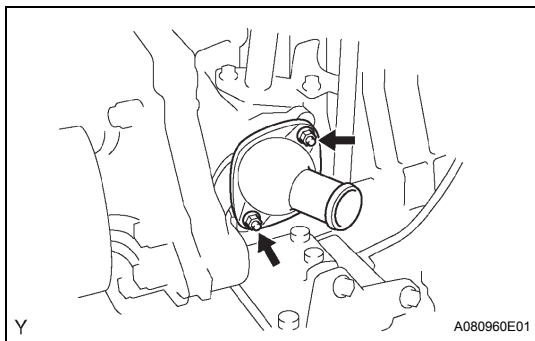
**5. REMOVE WATER INLET**

- (a) Remove the 2 nuts and remove the water inlet.

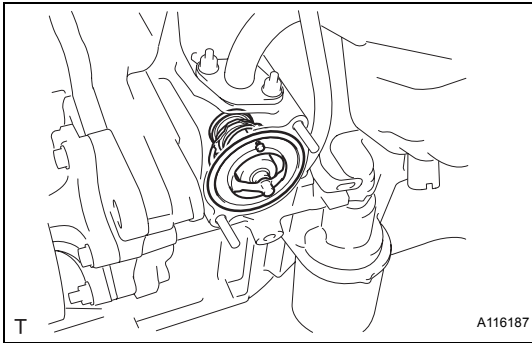
**6. REMOVE THERMOSTAT**

- (a) Remove the thermostat.
- (b) Remove the gasket from the thermostat.

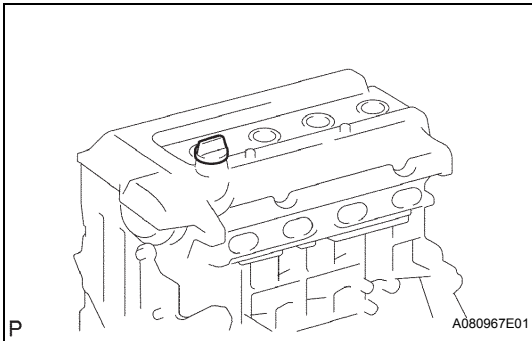
**7. REMOVE OIL FILLER CAP SUB-ASSEMBLY**

- (a) Remove the oil filler cap from the cylinder head cover.

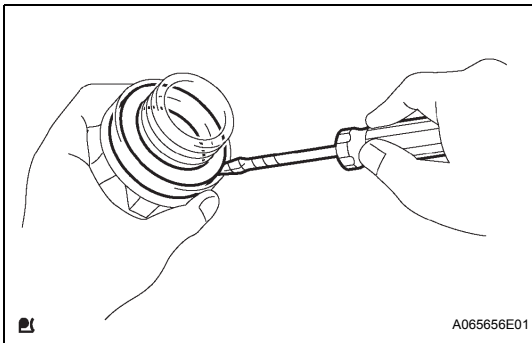
**8. REMOVE OIL FILLER CAP GASKET**

- (a) Using a screwdriver, remove the gasket from the oil filler cap.

9. REMOVE CRANKSHAFT POSITION SENSOR

- (a) Remove the bolt and the crankshaft position sensor.

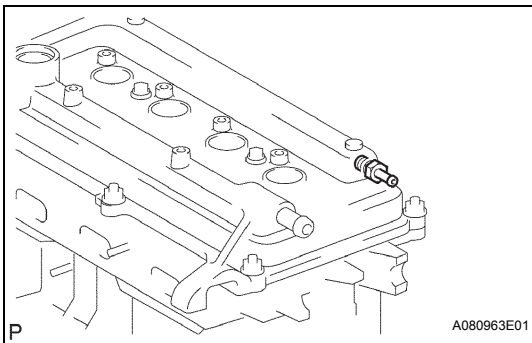
**10. REMOVE VENTILATION VALVE SUB-ASSEMBLY**

- (a) Remove the ventilation valve from the cylinder head cover.

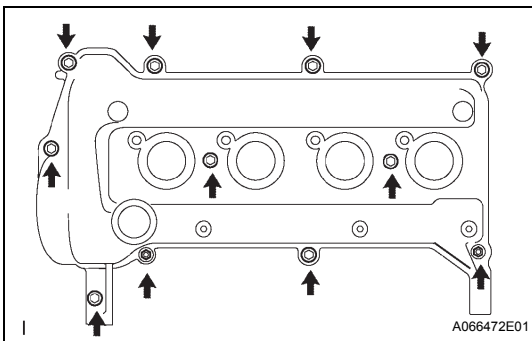
**11. REMOVE CYLINDER HEAD COVER SUB-ASSEMBLY**

- (a) Remove the 9 bolts, 2 nuts and 2 seal washers and then remove the cylinder head cover sub-assembly.

12. REMOVE CYLINDER HEAD COVER GASKET

- (a) Remove the gasket from the cylinder head cover.

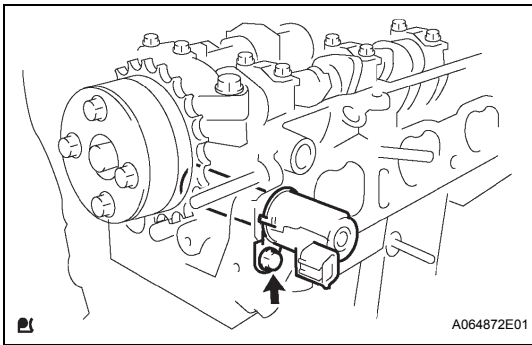

13. REMOVE CAMSHAFT TIMING OIL CONTROL VALVE ASSEMBLY

- (a) Remove the bolt and the camshaft timing oil control valve.

14. REMOVE OIL LEVEL GAUGE GUIDE

- (a) Remove the bolt and the oil level gauge guide.

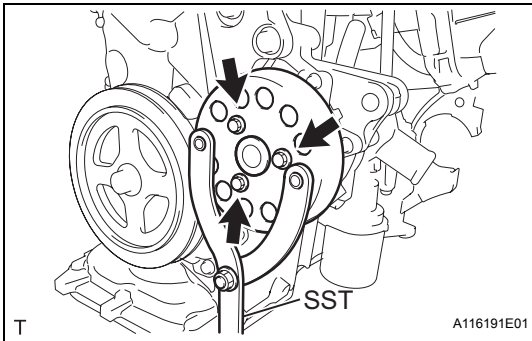

15. REMOVE WATER PUMP PULLEY

- (a) Using SST, hold the pump pulley.
SST 09960-10010 (09962-01000, 09963-00700)
 (b) Remove the 3 bolts and the pump pulley.

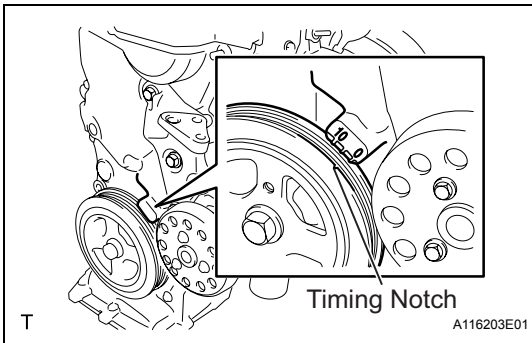

16. REMOVE CRANKSHAFT DAMPER SUB-ASSEMBLY

- (a) Set cylinder No. 1 to TDC/compression.
 (1) Turn the crankshaft damper sub-assembly, and align its timing notch with timing mark "0" of the oil pump.

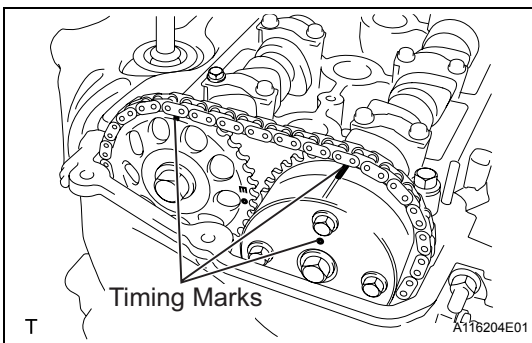

- (2) Check that the timing marks on the camshaft timing sprocket and the camshaft timing gear are all facing upward, as shown in the illustration.

If not, turn the crankshaft 1 complete revolution (360°) and align the marks as above.

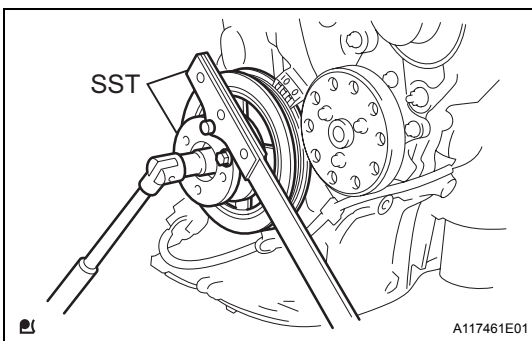

- (b) Using 2 SSTs, loosen the bolt while holding the crankshaft damper sub-assembly.
SST 09213-14010 (91651-60865), 09330-00021

NOTICE:
 Check the SST installation positions when installing them, to avoid the SST fixing bolts from coming into contact with the oil pump assembly.

- (c) Remove the SSTs and the bolt.
 (d) Remove the crankshaft damper sub-assembly.

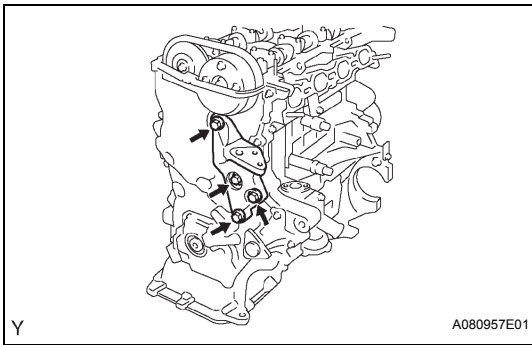

17. REMOVE TRANSVERSE ENGINE ENGINE MOUNTING BRACKET

- (a) Remove the 4 bolts and remove the transverse engine mounting bracket.

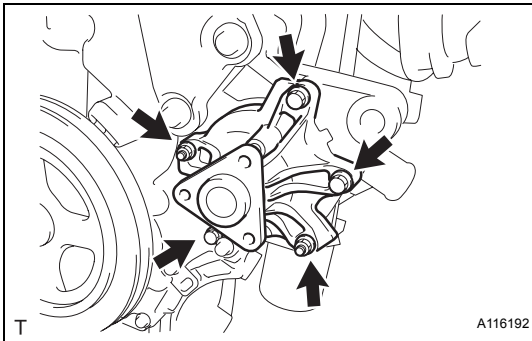

18. REMOVE WATER PUMP ASSEMBLY

- (a) Remove the 3 bolts and the 2 nuts and remove the water pump and the gasket.

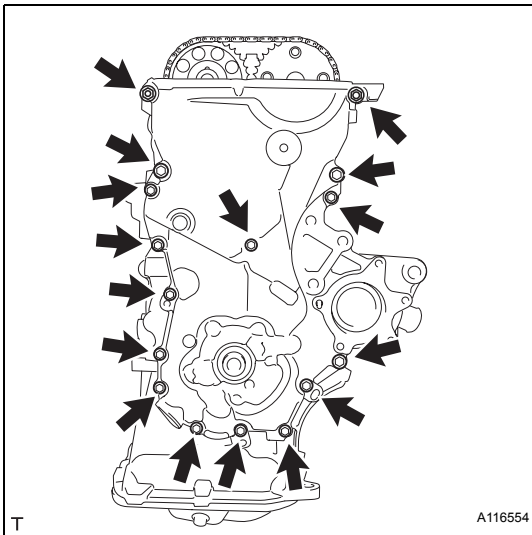

19. REMOVE OIL PUMP ASSEMBLY

- (a) Remove the 15 bolts and the nut.

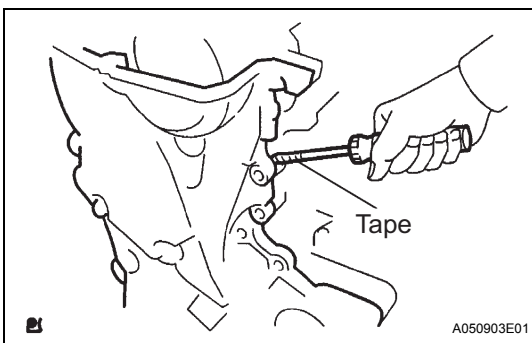

- (b) Using a screwdriver with its tip wrapped in protective tape, prize the oil pump assembly to remove it.

NOTICE:

Do not damage the contact surface of the oil pump assembly and oil pan sub-assembly.

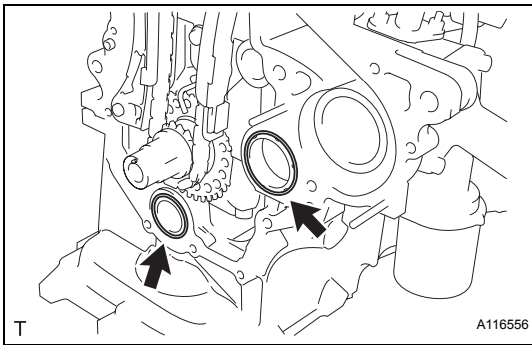

- (c) Remove the 2 O-rings from the cylinder block and oil pan sub-assembly.

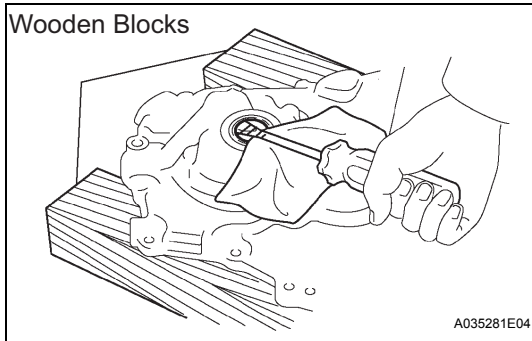

20. REMOVE OIL PUMP SEAL

- (a) Using a screwdriver with its tip wrapped in tape, remove the oil seal.

21. REMOVE CHAIN TENSIONER ASSEMBLY NO. 1

NOTICE:

- Do not rotate the crankshaft with the chain tensioner removed.
- When rotating the camshaft with the timing chain removed, rotate the crankshaft counterclockwise 40° from the TDC first.

- (a) Pull up the stopper plate and hold it with its lock released.

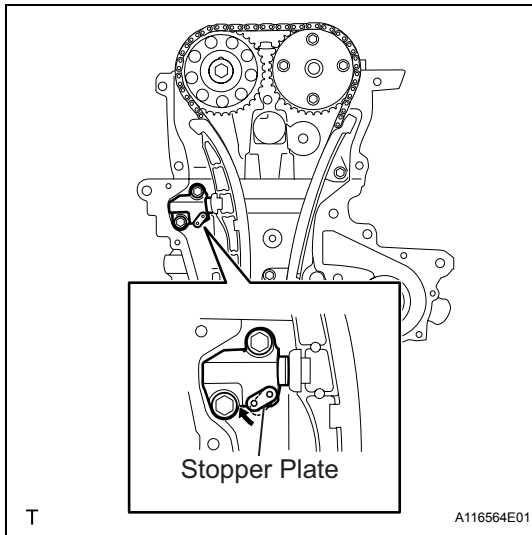

- (b) Unlock the plunger of the tensioner and push it in to the end.

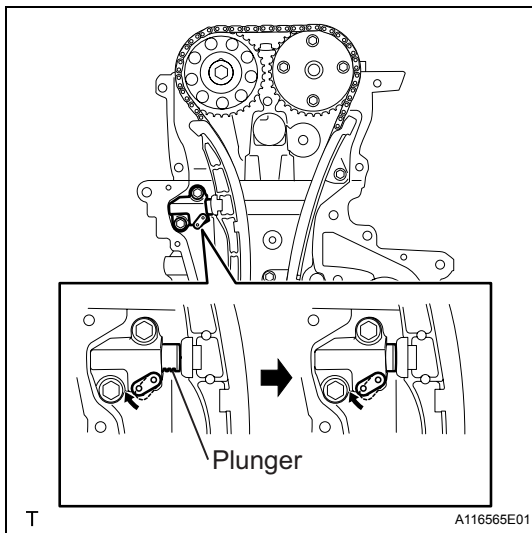

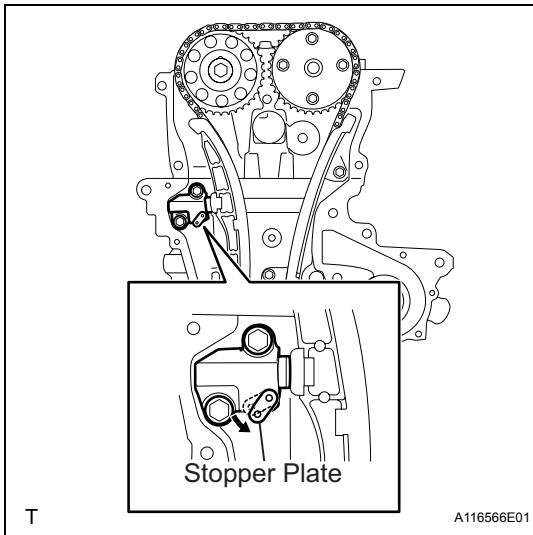

- (c) Pull down the stopper plate with the plunger pushed to the end and lock the plunger.

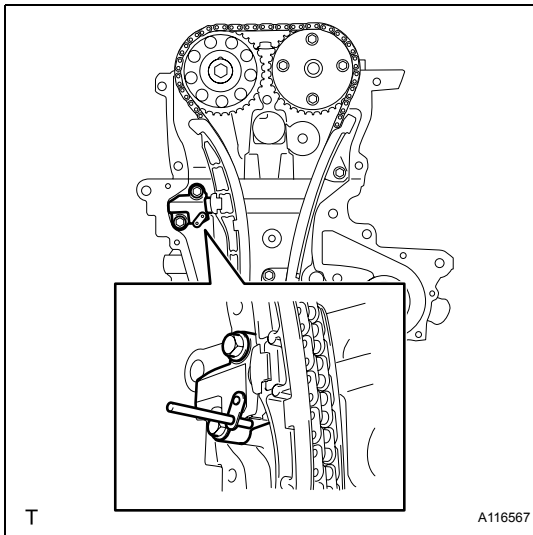

- (d) Insert a 3 mm (0.12 in.) diameter bar into the hole in the stopper plate and lock the plunger.

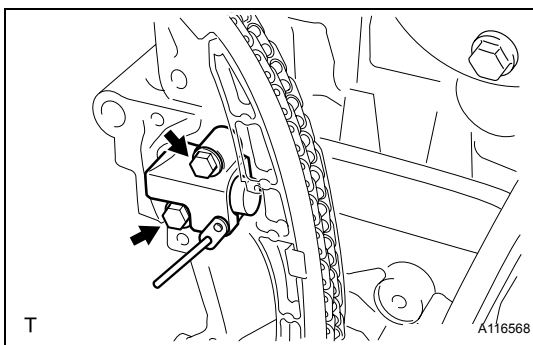

- (e) Remove the 2 bolts and remove chain tensioner assembly No. 1.

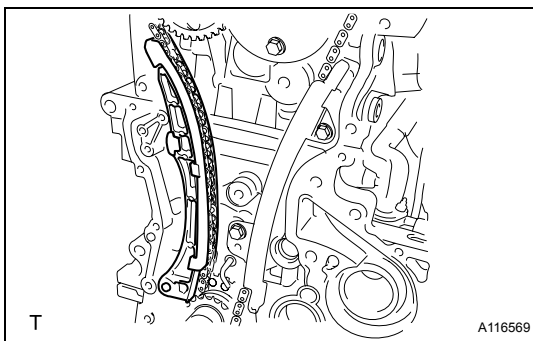

22. REMOVE CHAIN TENSIONER SLIPPER

- (a) Remove the chain tensioner slipper.

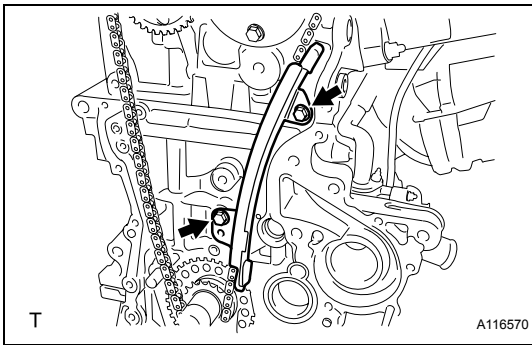
**23. REMOVE CHAIN VIBRATION DAMPER NO. 1**

- (a) Remove the 2 bolts and remove chain vibration damper No. 1.

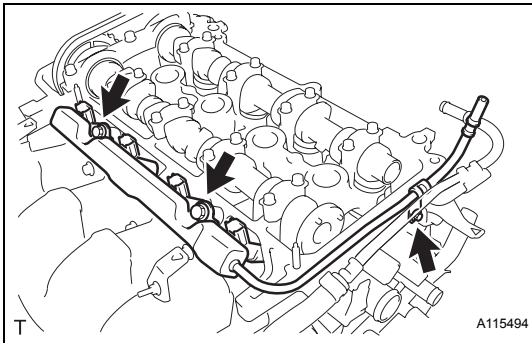
24. REMOVE CHAIN SUB-ASSEMBLY**25. REMOVE FUEL DELIVERY PIPE SUB-ASSEMBLY**

- (a) Remove the 3 bolts and remove the fuel delivery pipe sub-assembly with 4 fuel injectors.

NOTICE:

Do not drop the fuel injectors when removing the fuel delivery pipe sub-assembly.

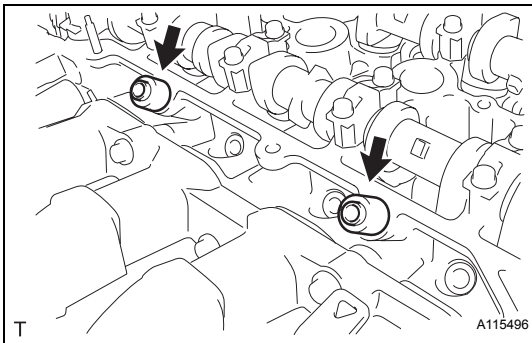
**26. REMOVE DELIVERY PIPE NO. 1 SPACER**

- (a) Remove the 2 delivery pipe No. 1 spacers.

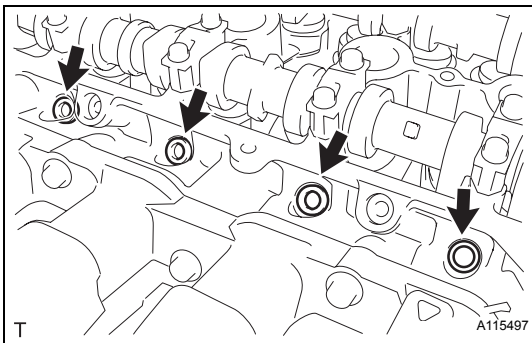
**27. REMOVE INJECTOR VIBRATION INSULATOR**

- (a) Remove the 4 injector vibration insulators.

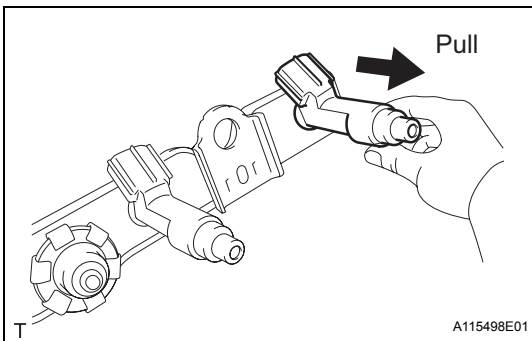
**28. REMOVE FUEL INJECTOR ASSEMBLY**

- (a) Pull the 4 fuel injector assemblies out of the fuel delivery pipe sub-assembly.

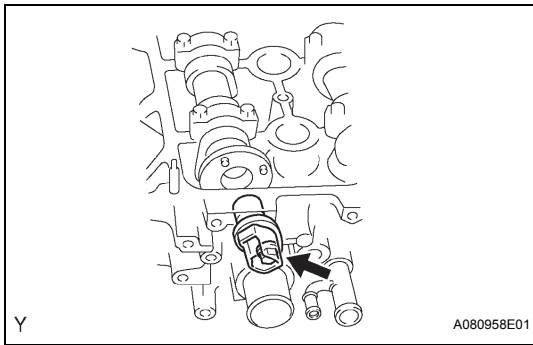
**29. REMOVE CAMSHAFT POSITION SENSOR**

- (a) Remove the bolt and the camshaft position sensor.

30. REMOVE NO. 2 CAMSHAFT**NOTICE:**

When rotating the camshaft with the timing chain removed, rotate the crankshaft counterclockwise 40° from the TDC first.

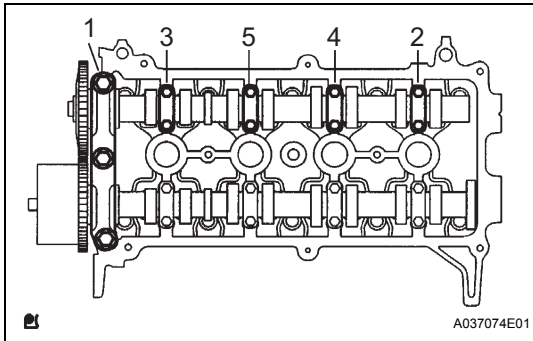

- (a) Using several steps, uniformly loosen and remove the 11 bearing cap bolts in the sequence shown in the illustration, then remove camshaft bearing cap No. 1, camshaft bearing cap No. 2 and camshaft No. 2.

NOTICE:

Loosen each bolt uniformly while keeping the camshaft level.

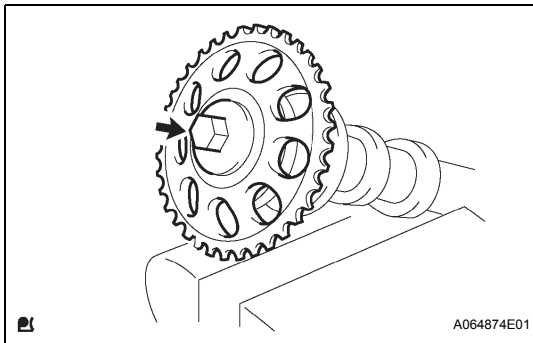
**31. REMOVE CAMSHAFT TIMING SPROCKET**

- (a) Clamp the camshaft in a vice.
 (b) Remove the flange bolt and the camshaft timing sprocket.

NOTICE:

Do not damage the camshaft.

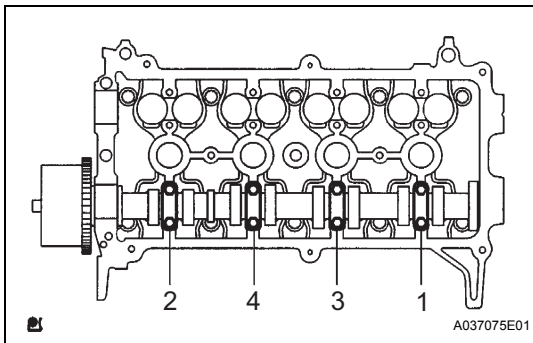
**32. REMOVE CAMSHAFT**

- (a) Using several steps, uniformly loosen and remove the 8 bearing cap bolts in the sequence shown in the illustration, then remove camshaft bearing cap No. 2 and the camshaft.

NOTICE:

Loosen each bolt uniformly while keeping the camshaft level.

33. REMOVE CAMSHAFT TIMING GEAR ASSEMBLY

- (a) Clamp the camshaft in a vise, and confirm that it is locked.

NOTICE:

Do not damage the camshaft.

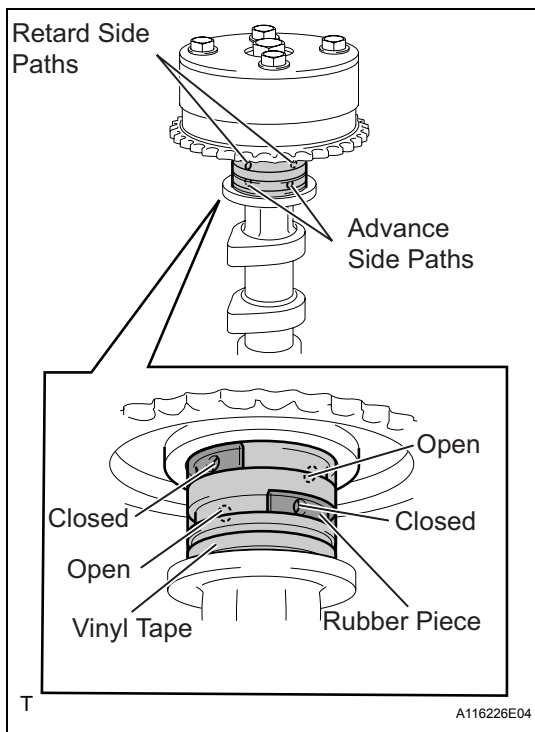

- (b) Cover the 4 oil paths of the cam journal with tape as shown in the illustration.

HINT:

One of the 2 grooves located on the cam journal is for retarding cam timing (upper) and the other is for advancing cam timing (lower). Each groove has 2 oil paths. Plug one of the oil paths for each groove with a piece of rubber before wrapping the cam journal with the tape.

- (c) Puncture the tape covering the advance oil path and the retard oil path on the opposite side from the advance oil path.

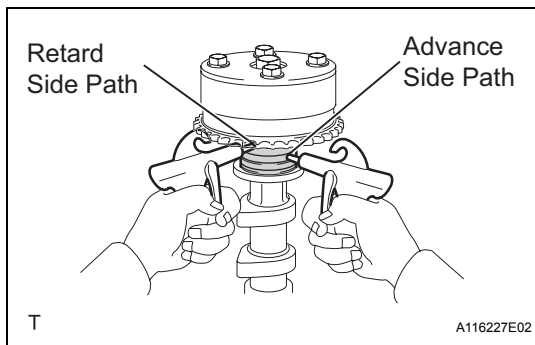

- (d) Apply about 150 kPa (1.5 kgf*cm²) air pressure into the 2 broken paths (the advance side path and the retard side path).

NOTICE:

Cover the paths with a shop rag or piece of cloth to prevent oil splashes.

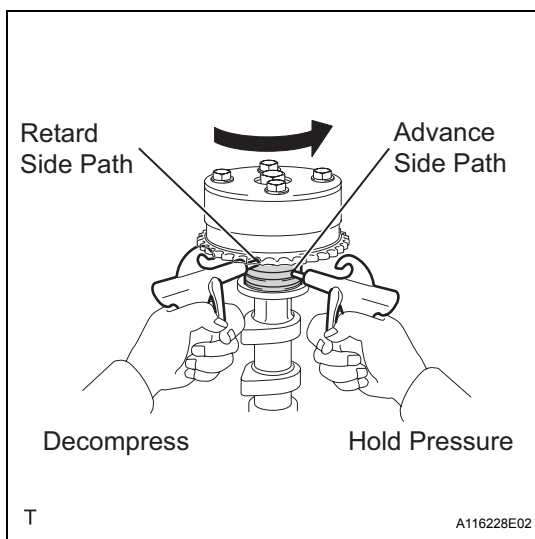

- (e) Confirm that the camshaft timing gear assembly revolves in the timing advance direction when the air pressure on the timing retard path is reduced.

HINT:

The lock pin is released and the camshaft timing gear revolves in the advance direction.

- (f) When the camshaft timing gear reaches the most advanced position, release the air pressure on the timing retard side path, and then release the air pressure on the timing advance side path.

NOTICE:

Camshaft timing gear assembly occasionally shifts to the retard side abruptly if the air pressure on the advance side path is released first. This often results in breakage of the lock pin.

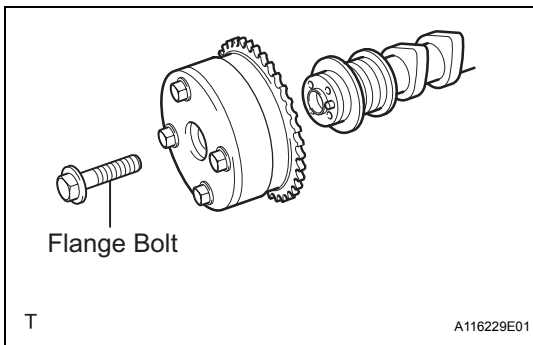

- (g) Remove the flange bolt and remove the camshaft timing gear assembly.

NOTICE:

- Do not remove the other 4 bolts.
- When reusing the camshaft timing gear, unlock the lock pin inside the camshaft timing gear first.

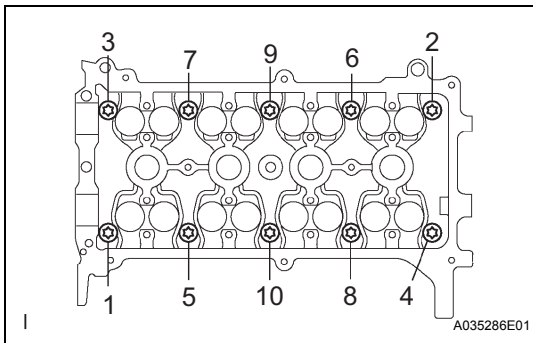
**34. REMOVE CYLINDER HEAD SUB-ASSEMBLY**

- (a) Using several steps, uniformly loosen and remove the 10 cylinder head bolts with an 8 mm bi-hexagon wrench in the sequence shown in the illustration. Remove the 10 cylinder head bolts and the plate washers.

NOTICE:

- Do not drop the washers into the cylinder head.
- Head warpage or cracking could result from removing bolts in the wrong order.

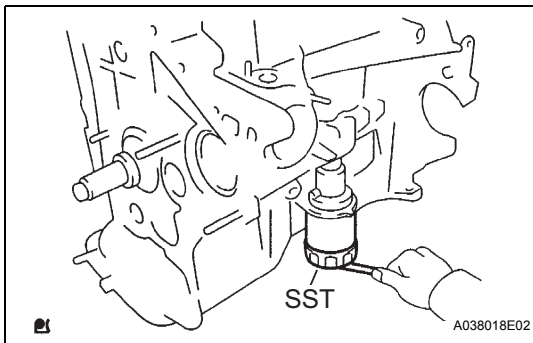
**35. REMOVE CYLINDER HEAD GASKET****36. REMOVE OIL FILTER SUB-ASSEMBLY**

- (a) Using SST, remove the oil filter.

SST 09228-06501

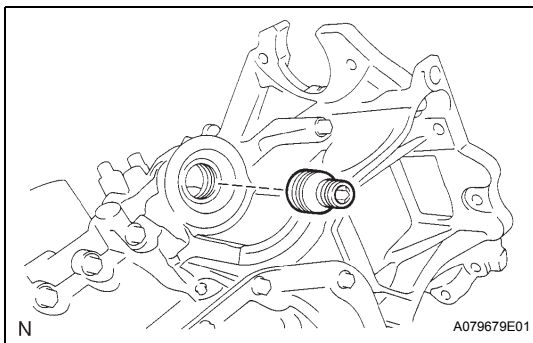
**37. REMOVE OIL FILTER UNION**

- (a) Using a 12 mm hexagon wrench, remove the oil filter union.

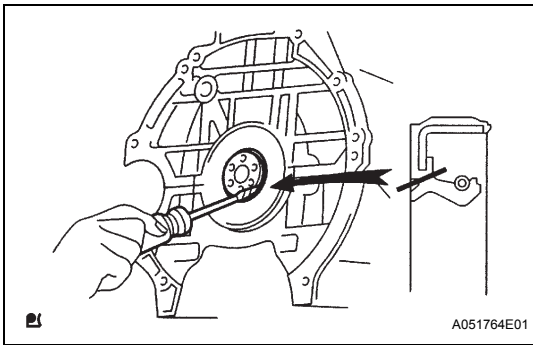
**38. REMOVE ENGINE REAR OIL SEAL**

- (a) Using a knife, cut off the oil seal lip.
- (b) Using a screwdriver with its tip wrapped in protective tape, pry out the oil seal.

NOTICE:

After removal, check the crankshaft for any damage. If damaged, smooth the surface with 400-grit sandpaper.

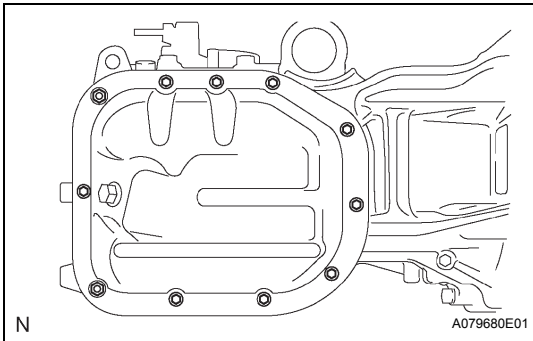
**39. REMOVE OIL PAN SUB-ASSEMBLY NO. 2**

- (a) Remove the oil pan drain plug and gasket.
- (b) Remove the 9 bolts and 2 nuts.

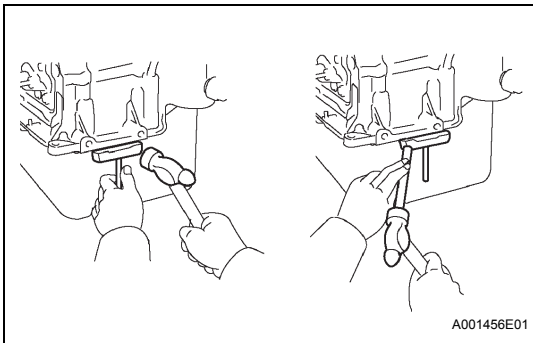

- (c) Insert the blade of SST between oil pan No. 1 and oil pan No. 2, and cut off the applied sealer and remove oil pan No. 2.

SST 09032-00100**NOTICE:**

Do not damage oil pan No. 1 or oil pan No. 2.

40. REMOVE OIL STRAINER SUB-ASSEMBLY

- (a) Remove the bolt and 2 nuts.
- (b) Remove the oil strainer and the gasket.

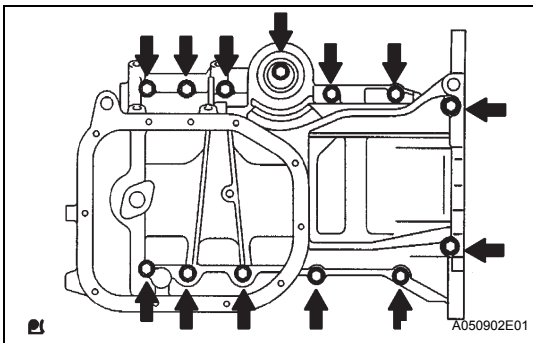
**41. REMOVE OIL PAN SUB-ASSEMBLY**

- (a) Loosen and remove the 13 bolts uniformly in several steps.

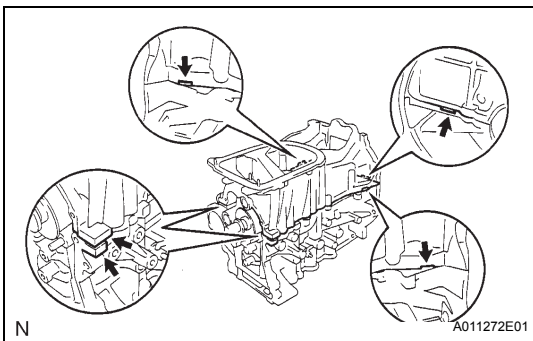

- (b) Using a screwdriver, remove oil pan No. 1 by prying between the cylinder block and oil pan No. 1.

NOTICE:

Do not damage the contact surfaces of oil pan No. 1 or the cylinder block.

- (c) Remove the 2 O-rings from the cylinder block.

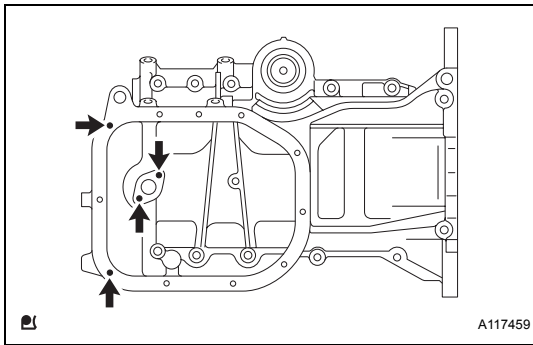
**42. REMOVE STUD BOLT**

- (a) Remove the 4 stud bolts.

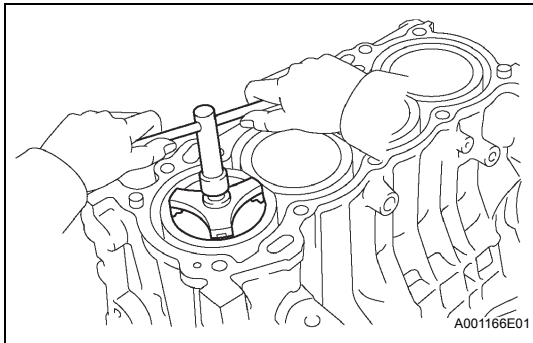
**43. REMOVE PISTON SUB-ASSEMBLY WITH CONNECTING ROD**

- (a) Using a ridge reamer, remove all the carbon from the top of the cylinder.
 (b) Push the piston, connecting rod assembly and upper bearing down through the top of the cylinder block to remove them.

HINT:

- Keep the bearing, connecting rod and cap together.
- Keep the piston and the connecting rod assemblies in the correct order so that they can be returned to their original locations when reassembled.

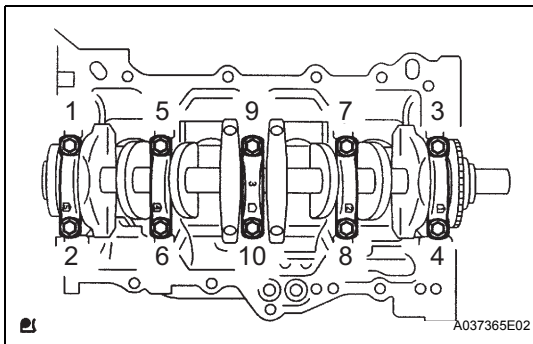
**44. REMOVE CONNECTING ROD BEARING****45. REMOVE CRANKSHAFT**

- (a) Using several steps, loosen and remove the 10 bearing cap sub-assembly bolts uniformly with SST in the sequence shown in the illustration.

SST 09011-38121

- (b) Remove the bearing cap and the crankshaft.

46. REMOVE CRANKSHAFT BEARING**47. REMOVE CRANKSHAFT THRUST WASHER UPPER****48. REMOVE PISTON RING SET****NOTICE:**

Keep the piston rings in the correct combination and correct order so that they can be returned to their original locations when reassembled.

- (a) Using a piston ring expander, remove the 2 compression rings.
 (b) Remove the 2 side rails and the oil ring by hand.

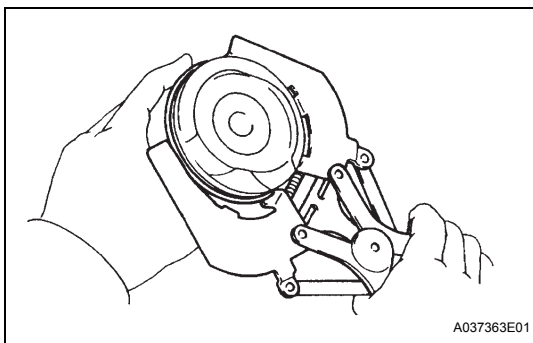

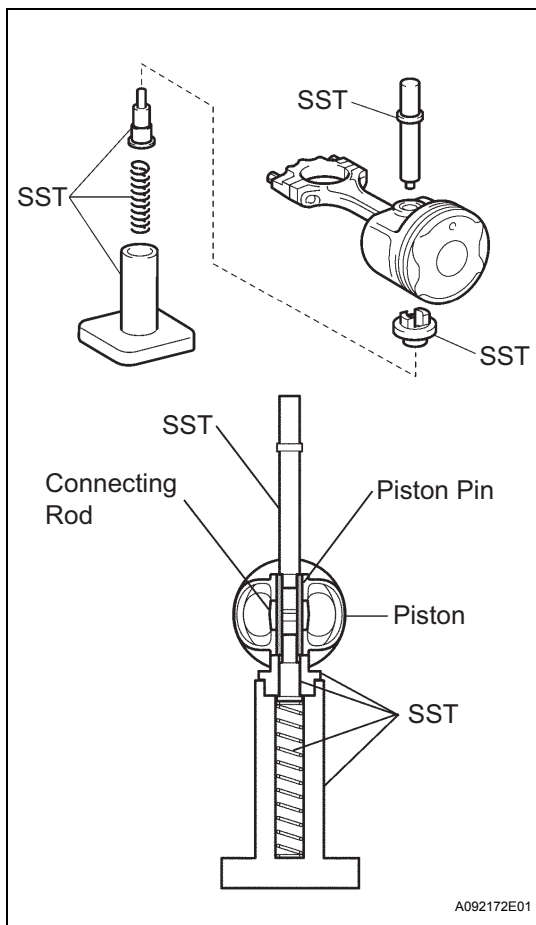
**49. REMOVE WITH PIN PISTON SUB-ASSEMBLY**

- (a) Using SST, press the piston pin out of the piston.
SST 09221-25026 (09221-00021, 09221-00030, 09221-00090, 09221-00150, 09221-00100)

NOTICE:

Keep the pistons, pins, rings, connecting rods and bearings in the correct order so that they can be returned to their original locations when reassembled.

50. REMOVE CYLINDER BLOCK WATER DRAIN COCK SUB-ASSEMBLY**51. REMOVE STUD BOLT**

- (a) Using "Torx" socket wrench E5, remove the 7 stud bolts.

52. REMOVE RING PIN**53. REMOVE STRAIGHT PIN**

EM

INSPECTION

1. INSPECT CAMSHAFT TIMING GEAR ASSEMBLY

- (a) Check the lock of camshaft timing gear.
 (1) Clamp the camshaft in a vice, and check that the camshaft timing gear is locked.

NOTICE:

Do not damage the camshaft.

- (b) Release the lock pin.

- (1) Cover the 4 oil paths of the cam journal with tape as shown in the illustration.

HINT:

One of the 2 grooves located on the cam journal is for retarding cam timing (upper) and the other is for advancing cam timing (lower). Each groove has 2 oil paths. Plug one of the oil paths for each groove with a piece of rubber before wrapping the cam journal with the tape.

- (2) Puncture the tape covering the advance oil path and the retard oil path on the opposite side from the advance oil path.

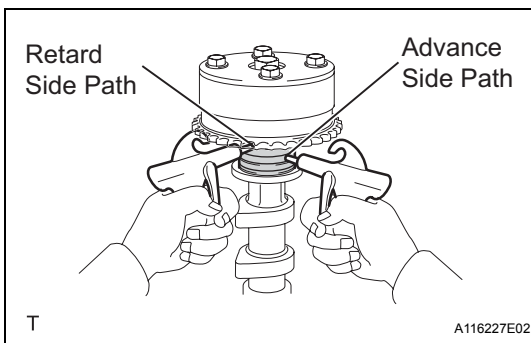
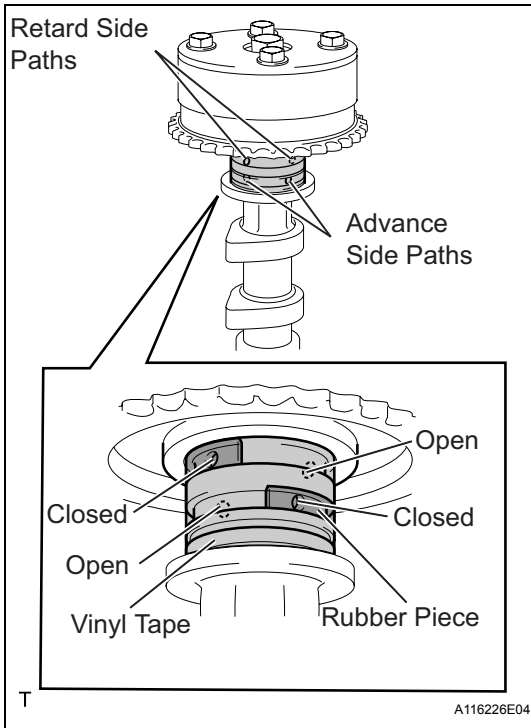

- (3) Apply air at about 150 kPa (1.5 kgf*cm²) pressure into the 2 broken paths (the advance side path and the retard side path).

NOTICE:

Cover the paths with a shop rag or piece of cloth to prevent oil splashes.

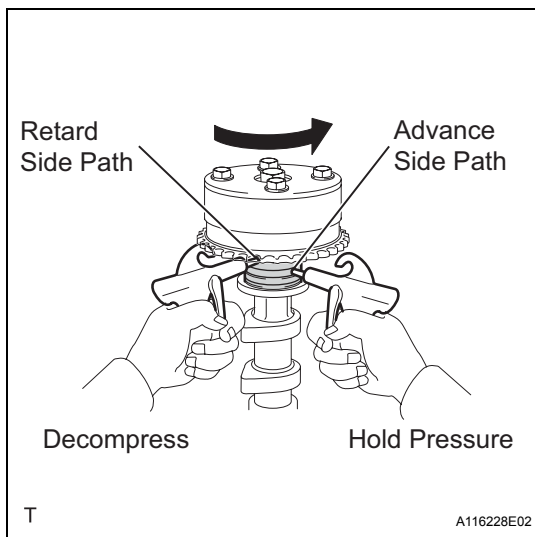

- (4) Confirm that the camshaft timing gear assembly revolves in the timing advance direction when the air pressure on the timing retard path is reduced.

HINT:

The lock pin is released and the camshaft timing gear revolves in the advance direction.

- (5) When the camshaft timing gear reaches the most advanced position, release the air pressure on the timing retard side path, and then release the air pressure on the timing advance side path.

NOTICE:

Camshaft timing gear assembly occasionally shifts to the retard side abruptly if the air pressure on the advance side path is released first. This often results in breakage of the lock pin.

- (c) Check that the revolution is smooth.
- (1) Rotate the valve timing assembly back and forth several times, except where the lock pin meets it at the most retarded angle. Check the movable range and that it rotates smoothly.

Standard:

Smooth movable range is about 22.5°

NOTICE:

Perform this check by hand, instead of using air pressure.

- (d) Check that the gear locks in the most retarded position.

- (1) Confirm that the camshaft timing gear assembly is locked in the most retarded position.

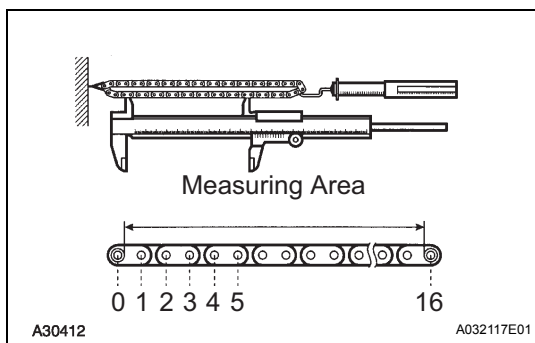

2. INSPECT CHAIN SUB-ASSEMBLY

- (a) Using a spring scale, apply 140 N (14.3 kgf, 31.5 lb) to the timing chain and measure its length.

Maximum chain elongation:

123.2 mm (4.850 in.)

If the elongation is greater than the maximum, replace the chain.

HINT:

Perform the same measurement at 3 or more random places and calculate the average length.

3. INSPECT CHAIN TENSIONER ASSEMBLY NO. 1

- (a) Check that the plunger moves smoothly when the ratchet pawl is raised with your finger.
- (b) Release the ratchet pawl and check that the plunger is locked in place by the ratchet pawl and does not move when pushed with your finger.

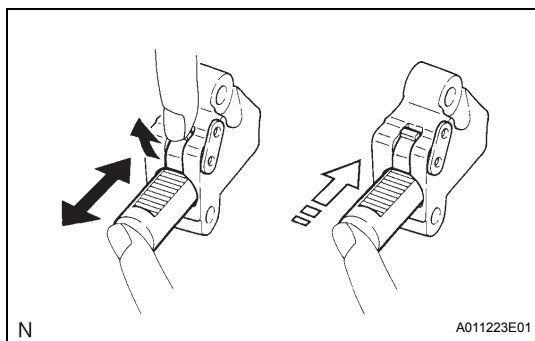

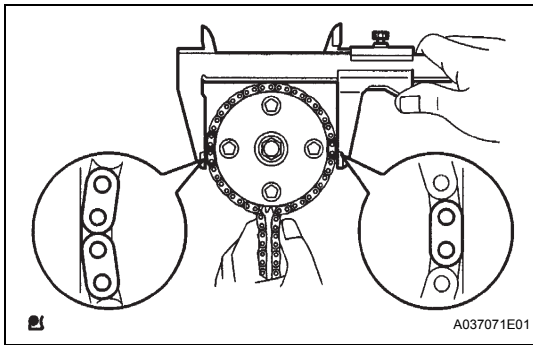
**4. INSPECT CAMSHAFT TIMING GEAR ASSEMBLY**

- (a) Wrap the chain around the timing sprocket.
- (b) Using vernier calipers, measure the diameter of the timing gear with the chain.

Minimum gear diameter (with chain):

96.2 mm (3.787 in.)

If the diameter is less than the minimum, replace the camshaft timing gear.

NOTICE:

Make sure that the vernier calipers are in contact with the chain link when measuring.

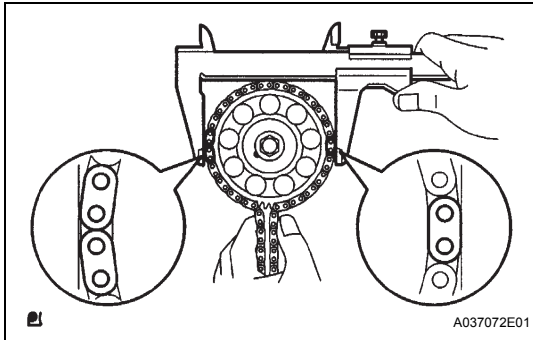
**5. INSPECT CAMSHAFT TIMING SPROCKET**

- (a) Wrap the chain around the timing sprocket.
- (b) Using vernier calipers, measure the diameter of the timing gear with the chain.

Minimum gear diameter (with chain):

96.2 mm (3.787 in.)

If the diameter is less than the minimum, replace the camshaft timing sprocket.

NOTICE:

Make sure that the vernier calipers are in contact with the chain link when measuring.

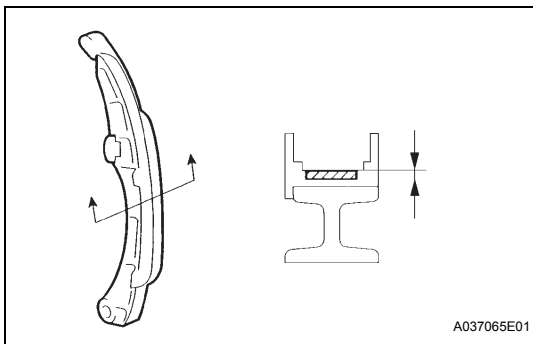
**6. INSPECT CHAIN TENSIONER SLIPPER**

- (a) Check the chain tensioner slipper.

Minimum thickness:

1.0 mm (0.039 in.)

If the thickness is less than the minimum, replace the chain tensioner slipper.

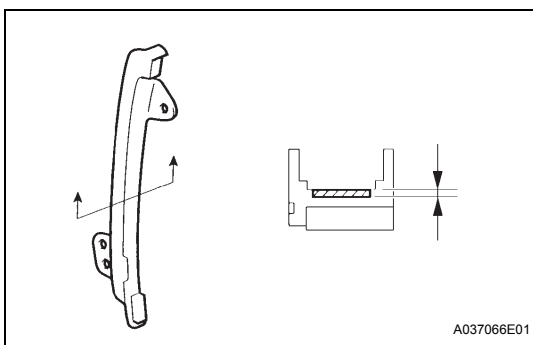
**7. INSPECT CHAIN VIBRATION DAMPER NO. 1**

- (a) Check the vibration damper.

Minimum thickness:

1.0 mm (0.039 in.)

If the thickness is less than the minimum, replace the chain vibration damper.

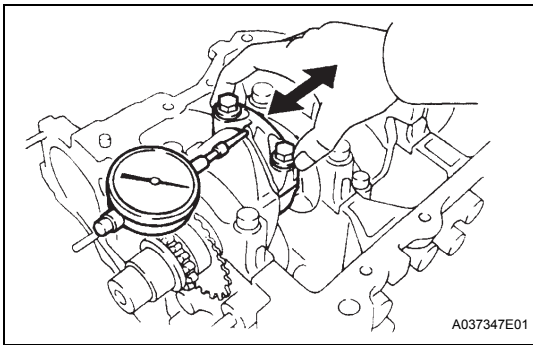

8. INSPECT CONNECTING ROD THRUST CLEARANCE

- (a) Using a dial indicator, measure the thrust clearance while moving the connecting rod back and forth.

Standard thrust clearance:

0.16 to 0.36 mm (0.0063 to 0.0142 in.)

Maximum thrust clearance:

0.36 mm (0.0142 in.)

9. INSPECT CONNECTING ROD OIL CLEARANCE

- (a) Check that the matchmarks on the connecting rod and cap are aligned to ensure correct reassembly.

- (b) Using SST, remove the 2 connecting rod cap bolts.

SST 09205-16010

- (c) Clean the crank pin and bearing.

- (d) Check the crank pin and bearing for pitting and scratches.

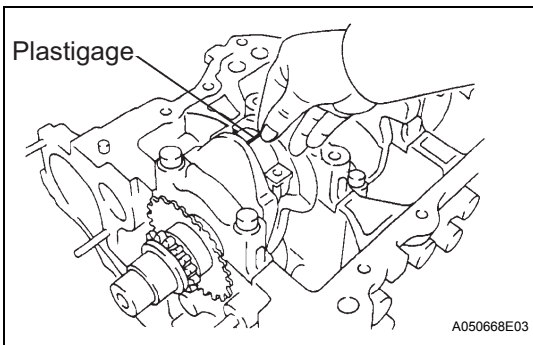
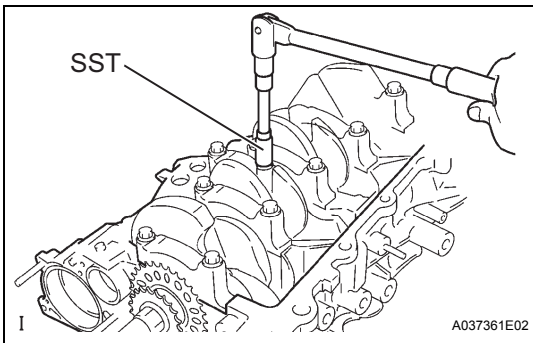

- (e) Lay a strip of Plastigage across the crank pin.

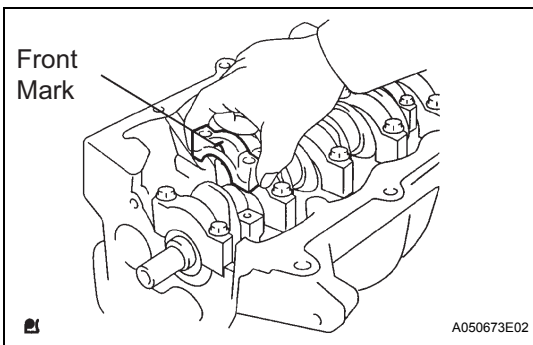

- (f) Make sure that the connecting rod and its cap are in the correct combination and that the front mark of the cap is facing in the correct mounting orientation, then install the cap onto the connecting rod.

- (g) Apply a light coat of engine oil to the threads of the connecting rod cap bolts.

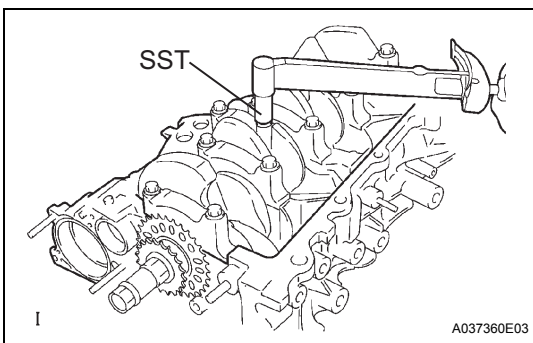

- (h) Using SST, tighten the bolts in several steps to the specified torque.

SST 09205-16010

Torque: 15 N*m (153 kgf*cm, 11 ft.*lbf)

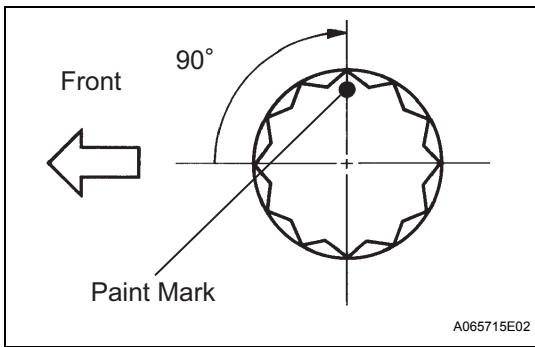

- (i) Mark the front of the connecting cap bolts with paint.
- (j) Retighten the cap bolts by 90° as shown in the illustration.

NOTICE:
Do not turn the crankshaft.

- (k) Remove the 2 bolts, connecting rod cap and lower bearing.

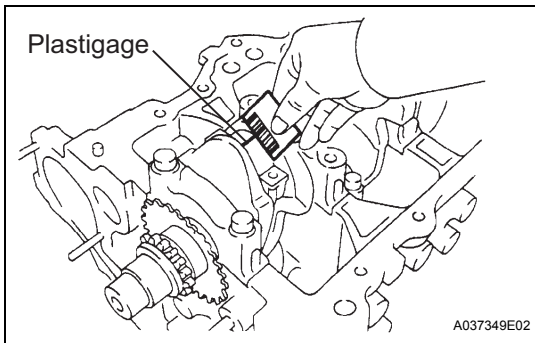

- (l) Measure the Plastigage at its widest point.

Standard oil clearance:

0.012 to 0.038 mm (0.00047 to 0.00015 in.)

Maximum oil clearance:

0.058 mm (0.0028in.)

NOTICE:

Completely remove the Plastigage after the measurement.

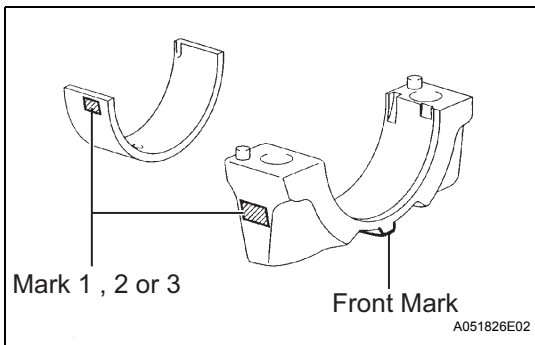

- (m) When replacing a bearing, replace it with one with the same number as marked on the connecting rod. There are 3 sizes of standard bearings, marked 1, 2 and 3 accordingly.

Standard bearing center wall thickness

Mark	mm (in.)
1	1.491 to 1.494 (0.0587 to 0.0588)
2	1.494 to 1.497 (0.0588 to 0.0589)
3	1.497 to 1.500 (0.0589 to 0.0591)

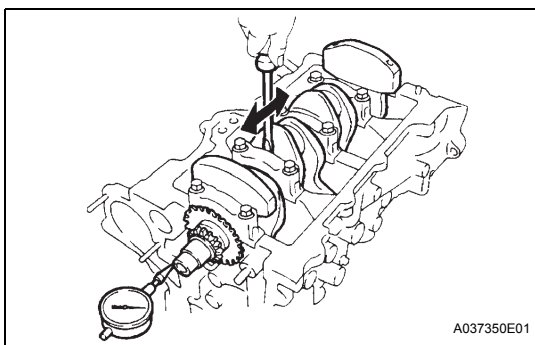

10. INSPECT CRANKSHAFT THRUST CLEARANCE

- (a) Using a dial indicator, measure the thrust clearance while moving the crankshaft back and forth with a screwdriver.

Standard thrust clearance:

0.09 to 0.19 mm (0.0035 to 0.0075 in.)

Maximum thrust clearance:

0.30 mm (0.0118 in.)

If the thrust clearance is greater than the maximum, replace the thrust washers as a set. Check the crankshaft and block for wear. Repair or replace the parts if necessary.

HINT:

Thrust washer thickness: 2.43 to 2.48 mm (0.0957 to 0.976 in.)

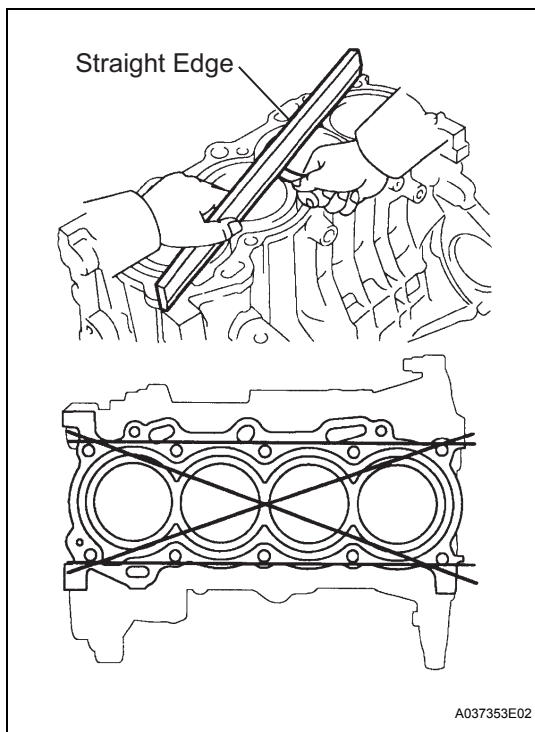

11. INSPECT CYLINDER BLOCK FOR WARPAGE

- (a) Using a precision straight edge and feeler gauge, measure the warpage of the surface which is in contact with the cylinder head gasket.

Maximum warpage:

0.05 mm (0.0020 in.)

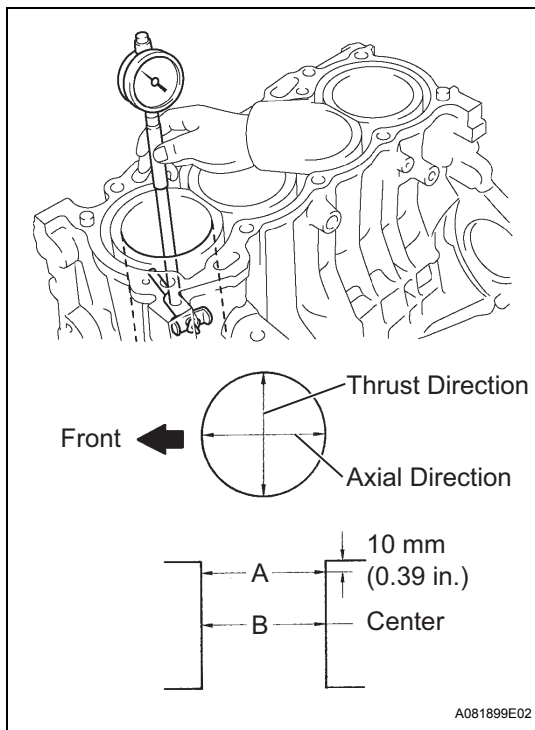

12. INSPECT CYLINDER BORE

- (a) Using a cylinder gauge, measure the cylinder bore diameter at positions A and B in both the thrust and axial directions.

Standard Inside diameter:

75.000 to 75.013 mm (2.9528 to 2.9533 in.)

- (b) Calculate the difference between the maximum diameter and the minimum diameter of the 4 measured values.

Difference limit:

0.10 mm (0.0039 in.)

If the difference is greater than the limit, replace the cylinder block.

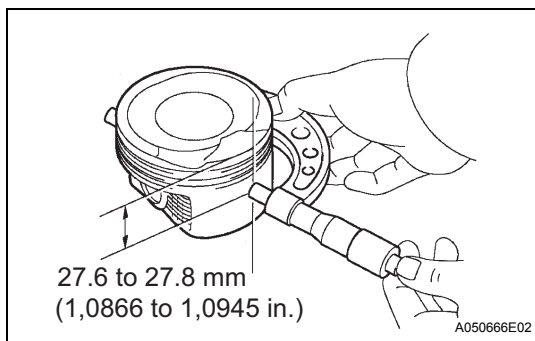

13. INSPECT WITH PIN PISTON SUB-ASSEMBLY

- (a) Using a micrometer, measure the piston diameter at a right angle to the piston pin center line, and at the position 27.6 to 27.8 mm (1.0866 to 1.0945 in.) from the top of the piston head.

Piston diameter:

74.935 to 74.945 mm (2.9502 to 2.9506 in.)

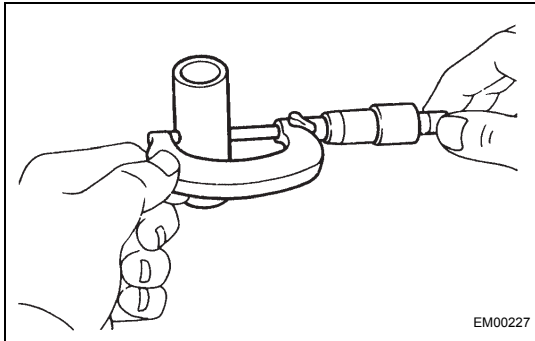

- (b) Using a caliper gauge, measure the piston pin hole diameter.

Piston pin hole diameter:

18.013 to 18.016 mm (0.7092 to 0.7093 in.) at 20°C (68°F)

- (c) Using a micrometer, measure the piston pin diameter.

Piston pin diameter:

18.001 to 18.004 mm (0.7087 to 0.7088 in.)

- (d) Subtract the piston pin diameter measurement from the piston pin hole diameter measurement to calculate the oil clearance.

Standard oil clearance:

0.009 to 0.015 mm (0.0004 to 0.0006 in.)

Maximum oil clearance:

0.050 mm (0.0020 in.)

If necessary, replace the piston and piston pin together.

EM

14. INSPECT PISTON CLEARANCE

- (a) Subtract the piston diameter measurement from the cylinder bore diameter measurement.

Standard oil clearance:

0.045 to 0.068 mm (0.0018 to 0.0027 in.)

Maximum oil clearance:

0.08 mm (0.0032 in.)

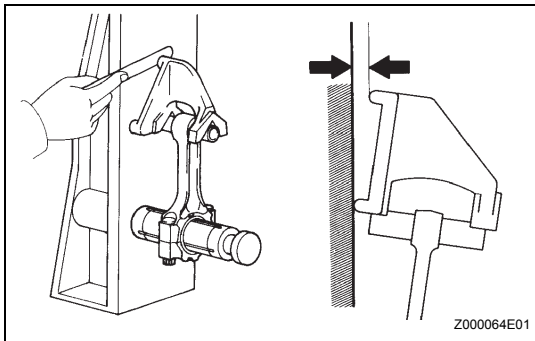

15. INSPECT CONNECTING ROD SUB-ASSEMBLY

- (a) Using a rod aligner and feeler gauge, check the connecting rod alignment.

- (1) Check for misalignment.

Maximum misalignment:

0.05 mm (0.0020 in.) per 100 mm (3.94 in.)

If the misalignment is greater than the maximum, replace the connecting rod assembly.

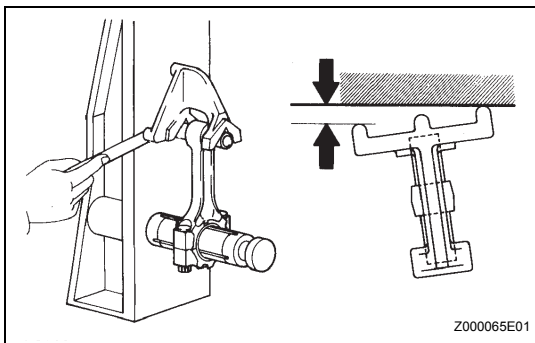

- (2) Check for twist.

Maximum twist:

0.05 mm (0.0020 in.) per 100 mm (3.94 in.)

If the twist is greater than the maximum, replace the connecting rod assembly.

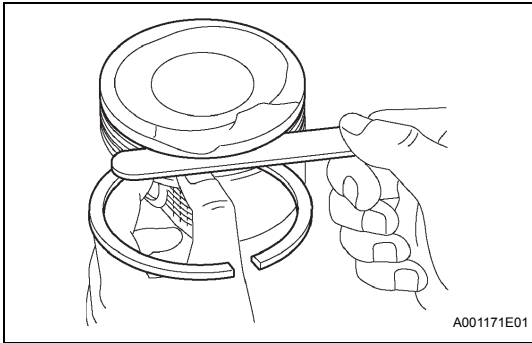
**16. INSPECT RING GROOVE CLEARANCE**

- (a) Using a feeler gauge, measure the clearance between a new piston ring and the wall of the ring groove.

Ring groove clearance:

No. 1:

0.03 to 0.07 mm (0.0012 to 0.0028 in.)

No. 2:

0.02 to 0.06 mm (0.0008 to 0.0024 in.)

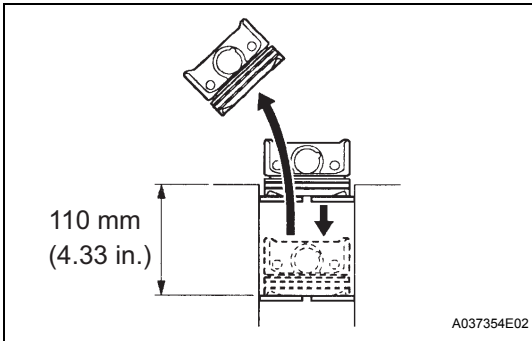
**17. INSPECT PISTON RING END GAP**

- (a) Using a piston, push the piston ring, a little beyond the bottom of the ring travel, 110 mm (4.33 in.) from the top of the cylinder block.

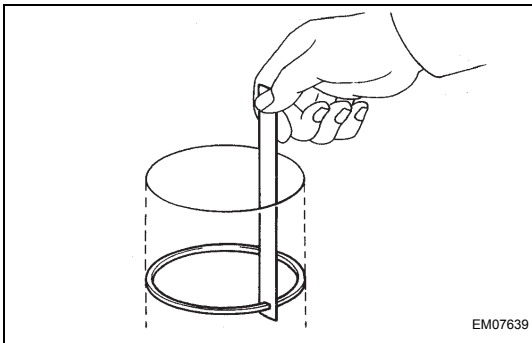

- (b) Using a feeler gauge, measure the end gap.

Standard end gap:

No. 1:

0.25 to 0.35 mm (0.0098 to 0.0138 in.)

No. 2:

0.35 to 0.50 mm (0.0138 to 0.0197 in.)

Oil (Side Rail):

0.10 to 0.35 mm (0.0039 to 0.0138 in.)

Maximum end gap:

No. 1:

0.91 mm (0.0358 in.)

No. 2:

1.06 mm (0.0417 in.)

Oil (Side Rail):

0.82 mm (0.323 in.)

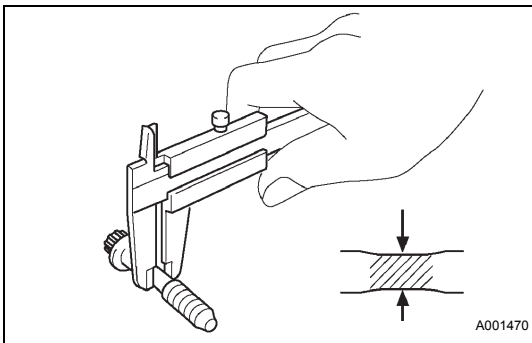
**18. INSPECT CONNECTING ROD BOLT**

- (a) Using vernier calipers, measure the diameter of the bolt at the elongated portion.

Standard diameter:

6.6 to 6.7 mm (0.260 to 0.264 in.)

Minimum diameter:

6.4 mm (0.252 in.)

If the diameter is less than the minimum, replace the bolt.

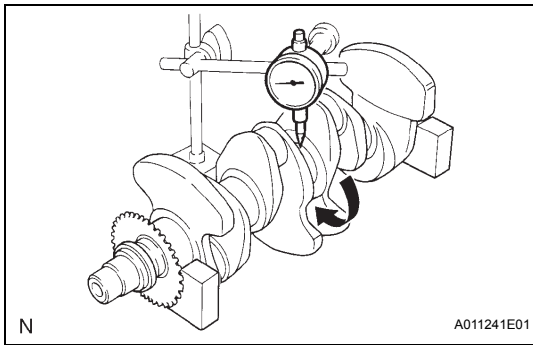
**19. INSPECT CRANKSHAFT**

- (a) Using a dial indicator and V-blocks, measure the circle runout as shown in the illustration.

Maximum circle runout:
0.03 mm (0.0012 in.)

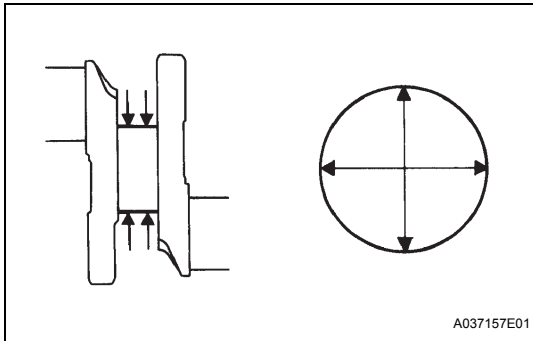

- (b) Using a micrometer, measure the diameter of each main journal.

Outside diameter:
45.988 to 46.000 mm (1.8106 to 1.8110 in.)

- (c) Check each main journal for taper and out-of-roundness as shown.

Maximum taper and out-of-roundness:
0.02 mm (0.0008 in.)

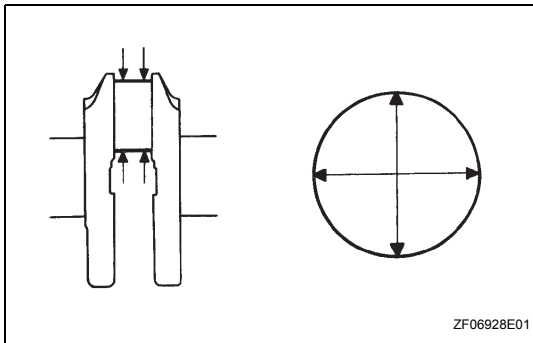

- (d) Using a micrometer, measure the diameter of each crank pin.

Outside diameter:
39.992 to 40.000 mm (1.5745 to 1.5748 in.)

- (e) Check each crank pin for taper and out-of-roundness as shown.

Maximum taper and out-of-roundness:
0.02 mm (0.0008 in.)

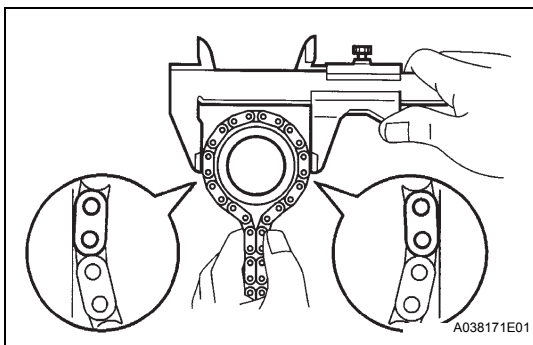

- (f) Wrap the chain around the timing sprocket.
 (g) Using vernier calipers, measure the timing sprocket diameter with the chain.

Standard sprocket diameter (with chain):
51.72 mm (2.0362 in.)

Minimum sprocket diameter (with chain):
50.5 mm (1.988 in.)

NOTICE:

Make sure that the vernier calipers are in contact with the chain rollers when measuring.

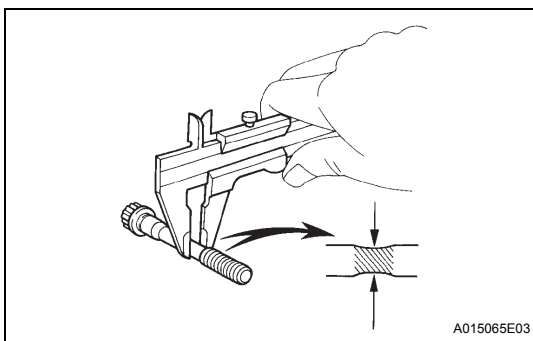
**20. INSPECT CRANKSHAFT BEARING CAP SET BOLT**

- (a) Using vernier calipers, measure the tension portion diameter of the elongated portion.

Standard diameter:
7.3 to 7.5 mm (0.287 to 0.295 in.)

Minimum diameter:
7.2 mm (0.283 in.)

If the diameter is less than the minimum, replace the bolt.

21. INSPECT CRANKSHAFT OIL CLEARANCE

- (a) Clean each main journal and bearing.
- (b) Install the bearing onto the cylinder block and bearing cap. (See page [EM-183](#))
- (c) Place the crankshaft onto the cylinder block.
- (d) Lay a strip of Plastigage across each journal.

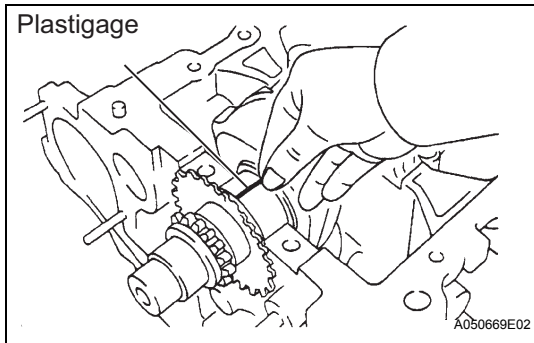

**Bearing
Cap No. 3:**

**Bearing Cap
No. 1, 2, 4, 5:**

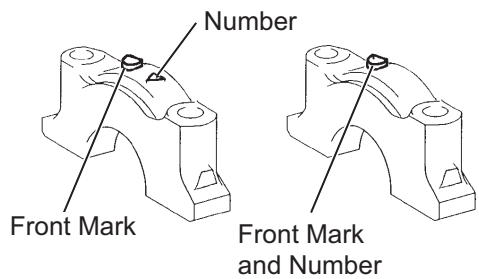

- (e) Examine the front marks and numbers and install the bearing cap onto the cylinder block.
- (f) Apply a light coat of engine oil to the threads of the bearing cap bolts.

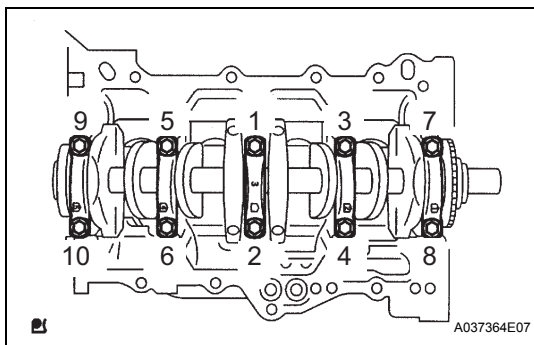

- (g) Using SST, tighten the bolts in several steps to the specified torque in the sequence shown in the illustration. (*1)

SST 09011-38121

Torque: 22 N*m (224 kgf*cm, 16 ft.*lbf)

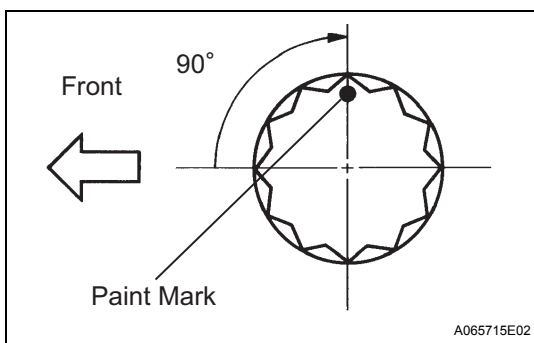

- (h) Mark the front of the bearing cap bolts with paint.
- (i) Retighten the bearing cap bolts by 90° in the same sequence as step (*1).
- (j) Check that the painted mark is now at a 90° angle from the front.

NOTICE:

Do not turn the crankshaft.

- (k) Remove the bearing cap sub-assembly.

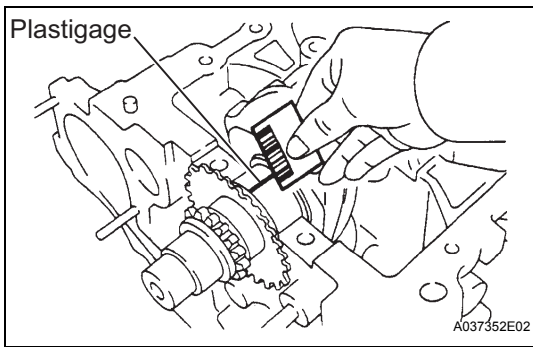

- (l) Measure the Plastigage at its widest point.
Standard oil clearance:
 0.01 to 0.023 mm (0.0004 to 0.0009 in.)
Maximum oil clearance:
 0.07 mm (0.0028 in.)

NOTICE:
Completely remove the Plastigage after the measurement.

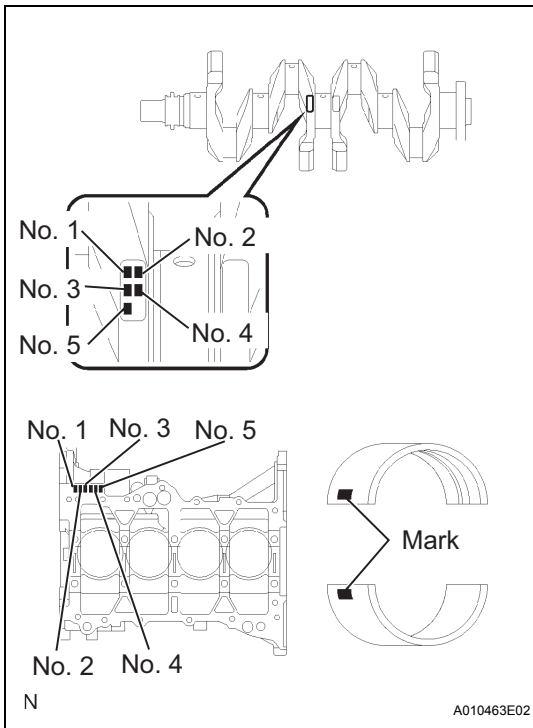

- (m) When replacing a standard bearing, replace it with one with the same number. If the number of the bearing cannot be found, select the correct bearing by adding together the numbers imprinted on the cylinder block and crankshaft, then select the bearing with the same number as the total. There are 4 sizes of standard bearings, marked 1, 2, 3 and 4 accordingly.

EXAMPLE: Cylinder Block 4 (A) + Crankshaft 3 (B) = Total 7 (Use Bearing 3)

Cylinder Block (A) +	0 to 2	3 to 5	6 to 8	9 to 11
Crankshaft (B)				
Use Bearing	1	2	3	4

Item	Mark	mm (in.)
Cylinder block main journal bore diameter (A)	0	50.000 to 50.003 (1.96850 to 1.96862)
	1	50.003 to 50.005 (1.96862 to 1.96870)
	2	50.005 to 50.007 (1.96870 to 1.96878)
	3	50.007 to 50.010 (1.96878 to 1.96890)
	4	50.010 to 50.012 (1.96890 to 1.96898)
	5	50.012 to 50.014 (1.96898 to 1.96906)
	6	50.014 to 50.016 (1.96906 to 1.96913)
Crankshaft main journal diameter (B)	0	45.998 to 46.000 (1.81094 to 1.81102)
	1	45.996 to 45.998 (1.81087 to 1.81094)
	2	45.994 to 45.996 (1.81079 to 1.81087)
	3	45.992 to 45.994 (1.81071 to 1.81079)
	4	45.990 to 45.992 (1.81063 to 1.81071)
	5	45.988 to 45.990 (1.81055 to 1.81063)
Standard bearing center wall thickness	1	1.992 to 1.995 (0.07843 to 0.07854)
	2	1.995 to 1.998 (0.07854 to 0.07866)
	3	1.998 to 2.001 (0.07866 to 0.07878)
	4	2.001 to 2.004 (0.07878 to 0.07890)

REASSEMBLY

1. INSTALL CYLINDER BLOCK WATER DRAIN COCK SUB-ASSEMBLY

(a) Apply adhesive to the end 2 or 3 threads of the drain union and install the water drain cock within 3 minutes of applying the adhesive.

(b) After applying the specified torque, rotate the drain union clockwise until its drain port faces downward.

Torque: 35 N*m (357 kgf*cm, 26 ft.*lbf)

NOTICE:

- Do not add coolant within 1 hour of installation.
- Do not rotate the drain union more than 360° in step (b), and never loosen it after setting the union correctly.

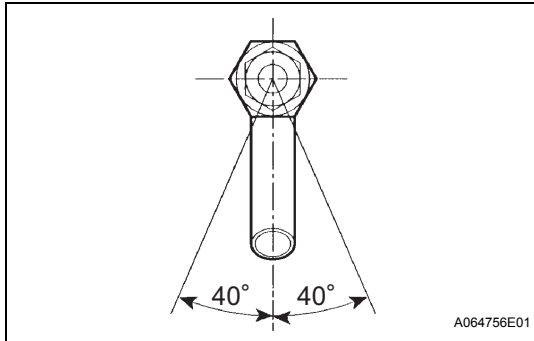

2. INSTALL STRAIGHT PIN

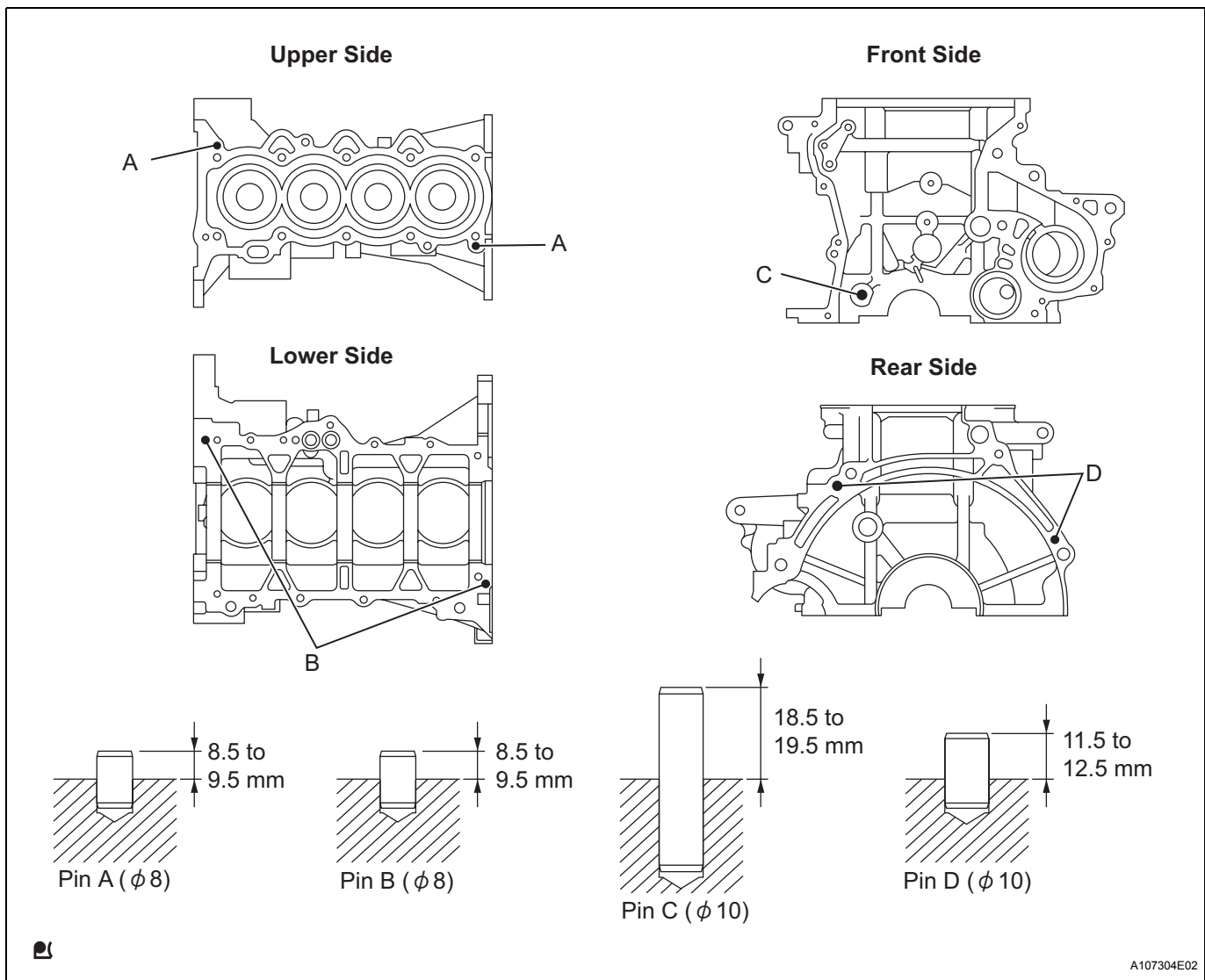

(a) Using a plastic-faced hammer, tap in the straight pin.

Standard protrusion:

Pin A:

8.5 to 9.5 mm (0.335 to 0.374 in.)

Pin B:

8.5 to 9.5 mm (0.335 to 0.374 in.)

Pin C:

18.5 to 19.5 mm (0.728 to 0.768 in.)

Pin D:

11.5 to 12.5 mm (0.453 to 0.492 in.)

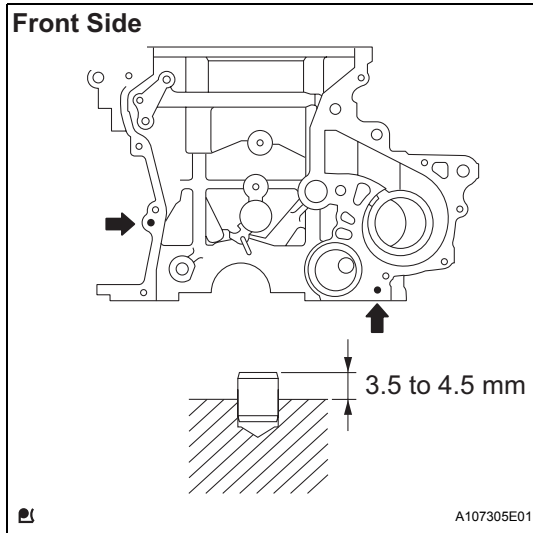

3. INSTALL OIL PUMP SET RING PIN

- (a) Using a plastic-faced hammer, tap in a new ring pin.

Standard protrusion:

3.5 to 4.5 mm (0.138 to 0.177 in.)

4. INSTALL STUD BOLT

EM

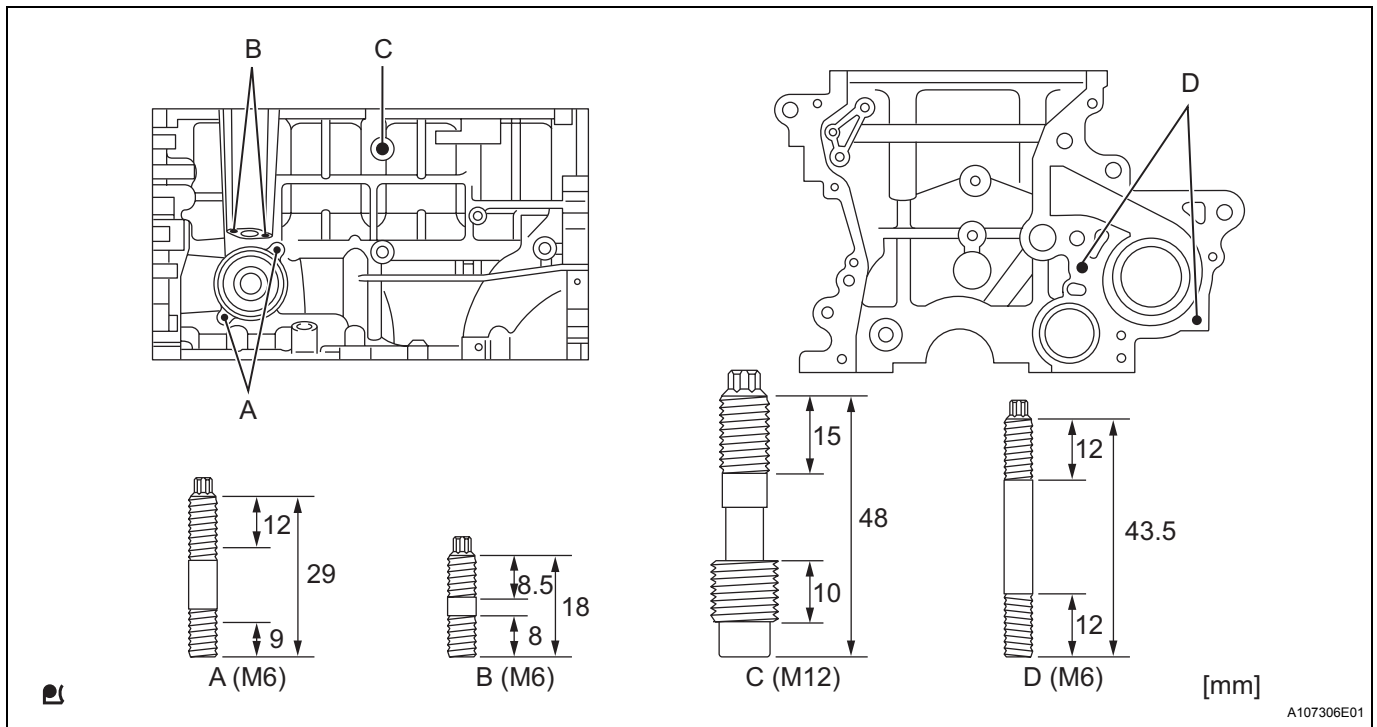

- (a) Using "Torx" socket wrench E5, install the 7 stud bolts.

Torque: 5.0 N*m (51 kgf*cm, 44 in.*lbf) (for Stud bolt A, B and D)

11 N*m (112 kgf*cm, 8.1 ft.*lbf) (for Stud bolt C)

NOTICE:

The lower threads of the bolt are installed into the cylinder block.

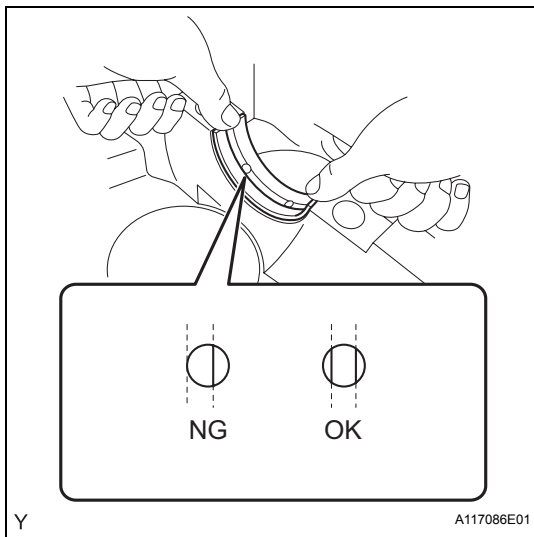

5. INSTALL CRANKSHAFT BEARING

- (a) Align the crankshaft bearing (upper) with the oil hole of the cylinder block and install the bearing.

NOTICE:

Do not apply engine oil to the bearing or its contact surface.

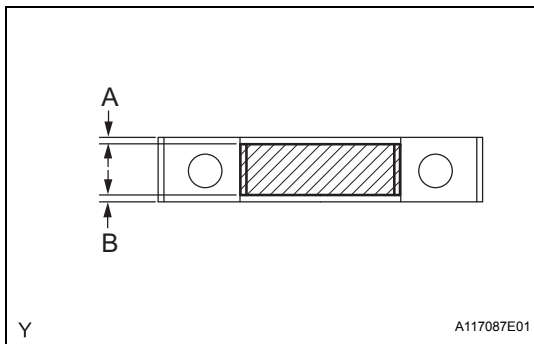

- (b) Align the crankshaft bearing (lower) with the bearing cap and install the crankshaft bearing cap.

NOTICE:

- Install the bearing cap so that the gap between A and B is less than 0.7 mm (0.028 in.).
- Do not apply engine oil to the bearing or its contact surface.

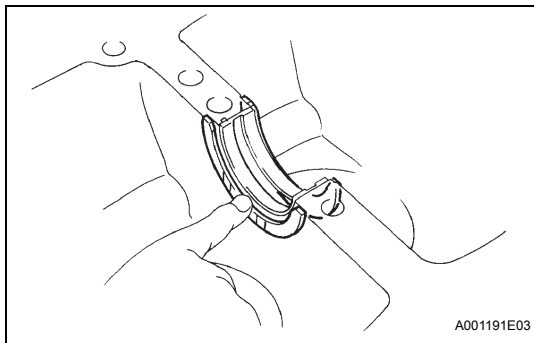

6. INSTALL CRANKSHAFT THRUST WASHER UPPER

- (a) Install the 2 thrust washers onto the No. 3 journal position of the cylinder block with the oil grooves facing outward.
- (b) Apply engine oil to the upper bearing and install the crankshaft onto the cylinder block.

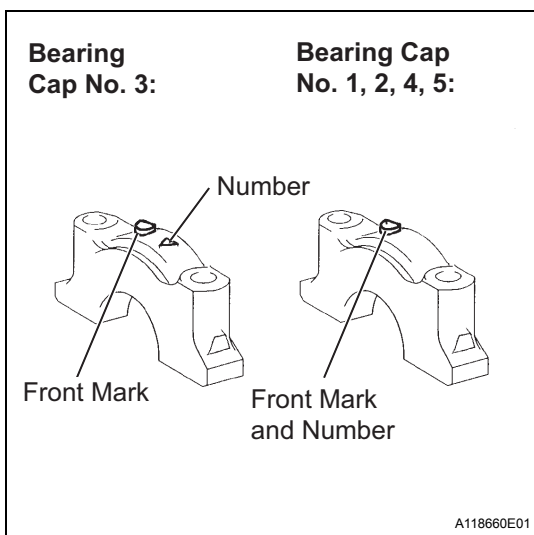

7. INSTALL CRANKSHAFT

- (a) Examine the front marks and numbers and install the bearing caps onto the cylinder block.
- (b) Apply a light coat of engine oil to the threads of the bearing cap bolts.

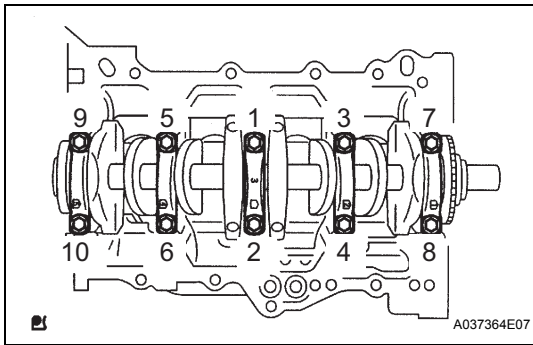

- (c) Using SST, tighten the bolts in several steps to the specified torque in the sequence shown in the illustration (*1).

SST 09011-38121

Torque: 22 N*m (224 kgf*cm, 16 ft.*lbf)

NOTICE:

Check that the crankshaft turns smoothly.

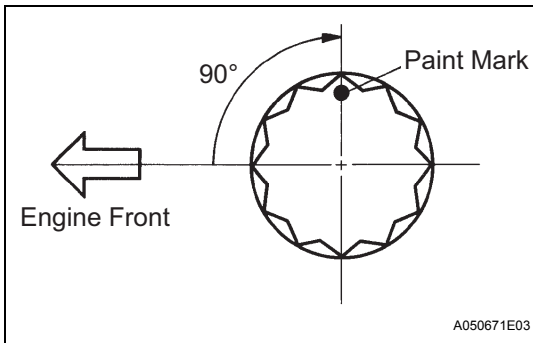

- (d) Mark the front of the bearing cap bolts with paint.
 (e) Retighten the bearing cap bolts by 90° in the same sequence as step (*1).
 (f) Check that the painted mark is now at a 90° angle from the front.

8. INSPECT CRANKSHAFT THRUST CLEARANCE (See page [EM-174](#))

9. INSPECT CRANKSHAFT OIL CLEARANCE (See page [EM-179](#))

10. INSTALL WITH PIN PISTON SUB-ASSEMBLY

- (a) Coat the piston pin and pin holes in the piston with engine oil.
 (b) Align the cavity of the piston with the protruding portion on the connecting rod.

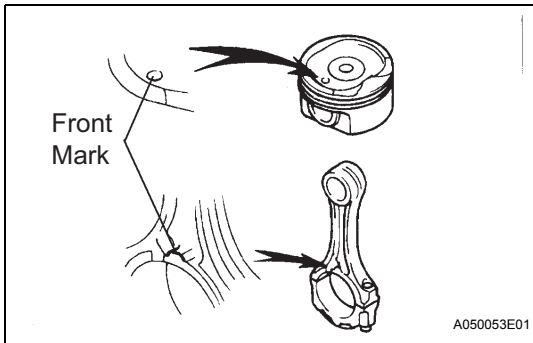

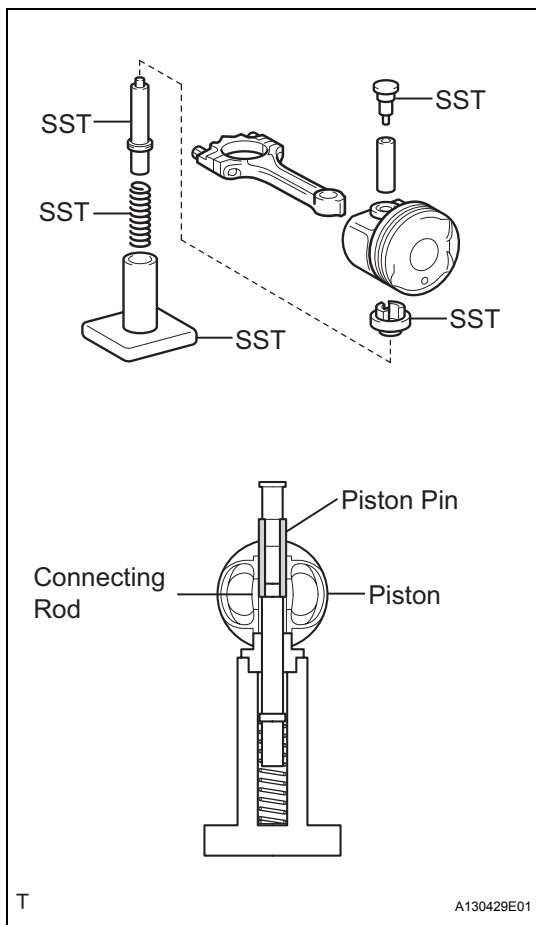

- (c) Using SST, press in the piston pin.
SST 09221-25026 (09221-00021, 09221-00030, 09221-00090, 09221-00150, 09221-00100)

NOTICE:

Keep the pistons, pins, rings, connecting rods and bearings in the correct order so that they can be returned to the original locations when reassembled.

EM

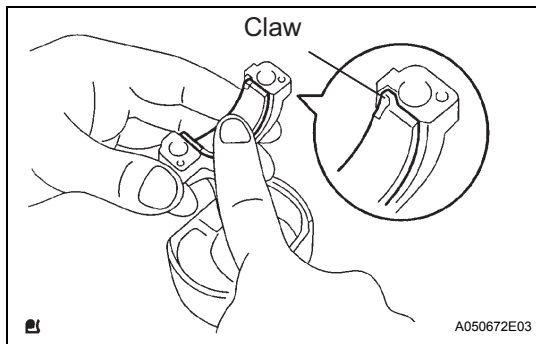

11. INSTALL CONNECTING ROD BEARING

- (a) Align the bearing claw with the groove of the connecting rod or connecting cap.

NOTICE:

Clean the back side of the bearing and the bearing surface of the connecting rod and keep them free of oil.

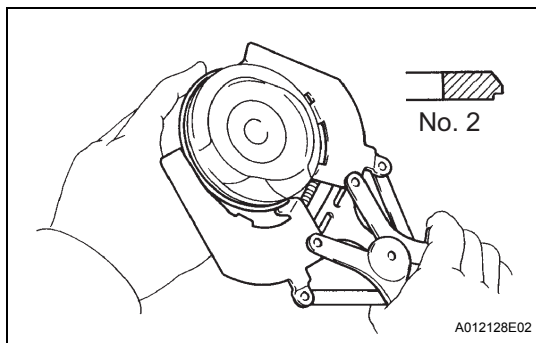

12. INSTALL PISTON RING SET

HINT:

When reusing the piston rings, install them onto the matched pistons with the surfaces facing correctly.

- (a) Install the oil ring expander and 2 side rails by hand.
 (b) Using a piston ring expander, install the 2 compression rings.

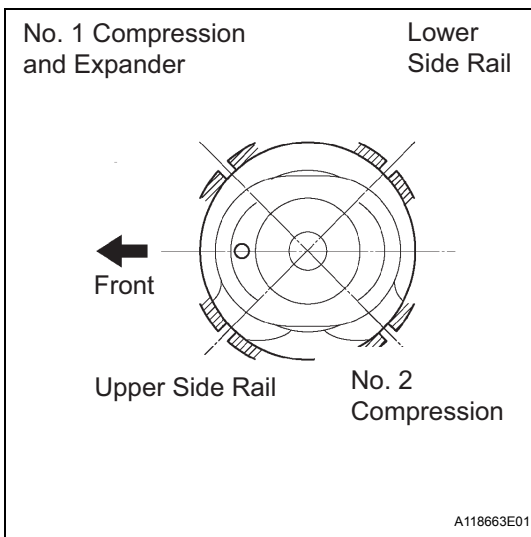

- (c) Position the piston rings so that the ring ends are as shown.

13. INSTALL PISTON SUB-ASSEMBLY WITH CONNECTING ROD

- (a) Apply engine oil to the cylinder walls, the pistons, and the surfaces of the connecting rod bearings.
- (b) Check the position of the piston ring ends.

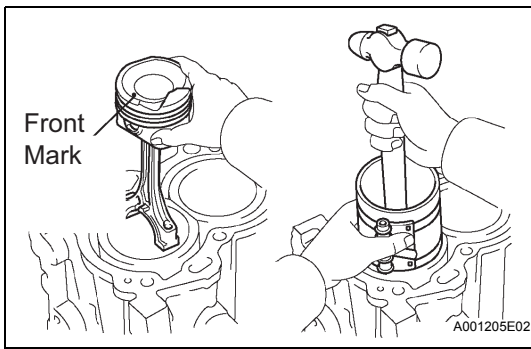

- (c) Using a piston ring compressor, push the correctly numbered piston and connecting rod assemblies into each cylinder with the front mark on the piston facing forward.

NOTICE:

- Clean the back side of the bearing and the bearing surface of the connecting rod cap and keep them free of oil.
- Match the numbered connecting rod cap with the connecting rod.

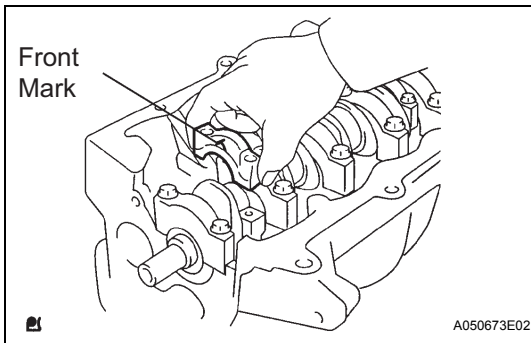

- (d) Make sure that the connecting rod and its cap are in the correct combination and that the front mark of the cap is facing in the correct mounting orientation, then install the cap onto the connecting rod.
- (e) Apply a light coat of engine oil to the threads of the connecting rod cap bolts.

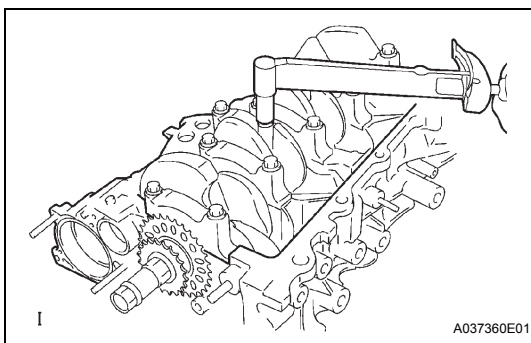

- (f) Using SST, tighten the bolts in several steps to the specified torque.

SST 09205-16010

Torque: 15 N*m (153 kgf*cm, 11 ft.*lbf)

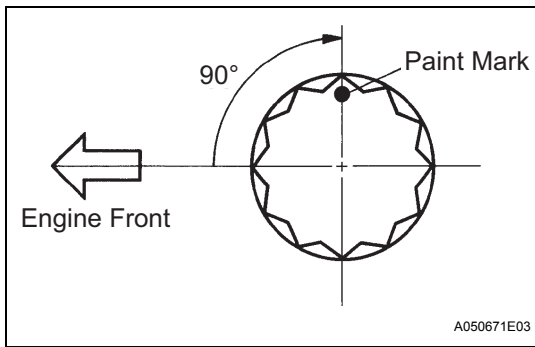

- (g) Mark the front of the connecting cap bolts with paint.
- (h) Retighten the cap bolts by 90° as shown.
- (i) Check that the crankshaft turns smoothly.

14. INSPECT CONNECTING ROD THRUST CLEARANCE (See page EM-173)

15. INSPECT CONNECTING ROD OIL CLEARANCE (See page EM-173)

16. INSTALL STUD BOLT

- (a) Using "Torx" socket wrench E5, install the 4 stud bolts.

Torque: 5.0 N*m (51 kgf*cm, 44 in.*lbf)

EM

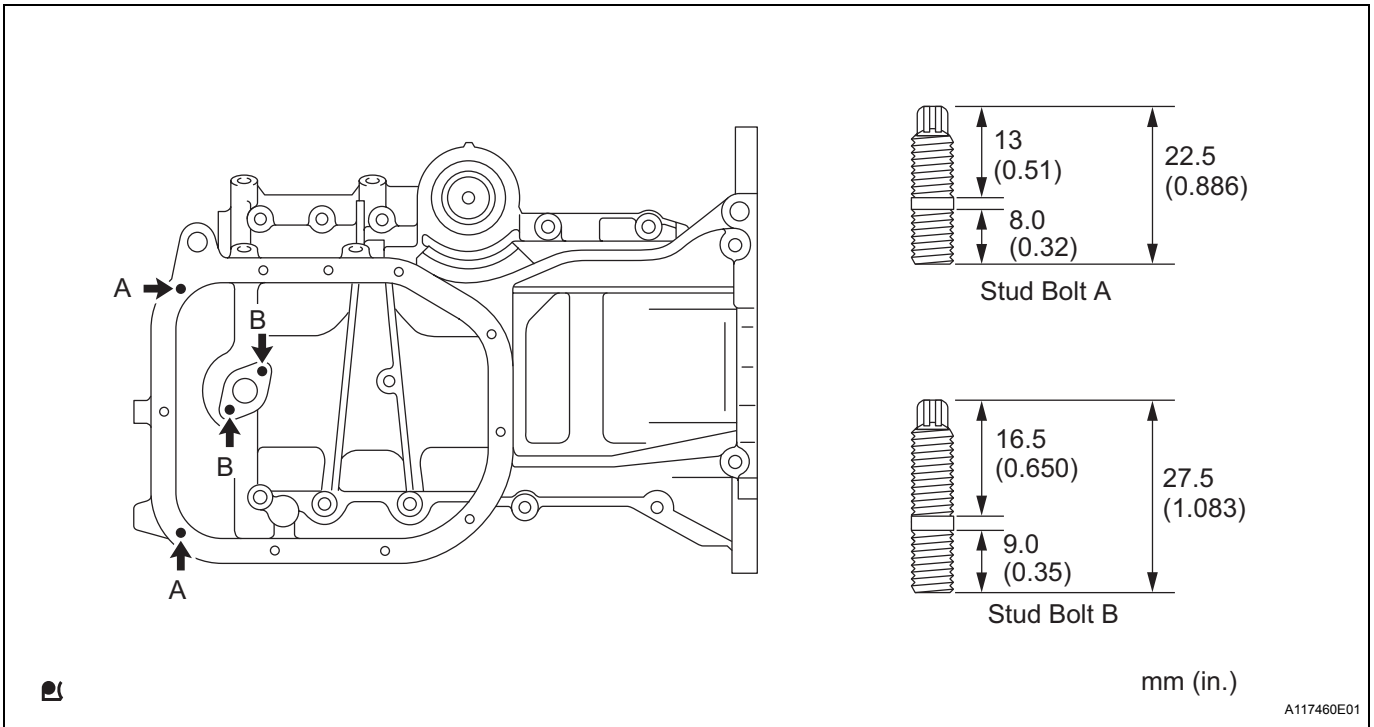

17. INSTALL OIL PAN SUB-ASSEMBLY

- (a) Remove any old packing material from the contact surface.
- (b) Apply a continuous bead of seal packing (Diameter 2.0 mm to 3.0 mm (0.079 to 0.118 in.)) to the oil pan mating surface as shown in the illustration.

Seal packing:

Toyota Genuine Seal Packing Black, Three Bond 1207B or Equivalent

NOTICE:

- Remove any oil from the contact surface.
- Install the oil pan within 3 minutes of applying the seal packing.
- Do not expose the seal to engine oil for at least within 2 hours after the installation.

- (c) Install 2 new O-rings onto the cylinder block.

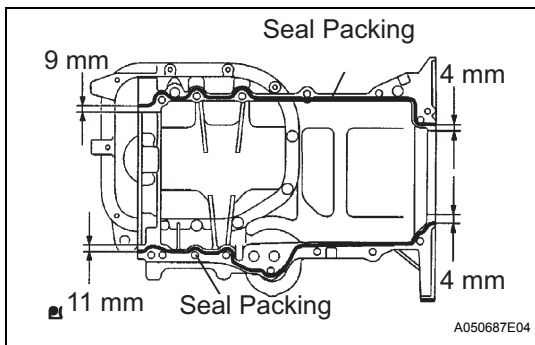

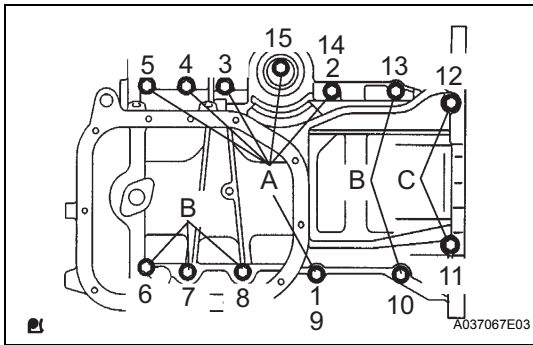

- (d) Using several steps, install and tighten the 13 bolts uniformly in the sequence shown in the illustration.

Torque: 24 N*m (245 kgf*cm, 18 ft.*lbf)

HINT:

Each bolt length is as follows:

Bolt A 49 mm (1.93 in.)

Bolt B 88 mm (3.47 in.)

Bolt C 144 mm (5.67 in.)

18. INSTALL OIL STRAINER SUB-ASSEMBLY

- (a) Install a new gasket and the oil strainer with the 2 nuts and the bolt.

Torque: 11 N*m (112 kgf*cm, 8.1 ft.*lbf)

19. INSTALL OIL PAN SUB-ASSEMBLY NO. 2

- (a) Remove any old packing material from the contact surface.

- (b) Apply a continuous bead of seal packing (Diameter 2.5 to 3.5 mm (0.0984 to 0.1378 in.)) to the oil pan mating surface as shown in the illustration.

Seal packing:

Toyota Genuine Seal Packing Black, Three Bond 1207B or Equivalent

NOTICE:

- Remove any oil from the contact surface.
- Install the oil pan within 3 minutes of applying the seal packing.
- Do not expose the seal to engine oil for at least 2 hours after the installation.
- Do not start the engine for at least 2 hours after the installation.

- (c) Install oil pan No. 2 with the 9 bolts and the 2 nuts.

Torque: 9.0 N*m (92 kgf*cm, 80 in.*lbf)

- (d) Install the drain plug with a new gasket.

Torque: 38 N*m (382 kgf*cm, 28 ft.*lbf)

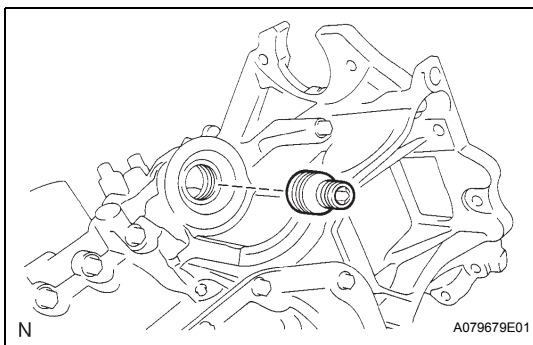
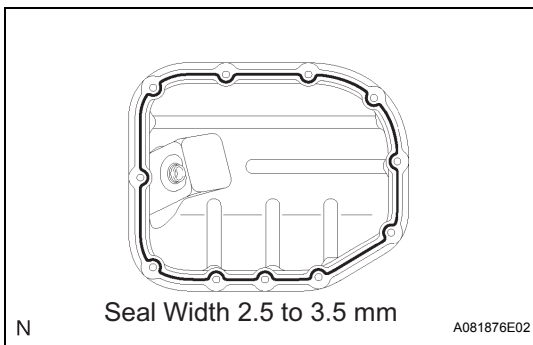

20. INSTALL OIL FILTER UNION

- (a) Using a 12 mm hexagon wrench, install the oil filter union.

Torque: 30 N*m (306 kgf*cm, 22 ft.*lbf)

21. INSTALL OIL FILTER SUB-ASSEMBLY

- (a) Check and clean the oil filter installation surface.

- (b) Apply clean engine oil to the gasket of a new oil filter.

- (c) Gently screw the oil filter into place, and tighten it until the gasket comes into contact with the seat.

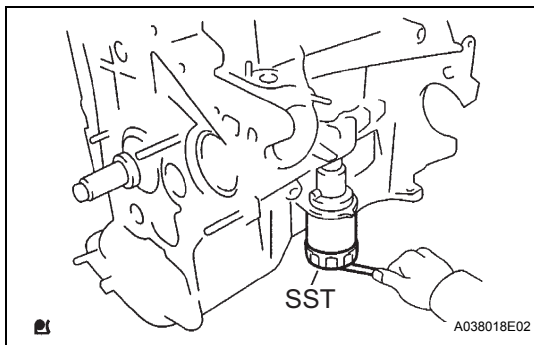

- (d) Using SST, tighten it an additional 3/4 turn.

SST 09228-06501

HINT:

When using a torque wrench, tighten it to the specified torque.

Torque: 13 N*m (133 kgf*cm, 9.5 ft.*lbf)

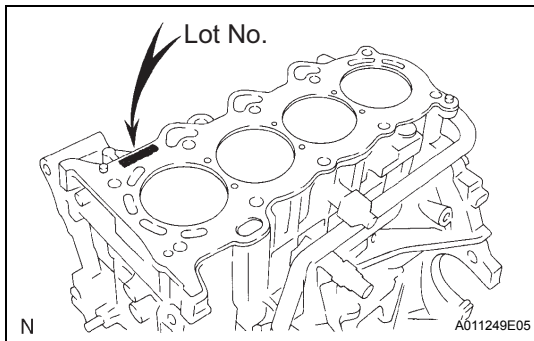

22. INSTALL CYLINDER HEAD GASKET

- (a) Place a new cylinder head gasket on the cylinder block with the Lot No. stamp facing upward.

NOTICE:

- Remove any oil from the contact surface.
- Pay attention to the mounting orientation of the cylinder head gasket.
- Place the cylinder head on the cylinder head gently in order not to damage the gasket.

23. INSTALL CYLINDER HEAD SUB-ASSEMBLY

HINT:

The cylinder head bolts are tightened in 2 successive steps.

- (a) Apply a light coat of engine oil to the threads of the cylinder head bolts.
- (b) Using several steps, install and tighten the 10 cylinder head bolts and plate washers uniformly with an 8 mm bi-hexagon wrench in the sequence shown in the illustration.

Torque: 29 N*m (300 kgf*cm, 22 ft.*lbf)

- (c) Mark the front of the cylinder head bolt with paint.

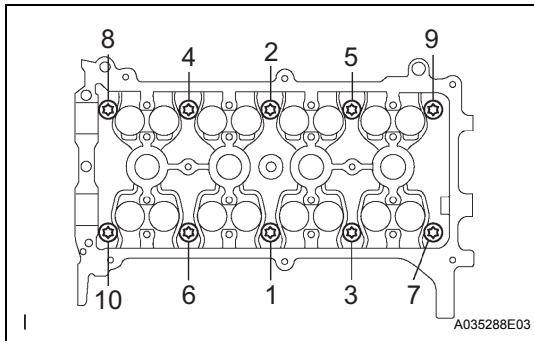

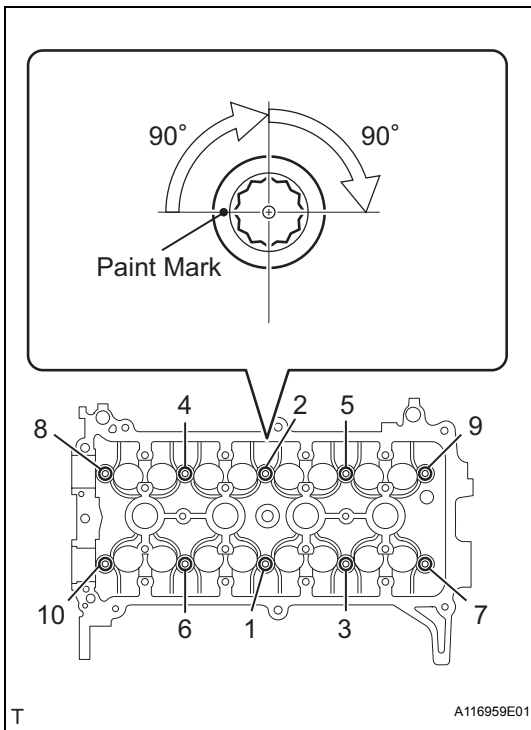

- (d) Retighten the cylinder head bolts by 90° and then an additional 90° as shown in the illustration.
- (e) Check that the paint mark is now at a 180° angle from the front.

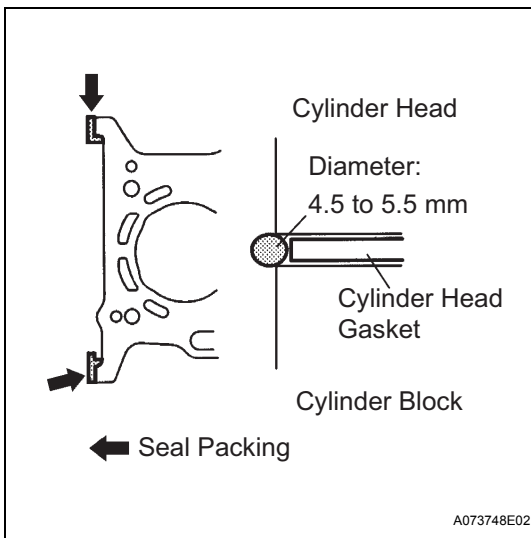

- (f) Apply a continuous bead of seal packing (Diameter 4.5 to 5.5 mm (0.177 to 0.217 in.)) as shown in the illustration.

Seal Packing:

Toyota Genuine Seal Packing Black, Three Bond 1207B or Equivalent

NOTICE:

- Remove any oil from the contact surface.
- Install the oil pump assembly within 3 minutes and tighten the bolts within 15 minutes of applying seal packing.

24. INSTALL ENGINE REAR OIL SEAL

- (a) Apply MP grease to a new oil seal lip.

NOTICE:

Keep the seal lip free of foreign matter.

- (b) Using SST and a hammer, tap in the oil seal until its surface is flush with the rear oil seal retainer edge.

SST 09223-56010

NOTICE:

- Do not tap the oil seal at an angle.
- Wipe any extra grease off the crankshaft.

25. INSTALL CAMSHAFT TIMING GEAR ASSEMBLY

NOTICE:

Install the camshaft timing gear assembly onto the camshaft with the lock pin of the camshaft timing gear assembly released.

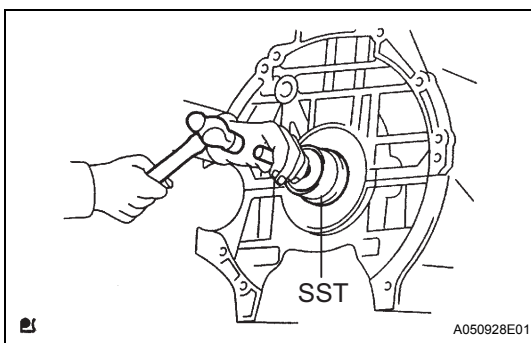

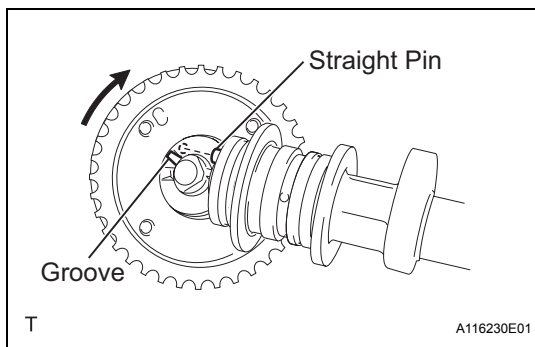

- (a) Put the camshaft timing gear assembly and camshaft together with the straight pin of the groove.
- (b) Turn the camshaft timing gear assembly clockwise while pushing it gently toward the camshaft. When the pin fits into the groove, push to ensure a good fit.

NOTICE:

Do not turn the camshaft timing gear in the retard direction (clockwise).

- (c) Check that there is no clearance between the gear fringe and the camshaft.
- (d) Tighten the flange bolt with the camshaft timing gear fixed.

Torque: 64 N*m (653 kgf*cm, 47 ft.*lbf)

NOTICE:

- Do not lock the camshaft timing gear assembly when tightening the bolt.
 - Release the lock pin of the camshaft timing gear assembly first, and tighten the bolt when the lock pin is locked in the most retarded position.
 - Tightening the bolts with the lock pin locked could cause breakage of the lock pin.
- (e) Check that the camshaft timing gear assembly moves smoothly in the retard direction (clockwise) and is locked in the most retarded position.

26. INSTALL CAMSHAFT

- (a) Apply a light coat of engine oil to the camshaft journals.
- (b) Place the camshaft on the cylinder head with the timing mark on the camshaft timing gear facing upward.
- (c) Examine the front marks and numbers and tighten the bolts in the sequence shown in the illustration.

Torque: 13 N*m (129 kgf*cm, 9.4 ft.*lbf)

NOTICE:

Tighten each bolt uniformly while keeping the camshaft level.

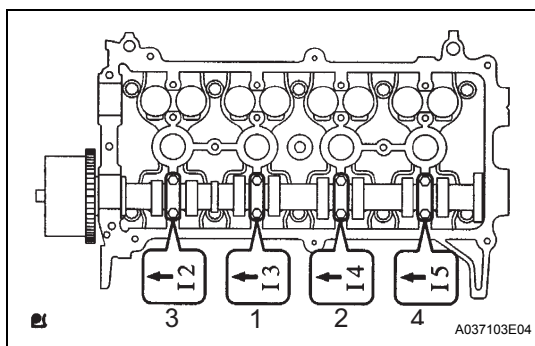

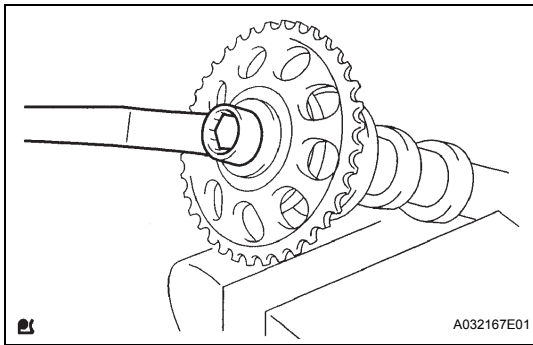
**27. INSTALL CAMSHAFT TIMING SPROCKET**

- (a) Clamp the camshaft in a vice.
- (b) Align the knock pin hole in the camshaft timing sprocket with the knock pin of the camshaft, and install the camshaft timing sprocket.

Torque: 64 N*m (653 kgf*cm, 47 ft.*lbf)

NOTICE:

Do not damage the camshaft.

28. INSTALL NO. 2 CAMSHAFT

- (a) Apply a light coat of engine oil to the camshaft journals.
- (b) Place the camshaft on the cylinder head with the timing mark on the camshaft timing gear facing upward.
- (c) Examine the front marks and numbers on camshaft bearing caps No. 1 and No. 2 and check that the sequence is as shown in the illustration. Then uniformly tighten the bolts, in several steps, in the sequence shown in the illustration.

Torque: 13 N*m (129 kgf*cm, 9.4 ft.*lbf) for bearing cap No. 2
23 N*m (235 kgf*cm, 17 ft.*lbf) for bearing cap No. 1

NOTICE:

Tighten each bolt uniformly while keeping the camshaft level.

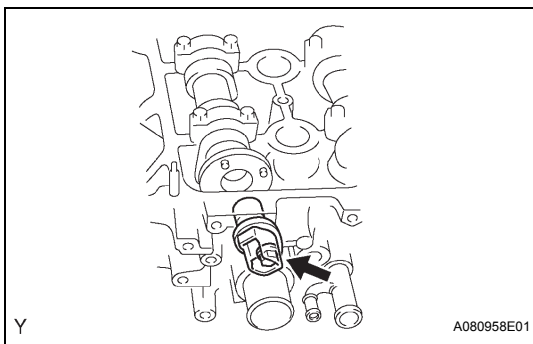
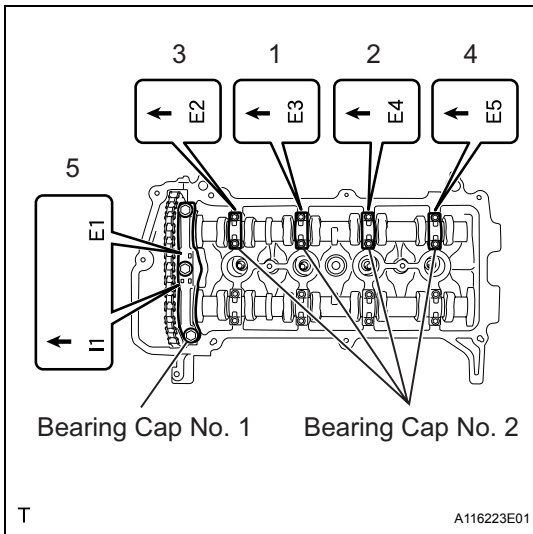
**29. INSTALL CAMSHAFT POSITION SENSOR**

- (a) Apply engine oil to the O-ring.

NOTICE:

If the O-ring is damaged, replace the camshaft position sensor.

- (b) Install the camshaft position sensor with the bolt.

Torque: 8.0 N*m (82 kgf*cm, 71 in.*lbf)

TDC:

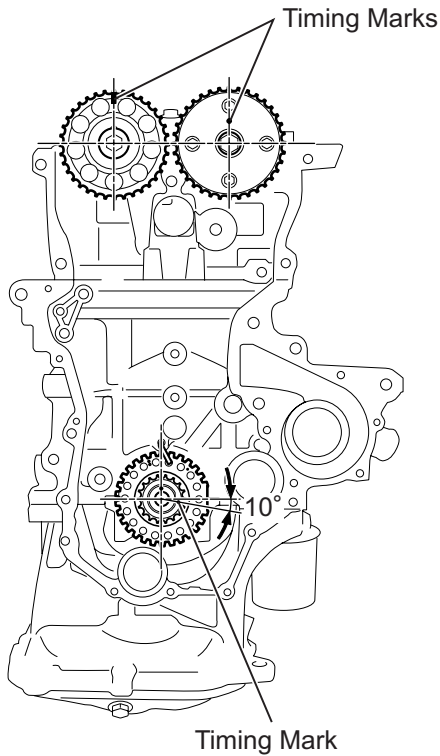

T

A116571E01

30. INSTALL CHAIN SUB-ASSEMBLY

- (a) Make sure that all the timing marks are in the positions (TDC) shown in the illustration.

HINT:

The positions of the timing marks may differ from the predetermined positions due to the force of the valve spring.

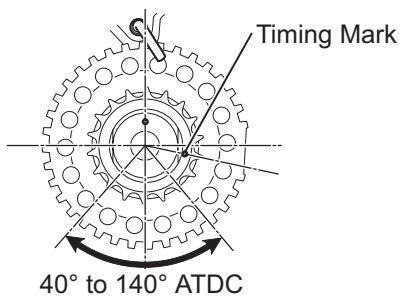

T

A116573E01

- (b) Set the timing mark of the crankshaft in a position between 40 and 140°ATDC, as illustrated.

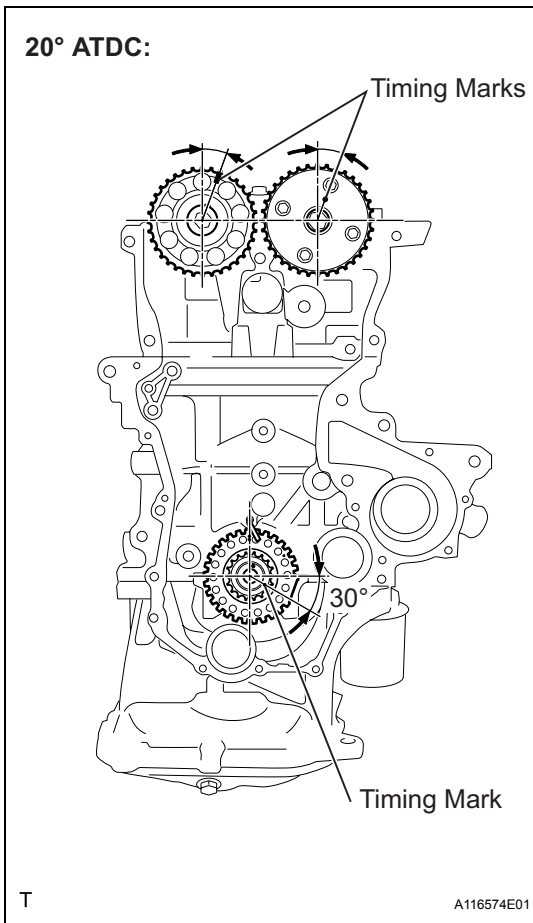

- (c) Set the camshaft timing gear and the camshaft timing sprocket in the positions (20°ATDC) shown in the illustration.
- (d) Set the crankshaft in the position (20°ATDC) shown in the illustration.

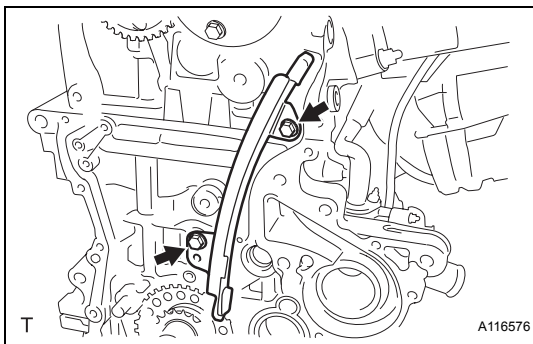

- (e) Install chain vibration damper No. 1 with the 2 bolts.
Torque: 9.0 N*m (92 kgf*cm, 80 in.*lbf)

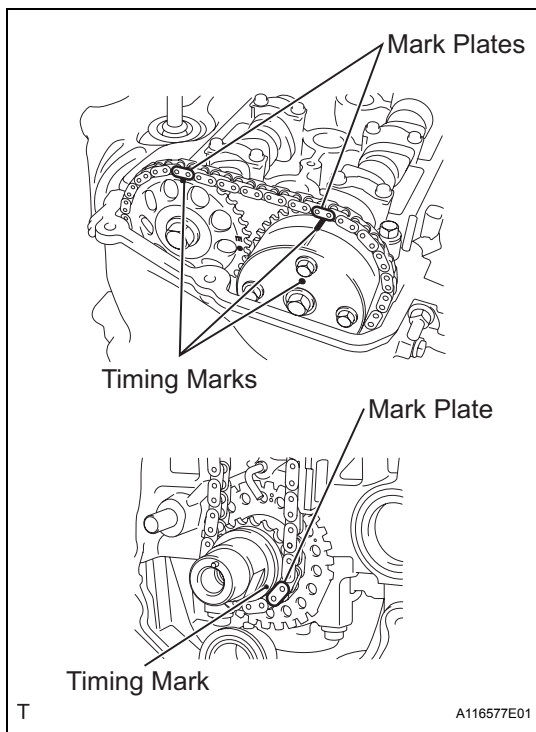

- (f) Align the timing marks of the camshaft with the mark plates of the timing chain and install the timing chain.

HINT:

Align the timing marks with the mark plates while turning the hexagonal service portion of the camshaft using a wrench.

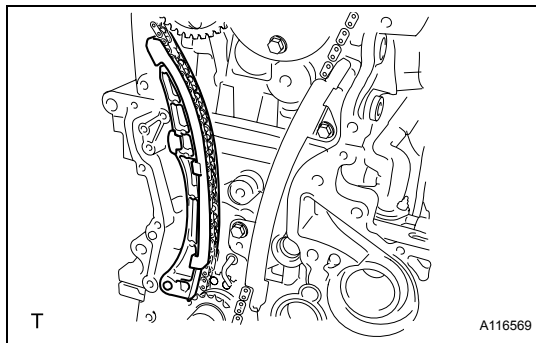

31. INSTALL CHAIN TENSIONER SLIPPER

- (a) Install the chain tensioner slipper.

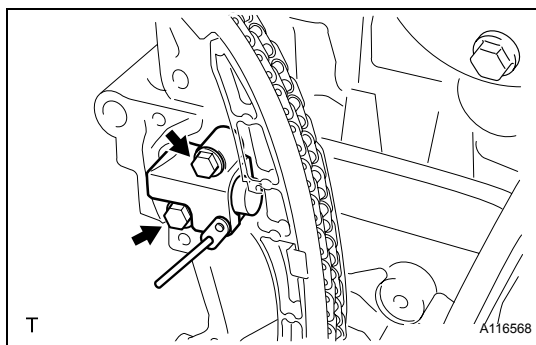

32. INSTALL CHAIN TENSIONER ASSEMBLY NO. 1

- (a) Install chain tensioner assembly No. 1 with the 2 bolts.

Torque: 9.0 N*m (92 kgf*cm, 80 in.*lbf)

- (b) Remove the bar from chain tensioner assembly No. 1.

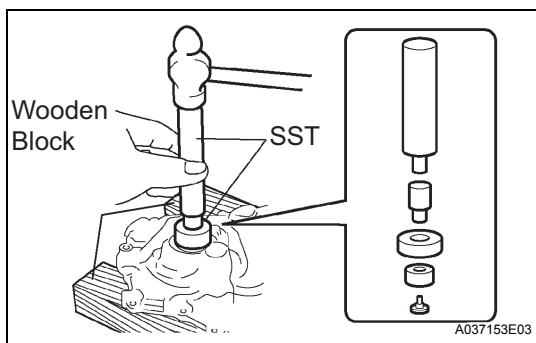

33. INSTALL OIL PUMP SEAL

- (a) Using SST and a hammer, tap in a new oil seal until its surface is flush with the timing chain cover edge.

SST 09950-60010 (09951-00250, 09951-00380, 09952-06010), 09950-70010 (09951-07100)

NOTICE:

- Do not tap the oil seal at an angle.
- Keep the seal lip free of foreign matter.

- (b) Apply MP grease to the oil seal lip.

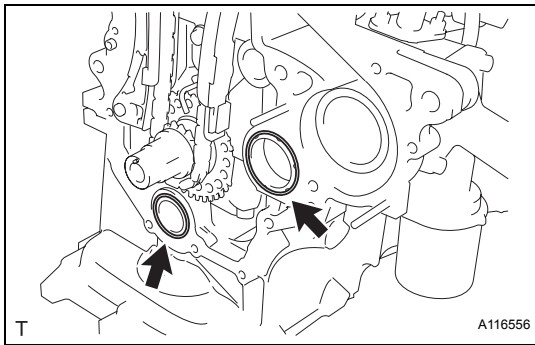
**34. INSTALL OIL PUMP ASSEMBLY**

- (a) Install 2 new O-rings in the 2 locations shown in the illustration.

(b) Apply seal packing to the oil pump assembly, cylinder head and cylinder block as shown in the illustration.

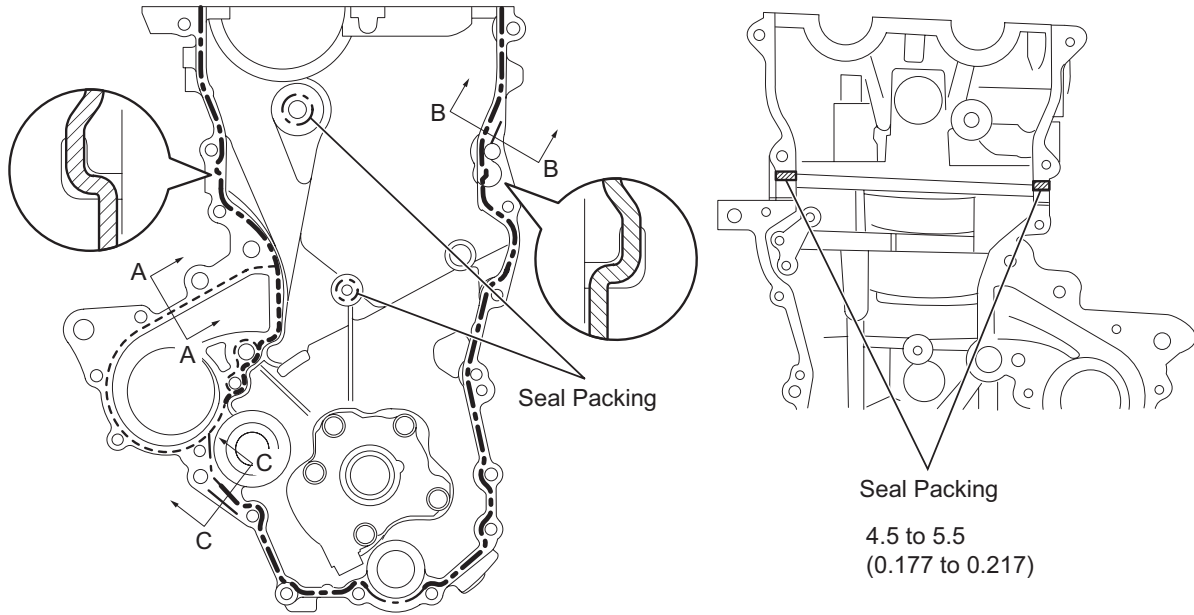

A-A
1.5 to 2.0
(0.059 to 0.079)

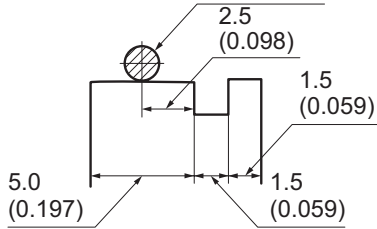

B-B, C-C

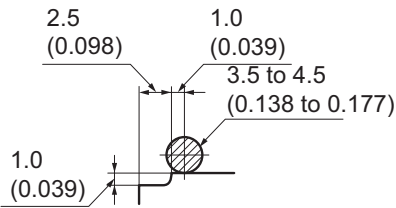
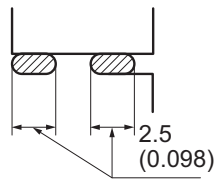

Seal Width (Other Part)

----- 3.5 to 4.5
(0.138 to 0.177)

----- 1.5 to 2.0
(0.059 to 0.079)

Seal Width (Water Pump Part)

----- 3.5 to 4.5
(0.138 to 0.177)

----- 1.5 to 2.0
(0.059 to 0.079)

mm (in.)

Seal packing:

Water pump part Toyota Genuine Seal Packing 1282B, Three Bond 1282B or Equivalent
Other part Toyota Genuine Seal Packing Black, Three Bond 1207B or Equivalent

NOTICE:

- Remove any oil from the contact surface.
- Install the oil pump assembly within 3 minutes and tighten the bolts and nut within 15 minutes of applying the the seal packing.
- Do not expose the seal to engine oil for at least 2 hours after the installation.

- (c) Align the keyway of the oil pump rotor with the rectangular portion of the crankshaft, and slide the oil pump into place.

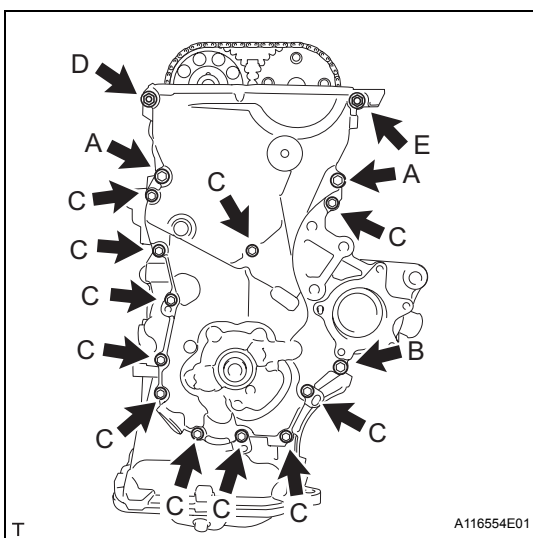
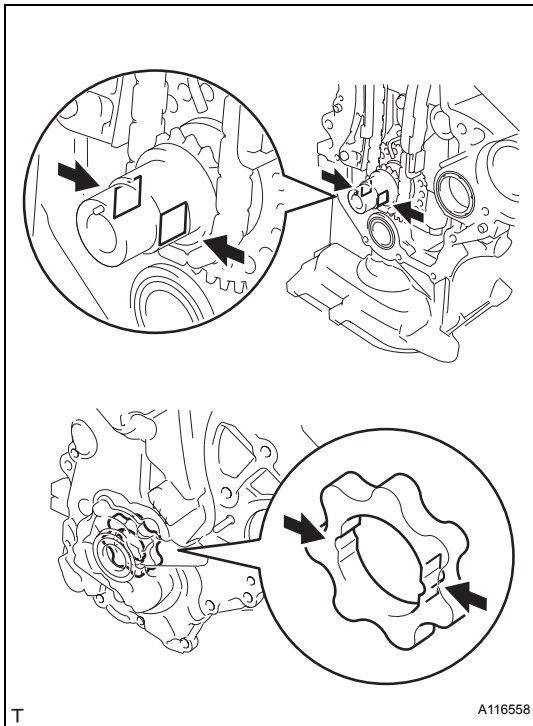

- (d) Install the oil pump assembly with the 15 bolts and nut. Tighten the bolts and nut uniformly in several steps.

Torque: 32 N*m (326 kgf*cm, 24 ft.*lbf) for bolt A
11 N*m (112 kgf*cm, 8.1 ft.*lbf) for bolt B
11 N*m (112 kgf*cm, 8.1 ft.*lbf) for bolt C
24 N*m (245 kgf*cm, 18 ft.*lbf) for nut D
24 N*m (245 kgf*cm, 18 ft.*lbf) for bolt E

NOTICE:

Install the mounting bracket and water pump within 15 minutes of installing the oil pump assembly.

HINT:

Each bolt length is as follows.

A: 30 mm (1.181 in.)

B: 35 mm (1.378 in.)

C: 20 mm (0.787 in.)

E: 20 to 14 mm (0.787 to 0.551 in.) Double ended bolt

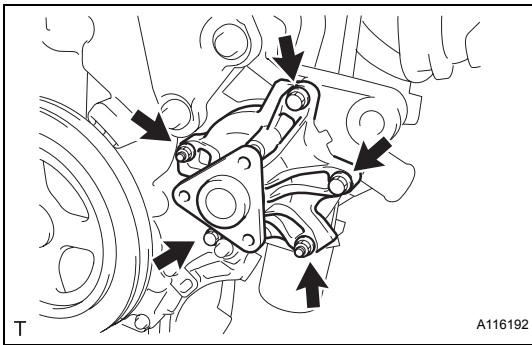
**35. INSTALL WATER PUMP ASSEMBLY**

- (a) Install the water pump and a new gasket with the 3 bolts and 2 nuts.

Torque: 11 N*m (112 kgf*cm, 8.1 ft.*lbf)

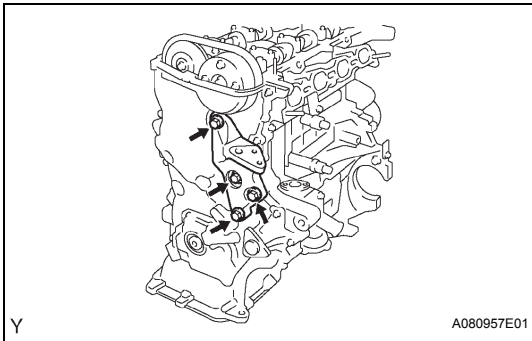
**36. INSTALL TRANSVERSE ENGINE ENGINE MOUNTING BRACKET**

- (a) Install the transverse engine mounting bracket with the 4 bolts.

Torque: 55 N*m (561 kgf*cm, 41 ft.*lbf)

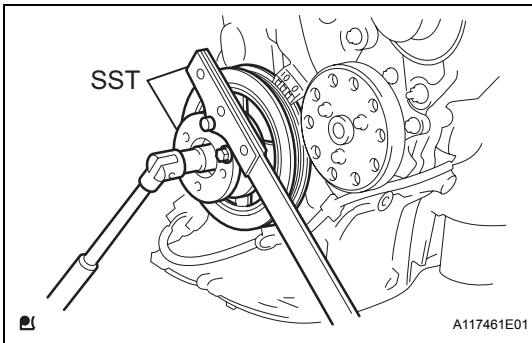
**37. INSTALL CRANKSHAFT DAMPER SUB-ASSEMBLY**

- (a) Align the pin hole in the crankshaft damper with the pin position and install the crankshaft damper sub-assembly.

- (b) Provisionally install the bolt.

- (c) Using 2 SSTs, tighten the bolt while holding the crankshaft damper sub-assembly.

SST 09213-14010 (91651-60865), 09330-00021

Torque: 128 N*m (1305 kgf*cm, 95 ft.*lbf)

NOTICE:

Check the SST installation positions when installing them, to avoid the SST fixing bolts from coming into contact with the oil pump assembly.

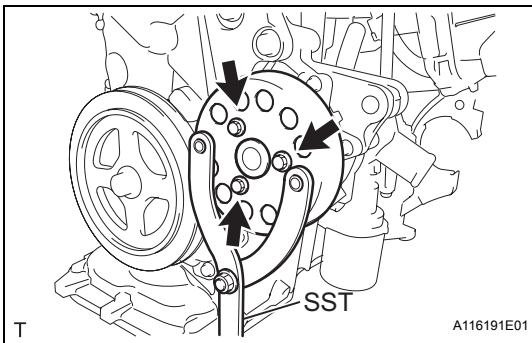
**38. INSTALL WATER PUMP PULLEY**

- (a) Using SST, install the pump pulley with the 3 bolts.

SST 09960-10010 (09962-01000, 09963-00700)

Torque: 15 N*m (153 kgf*cm, 11 ft.*lbf)

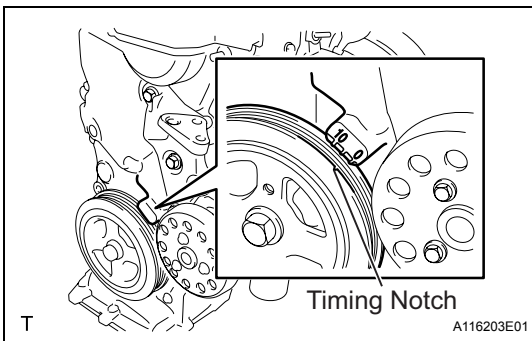
**39. INSPECT VALVE CLEARANCE**

- (a) Set the No. 1 cylinder to TDC/compression.

- (1) Turn the crankshaft damper, and align its timing notch with the timing mark "0" of the oil pump.

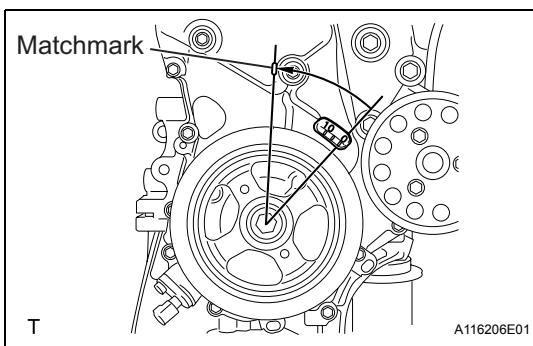
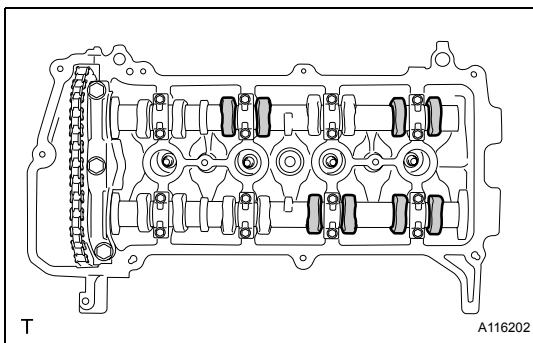
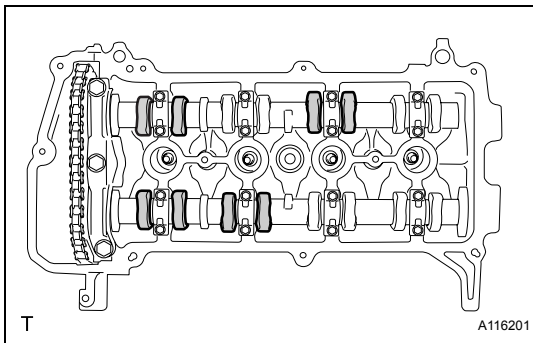
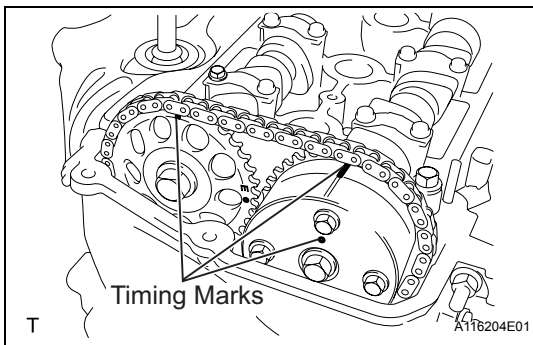

- (2) Check that the timing marks on the camshaft timing sprocket and camshaft timing gear are all facing upward, as shown in the illustration.
HINT:
If not, turn the crankshaft 1 complete revolution (360°) and align the marks as above.

- (b) Check the valves indicated in the illustration.
- (1) Using a feeler gauge, measure the clearance between the valve lifter and camshaft.
Valve clearance (cold):
for intake:
0.15 to 0.25 mm (0.006 to 0.010 in.)
for exhaust:
0.25 to 0.35 mm (0.010 to 0.014 in.)
- (2) Record any out-of-specification valve clearance measurements. They will be used later to determine the required replacement adjusting shim.
- (c) Turn the crankshaft 1 complete revolution (360°) and align its timing notch with timing mark "0" of the oil pump.
- (d) Check the valves indicated in the illustration.
- (1) Using a feeler gauge, measure the clearance between the valve lifter and camshaft.
Valve clearance (cold):
for Intake:
0.15 to 0.25 mm (0.006 to 0.010 in.)
for Exhaust:
0.25 to 0.35 mm (0.010 to 0.014 in.)
- (2) Record any out-of-specification valve clearance measurements. They will be used later to determine the required replacement adjusting shim.

40. ADJUST VALVE CLEARANCE

NOTICE:

When rotating the camshaft with the timing chain removed, rotate the crankshaft damper counterclockwise 40° from the TDC and align its timing notch with the matchmark of the timing chain cover to prevent the pistons from coming into contact with the valves.

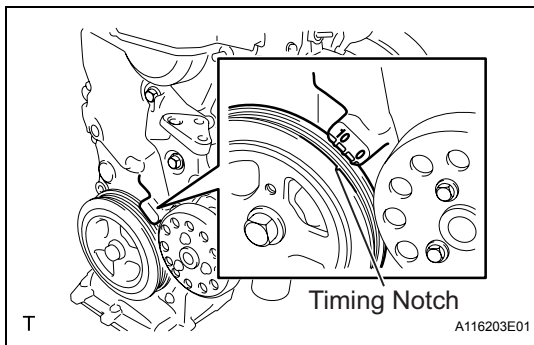

- (a) Set the No. 1 cylinder to TDC/compression.
 (1) Turn the crankshaft damper, and align its timing notch with timing mark "0" of the oil pump.

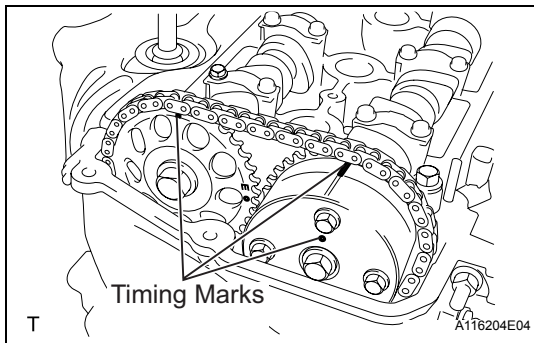

- (2) Check that the timing marks on the camshaft timing sprocket and camshaft timing gear are all facing upward as shown in the illustration.
 HINT:
 If not, turn the crankshaft 1 complete revolution (360°) and align the marks as above.

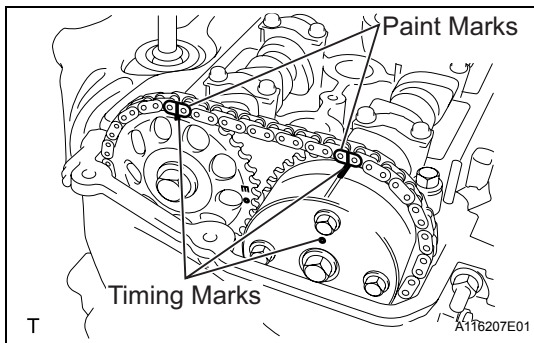

- (b) Put paint marks on the chain in the places where the timing marks of the camshaft timing sprocket and the camshaft timing gear are located.

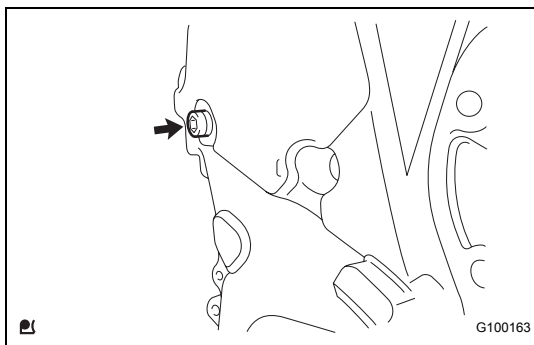

- (c) Using an 8 mm hexagon wrench, remove the screw plug.

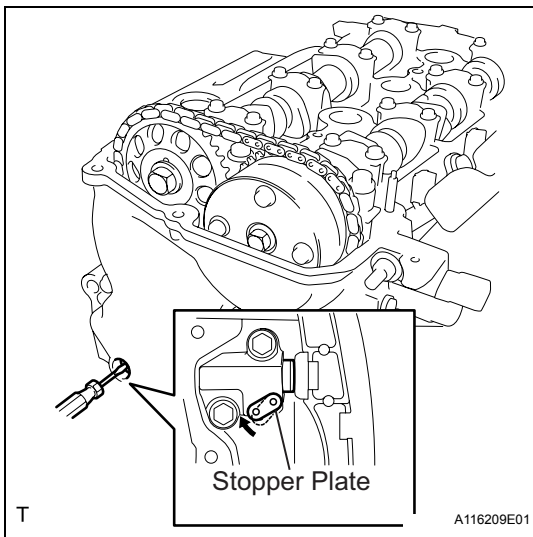

- (d) Insert a screwdriver into the service hole in the chain tensioner to pull the stopper plate of the chain tensioner upward.

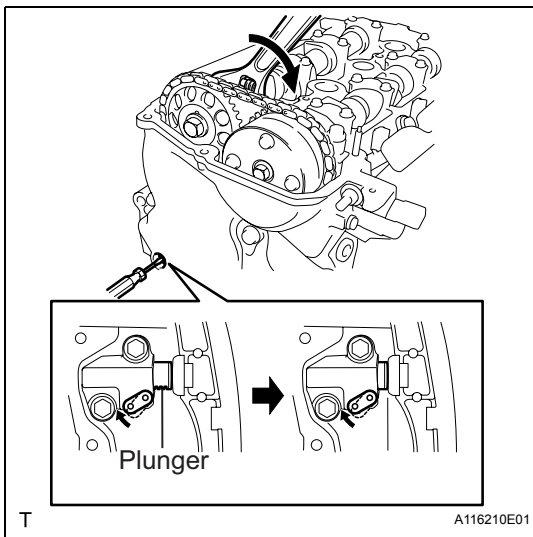

- (e) Using a wrench, rotate the No. 2 camshaft clockwise to push in the plunger of the chain tensioner.

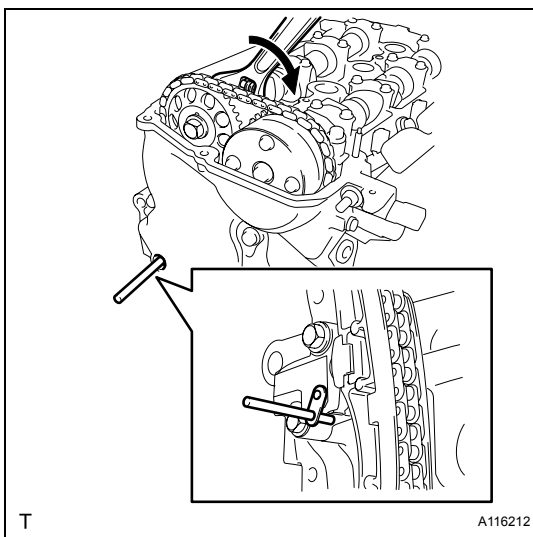

- (f) Remove the screwdriver from the service hole, then align the hole in the stopper plate with the service hole and insert a 3 mm (0.12 in.) diameter bar into the holes to hold the stopper plate.

HINT:

- Fix the stopper plate using the bar while rotating the camshaft right and left slightly.
- Hold the bar with tape so that it does not come out.

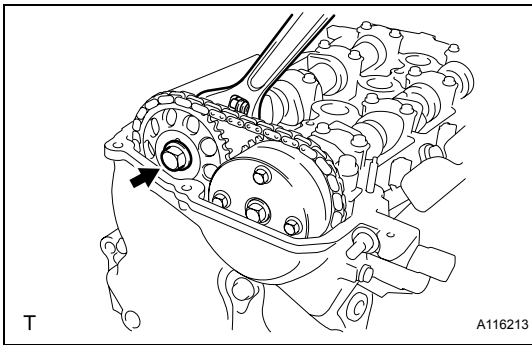

- (g) Using a wrench, hold the hexagonal lobe of No. 2 camshaft and remove the flange bolt.

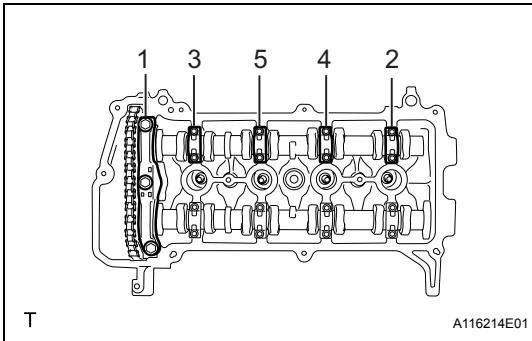

- (h) Using several steps, loosen and remove the 11 bearing cap bolts uniformly in the sequence shown in the illustration, then remove camshaft bearing cap No. 1 and camshaft bearing cap No. 2.

NOTICE:

Loosen each bolt uniformly while keeping the camshaft level.

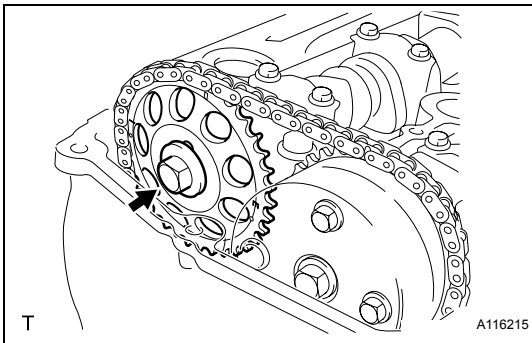

- (i) Remove the flange bolt and remove the camshaft timing sprocket.

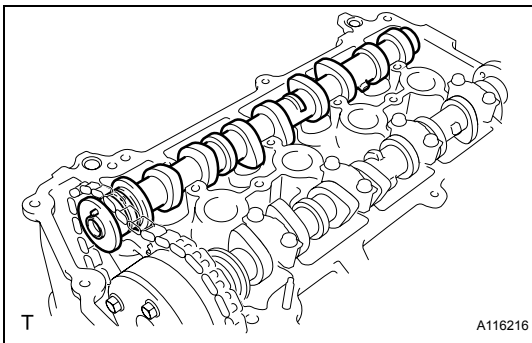

- (j) Remove the No. 2 camshaft.

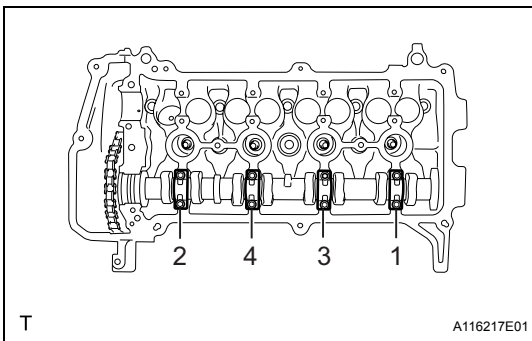

- (k) Using several steps, loosen and remove the 8 bearing cap bolts uniformly in the sequence shown in the illustration, then remove camshaft bearing cap No. 2.

NOTICE:

Loosen the bolts uniformly while keeping the camshaft level.

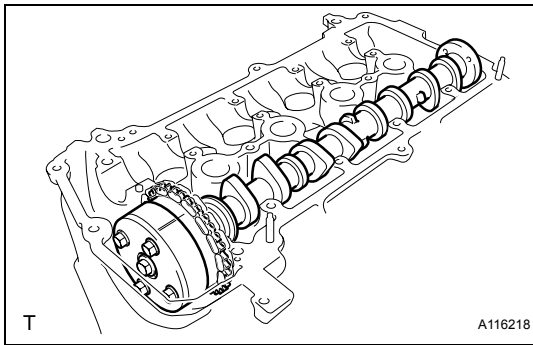

- (l) Hold the chain by hand, and remove the camshaft and the camshaft timing gear assembly.

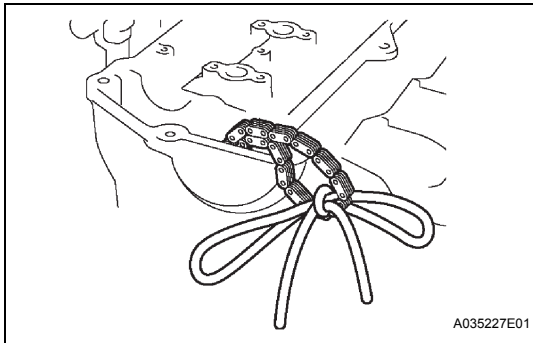

- (m) Tie the chain with a piece of string as shown in the illustration.

- (n) Remove the valve lifters.

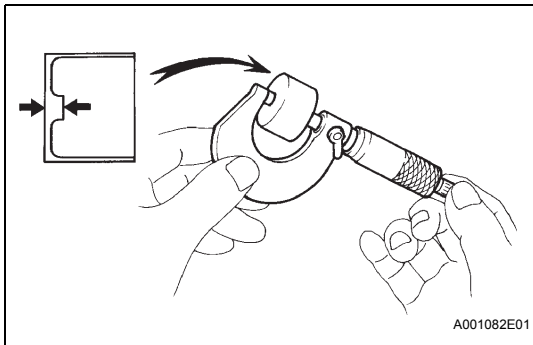

- (o) Using a micrometer, measure the thickness of the removed lifter.
- (p) Calculate the thickness of the new lifter so that the valve clearance comes to within the specified values.

A	Thickness of new lifter
B	Thickness of used lifter
C	Measured valve clearance

Valve clearance:

Intake $A = B + (C - 0.20 \text{ mm (0.008 in.)})$

Exhaust $A = B + (C - 0.30 \text{ mm (0.012 in.)})$

- (q) Select a new lifter with a thickness as close to the calculated values as possible.

HINT:

Lifters are available in 35 sizes in increments of 0.020 mm (0.0008 in.), from 5.060 mm (0.1992 in.) to 5.740 mm (0.2260 in.).

Intake valve clearance (cold):
0.15 to 0.25 mm (0.006 to 0.010 in.)

EXAMPLE:

A 5.250 mm (0.2067 in.) lifter is installed, and the measured clearance is 0.400 mm (0.0158 in.). Replace the 5.250 mm (0.2067 in.) lifter with a new No. 46 lifter.

New Shim Thickness

Shim No.	Thickness	Shim No.	Thickness	Shim No.	Thickness
06	5.060 (0.1992)	30	5.300 (0.2087)	54	5.540 (0.2181)
08	5.080 (0.2000)	32	5.320 (0.2094)	56	5.560 (0.2189)
10	5.100 (0.2008)	34	5.340 (0.2102)	58	5.580 (0.2197)
12	5.120 (0.2016)	36	5.360 (0.2110)	60	5.600 (0.2205)
14	5.140 (0.2024)	38	5.380 (0.2118)	62	5.620 (0.2213)
16	5.160 (0.2031)	40	5.400 (0.2126)	64	5.640 (0.2220)
18	5.180 (0.2039)	42	5.420 (0.2134)	66	5.660 (0.2228)
20	5.200 (0.2047)	44	5.440 (0.2142)	68	5.680 (0.2236)
22	5.220 (0.2055)	46	5.460 (0.2150)	70	5.700 (0.2244)
24	5.240 (0.2063)	48	5.480 (0.2157)	72	5.720 (0.2252)
26	5.260 (0.2071)	50	5.500 (0.2165)	74	5.740 (0.2260)
28	5.280 (0.2079)	52	5.520 (0.2173)		

EM

Exhaust valve clearance (cold):
0.25 to 0.35 mm (0.010 to 0.014 in.)

EXAMPLE:

A 5.340 mm (0.2102 in.) lifter is installed, and the measured clearance is 0.440 mm (0.0173 in.). Replace the 5.340 mm (0.2102 in.) lifter with a new No. 48 lifter.

New Shim Thickness

Shim No.	Thickness	Shim No.	Thickness	Shim No.	Thickness
06	5.060 (0.1992)	30	5.300 (0.2087)	54	5.540 (0.2181)
08	5.080 (0.2000)	32	5.320 (0.2094)	56	5.560 (0.2189)
10	5.100 (0.2008)	34	5.340 (0.2102)	58	5.580 (0.2197)
12	5.120 (0.2016)	36	5.360 (0.2110)	60	5.600 (0.2205)
14	5.140 (0.2024)	38	5.380 (0.2118)	62	5.620 (0.2213)
16	5.160 (0.2031)	40	5.400 (0.2126)	64	5.640 (0.2220)
18	5.180 (0.2039)	42	5.420 (0.2134)	66	5.660 (0.2228)
20	5.200 (0.2047)	44	5.440 (0.2142)	68	5.680 (0.2236)
22	5.220 (0.2055)	46	5.460 (0.2150)	70	5.700 (0.2244)
24	5.240 (0.2063)	48	5.480 (0.2157)	72	5.720 (0.2252)
26	5.260 (0.2071)	50	5.500 (0.2165)	74	5.740 (0.2260)
28	5.280 (0.2079)	52	5.520 (0.2173)		

EM

- (r) Install the selected valve lifter.
- (s) Apply a light coat of engine oil to the camshaft and camshaft journals.
- (t) Install the chain onto the camshaft timing gear with the paint mark and the timing mark aligned, as shown in the illustration.

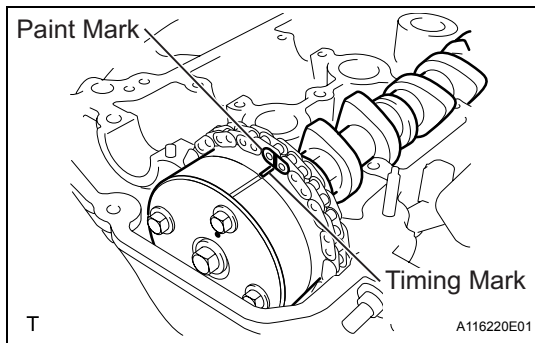

- (u) Examine the front marks and the numbers on camshaft bearing cap No. 2 and check that the sequence is as shown in the illustration. Then uniformly tighten the bolts in several steps in the sequence shown in the illustration.

Torque: 13 N*m (129 kgf*cm, 9.4 ft.*lbf)

NOTICE:

Tighten the bolts uniformly while keeping the camshaft level.

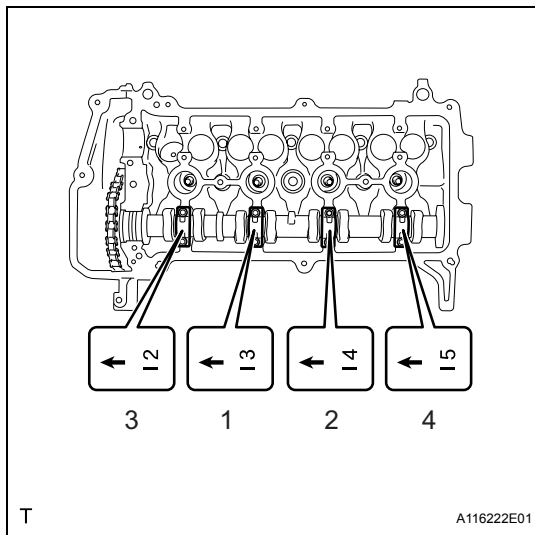

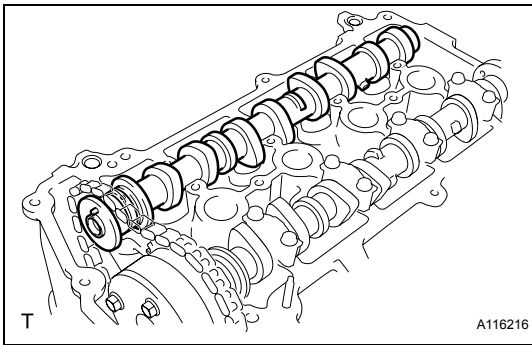

(v) Install camshaft No. 2.

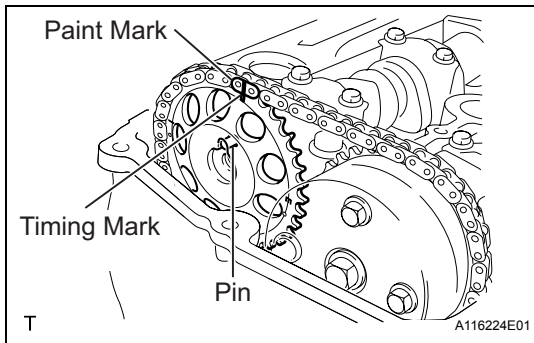

- (w) Hold the chain, and align the timing mark on the camshaft timing sprocket with the paint mark of the chain.
- (x) Align the alignment pin hole in the camshaft timing sprocket with the alignment pin of the camshaft, and install the sprocket onto the camshaft.

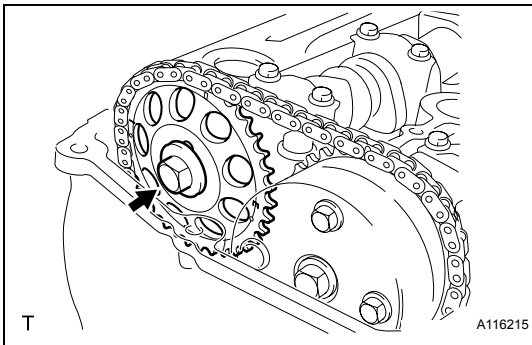

(y) Provisionally install the flange bolt.

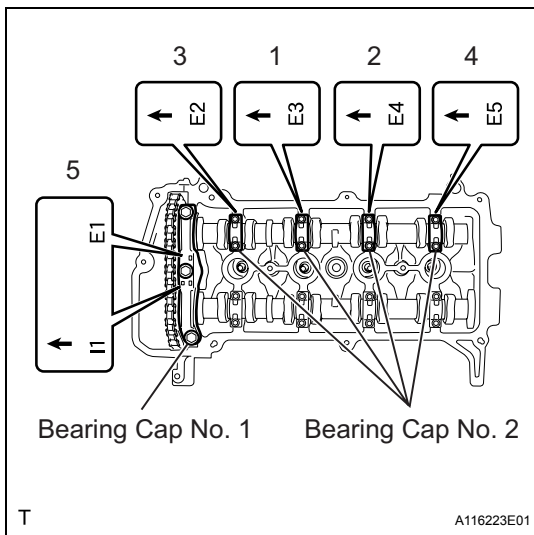

(z) Examine the front marks and the numbers of camshaft bearing cap No. 1 and camshaft bearing cap No. 2 and check that the sequence is as shown in the illustration. Then uniformly tighten the bolts, in several steps, in the sequence shown in the illustration.

Torque: 13 N*m (129 kgf*cm, 9.4 ft.*lbf) for bearing cap No. 2
23 N*m (235 kgf*cm, 17 ft.*lbf) for bearing cap No. 1

NOTICE:
Tighten the bolts uniformly while keeping the camshaft level.

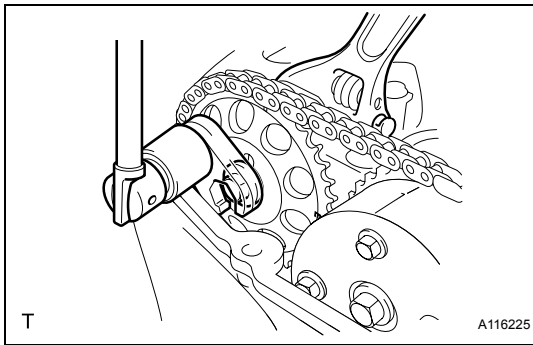

- (aa) Using a wrench, hold the hexagonal lobe of camshaft No. 2, and install the flange bolt.

Torque: 64 N*m (653 kgf*cm, 47 ft.*lbf)
SST 09023-38400

- (ab) Remove the bar from the timing chain tensioner.

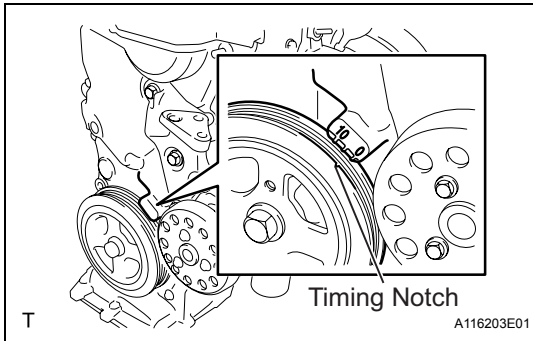

- (ac) Turn the crankshaft damper, and align its timing notch with the timing mark "0" of the oil pump.

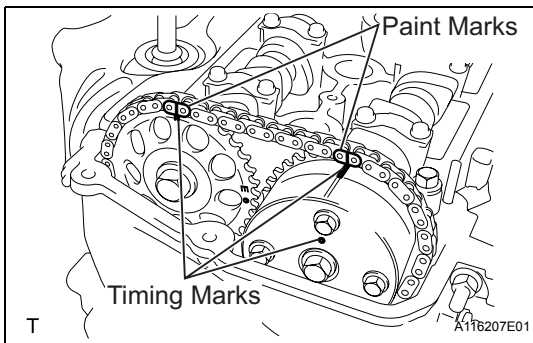

- (ad) Check that all the pairs of timing marks are aligned.

- (ae) Apply adhesive to the end 2 or 3 threads of the screw plug.

Adhesive:

Toyota Genuine Adhesive 1324, Three Bond 1324 or Equivalent

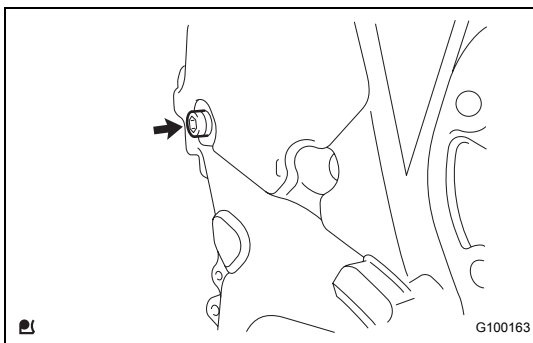

- (af) Using an 8 mm hexagon wrench, install the screw plug.

Torque: 15 N*m (153 kgf*cm, 11 ft.*lbf)

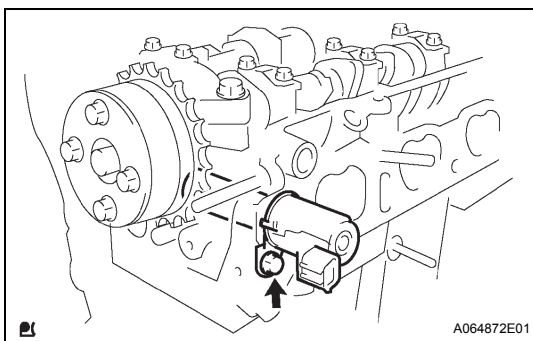

41. INSTALL CAMSHAFT TIMING OIL CONTROL VALVE ASSEMBLY

- (a) Apply a light coat of engine oil to a new O-ring, and install it onto the camshaft timing oil control valve.

- (b) Install the camshaft timing oil control valve with the bolt.

Torque: 7.5 N*m (76 kgf*cm, 66 in.*lbf)

NOTICE:

Do not twist the O-ring.

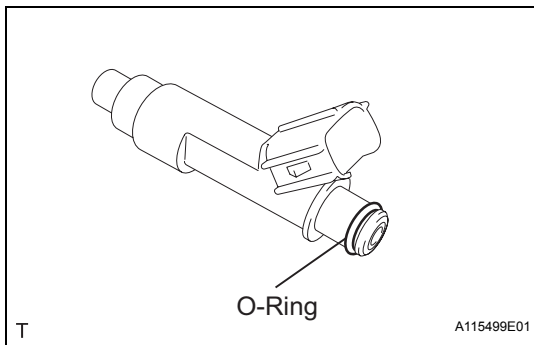
**42. INSTALL FUEL INJECTOR ASSEMBLY**

- (a) Apply a light coat of gasoline or spindle oil to new O-rings, then install one onto each fuel injector.
- (b) Apply a light coat of gasoline or spindle oil to the contact surfaces of the fuel delivery pipe and the O-ring of the fuel injector.

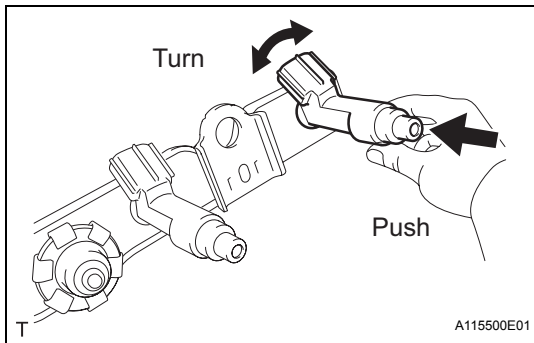

- (c) While turning the fuel injector left and right, install it onto the fuel delivery pipe.

NOTICE:

- Do not twist the O-ring.
- After installing the fuel injectors, check that they turn smoothly. If not, replace the O-ring with a new one.

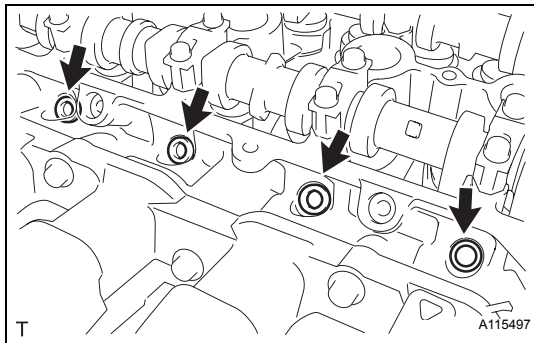
**43. INSTALL INJECTOR VIBRATION INSULATOR**

- (a) Install 4 new injector vibration insulators onto the cylinder head.

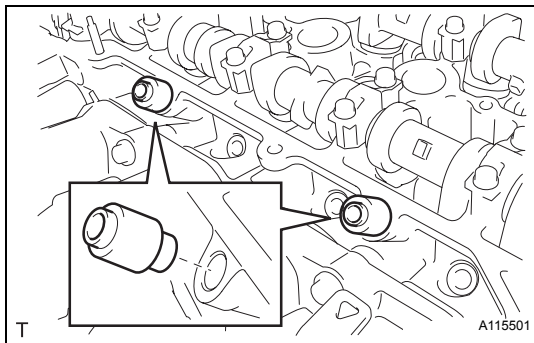
**44. INSTALL DELIVERY PIPE NO. 1 SPACER**

- (a) Install the 2 delivery pipe No. 1 spacers onto the cylinder head.

NOTICE:

Install delivery pipe No. 1 spacer in the correct direction.

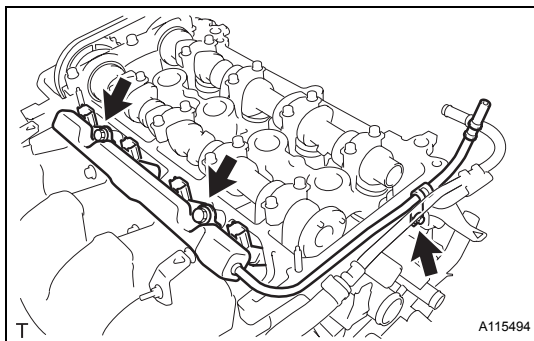
**45. INSTALL FUEL DELIVERY PIPE SUB-ASSEMBLY**

- (a) Provisionally install the fuel delivery pipe sub-assembly and 4 fuel injectors with the 3 bolts.

NOTICE:

- Do not drop the fuel injectors when installing the fuel delivery pipe sub-assembly.
- Check that the fuel injectors rotate smoothly after installing the fuel delivery pipe sub-assembly.

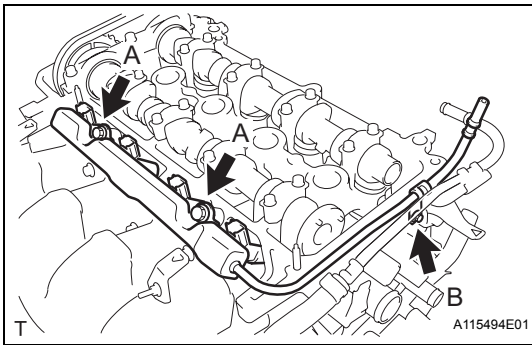

- (b) Tighten the 3 bolts to the specified torque.
Torque: 19 N*m (194 kgf*cm, 14 ft.*lbf) for bolt A
9.0 N*m (92 kgf*cm, 80 in.*lbf) for bolt B

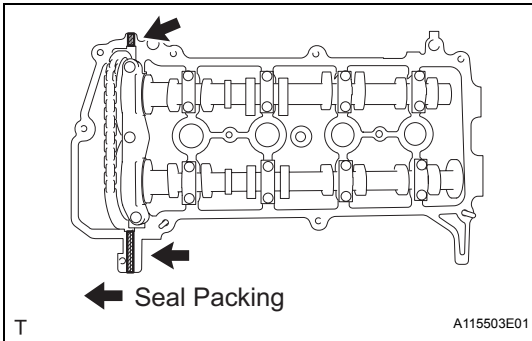

46. INSTALL CYLINDER HEAD COVER SUB-ASSEMBLY

- (a) Install the gasket onto the cylinder head cover.
 (b) Apply seal packing to the cylinder head, as shown in the illustration.

Seal Packing:

Toyota Genuine Seal Packing Black, Three Bond 1207B or Equivalent

NOTICE:

- Remove any oil from the contact surface.
 - Install the cylinder head cover sub-assembly within 3 minutes of applying the seal packing.
 - Do not start engine for at least 2 hours after the installation.
- (c) Install the cylinder head cover sub-assembly with the 9 bolts, 2 nuts and 2 seal washers.
 (d) Tighten the 9 bolts and 2 nuts in the sequence shown in the illustration.

Torque: 10 N*m (102 kgf*cm, 7.0 ft.*lbf)

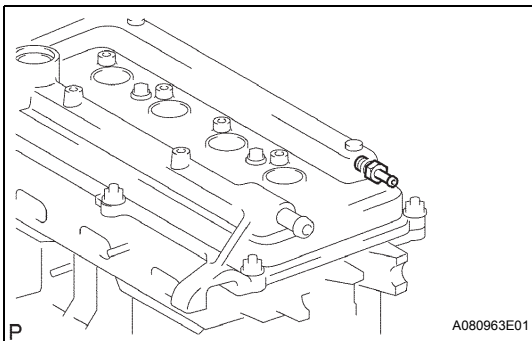
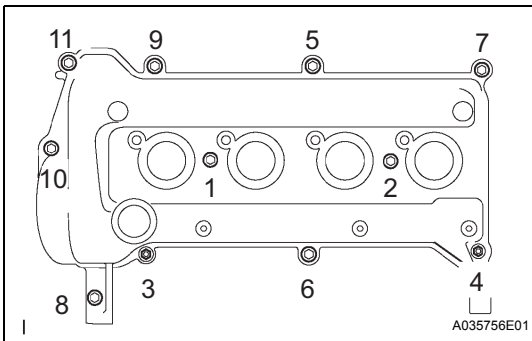

47. INSTALL VENTILATION VALVE SUB-ASSEMBLY

- (a) Install the ventilation valve onto the cylinder head cover.

Torque: 27 N*m (275 kgf*cm, 20 ft.*lbf)

48. INSTALL OIL LEVEL GAUGE GUIDE

- (a) Apply engine oil to a new O-ring.
 (b) Install the oil level gauge guide with the bolt.

Torque: 9.0 N*m (92 kgf*cm, 80 in.*lbf)

49. INSTALL CRANKSHAFT POSITION SENSOR

- (a) Apply a light coat of engine oil to the O-ring on the crankshaft position sensor.

NOTICE:

If the O-ring is damaged, replace the crankshaft position sensor.

- (b) Install the crankshaft position sensor with the bolt.

Torque: 7.5 N*m (76 kgf*cm, 66 in.*lbf)

50. INSTALL OIL FILLER CAP GASKET

- (a) Install the oil filler cap gasket onto the oil filler cap.

51. INSTALL OIL FILLER CAP SUB-ASSEMBLY

- (a) Install the oil filler cap onto the cylinder head cover.

52. INSTALL THERMOSTAT

- (a) Install a new gasket onto the thermostat.
 (b) Install the thermostat with the jiggle valve facing upward.

HINT:

The jiggle valve may be set within 10° either side as shown in the illustration.

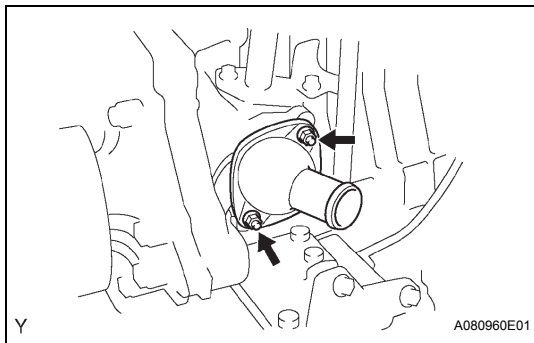
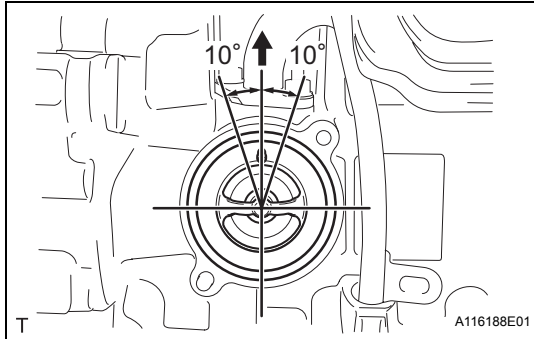
**53. INSTALL WATER INLET**

- (a) Install the water inlet with the 2 nuts.
Torque: 9.0 N*m (92 kgf*cm, 80 in.*lbf)

54. INSTALL ENGINE COOLANT TEMPERATURE SENSOR

- (a) Provisionally install the engine coolant temperature sensor through a new gasket.

- (b) Using SST, tighten the engine coolant temperature sensor.

SST 09817-33190

Torque: 20 N*m (204 kgf*cm, 15 ft.*lbf)

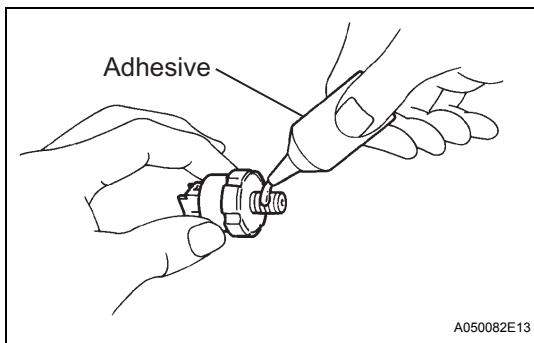
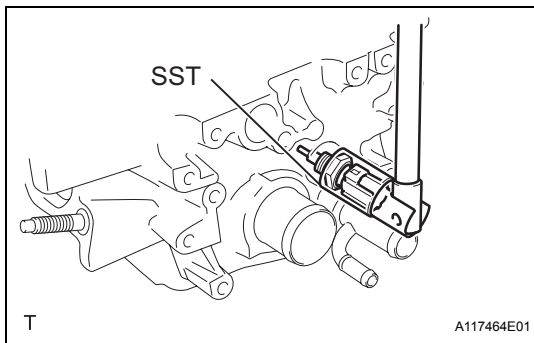
**55. INSTALL ENGINE OIL PRESSURE SWITCH ASSEMBLY**

- (a) Apply adhesive to the end 2 or 3 threads of the oil pressure switch.

Adhesive:

Toyota Genuine Adhesive 1324, Three Bond 1324 or Equivalent

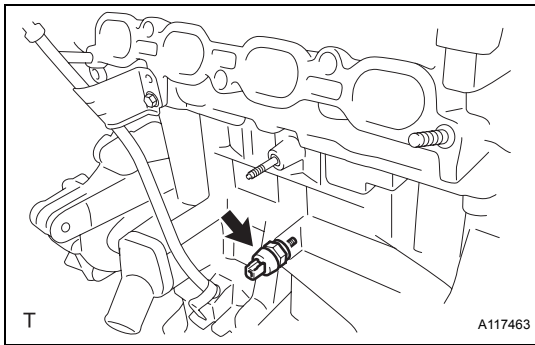

- (b) Using a 24 mm deep socket wrench, install the oil pressure switch.
Torque: 15 N*m (153 kgf*cm, 11 ft.*lbf)

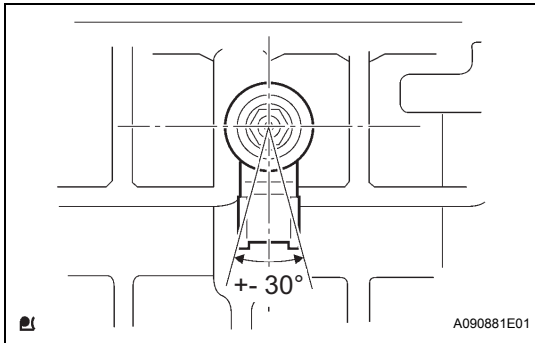

56. INSTALL KNOCK SENSOR

- (a) Install the knock sensor with the nut as shown in the illustration.
Torque: 20 N*m (204 kgf*cm, 15 ft.*lbf)

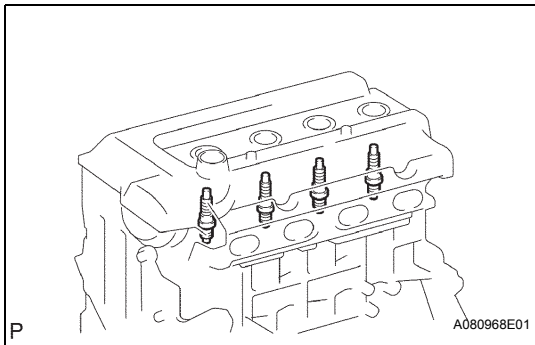

57. INSTALL SPARK PLUG

- (a) Using a spark plug wrench, install the spark plugs.
Torque: 18 N*m (184 kgf*cm, 13 ft.*lbf)