

ABS (ANTI-LOCK BRAKE SYSTEM)

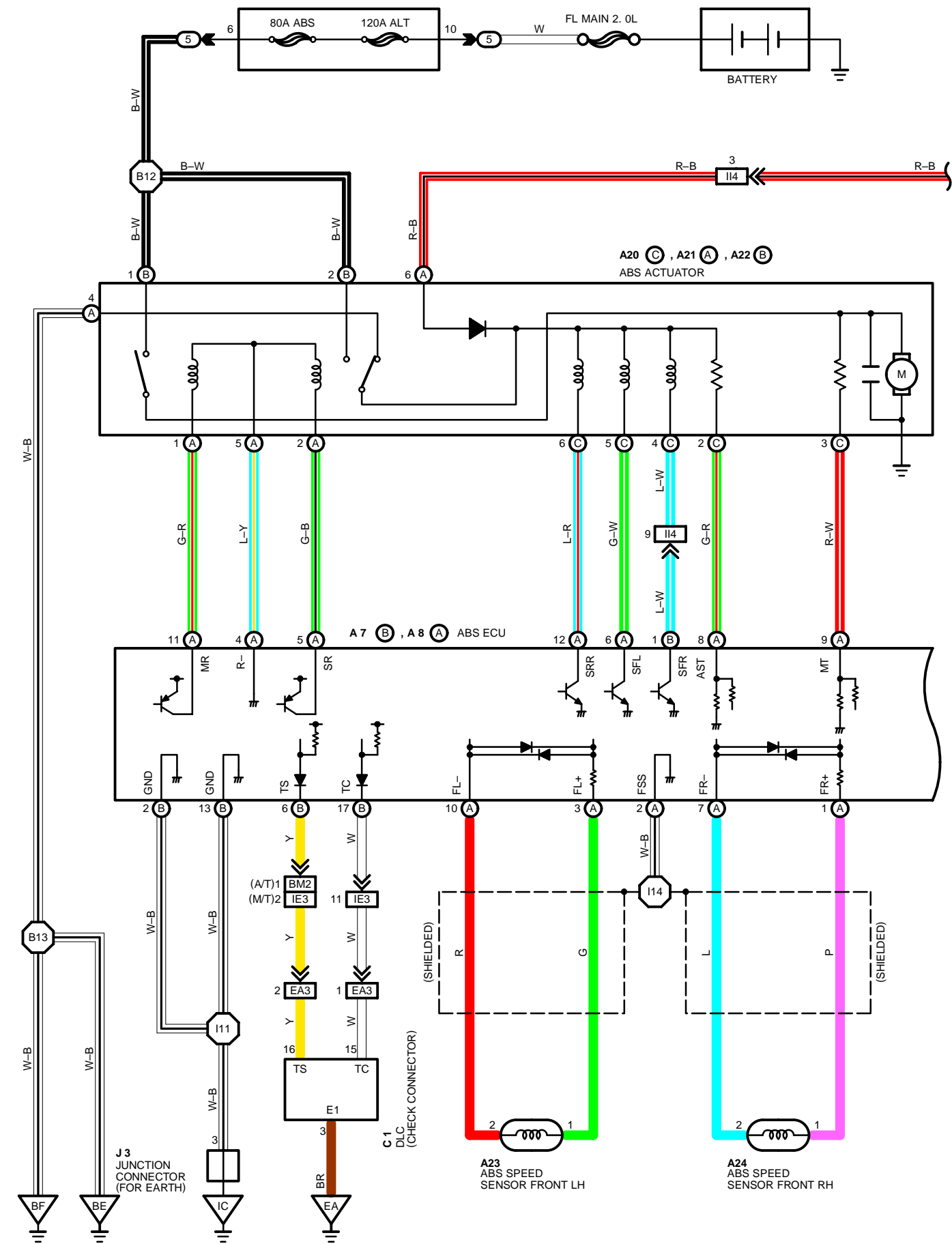

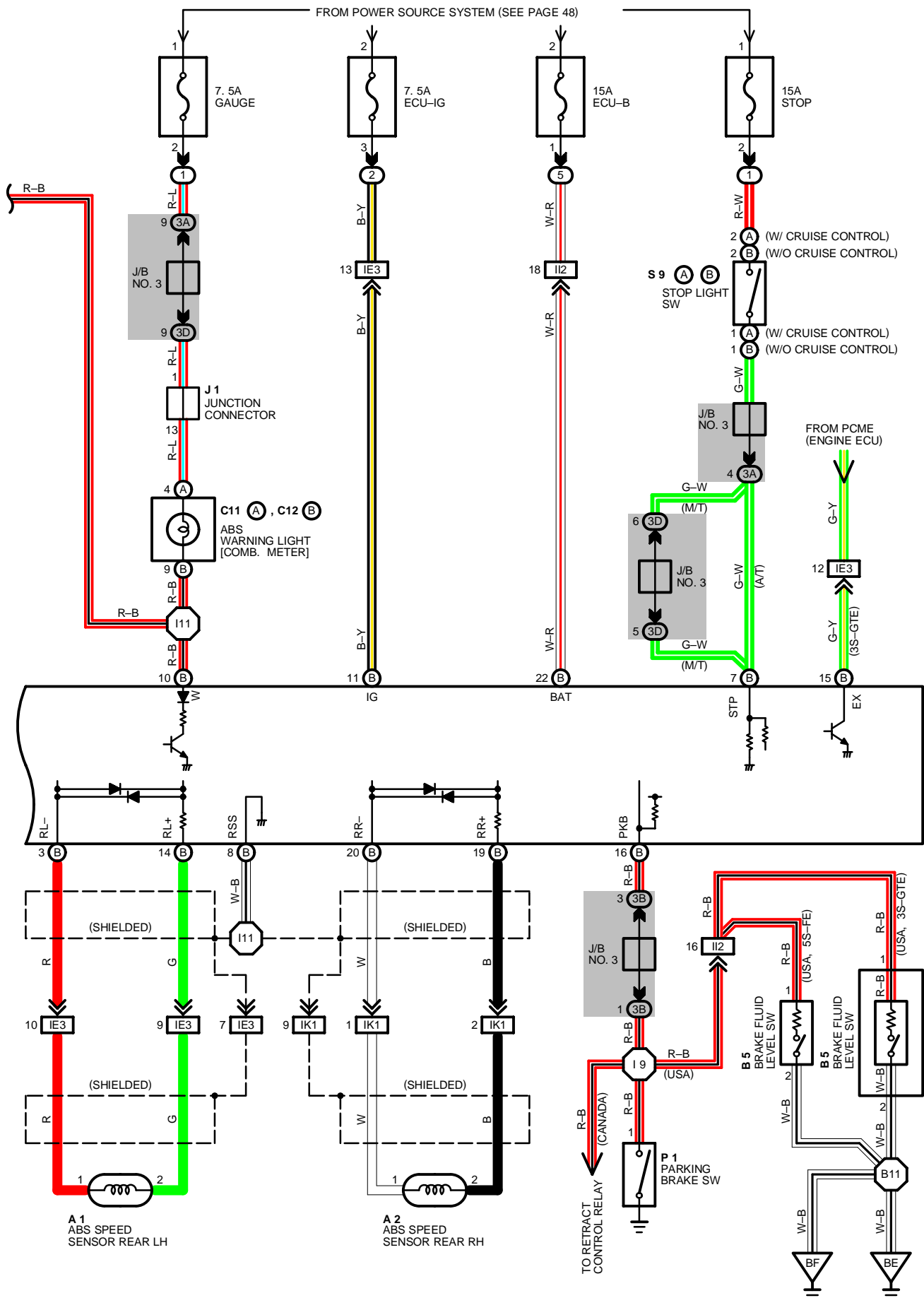

ABS (ANTI-LOCK BRAKE SYSTEM)

SYSTEM OUTLINE

THIS SYSTEM CONTROLS THE RESPECTIVE BRAKE FLUID PRESSURES ACTING ON THE DISC BRAKE CYLINDERS OF THE RIGHT FRONT WHEEL, LEFT FRONT WHEEL AND REAR WHEELS, WHEN THE BRAKES ARE APPLIED IN A PANIC STOP, SO THAT THE WHEELS DO NOT LOCK. THIS RESULTS IN IMPROVED DIRECTIONAL STABILITY AND STEERABILITY DURING PANIC BRAKING.

1. INPUT SIGNALS

(1) SPEED SENSOR SIGNAL

THE SPEED OF THE WHEELS IS DETECTED AND INPUT TO **TERMINALS FL+, FR+, RL+ AND RR+** OF THE ABS ECU.

(2) STOP LIGHT SW SIGNAL

A SIGNAL IS INPUT TO **TERMINAL STP** OF THE ABS ECU WHEN THE BRAKE PEDAL IS OPERATED.

(3) PARKING BRAKE SW SIGNAL

A SIGNAL IS INPUT TO **TERMINAL PKB** OF THE ABS ECU WHEN THE PARKING BRAKE IS OPERATED.

2. SYSTEM OPERATION

DURING SUDDEN BRAKING THE ABS ECU, WHICH HAS SIGNALS INPUT FROM EACH SENSOR, CONTROLS THE CURRENT FLOWING TO THE SOLENOID INSIDE THE ACTUATOR AND LETS THE HYDRAULIC PRESSURE ACTING ON EACH WHEEL CYLINDER ESCAPE TO THE RESERVOIR.

THE PUMP INSIDE THE ACTUATOR IS ALSO OPERATING AT THIS TIME AND IT RETURNS THE BRAKE FLUID FROM THE RESERVOIR TO THE MASTER CYLINDER, THUS PREVENTING LOCKING OF THE VEHICLE WHEELS.

IF THE ECU JUDGES THAT THE HYDRAULIC PRESSURE ACTING ON THE WHEEL CYLINDER IS INSUFFICIENT, THE CURRENT ACTING ON THE SOLENOID IS CONTROLLED AND THE HYDRAULIC PRESSURE IS INCREASED. HOLDING OF THE HYDRAULIC PRESSURE IS ALSO CONTROLLED BY THE ECU IN THE SAME METHOD AS ABOVE. BY REPEATED PRESSURE REDUCTION, HOLDING AND INCREASE ARE REPEATED TO MAINTAIN VEHICLE STABILITY AND TO IMPROVE STEERABILITY DURING SUDDEN BRAKING.

SERVICE HINTS

A7(B), A 8(A) ABS ECU

(CONNECT THE ECU CONNECTOR)

(B) 6–GROUND: APPROX. 12 VOLTS WITH IGNITION SW AT **ON** POSITION AND CHECK CONNECTOR **TS–E1** NOT CONNECTED

(B) 10–GROUND: APPROX. 12 VOLTS WITH IGNITION SW AT **ON** POSITION AND CHECK CONNECTOR **TS–E1** NOT CONNECTED

(B) 1–GROUND, **(A) 6**–GROUND: APPROX. 12 VOLTS WITH IGNITION SW AT **ON** POSITION, ABS WARNING LIGHT GOES OFF

(A) 8–GROUND, **(A) 12**–GROUND: APPROX. 12 VOLTS WITH IGNITION SW AT **ON** POSITION, ABS WARNING LIGHT GOES OFF

(B) 15–GROUND: APPROX. 12 VOLTS WITH IGNITION SW AT **ON** POSITION, ABS WARNING LIGHT GOES OFF

(B) 2–GROUND: ALWAYS CONTINUITY

(B) 13–GROUND: ALWAYS CONTINUITY

(B) 11–GROUND: APPROX. 12 VOLTS WITH IGNITION SW AT **ON** POSITION

(B) 7–GROUND: APPROX. 12 VOLTS WITH BRAKE PEDAL DEPRESSED

(B) 22–GROUND: ALWAYS APPROX. 12 VOLTS

(B) 16–GROUND: APPROX. 12 VOLTS WITH ENGINE RUNNING AND PARKING BRAKE LEVER RELEASED

(DISCONNECT THE ECU CONNECTOR)

(B) 1 – **(A) 8** : APPROX. 6 Ω

(A) 6 – **(A) 8** : APPROX. 6 Ω

(A) 8 – **(A) 12**: APPROX. 6 Ω

(A) 7 – **(A) 1** : APPROX. 0.8 – 1.3 Ω

(A) 3 – **(A) 10** : APPROX. 0.8 – 1.3 Ω

(A) 4 – **(A) 5** : APPROX. 60 – 100 Ω

(A) 4 – **(A) 11** : APPROX. 50 – 80 Ω

(B) 3 – **(B) 14** : APPROX. 1.1 – 1.5 K Ω

(B) 19 – **(B) 20** : APPROX. 1.1 – 1.5 K Ω

○ : PARTS LOCATION

CODE		SEE PAGE	CODE		SEE PAGE	CODE		SEE PAGE
A 1		24 (5S-FE), 25 (3S-GTE)	A22	B	27	C12	B	26
A 2		24 (5S-FE), 25 (3S-GTE)	A23		27	J 1		26
A 7	B	26	A24		27	J 3		26
A 8	A	26	B 5		27	P 1		26
A20	C	27	C1		24 (5S-FE), 25 (3S-GTE)	S 9	A	26
A21	A	27	C11	A	26		B	26

○ : RELAY BLOCKS

CODE	SEE PAGE	RELAY BLOCKS (RELAY BLOCK LOCATION)
1	20	R/B NO. 1 (LEFT KICK PANEL)
2	21	R/B NO. 2 (ENGINE COMPARTMENT LEFT)
5	21	R/B NO. 5 (FRONT LUGGAGE COMPARTMENT RIGHT)

○ : JUNCTION BLOCK AND WIRE HARNESS CONNECTOR

CODE	SEE PAGE	JUNCTION BLOCK AND WIRE HARNESS (CONNECTOR LOCATION)
3A	22	COWL WIRE AND J/B NO. 3 (BEHIND COMBINATION METER)
3B		
3D		

□ : CONNECTOR JOINING WIRE HARNESS AND WIRE HARNESS

CODE	SEE PAGE	JOINING WIRE HARNESS AND WIRE HARNESS (CONNECTOR LOCATION)
EA3	28 (5S-FE)	ENGINE WIRE AND ENGINE ROOM MAIN WIRE (R/B NO. 2 INNER)
	30 (3S-GTE)	
IE3	32	ENGINE ROOM MAIN WIRE AND COWL WIRE (LEFT KICK PANEL)
II2	34	LUGGAGE ROOM WIRE AND COWL WIRE (RIGHT KICK PANEL)
II4	34	COWL WIRE AND LUGGAGE ROOM WIRE (RIGHT KICK PANEL)
IK1	34	FLOOR WIRE AND COWL WIRE (RIGHT KICK PANEL)
BM2	36	COWL WIRE AND ENGINE ROOM MAIN WIRE (ROOM PARTITION BOARD LEFT)

▽ : GROUND POINTS

CODE	SEE PAGE	GROUND POINTS LOCATION
EA	28 (5S-FE)	INTAKE MANIFOLD
	30 (3VZ-FE)	
IC	32	INSTRUMENT PANEL BRACE LH
BE	36	FRONT RIGHT FENDER
BF	36	FRONT LEFT FENDER

○ : SPLICE POINTS

CODE	SEE PAGE	WIRE HARNESS WITH SPLICE POINTS	CODE	SEE PAGE	WIRE HARNESS WITH SPLICE POINTS
I 9	34	COWL WIRE	B11	36	LUGGAGE ROOM WIRE
I11			B12		
I14			B13		

ABS (ANTI-LOCK BRAKE SYSTEM)

A 1 GRAY



A 2 GRAY



A 7 (B) DARK GRAY

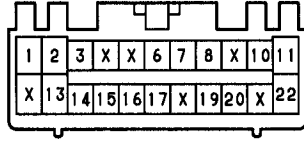

A 8 (A) DARK GRAY

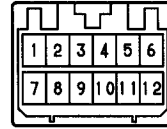

A20 (C) GRAY

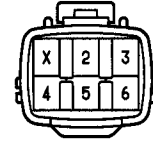

A21 (A) GRAY



A22 (B) GRAY

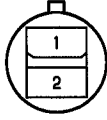

A23, A24 GRAY



B 5 GRAY

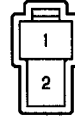

C 1 DARK GRAY

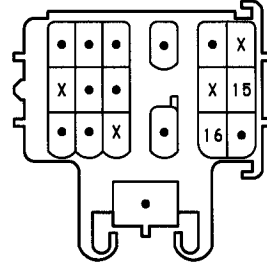

C11 (A) BLUE

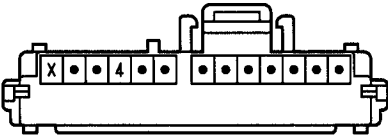

C12 (B) GRAY

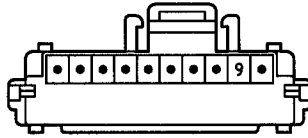

J 1

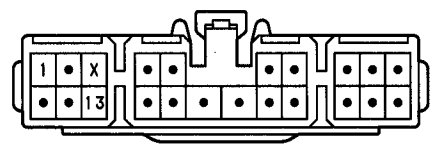

J 3

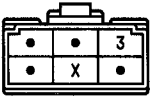

P 1



S 9 (A) BLUE

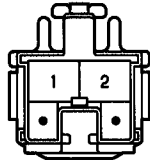

S 9 (B)

