

# POWERTRAIN CONTROL MODULE ENGINE (PCME) PCME FOR REMOVAL AND INSTALLATION

EG028-02

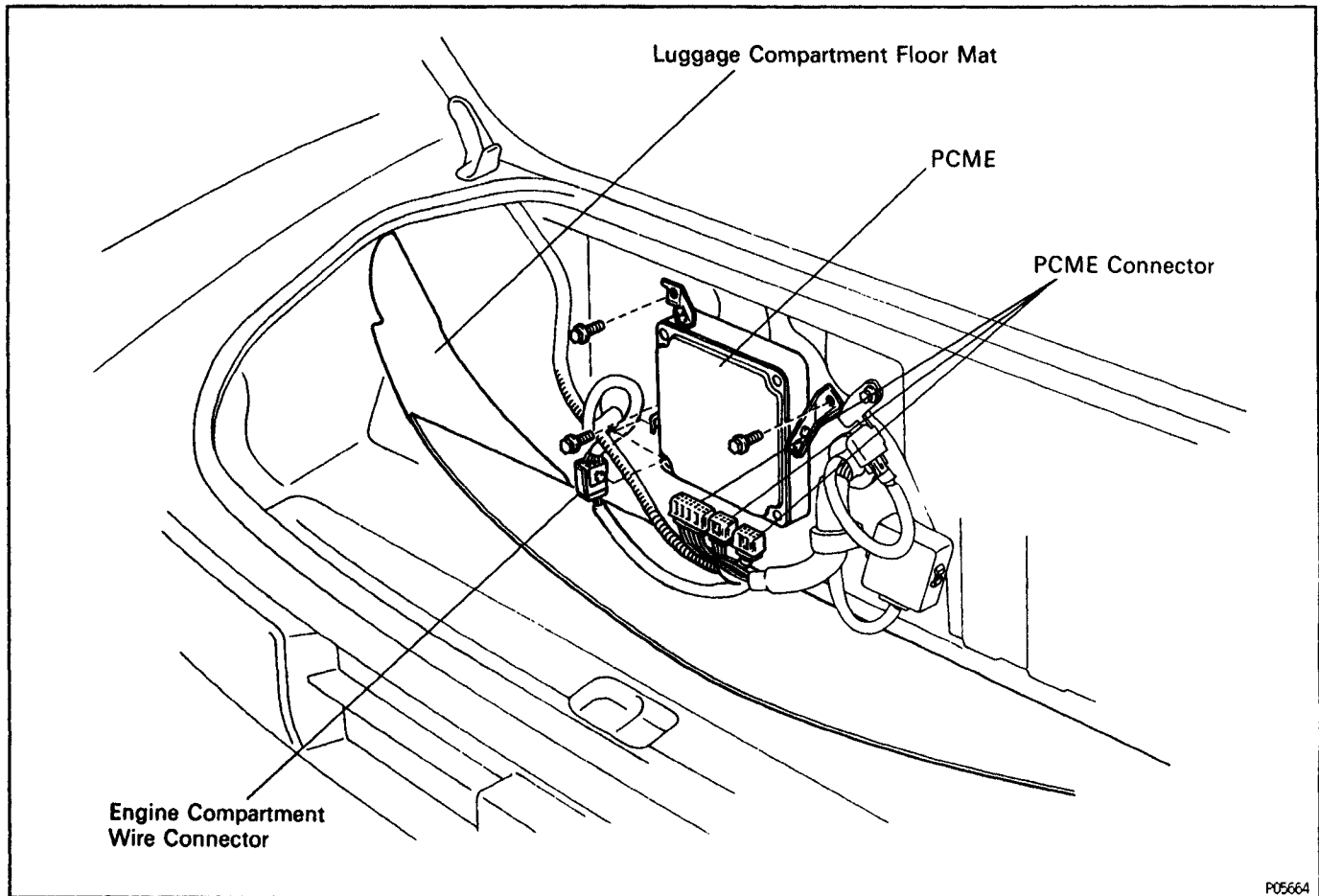

P05664

## PCME INSPECTION

EG028-01

(See Components for Removal and Installation)

HINT: The SMPI circuit can be checked by measuring the resistance and voltage at the wiring connectors of the PCM E.

### 1. DISCONNECT FRONT SIDE OF LUGGAGE COMPARTMENT FLOOR MAT FROM PARTITION PANEL

### 2. PREPARATION

- Disconnect the three connectors from the PCME.
- Remove the locks as shown in the illustration so that the tester probe(s) can easily come in.

**NOTICE:** Pay attention to sections A and B in the illustration which can easily be broken.

- Reconnect the three connectors to the PCME.

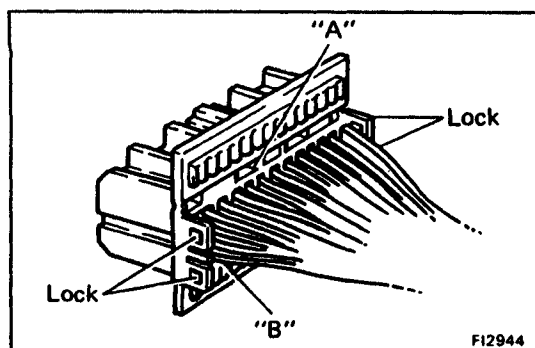

F12944

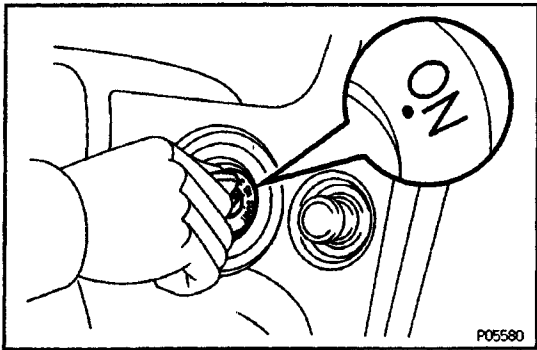

### 3. INSPECT VOLTAGE OF PCME

(a) Turn the ignition switch ON.

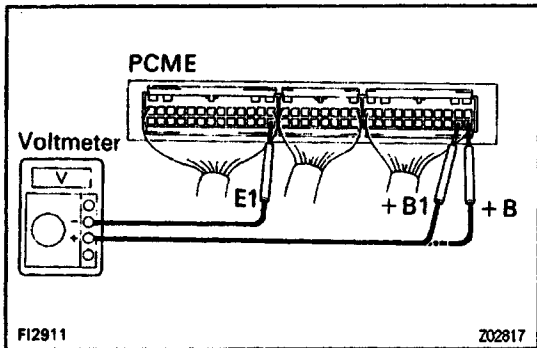

(b) Measure the voltage between each terminal of the wiring connectors.

HINT:

- Perform all voltage measurements with the connectors connected.
- Verify that the battery voltage is 11 V or more when the ignition switch is ON.

## Voltage at PCME Wiring Connectors

Terminals	Condition		STD voltage (V)
+ B + B1 - E1	IG SW ON		9 - 14
BATT - E1			9 - 14
IDL - E2	IG SW ON	Throttle valve open	9 - 14
VTA - E2		Throttle valve fully closed (Throttle opener must be cancelled first)	0.3 - 0.8
VC - E2		Throttle valve fully open	3.2 - 4.9
VS - E2		Measuring plate fully closed	4.5 - 5.5
		Measuring plate fully open	4.0 - 5.5
		Idling	0.2 - 0.5
	3,000 rpm	1.6 - 4.1	
#1 #2 - E01 #3 - E02 #4	IG SW ON Throttle valve fully closed (Throttle opener must be cancelled first)		1.0 - 2.0
THA - E2	IG SW ON	Intake air temp. 20°C (68°F)	9 - 14
THW - E2		Coolant temp. 80°C (176°F)	0.5 - 3.4
STA - E1	Cranking		0.2 - 1.0
IGT - E1	Idling		6 V or more
RSC RSO - E1	IG SW ON	PCME connectors disconnected	Pulse generation
W - E1	No trouble ("CHECK" engine warning light off) and engine running		9 - 14
PIM - E2	IG SW ON		2.5 - 4.5
AC - E1	IG SW ON	Air conditioning ON	9 - 14
*1TVIS - E1		Throttle valve fully closed (Throttle opener must be cancelled first)	2.0 or less
		Throttle valve open	9 - 14
*2TVIS - E1	Idling		2.0 or less
	4,200 rpm or more		9 - 14
TE1 - E1	IG SW ON	DLC1 TE1-E1 Not connected	9 - 14
		DLC1 TE1-E1 connected	0.5 or less

**PCME Terminals**

\*1w/ Regulator Gasoline  
\*2w/ Premium Gasoline

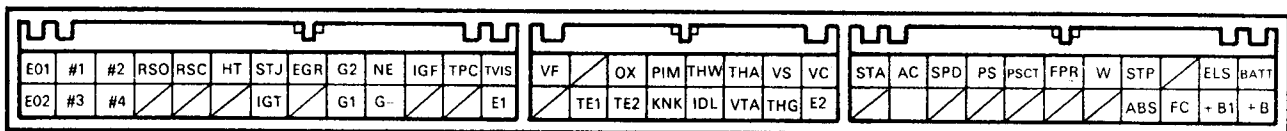

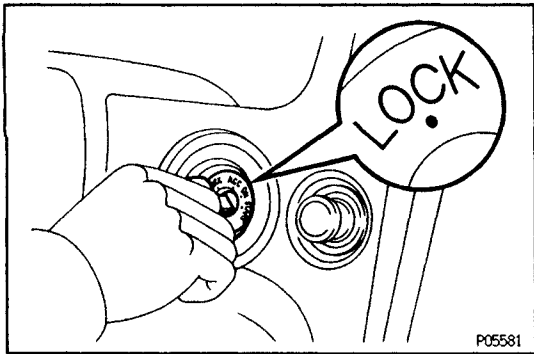

**4. INSPECT RESISTANCE OF PCME**

- (a) Turn the ignition switch OFF.
- (b) Disconnect the three connectors from the PCME.

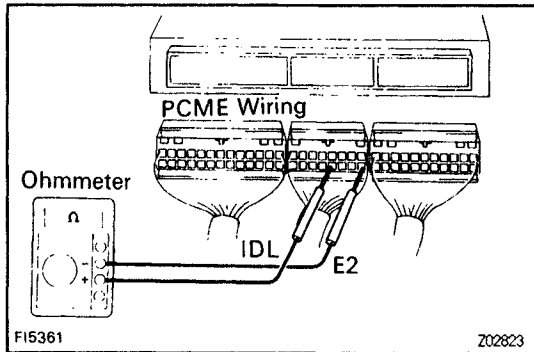

- (c) Measure the resistance between each terminal of the wiring connectors.

**NOTICE:**

- Do not touch the PCME terminals.
- The tester probe should be inserted in the wiring connector from the wiring side.

**Resistance of PCME Wiring Connectors**

Terminals	Condition	STD resistance (Ω)
IDL - E2	Throttle valve open	Infinity
	Throttle valve fully closed (Throttle opener must be cancelled first)	2,300 or less
VTA - E2	Throttle valve fully open	2,000 - 10,200
	Throttle valve fully closed (Throttle opener must be cancelled first)	200 - 5,700
VC - E2	Measuring plate fully closed	2,500 - 5,900
VS - E2		200 - 600
	Measuring plate fully open	20 - 1,200
THA - E2	Intake air temp. 20°C (68°F)	2,000 - 3,000
THW - E2	Coolant temp. 80°C (176°F)	200 - 400
G1 - G-	Cold (-10°C (14°F) to 50°C (104°F))	125 - 200
	Hot (50°C (104°F) to 100°C (212°F))	160 - 235
NE - G-	Cold (-10°C (14°F) to 50°C (104°F))	155 - 250
	Hot (50°C (104°F) to 100°C (212°F))	190 - 290
RSC - + B RSO - + B1		17.7 - 23.9

PCM E Terminals

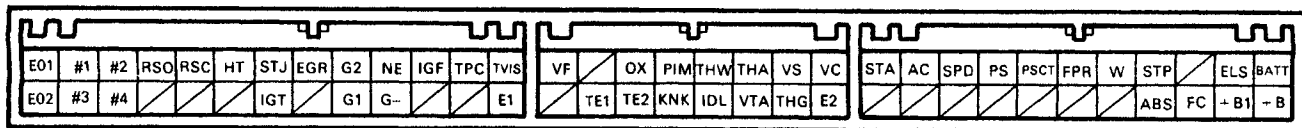

F12796