

# TROUBLESHOOTING WITH VOLT OHMMETER

## HINT:

EG128-01

- The following troubleshooting procedures are designed for inspection of each separate system, and therefore the actual procedure may vary somewhat. However, troubleshooting should be performed while referring to the inspection methods described in this manual.
- Before beginning inspection, it is best to first make a simple check of the fuses, H-fuses, fusible link and the condition of the connectors.
- The following troubleshooting procedures are based on the supposition that the trouble lies in either a short or open circuit within the computer.
- If engine trouble occurs even though proper operating voltage is detected in the computer connector, then it can be assumed that the PCME(& T) is faulty and should be replaced.

## FUSES, H-FUSES AND FUSIBLE LINK LOCATION

EG128-01

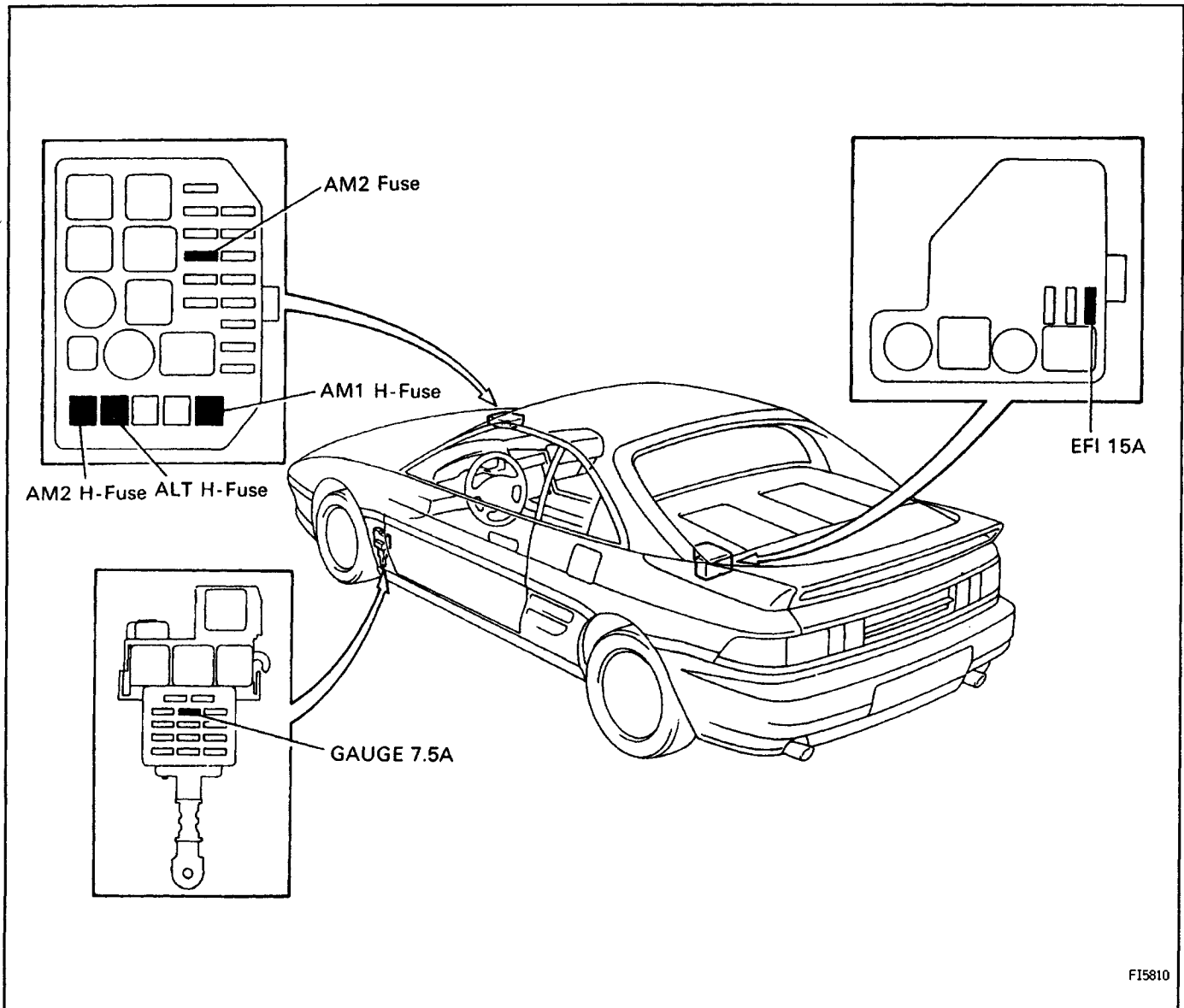

# MPI SYSTEM CHECK PROCEDURE (M/T)

## PREPARATION

- (a) Disconnect the connectors from the PCME.
- (b) Remove the locks as shown in the illustration so that the tester probe(s) can easily come in.

**NOTICE:** Pay attention to sections "A" and "B" in the illustration which can be easily broken.

- (c) Reconnect the connectors to the PCME.

### HINT:

- Perform all voltage measurements with the connectors connected.
- Verify that the battery voltage is 11 V or more when the ignition switch is in the "ON" position. Using a voltmeter with high impedance (10 kΩ/V minimum), measure the voltage at each terminal of the wiring connectors.

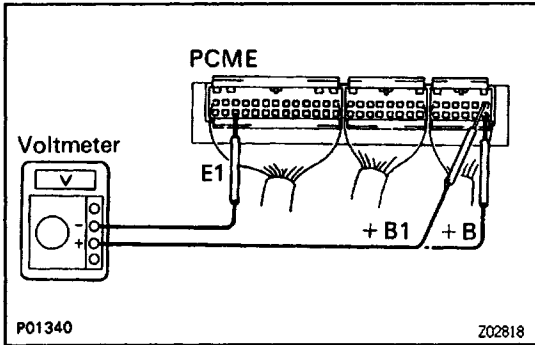
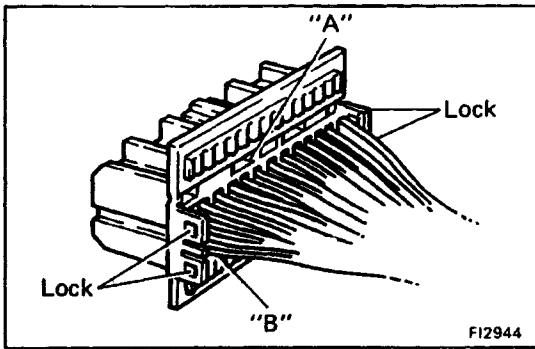

## PCME Terminals (M/T)

Symbol	Terminal Name	Symbol	Terminal Name	Symbol	Terminal Name
E01	POWER GROUND	NE +	DISTRIBUTOR	THA	INTAKE AIR TEMP. SENSOR
E02	POWER GROUND	NE -	DISTRIBUTOR	VC	MAP THROTTLE POSITION SENSOR
#10	INJECTOR	IGF	IGNITER	PIM	MAP
#20	INJECTOR	-	-	VTA	THROTTLE POSITION SENSOR
/	-	STA	STARTER RELAY	*OX2	SUB-OXYGEN SENSOR
E1	ENGINE GROUND	/	-	E2	SENSOR GROUND
ISCO	IDLE AIR CONTROL VALVE	ISCV	A/C IDLE-UP VSV	ACT	A/C AMPLIFIER
EGR	EG R VSV	FPU	FUEL PRESSURE VSV	ELS	TAILLIGHT RELAY DEFOGGER SWITCH
ISCC	IDLE AIR CONTROL VALVE	VF	DLC1	/	-
IGT	IGNITER	E21	SENSOR GROUND DLC1	SPD	VSPG
/	-	TE2	DLC1	FC	CIRCUIT OPENING RELAY
/	-	TE1	DLC1	/	-
PSCT	PS CONTROL MODULE	OX1	MAIN OXYGEN SENSOR	ACA	A/C AMPLIFIER
PS	PS CONTROL MODULE	THE	EVAPORATOR TEMP. SENSOR	/	-
/	-	KNK	KNOCK SENSOR	BATT	BATTERY
/	DISTRIBUTOR	*THG	EGR FUNCTION SENSOR	W	WARNING LIGHT
G +		THW	ECTS	+ B1	MPI MAIN RELAY
G -	DISTRIBUTOR	IDL	THROTTLE POSITION SENSOR	+ B	MPI MAIN RELAY

\*Calif. only

### PCME Terminals

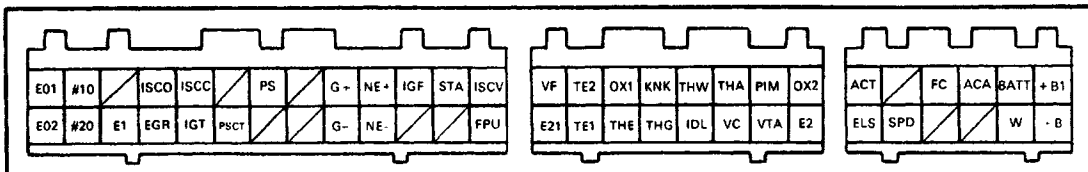

## PCME Wiring Connectors Voltage (M/T)

No.	Terminals	Condition	STD voltage (V)	See page
1	+ B + B1 - E1	IG SW ON	9 - 14	<a href="#">EG2-220</a>
2	BATT - E1	-	9 - 14	<a href="#">EG2-221</a>
3	IDL - E2	IG SW ON	Throttle valve open	9 - 14
	VC - E2		-	4.5 - 5.5
	VTA - E2		Throttle valve fully closed (Throttle opener must be cancelled first)	0.3 - 0.8
			Throttle valve fully open	3.2 - 4.9
4	PIM - E2	IG SW ON	3.3 - 3.9	<a href="#">EG2-224</a>
	VC - E2		4.5 - 5.5	
5	#10 - E01 #20 - E02			9 - 14
6	THA - E2	IG SW ON	Intake air temp. 20°C (68°F)	<a href="#">EG2-226</a>
7	THW - E2		Coolant temp. 80°C (176°F)	<a href="#">EG2-227</a>
8	STA - E1	Cranking	6 or more	<a href="#">EG2-228</a>
9	IGT - E1	Idling	Pulse generation	<a href="#">EG2-229</a>
10	ISCO - E1	IG SW ON	8 - 14	<a href="#">EG2-230</a>
11	W - E1	No trouble ("CHECK" engine warning light off) and engine running	9 - 14	<a href="#">EG2-231</a>

**PCME Terminals**

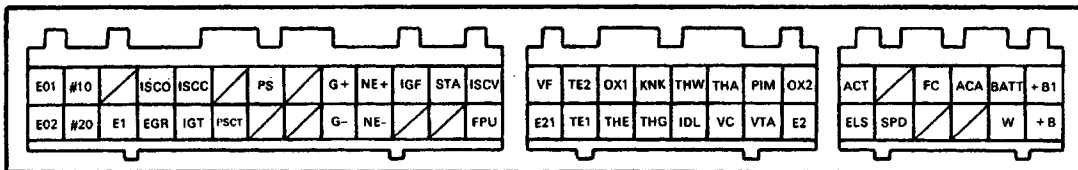

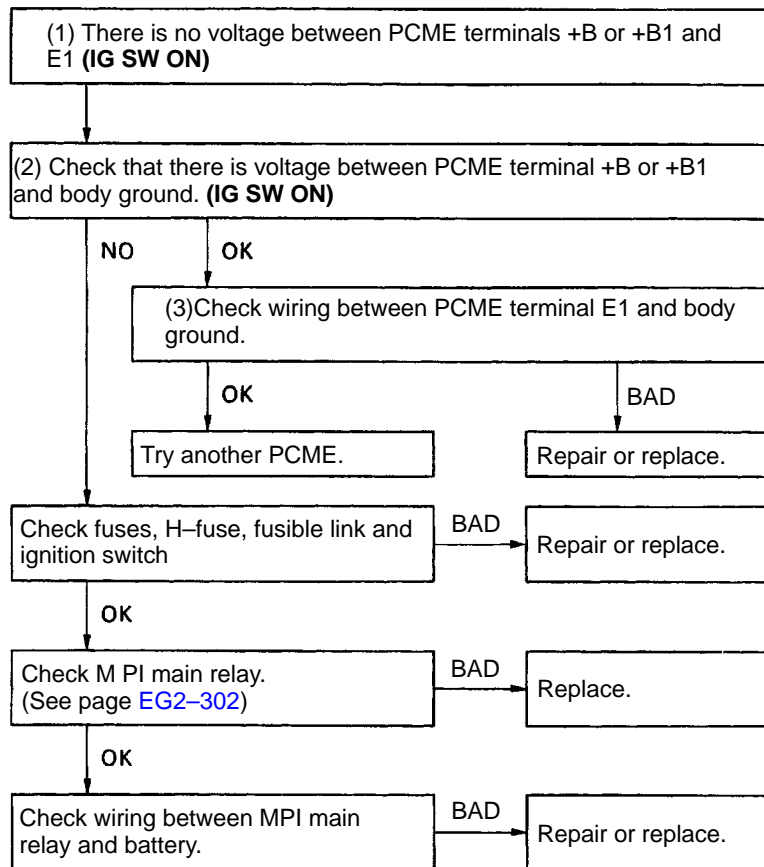
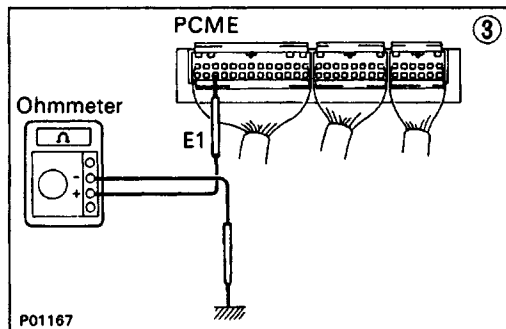
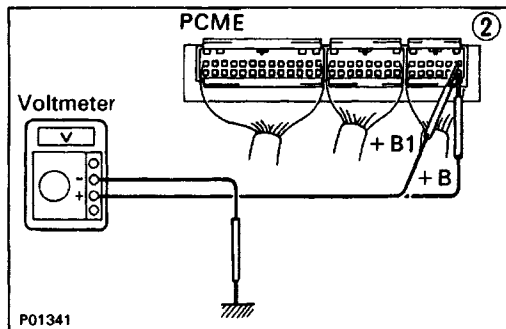
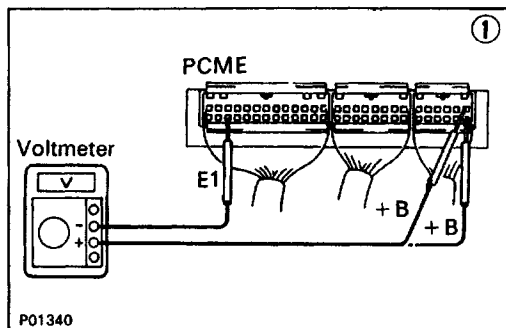
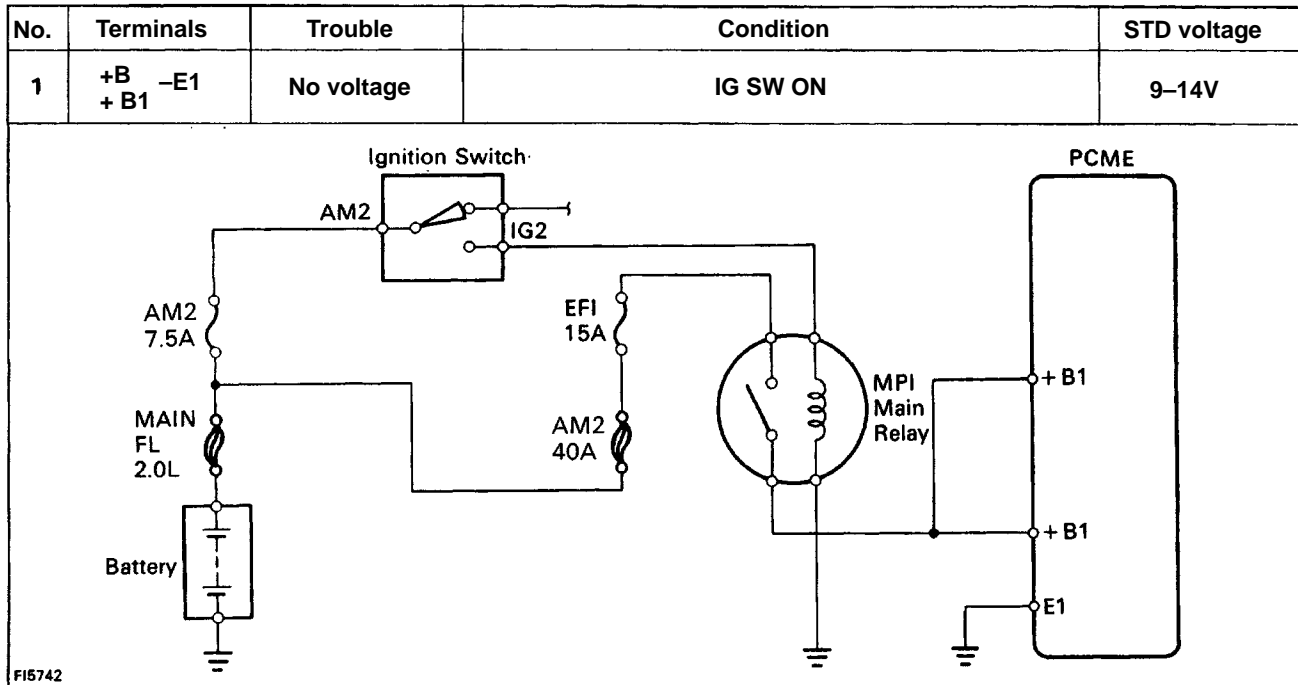

No.	Terminals	Trouble	Condition	STD voltage
2	BATT - E1	No voltage	-	9 - 14 V

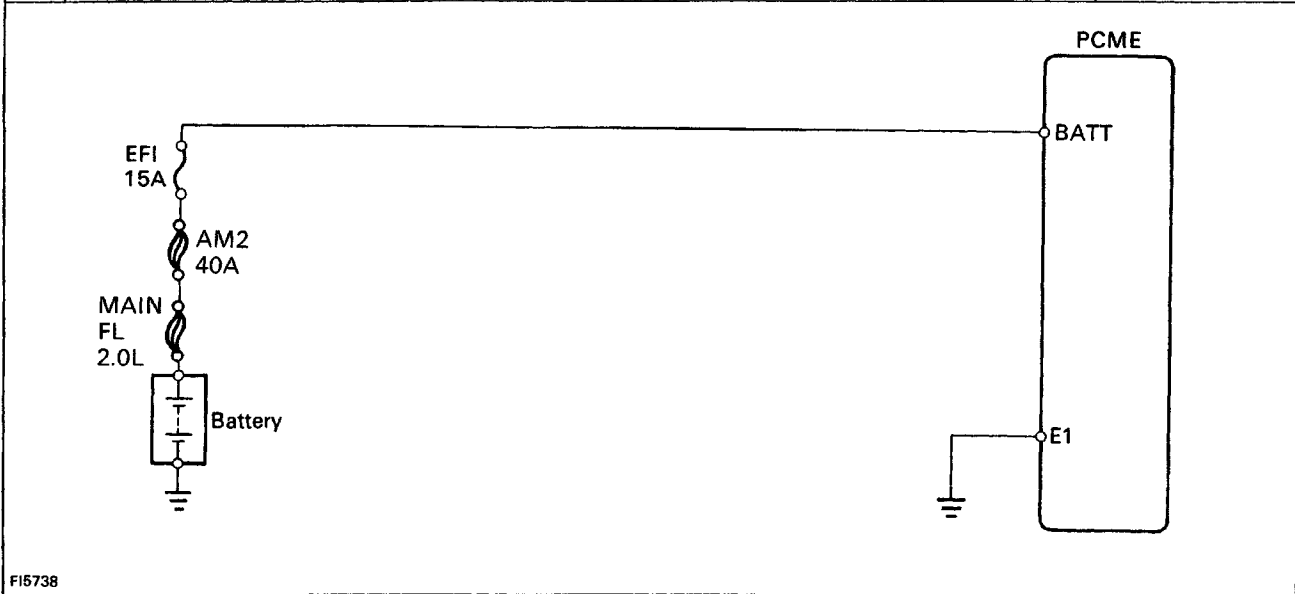

FI5738

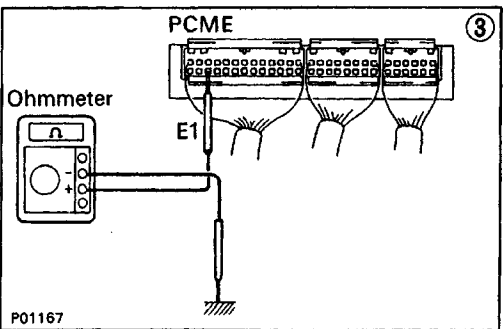
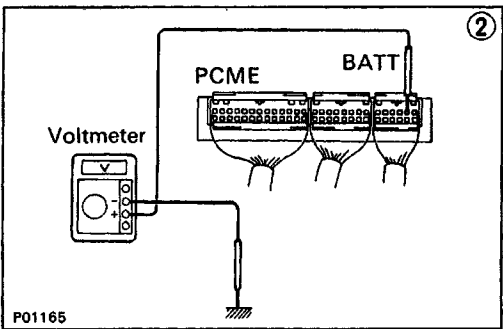
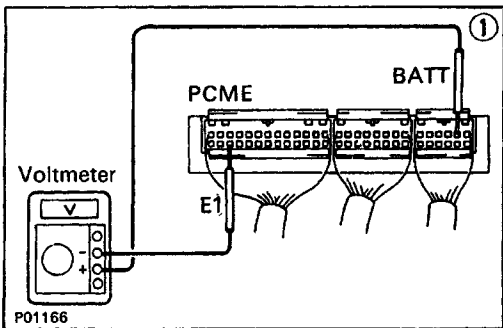

```

    graph TD
      A["(1) There is no voltage between PCME terminals BATT and E1."] --> B["(2) Check that there is voltage between PCME terminal BATT and body ground."]
      B -- NO --> C["Check fuse, H-fuse and fusible link."]
      B -- OK --> D["(3) Check wiring between PCME terminal E1 and bodground."]
      C -- BAD --> E["Replace."]
      C -- OK --> F["Check wiring between PCME terminal and battery."]
      D -- OK --> G["Try another PCME."]
      D -- BAD --> H["Repair or replace."]
      F -- BAD --> I["Repair or replace."]
      F -- OK --> G
  
```

No.	Terminals	Trouble	Condition	STD voltage	
3	ID - E2	No voltage	IG SW ON	Throttle valve open	9 - 14 V
	VC - E2			-	4.5 - 5.5 V
	VTA - E2			Throttle valve fully closed Throttle opener must be cancelled first	0.3 - 0.8 V
				Throttle valve fully open	3.2 - 4.9 V

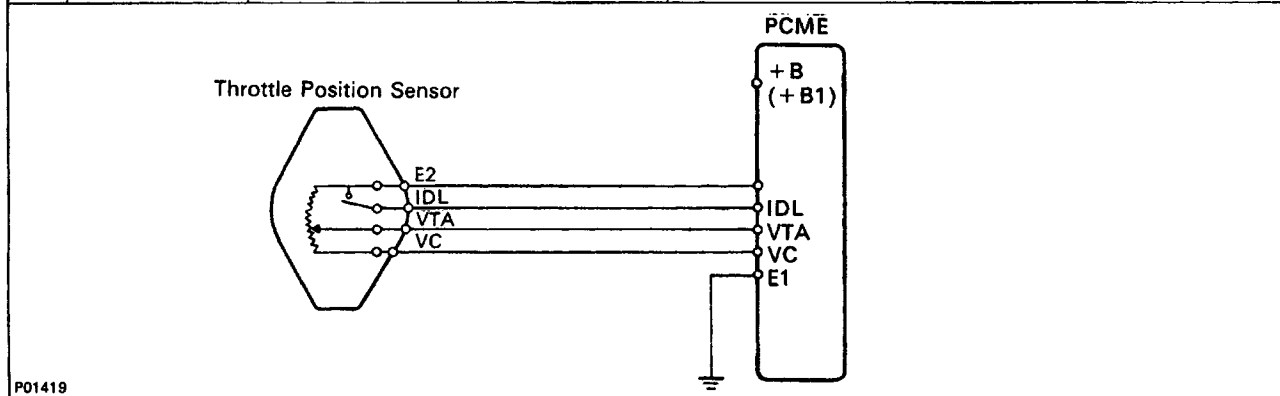

P01419

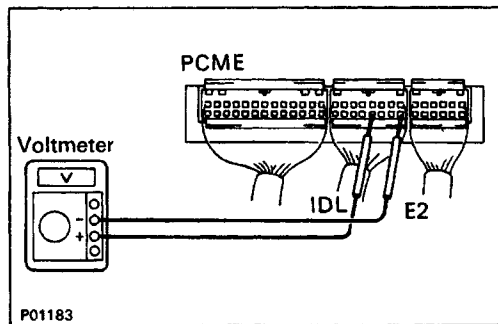

P01183

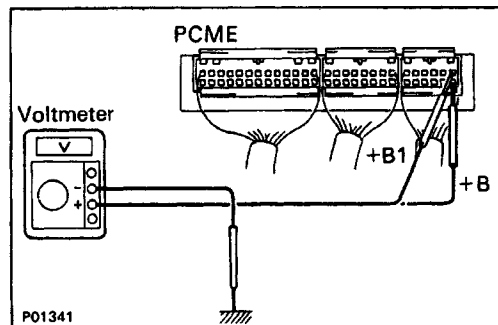

P01341

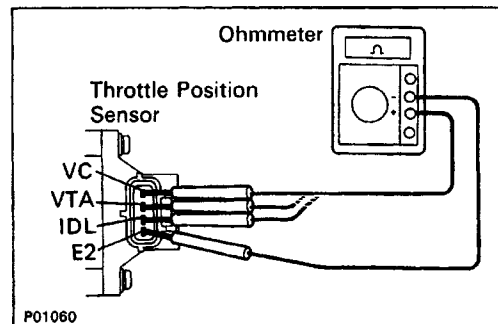

P01060

• IDL - E2

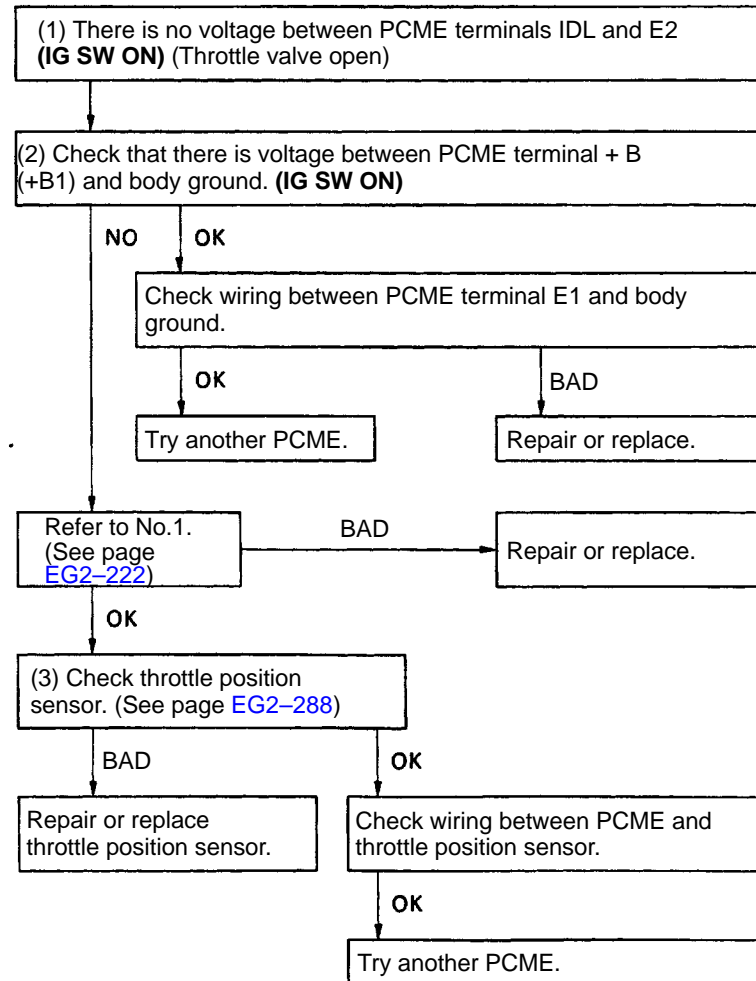

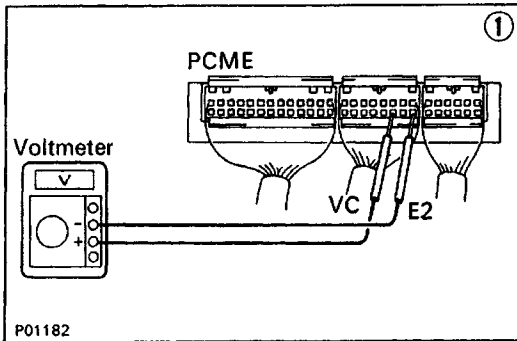

• VC-E2

(1) There is no voltage between PCME terminals VC and E2. (IG SW ON)

Check that there is voltage between PCME terminal + B (+B1) and body ground. (IG SW ON)

OK

NO

(2) Check throttle position sensor. (See page EG2-288)

Refer to No.1. (See page EG2-220)

BAD

OK

Repair or replace.

Check wiring between PCME and throttle position sensor.

OK

BAD

Try another PCME.

Repair or replace wiring.

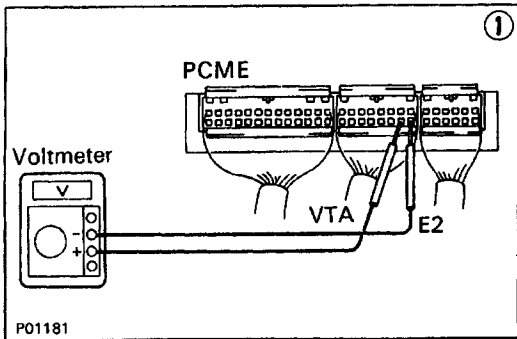
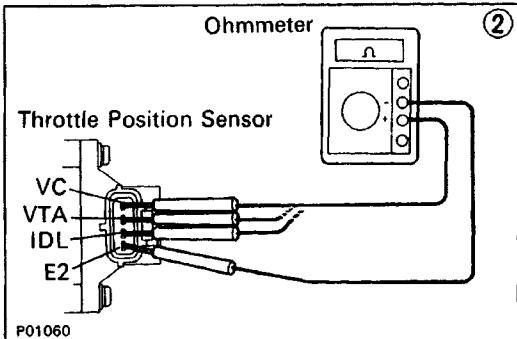

• VTA-E2

(1) There is no specified voltage at PCME terminals VTA and E2. (IG SW ON)

(2) Check that there is voltage between PCME terminals VC and E2. (IG SW ON)

NO

OK

Refer to VC-E2 trouble Section.

OK

Check throttle position sensor. (See page EG2-288)

BAD

Repair or replace.

OK

Check wiring between PCME and throttle position sensor.

BAD

Repair or replace.

OK

Try another PCME.

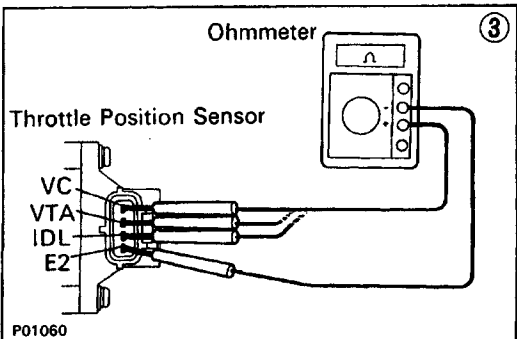
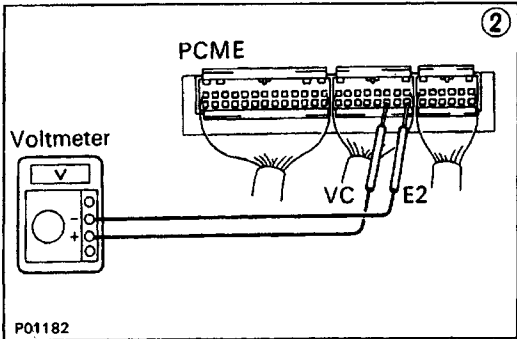

No.	Terminals	Trouble	Condition	STD voltage
4	PIM - E2	No voltage	IG SW ON	3.3 - 3.9 V
	VC - E2			4.5 - 5.5 V

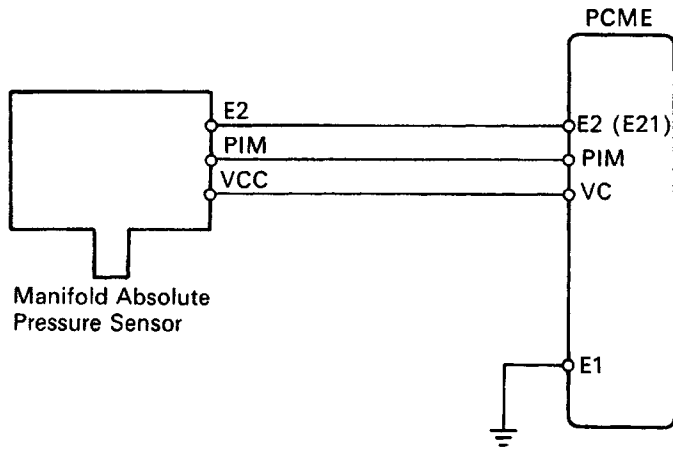

FI1226

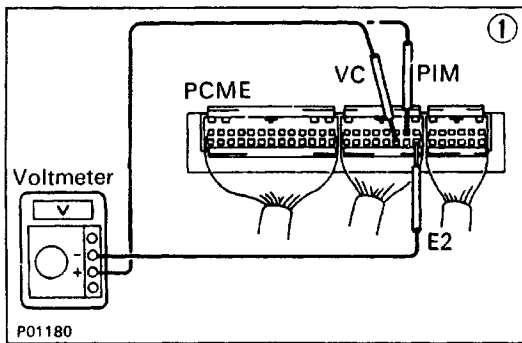

(1) There is no voltage between PCME terminals PIM or VC and E2. **(IG SW ON)**

(2) Check that there is voltage between PCME terminal + B (+B1) and body ground. **(IG SW ON)**

OK

NO

Refer to No.1.  
(See page EG2-220)

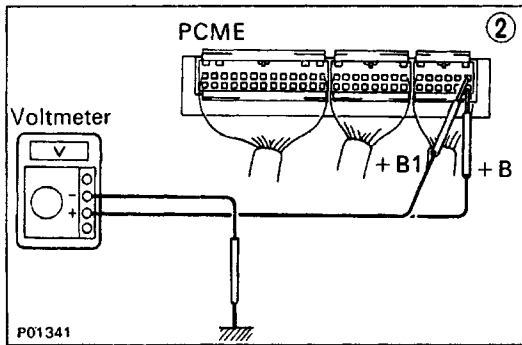

(3) Check wiring between PCME terminal E1 and body ground.

OK

BAD

Check manifold absolute pressure sensor. (See page EG2-319)

Repair or replace.

BAD

OK

Replace manifold absolute pressure sensor.

Check wiring between PCME and manifold absolute pressure sensor.

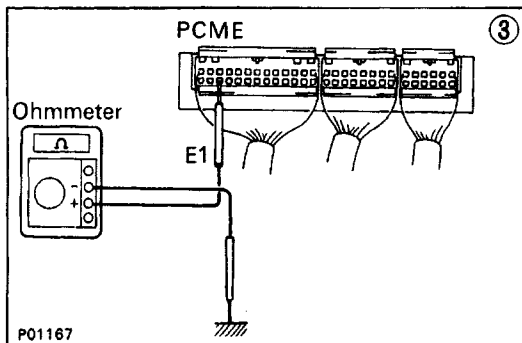

Try another PCME.

OK

BAD

Repair or replace.



No.	Terminals	Trouble	Condition	STD voltage
5	#10 - E01 #20 - E02	No voltage	IG SW ON	9 - 14 V

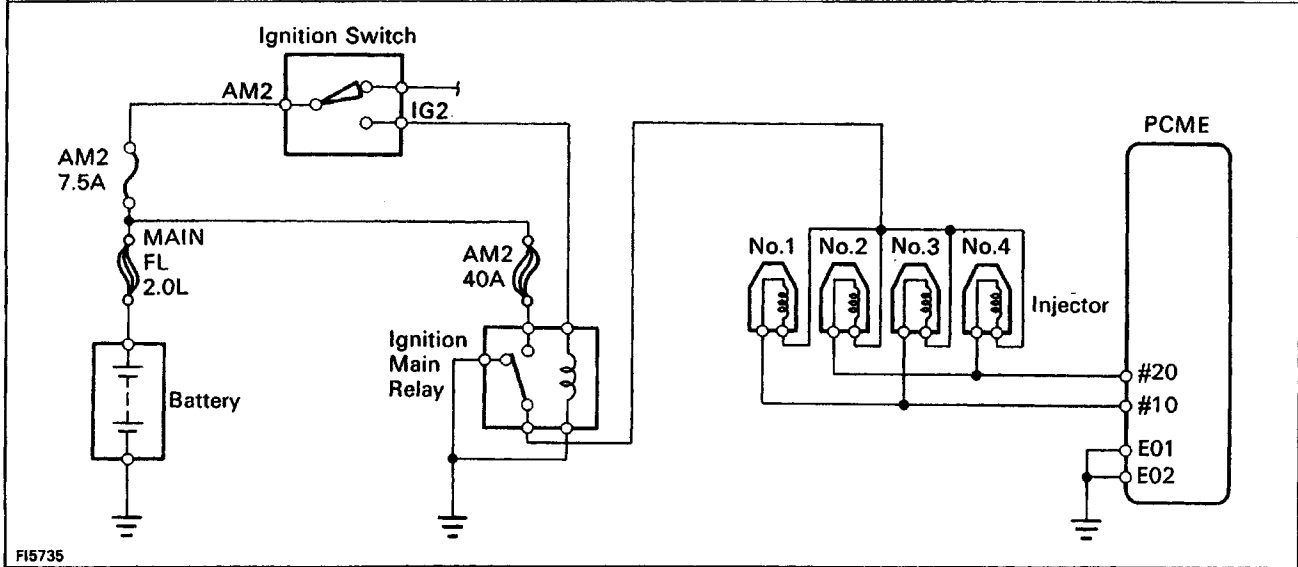

FI5735

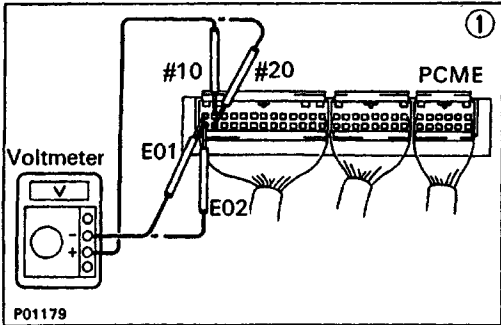

P01179

(1) There is no voltage between PCME terminals #10 and/or #20 and E01 and/or E02. (IG SW ON)

(2) Check that there is voltage between PCME terminal #10 and/or #20 and body ground.

NO

OK

Check wiring between PCME terminal E01 and/or E02 and body ground.

OK

BAD

Try another PCME.

Repair or replace.

Check fuse, H-fuse, fusible link, ignition switch and ignition main relay.

BAD

Repair or Replace.

OK

(3) Check resistance of each injector.  
STD resistance: Approx. 13.8Ω

OK

BAD

Replace injector.

Check wiring between PCME terminal No.10 and/or No.20 and battery.

BAD

Repair or replace.

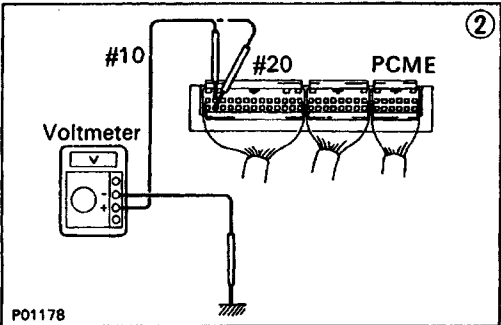

P01178

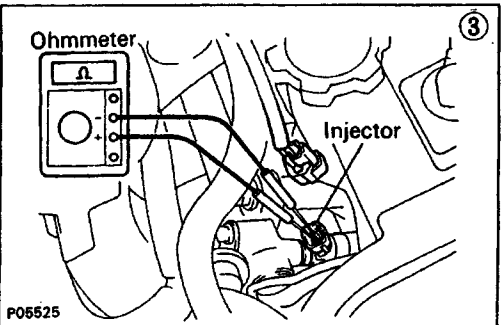

P05525

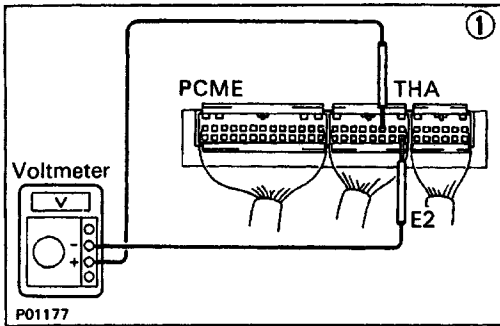
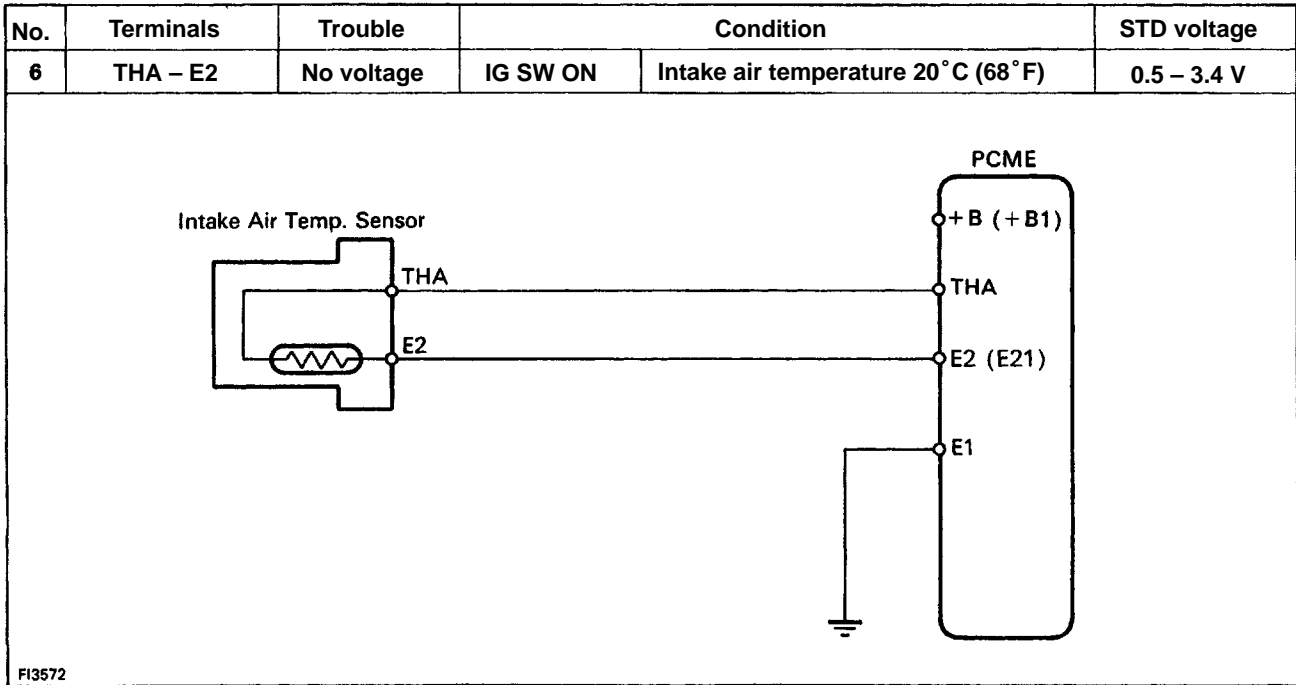

(1) There is no voltage between PCME terminals THA and E2 (IG SW ON)

(2) Check that there is voltage between PCME terminal + B or + B1 and body ground. (IG SW ON)

OK

NO

Refer to No. 1. (See page EG2-220)

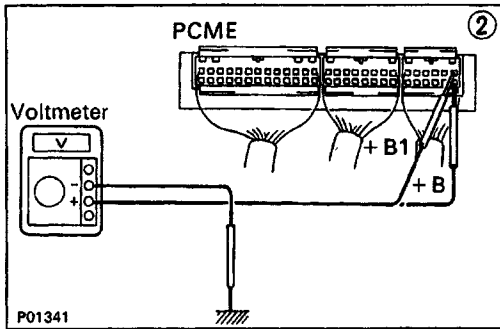

Check wiring between PCME terminal E1 and body ground.

OK

BAD

(3) Check intake air temp. sensor. (See page EG2-306)

Repair or replace.

BAD

Replace intake air temp. sensor.

OK

Check wiring between PCME and air temp. sensor.

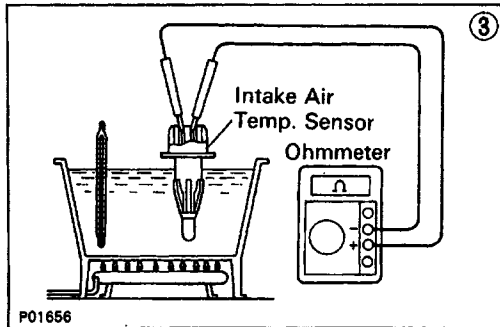

Try another PCME.

OK

BAD

Repair or replace.

No.	Terminals	Trouble	Condition		STD voltage
7	THW - E2	No voltage	IG SW ON	Coolant temperature 80°C (176°F)	0.2 - 1.0 V

Engine Coolant Temp. Sensor

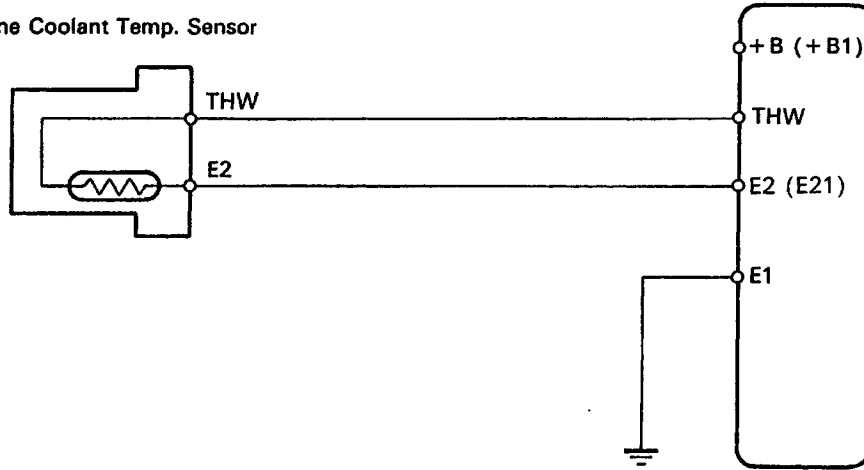

FI3572

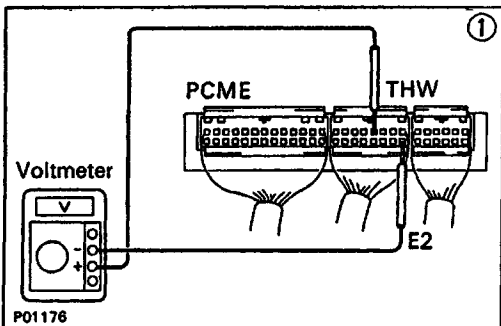

(1) There is no voltage between PCME terminals THW and E2. (IG SW ON)

(2) Check that there is voltage between PCME terminal + B (+B1) and body ground. (IG SW ON)

OK

NO

Refer to No.1. (See page EG2-220)

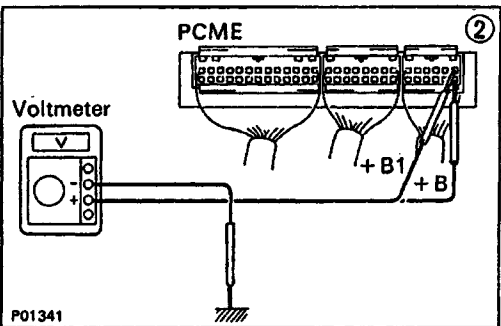

Check wiring between PCME terminal E1 and body ground.

OK

BAD

Repair or replace.

(3) Check engine coolant temp. sensor. (See page EG2-305)

BAD

OK

Repair engine coolant temp. sensor.

Check wiring between PCME and engine coolant temp. sensor.

Try another PCME.

Repair or replace.

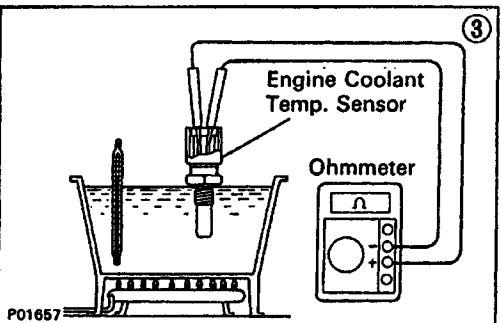

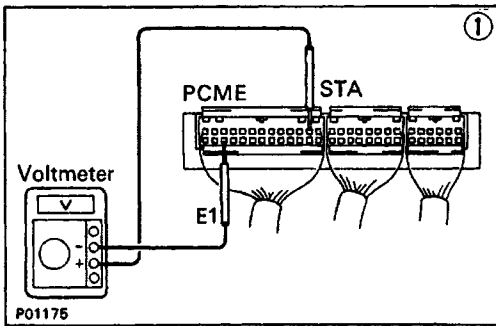
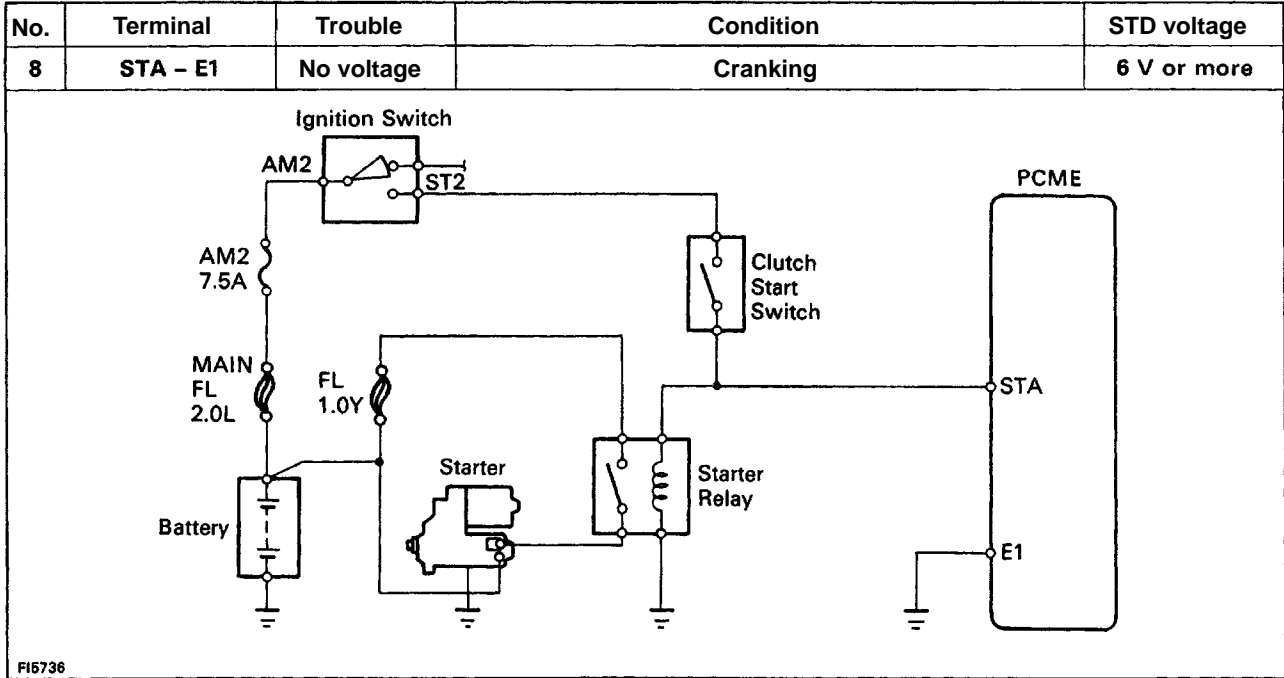

(1) There is no voltage between PCME terminals STA and E1. (IG SW ON)

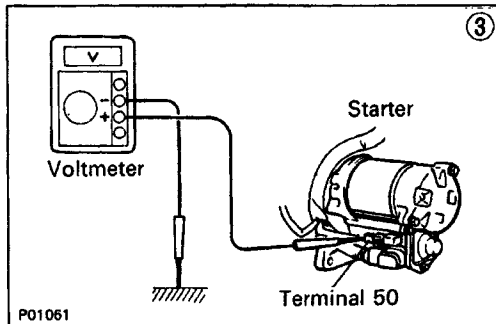
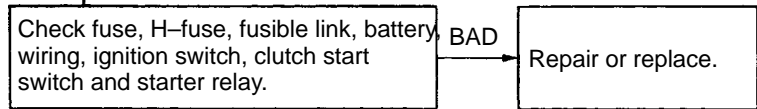
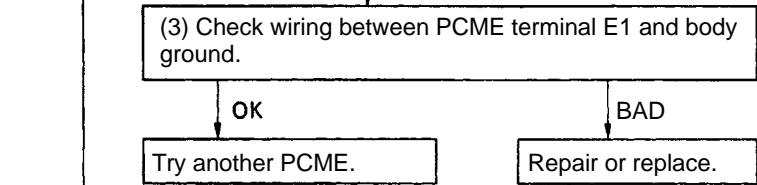
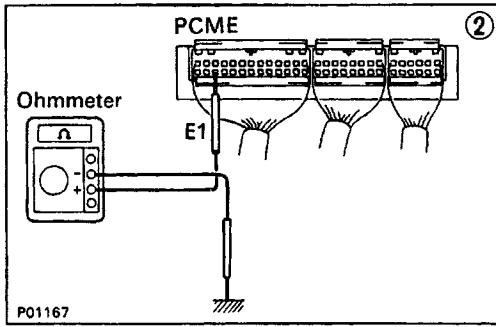
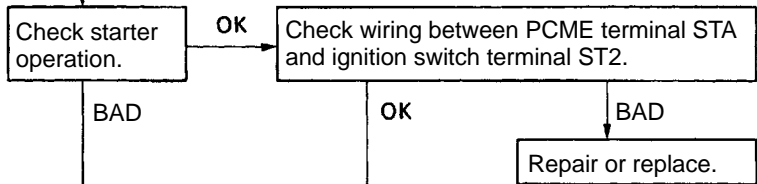

(3) Check that there is voltage at starter terminal 50. (IG SW START) STD voltage: 6 V or more

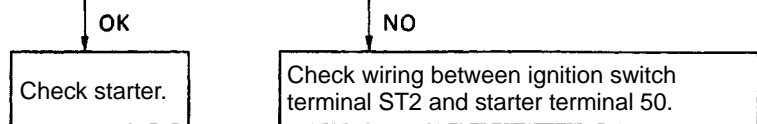

No.	Terminals	Trouble	Condition	STD voltage
9	IGT - E1	No voltage	Idling	Pulse generation

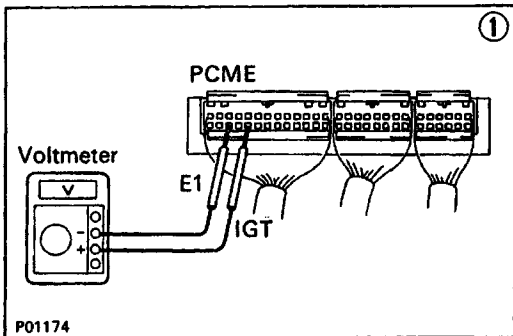
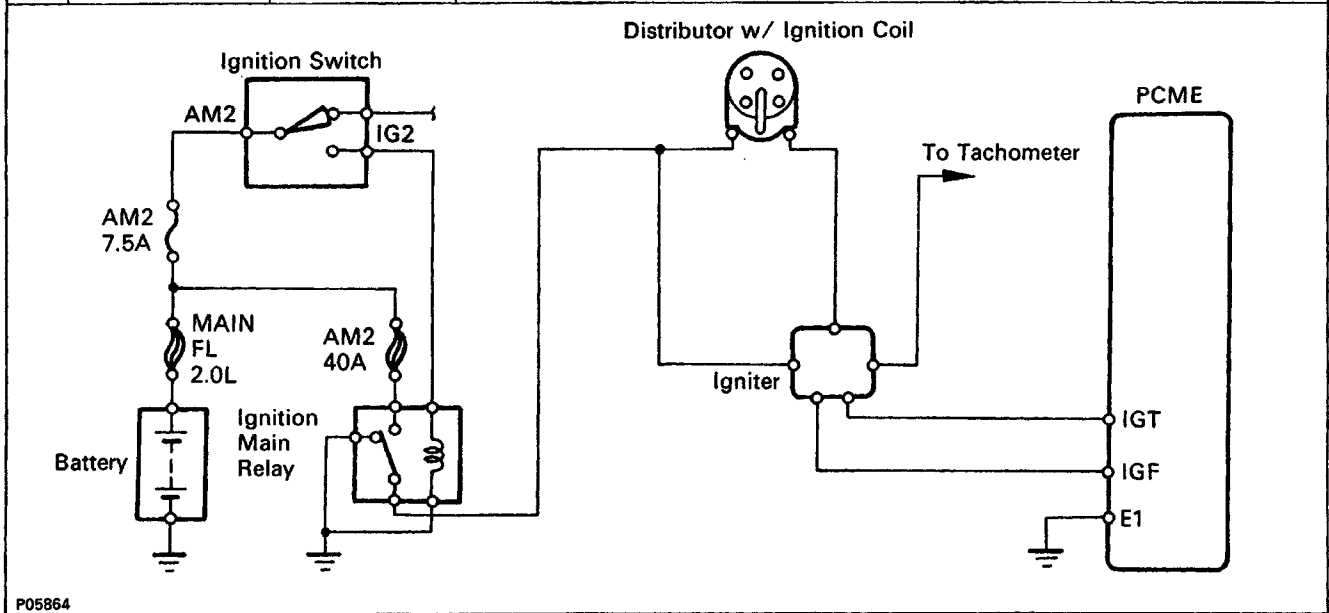

(1) There is no voltage between PCME terminals IGT and E1. (Idling)

(2) Check that there is voltage between PCME terminal IGT and body ground. (Idling)

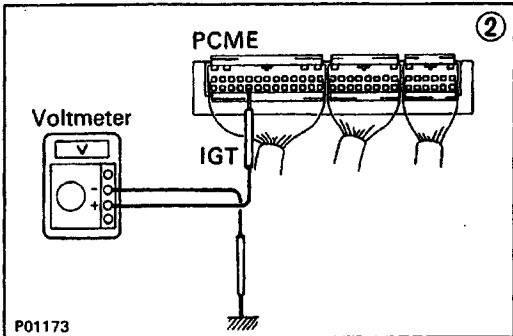

NO → (3) Check wiring between PCME terminal E1 and body ground. BAD → Repair or Replace.

OK → Try another PCME.

Check fuse, H-fuse, fusible link, ignition switch and ignition main relay. BAD → Repair or replace.

OK →

Check distributor. (See IG section) BAD → Repair or replace.

OK →

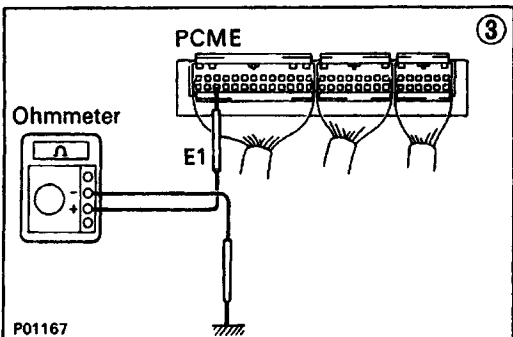

Check wiring between PCME and battery. BAD → Repair or replace.

OK →

Check igniter. (See IG section) BAD → Repair or replace.

No.	Terminals	Trouble	Condition	STD voltage
10	ISCO - E1	No voltage	IG SW ON	9 - 14 V

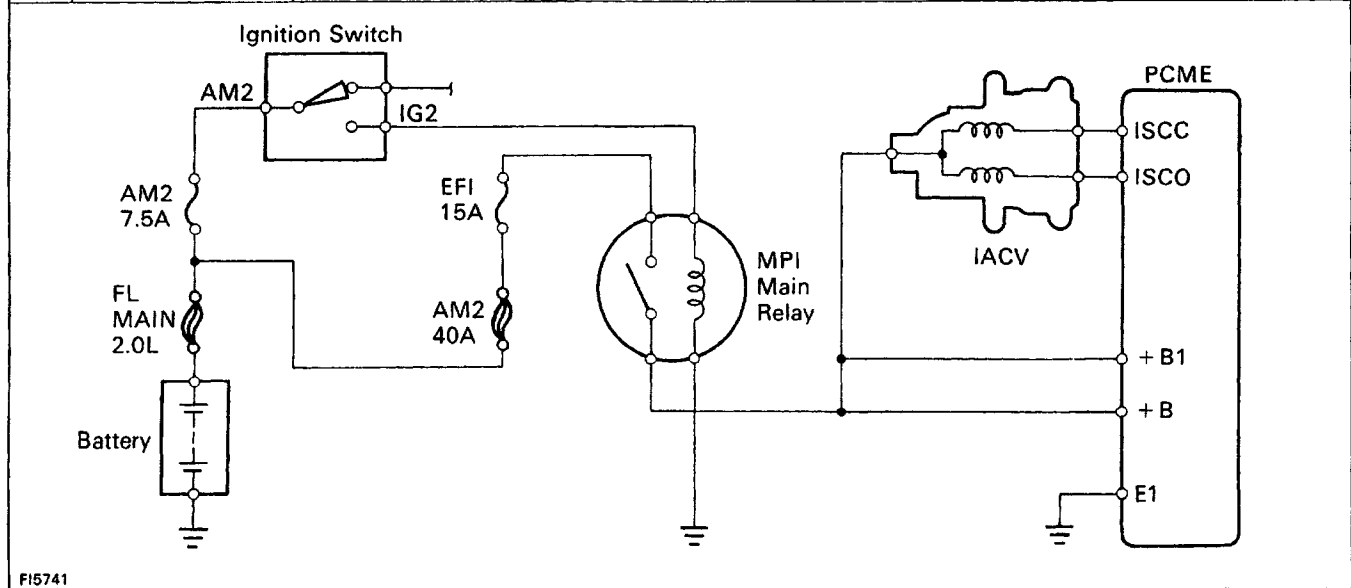

F15741

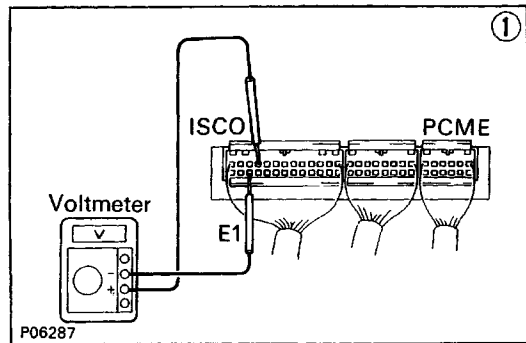

P06287

(1) There is no voltage between PCME terminals ISCO and E1. **(IG SW ON)**

(2) Check that there is voltage between PCME terminal + B or + B1 and body ground. **(IG SW ON)**

OK

NO

Refer to No.1. (See page EG2-220)

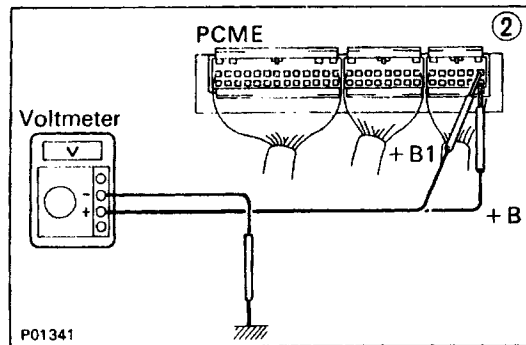

P01341

(3) Check resistance between IACV terminals + B and ISCC or ISCO. **STD resistance: 19.3 - 22.3Ω**

BAD

Replace IACV.

OK

Check wiring between PCME and IACV.

BAD

Repair or replace wiring.

OK

Try another PCME.

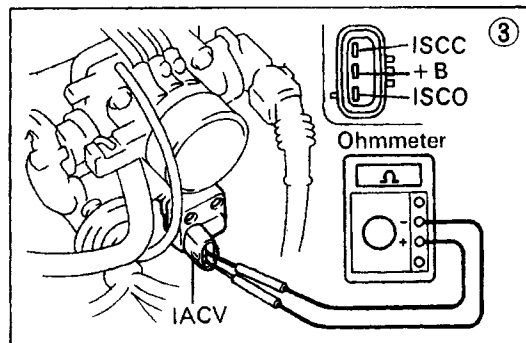

No.	Terminals	Trouble	Condition	STD voltage
11	W - E1	No voltage	No trouble ("CHECK" engine warning light off) and engine running.	9-14V

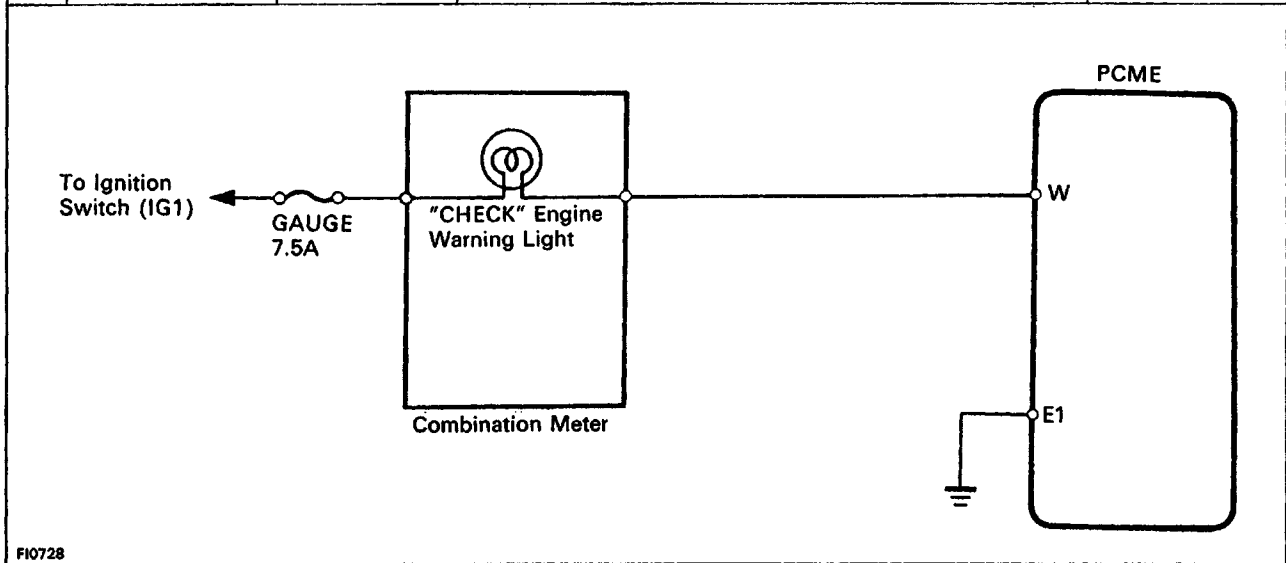

FI0728

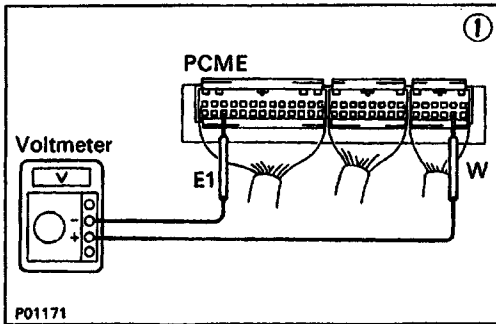

P01171

(1) There is no voltage between PCME terminals W and E1. (Idling)

(2) Check that there is voltage between PCME terminal W and body ground.

NO      OK

(3) Check wiring between PCME terminal E1 and body ground.

OK

Try another PCME.

BAD

Repair or replace.

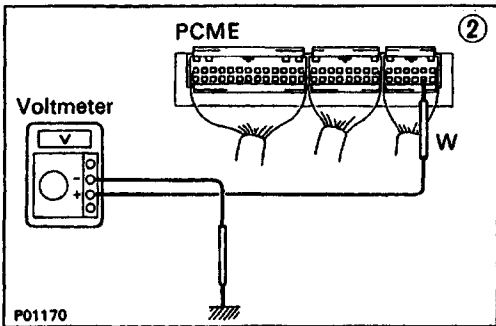

P01170

Check fuse GAUGE (7.5A) and check engine warning light.

OK

BAD

Repair or replace.

Fuse blows again

Check wiring between PCME terminal W and fuse.

BAD

Repair or replace.

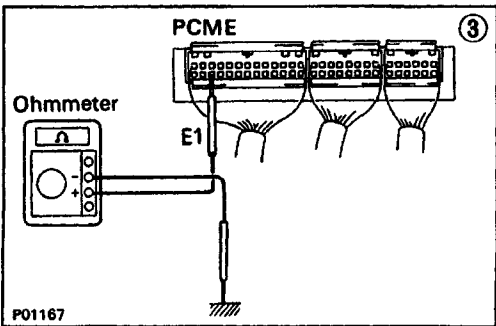

P01167

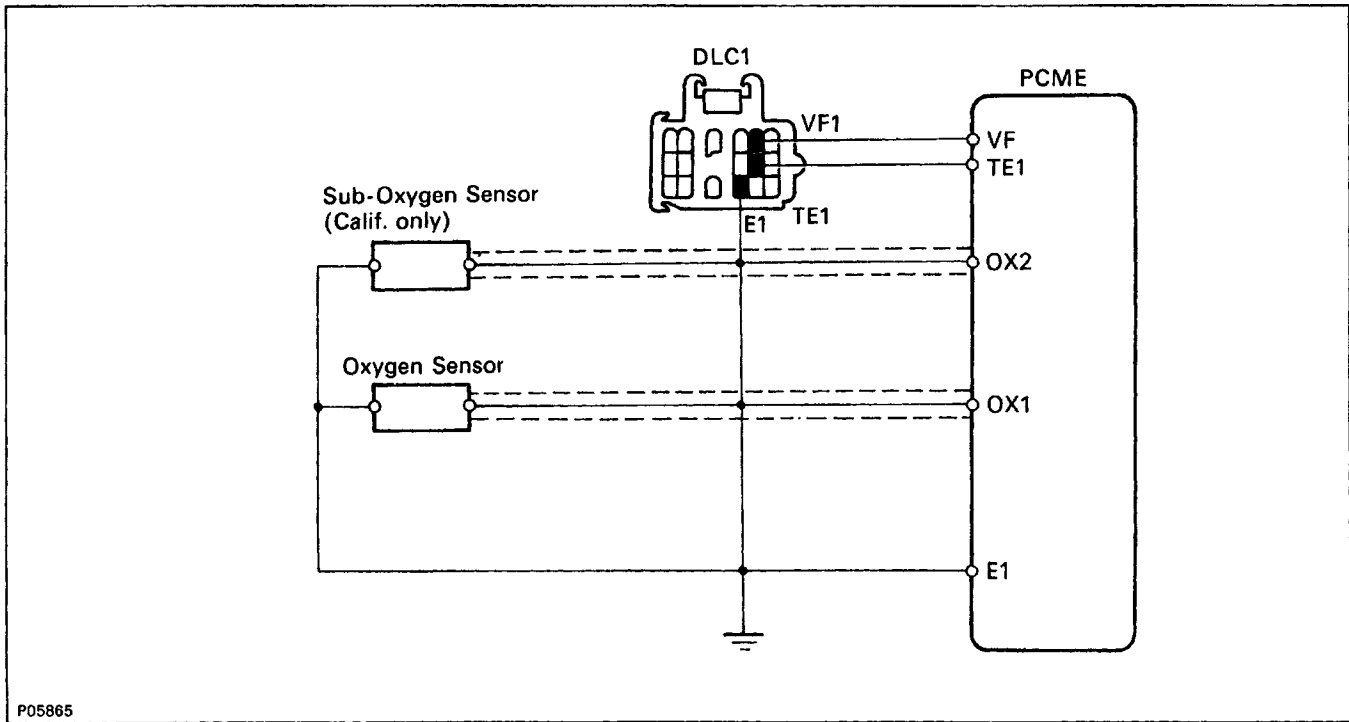

P05865

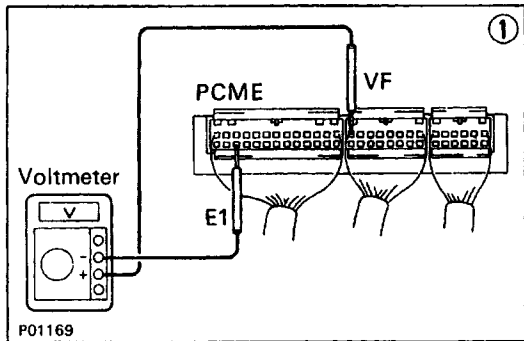

P01169

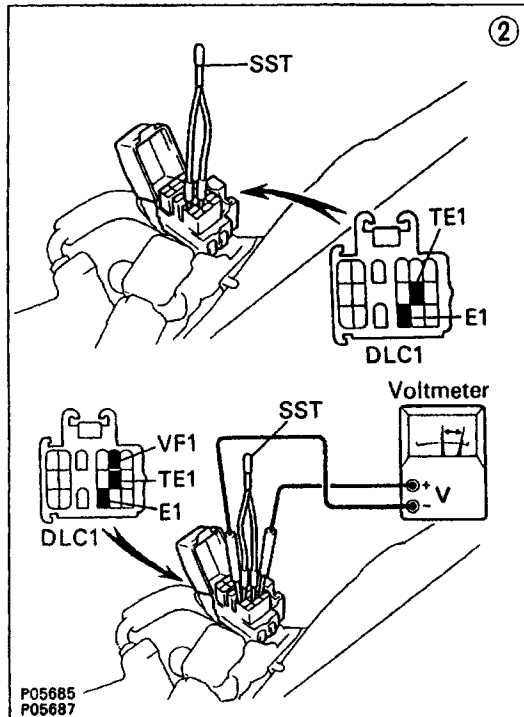

P05685  
P05687

```

    graph TD
      Start["(1) There is no voltage between PCME terminals VF and E1."] --> CheckVF["Check that there is specified between PCME terminal VF and body ground."]
      CheckVF -- NO --> CheckE1["Check wiring between PCME terminal E1 and body ground."]
      CheckVF -- OK --> CheckAirExhaust["Check for suction of air into exhaust system."]
      CheckE1 -- OK --> TryPCME["Try another PCME."]
      CheckE1 -- BAD --> RepairE1["Repair or replace."]
      CheckAirExhaust -- BAD --> RepairAirSuction["Repair air suction."]
      CheckAirExhaust -- OK --> CheckAirIntake["Check for air leak from air intake system."]
      CheckAirIntake -- BAD --> RepairAirLeak["Repair air leak."]
      CheckAirIntake -- OK --> CheckSparkPlugs["Check spark plugs."]
      CheckSparkPlugs -- BAD --> RepairSparkPlugs["Repair or replace."]
      CheckSparkPlugs -- OK --> CheckIgnition["Check distributor w/ ignition coil and ignition system."]
      CheckIgnition -- BAD --> RepairIgnition["Repair or replace."]
      CheckIgnition -- OK --> CheckFuelPressure["Check fuel pressure."]
      CheckFuelPressure -- BAD --> RepairFuelPressure["Repair or replace."]
      CheckFuelPressure -- OK --> CheckInjectors["Check injectors."]
      CheckInjectors -- BAD --> RepairInjectors["Repair or replace."]
      CheckInjectors -- OK --> CheckMAP["Check manifold absolute pressure sensor."]
      CheckMAP -- BAD --> RepairMAP["Repair or replace."]
      CheckMAP -- OK --> CheckOxygenSensors["Check operation of oxygen sensors."]
      CheckOxygenSensors -- OK --> SystemNormal["System normal."]
      CheckOxygenSensors -- BAD --> CheckWiring["Check wiring between oxygen sensors and PCME connectors."]
      CheckWiring -- BAD --> RepairWiring["Repair wiring."]
      CheckWiring -- OK --> RepairOxygenSensors["Repair oxygen sensors."]
  
```



Calif. only

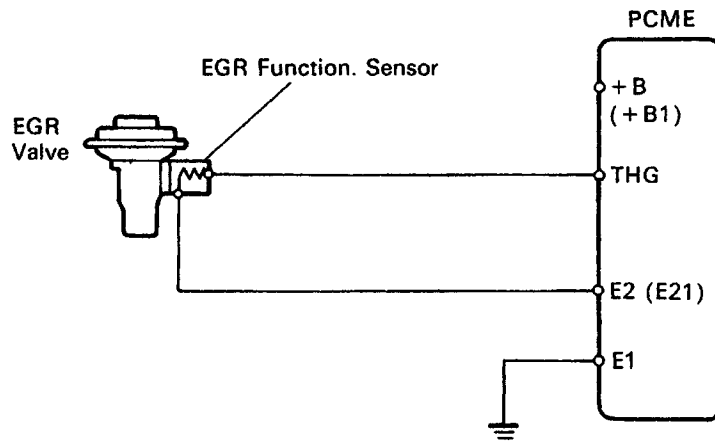

F12680

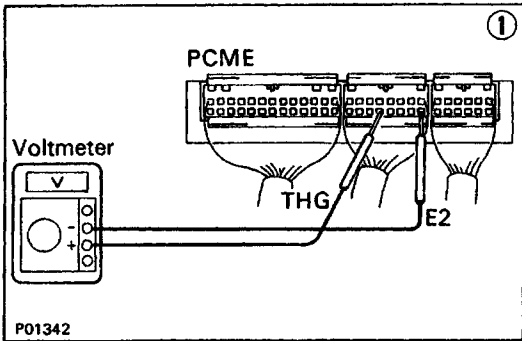

(1) There is no voltage between PCME terminals THG and E2. (IG SW ON)

(2) Check that there is voltage between PCME terminal + B or + B1 and body ground. (IG SW ON)

Refer to No.1 (See page EG2-220)

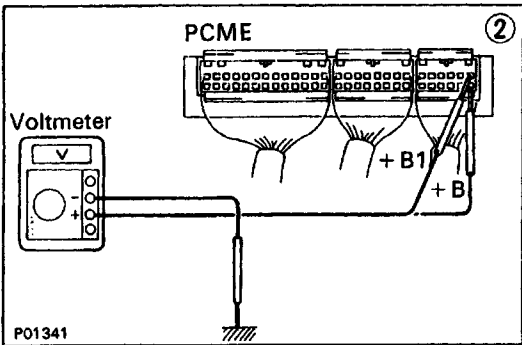

Check wiring between PCME terminal E1 and body ground.

Repair or replace

Check EGR system. (See page EG2-173)

Repair or replace.

(3) Check EGR function sensor. (See page EG2-321)

Replace EGR function sensor.

Check wiring between PCME and EGR function sensor.

Try another PCME.

Repair or replace.

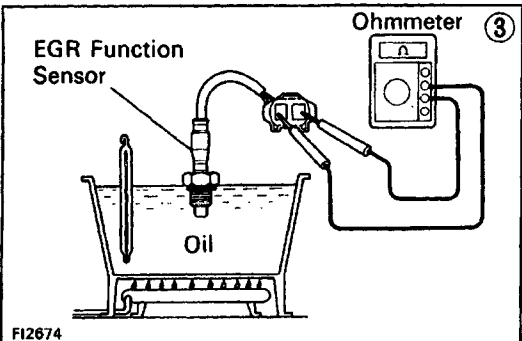

# SYSTEM CHECK PROCEDURE (A/T) PREPARATION

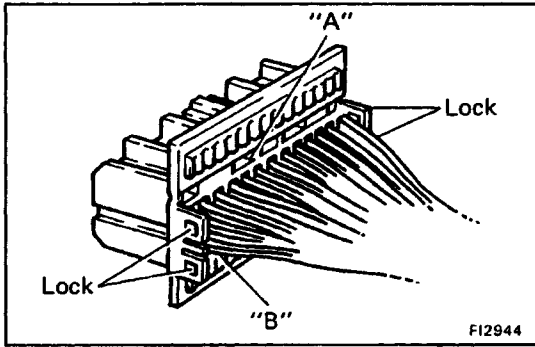

- (a) Disconnect the connectors from the PCME&T.
- (b) Remove the locks as shown in the illustration so that the tester probe(s) can easily come in.

**NOTICE: Pay attention to sections 'A' and 'B' in the illustration which can be easily broken.**

- (e) Reconnect the connectors to the PCME&T.

**HINT:**

- Perform all voltage measurements with the connectors connected.
- Verify that the battery voltage is 11 V or more when the ignition switch is in the "ON" position.

Using a voltmeter with high impedance (10 kΩ/V minimum), measure the voltage at each terminal of the wiring connectors.

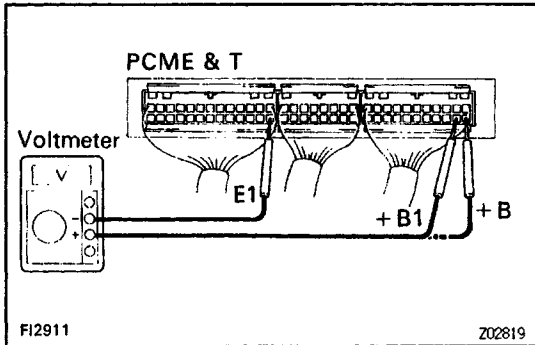

## PCME & T Terminals (A/T)

Symbol	Terminal Name	Symbol	Terminal Name	Symbol	Terminal Name
E01	POWER GROUND	S1	ECT SOLENOID		-
E02	POWER GROUND	S2	ECT SOLENOID	ACT	A/C AMPLIFIER
#10	INJECTOR	SL	ECT SOLENOID	SP1	VSPG
	-	E1	ENGINE GROUND	OD1	OD OFF SWITCH
#20	INJECTOR	VF	DLC1	ACA	A/C AMPLIFIER
	-	E21	SENSOR GROUND		
ISCO	IDLE AIR CONTROL VALVE	TT	DLC1	OD2	OD MAIN SWITCH
EGR	EG R VSV	TE1	DLC1		-
ISCC	IDLE AIR CONTROL VALVE	OX1	OXYGEN SENSOR		
	-	TE2	DLC1		-
FPU	FUEL PRESSURE VSV	*OX2	SUB-OXYGEN SENSOR	W	WARNING LIGHT
	-	KNK	KNOCK SENSOR	PS	PS CONTROL MODULE
ISCV	A/C IDLE-UP VSV	THW	ECTS	B/K	STOP LIGHT SWITCH
IGT	IGNITER	IDL	THROTTLE POSITION SENSOR	PSCT	PS CONTROL MODULE
2	PARK/NEUTRAL SWITCH	THA	INTAKE AIR TEMP.SENSOR	THE	EVAPORATOR TEMP. SENSOR
L	PARK/NEUTRAL SWITCH	VTA	THROTTLE POSITION SENSOR	FC	CIRCUIT OPENING RELAY
NE-	DISTRIBUTOR	PIM	MAP	ELS	TAILLIGHT RELAY DEFOGGER SWITCH
G+	DISTRIBUTOR	*THG	EGR FUNCTION SENSOR	+ B	MPI MAIN RELAY
NE+	DISTRIBUTOR	VC	MAP THROTTLE POSITION SENSOR	BATT	BATTERY
G-	DISTRIBUTOR	E2	SENSOR GROUND	+ B1	MPI MAIN RELAY
IGF	IGNITER	STA	STARTER SWITCH	* Calif. only	
SP2	VSPG	NSW	PARK/NEUTRAL SWITCH		

**PCME & T Terminals**

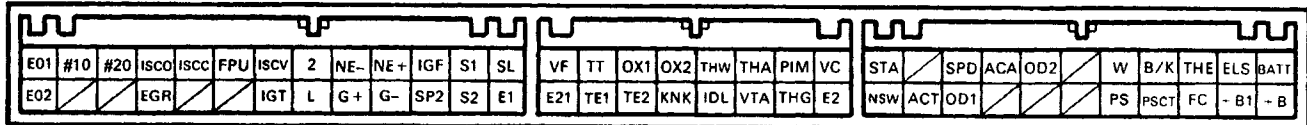

**PCME & T Wiring Connectors Voltage (A/T)**

No.	Terminals	Condition		STD voltage (V)	See page
1	+B +B1 - E1	IG SW ON		9 - 14	<a href="#">EG2-236</a>
2	BATT - E1	—		9 - 14	<a href="#">EG2-237</a>
3	IDL - E2	IG SW ON	Throttle valve open	9 - 14	<a href="#">EG2-238</a>
	VC - E2		—	4.5 - 5.5	
	VTA - E2		Throttle valve fully closed (Throttle opener must be cancelled first)	0.3 - 0.8	
			Throttle valve fully open	3.2 - 4.9	
4	PIM - E2	IG SW ON		3.3 - 3.9	<a href="#">EG2-240</a>
	VC - E2			4.5 - 5.5	
5	#10 E01 #20 E02				9 - 14
6	THA - E2	IG SW ON	Intake air temp. 20°C (68°F)	0.5 - 3.4	<a href="#">EG2-242</a>
7	THW - E2		Coolant temp. 80°C (176°F)	0.2 - 1.0	<a href="#">EG2-243</a>
8	STA - E1	Cranking		6 or more	<a href="#">EG2-244</a>
9	IGT - E1	Idling		Pulse generation	<a href="#">EG2-245</a>
10	ISCO - E1	IG SW ON		9 - 14	<a href="#">EG2-246</a>
11	W - E1	No trouble ("CHECK" engine warning light off) and engine running		9 - 14	<a href="#">EG2-247</a>

**PCME & T Terminals**

E01	#10	#20	ISCO	ISCC	FPU	ISCV	2	NE-	NE+	IGF	S1	SL	VF	TT	OX1	OX2	THW	THA	PIM	VC	STA	SPD	ACA	OD2	W	B/K	THE	ELS	BATT
E02			EGR			IGT	L	G+	G-	SP2	S2	E1	E21	TE1	TE2	KNK	IDL	VTA	THG	E2	NSW	ACT	OD1		PS	PSCT	FC	-B1	+B

No.	Terminals	Trouble	Condition	STD voltage
1	+B +B1 - E1	No voltage	IG SW ON	9 - 14 V

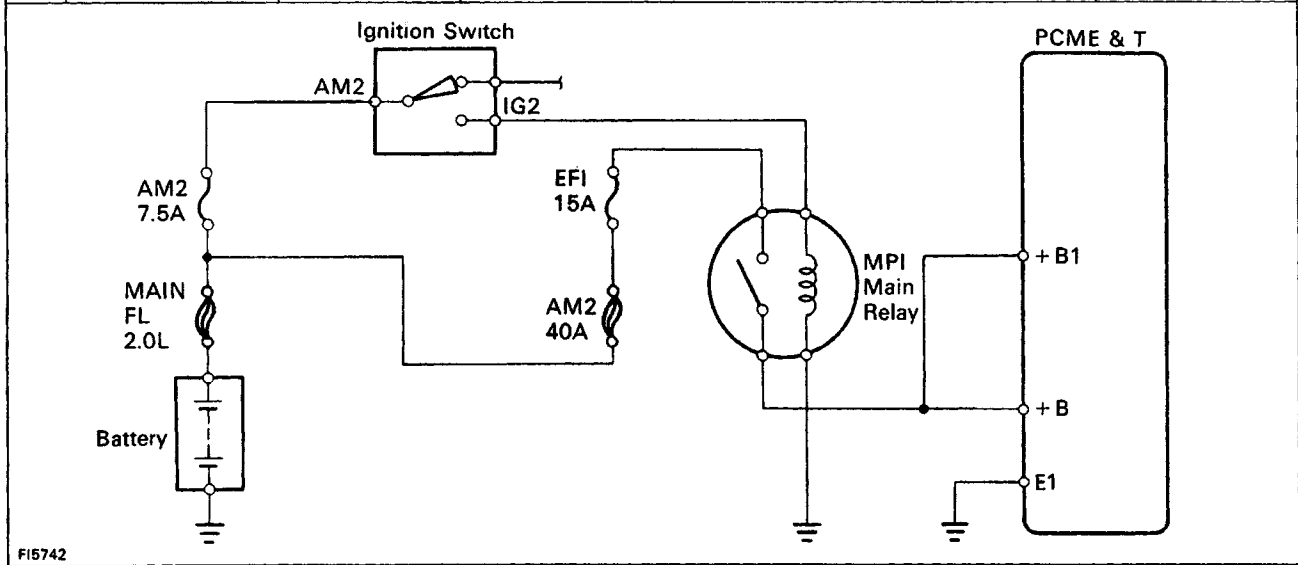

FI5742

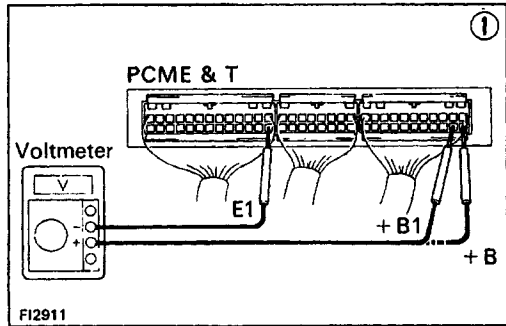

FI2911

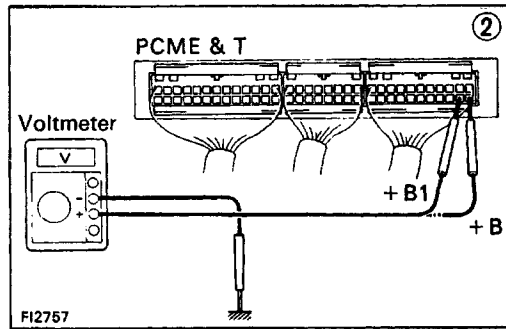

FI2757

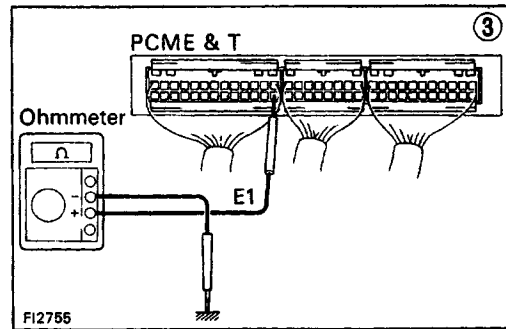

FI2755

(1) There is no voltage between PCME & T terminals +B or +B1 and E1. (IG SW ON)

(2) Check that there is voltage between PCME & T terminal + B or +B1 and body ground. (IG SW ON)

NO OK

(3) Check wiring between PCME & T terminal E1 and body ground.

OK BAD

Try another PCME & T.

Repair or replace.

Check fuses, H-fuse, fusible link and ignition switch.

BAD

Repair or replace.

OK

Check MPI main relay. (See page EG2-302)

BAD

Replace.

OK

Check wiring between MPI main relay and battery.

BAD

Repair or replace.

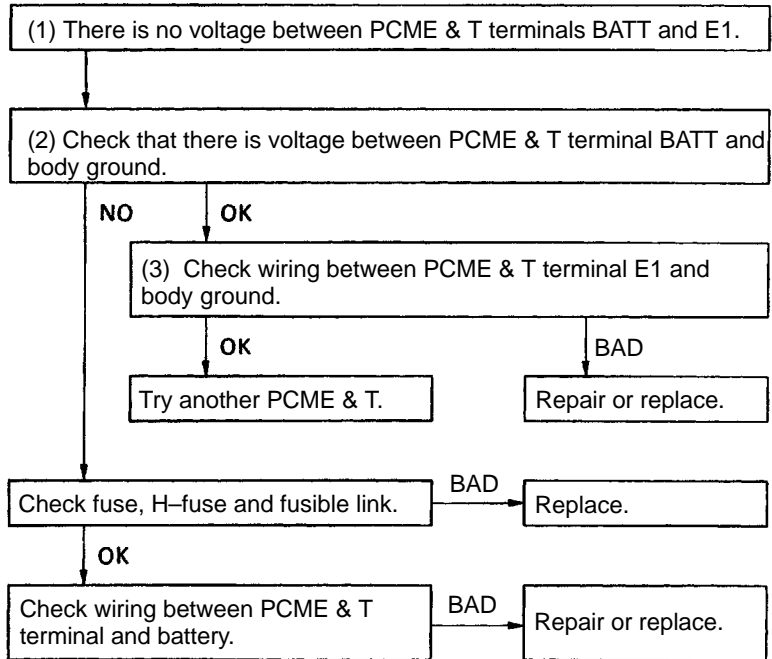
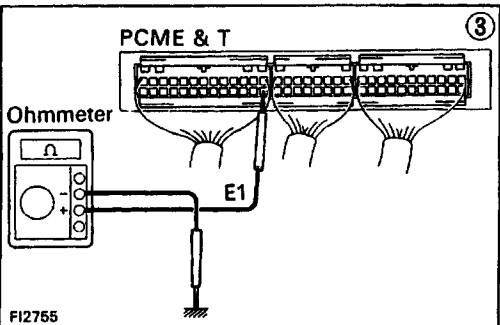
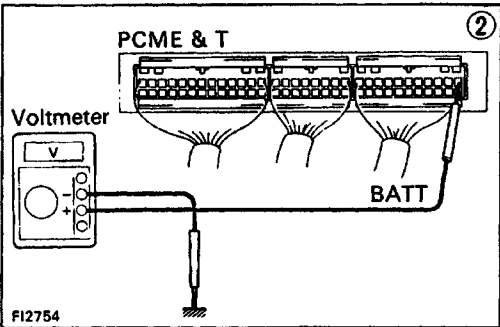
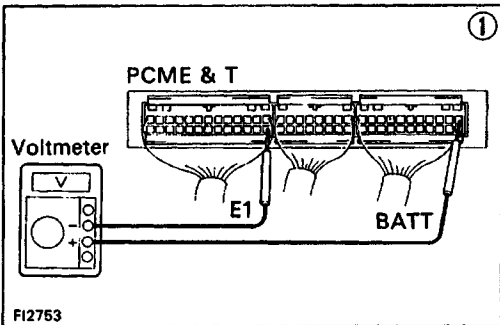
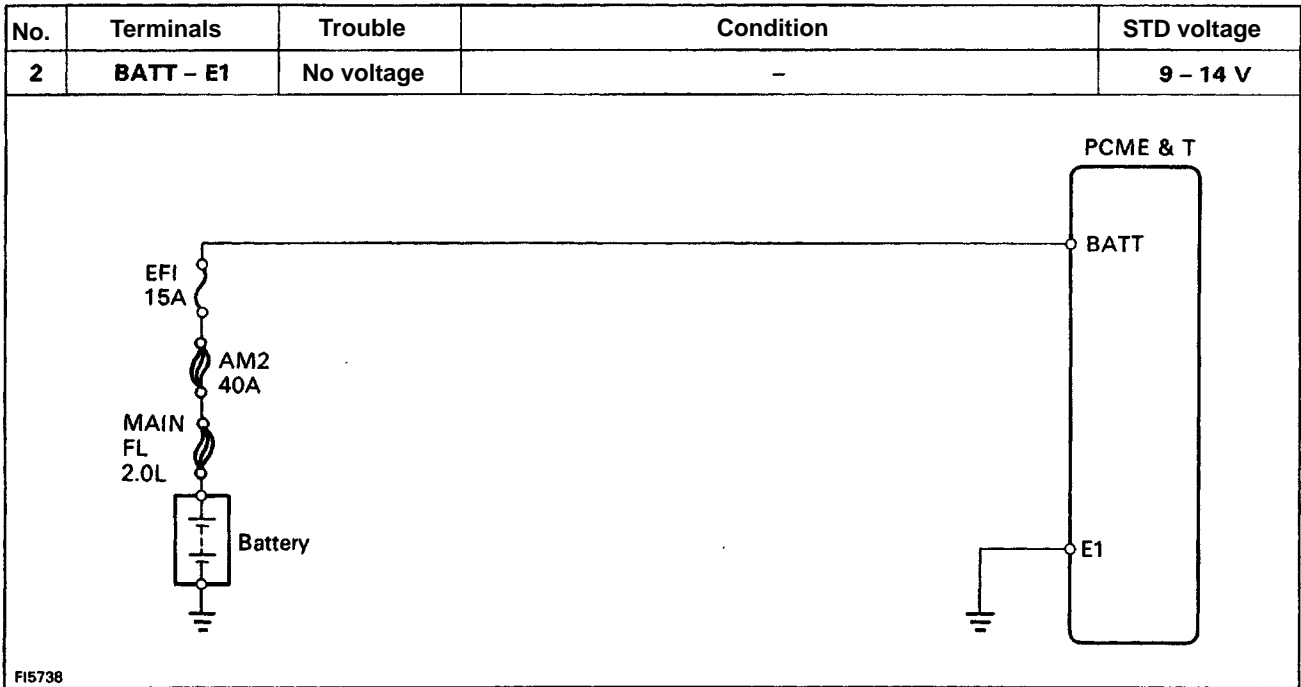

No.	Terminals	Trouble	Condition	STD voltage	
3	IDL - E2	No voltage	IG SW ON	Throttle valve open	9 - 14 V
	VC - E2			-	4.5 - 5.5 V
	VTA - E2			Throttle valve fully closed Throttle opener must be . (cancelled first)	0.3 - 0.8 V
				Throttle valve fully open	3.2 - 4.9 V

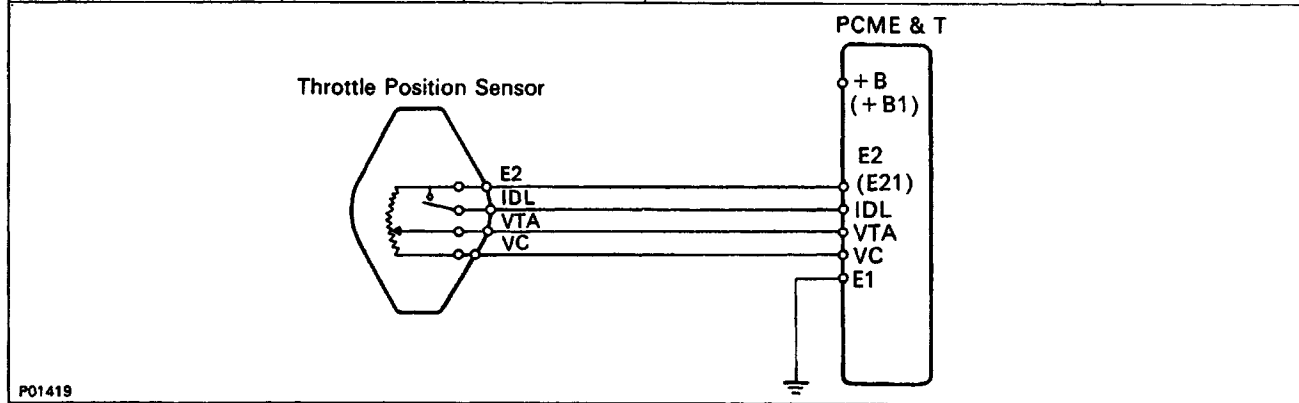

P01419

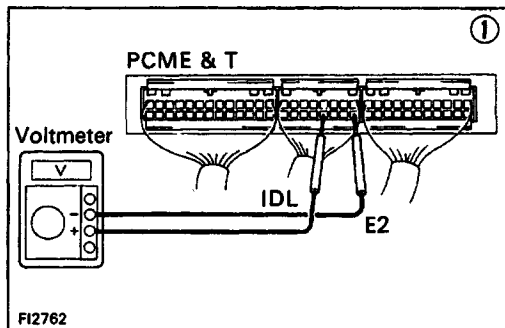

FI2762

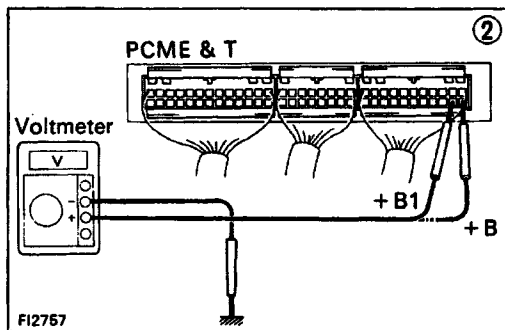

FI2757

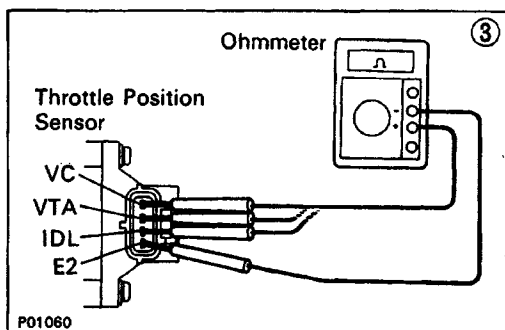

P01060

• IDL- E2

```

    graph TD
      A["(1) There is no voltage between PCME & T terminals IDL and E2.  
(IG SW ON) (Throttle valve open)"] --> B["(2) Check that there is voltage between PCME & T terminal + B (+B1)  
and body ground. (IG SW ON)"]
      B -- NO --> C["Check wiring between PCME & T terminal E1 and body  
ground."]
      B -- OK --> D["Refer to No.1.  
(See page EG2-236)"]
      C -- OK --> E["Try another PCME & T."]
      C -- BAD --> F["Repair or replace."]
      D -- BAD --> F
      D -- OK --> G["(3) Check throttle position sensor.  
(See page EG2-288)"]
      G -- BAD --> H["Repair or replace  
throttle position sensor."]
      G -- OK --> I["Check wiring between PCME & T and  
throttle position sensor."]
      I -- OK --> J["Try another PCME & T."]
      I -- BAD --> F
  
```

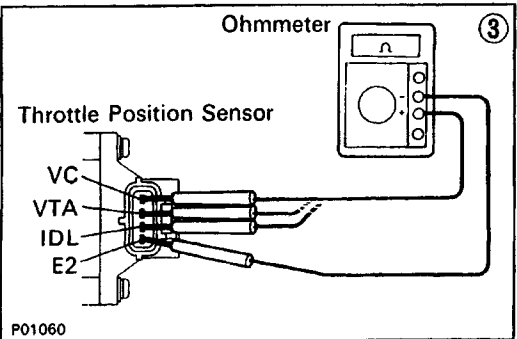
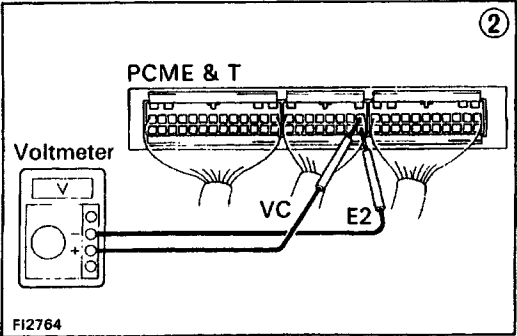
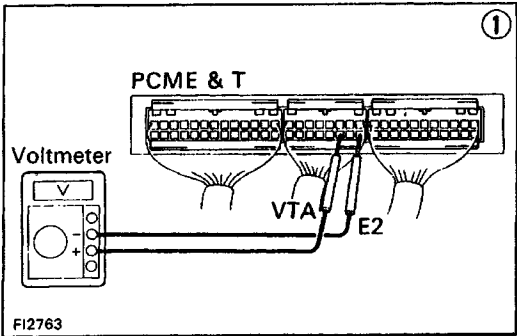
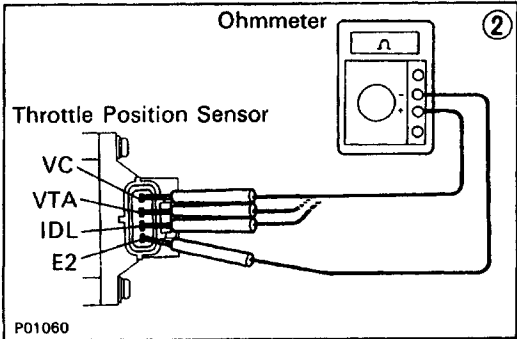
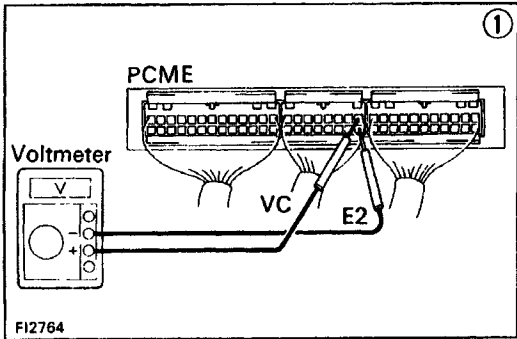

• VC-E2

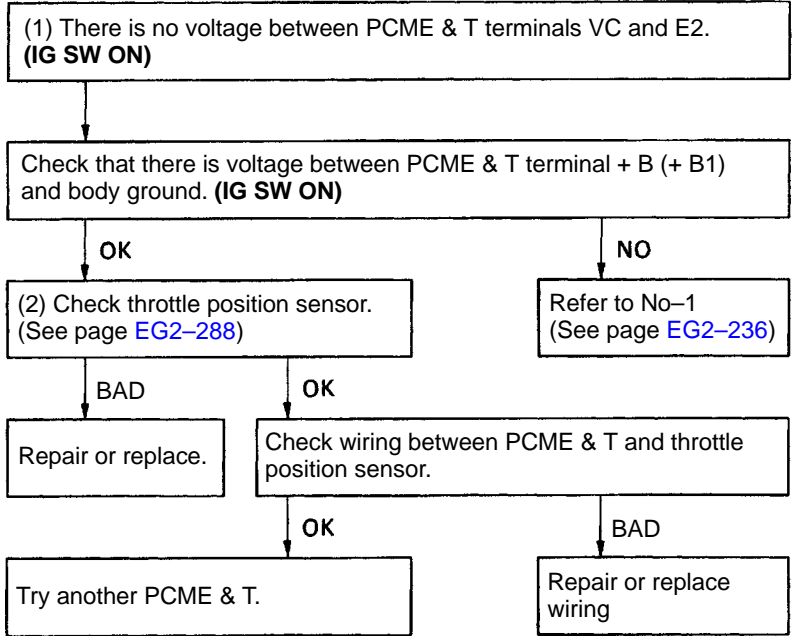

• VTA - E2

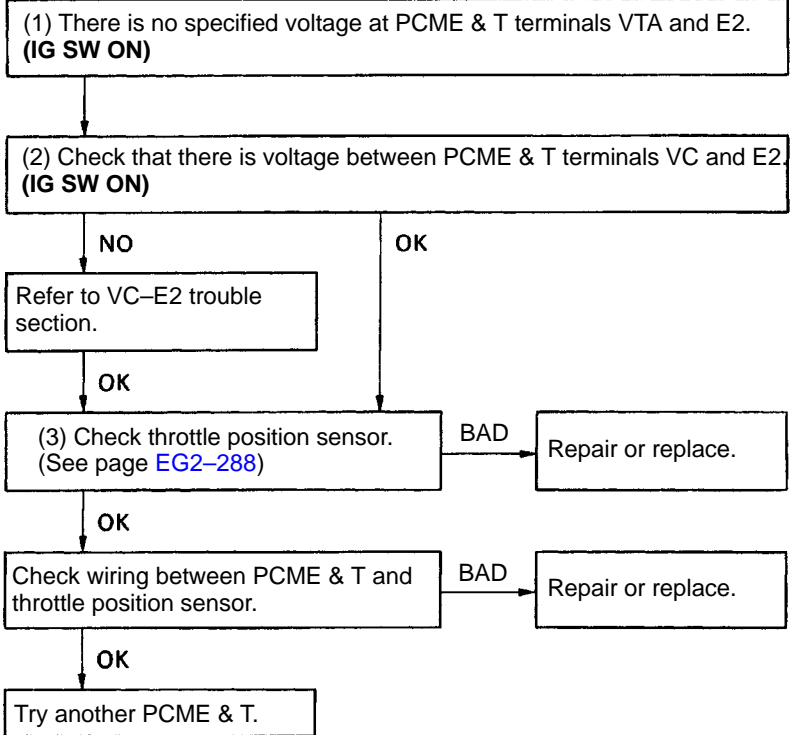

No.	Terminals	Trouble	Condition	STD voltage
4	PIM - E2	No voltage	IG SW ON	3.3 - 3.9 V
	VC - E2			4.5 - 5.5 V

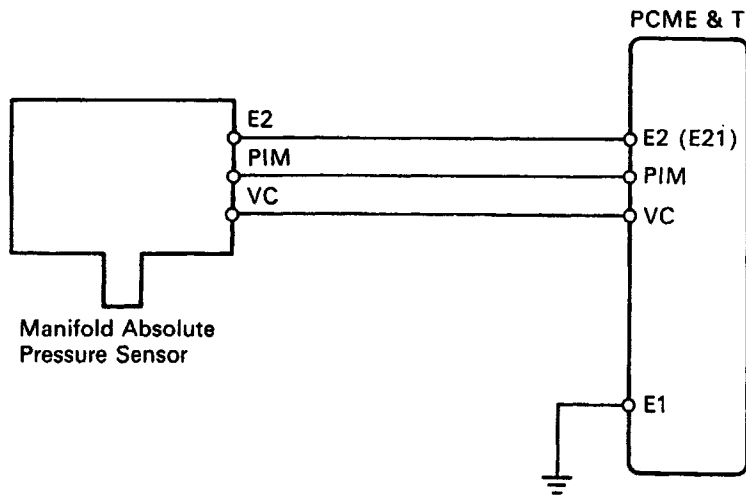

FI1226

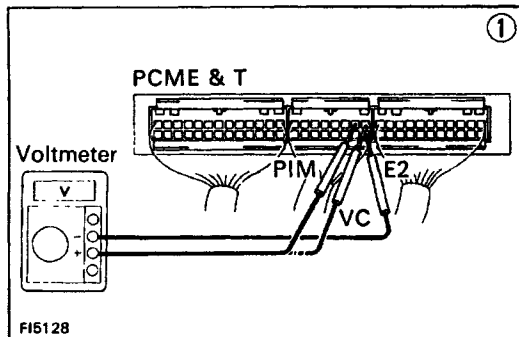

FI6128

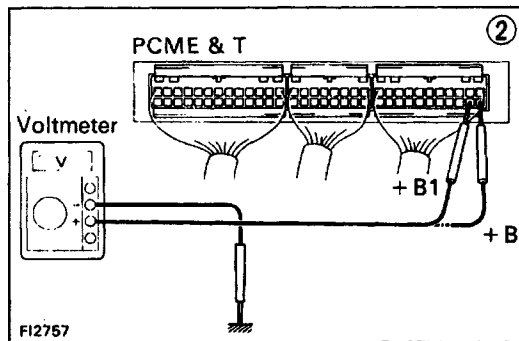

FI2757

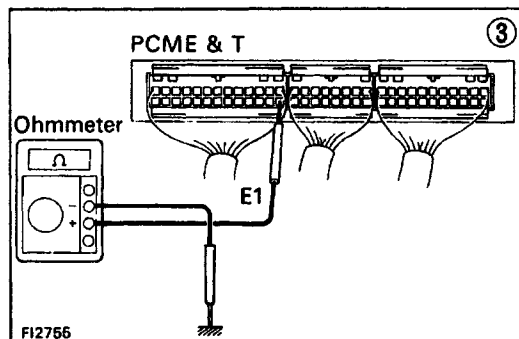

FI2756

(1) There is no voltage between PCME & T terminals PIM or VC and E2. (IG SW ON)

(2) Check that there is voltage between PCME & T terminal + B (+ B1) and body ground. (IG SW ON)

OK

NO

Refer to No.1  
(See page EG2-236)

(3) Check wiring between PCME & T terminal E1 and body ground.

OK

BAD

Check manifold absolute pressure  
(See page EG2-319)

Repair or replace.

BAD

Replace manifold  
absolute pressure  
sensor.

OK

Check wiring between PCME & T and  
manifold absolute pressure sensor.

OK

BAD

Try another PCME & T.

Repair or replace.



No.	Terminals	Trouble	Condition	STD voltage
5	#10 - E01 #20 - E02	No voltage	IG SW ON	9 - 14 V

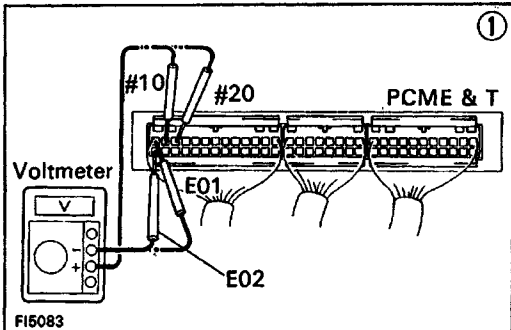
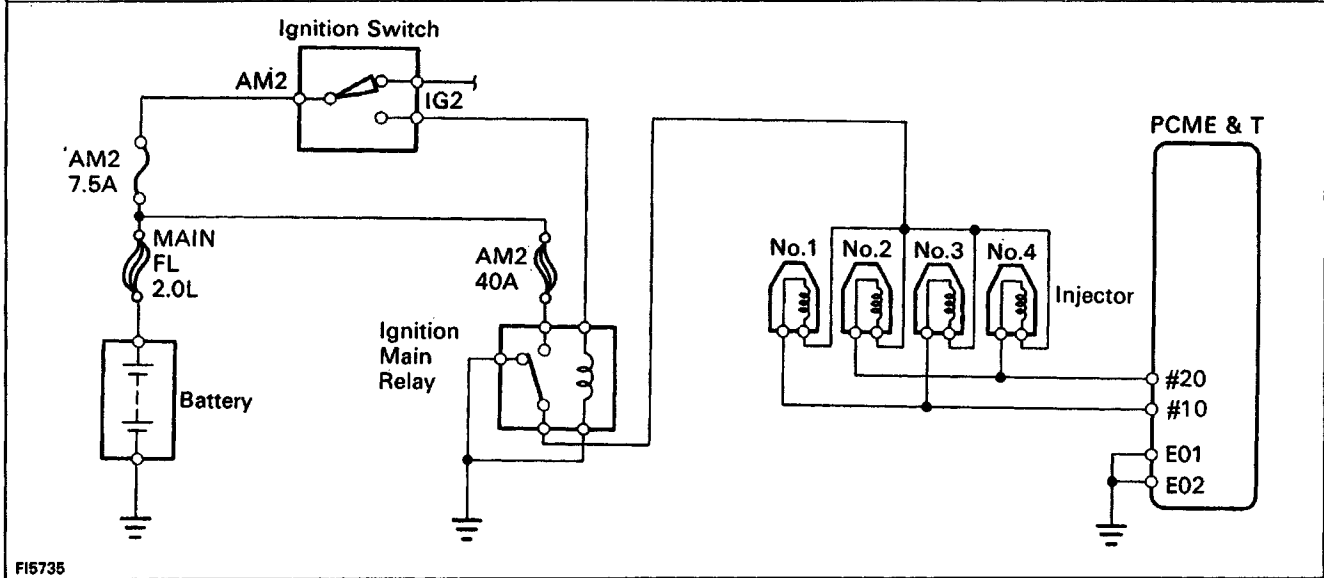

(1) There is no voltage between PCME & T terminals #10 and/or #20 and E01 and/or E02. (IG SW ON)

(2) Check that there is voltage between PCME & T terminal #10 and/or #20 and body ground.

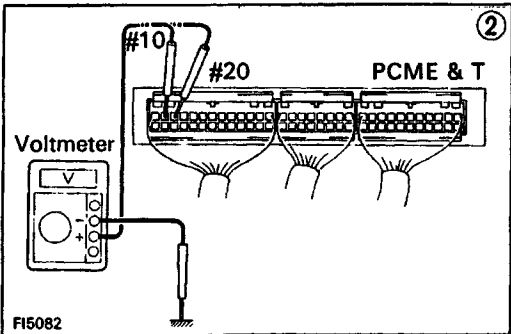
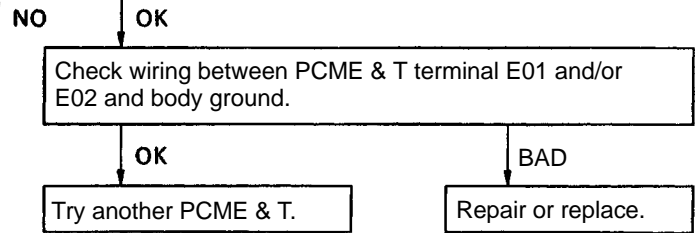

Check fuse, H-fuse, fusible link and ignition switch and ignition main relay. (BAD) Repair or replace.

(3) Check resistance of each injector. STD resistance: Approx. 13.8Ω

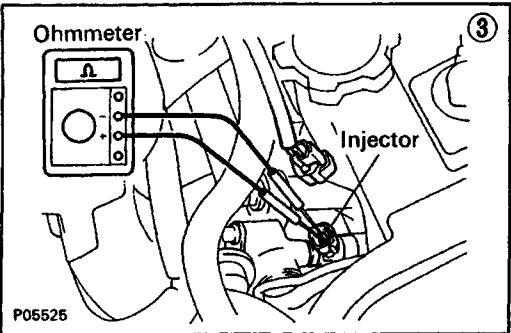

Check wiring between PCME & T terminal No.10 and/or No.20 and battery. (BAD) Repair or replace.

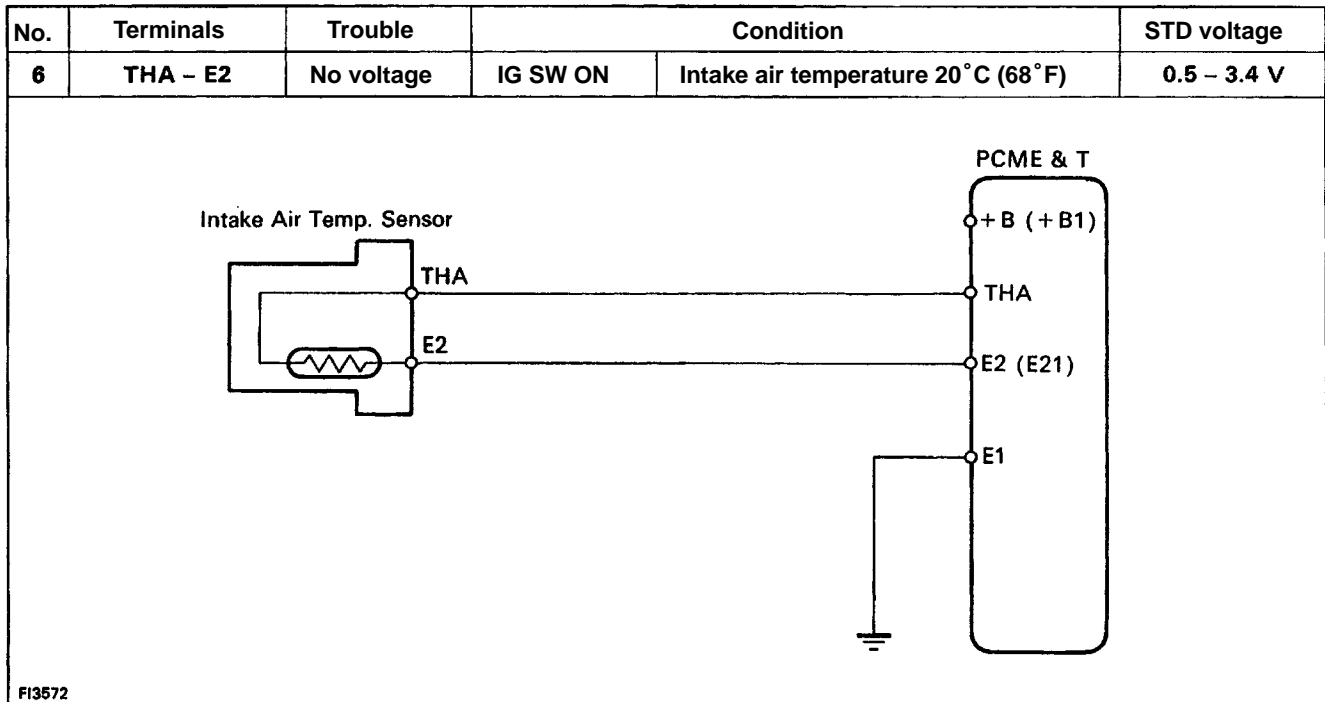

FI3572

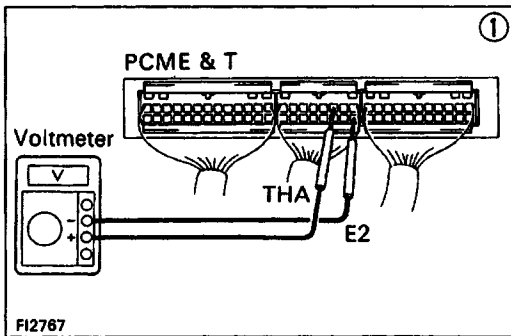

FI2767

(1) There is no voltage between PCME & T terminals THA and E2. (IG SW ON)

(2) Check that there is voltage between PCME & T terminal + B or +B and body ground. (IG SW ON)

OK

NO

Refer to No.1 (See page EG2-236)

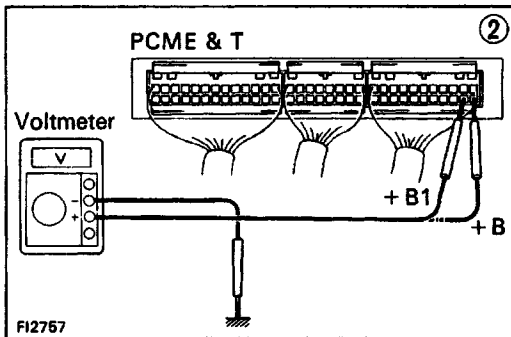

FI2767

Check wiring between PCME & T terminal E1 and body ground.

OK

BAD

(3) Check intake air temp. sensor. (See page EG2-306)

Repair or replace.

BAD

OK

Replace intake air temp. sensor.

Check wiring between PCME & T and air temp. sensor.

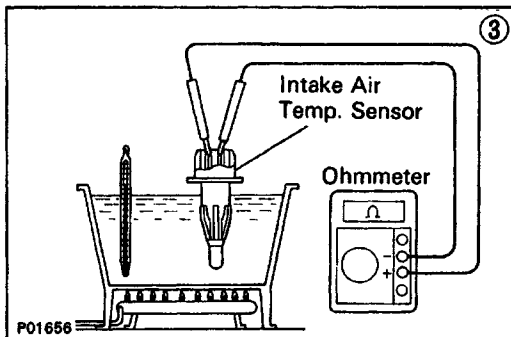

P01656

Try another PCME & T.

BAD

Repair or replace.

No.	Terminals	Trouble	Condition		STD voltage
7	THW - E2	No voltage	IG SW ON	Coolant temperature 80°C (176°F)	0.2 - 1.0 V

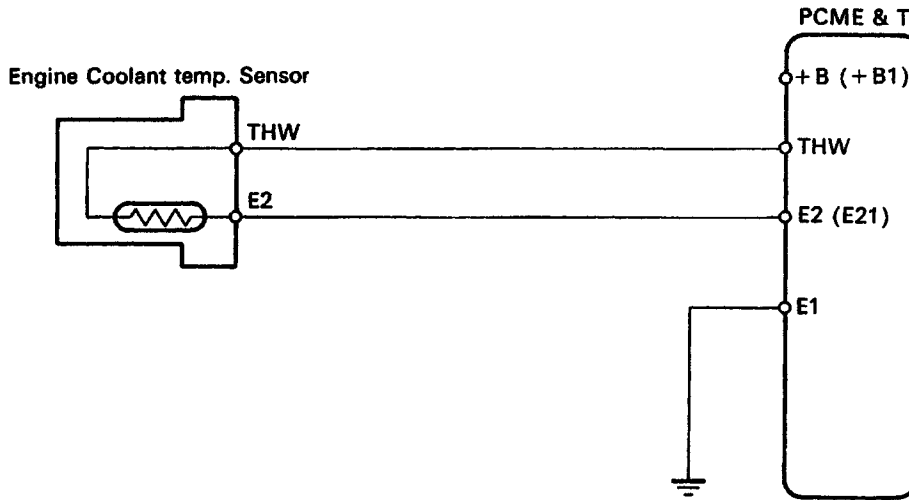

FI3572

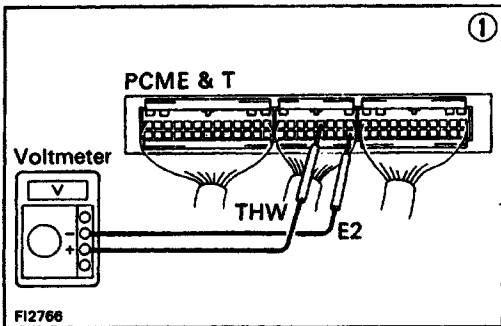

FI2766

(1) There is no voltage between PCME & T terminals THW and E2. (IG SW ON)

(2) Check that there is voltage between PCME & T terminal +B or +B and body ground. (IG SW ON)

OK → Check wiring between PCME & T terminal E1 and body ground.  
 NO → Refer to No.1 (See page EG2-236)

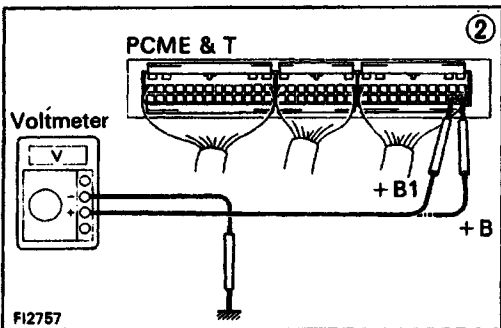

FI2757

Check wiring between PCME & T terminal E1 and body ground.

OK → (3) Check engine coolant temp. sensor (See page EG2-305)  
 BAD → Repair or replace.

BAD → Replace engine coolant temp. sensor.  
 OK → Check wiring between PCME & T and engine coolant temp. sensor.

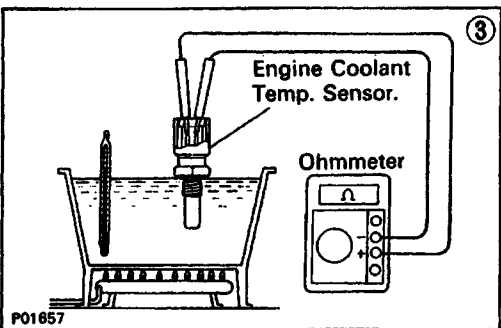

FO1857

OK → Try another PCME & T.  
 BAD → Repair or replace.

No.	Terminals	Trouble	Condition	STD voltage
8	STA - E1	No voltage	Cranking	6 V or more

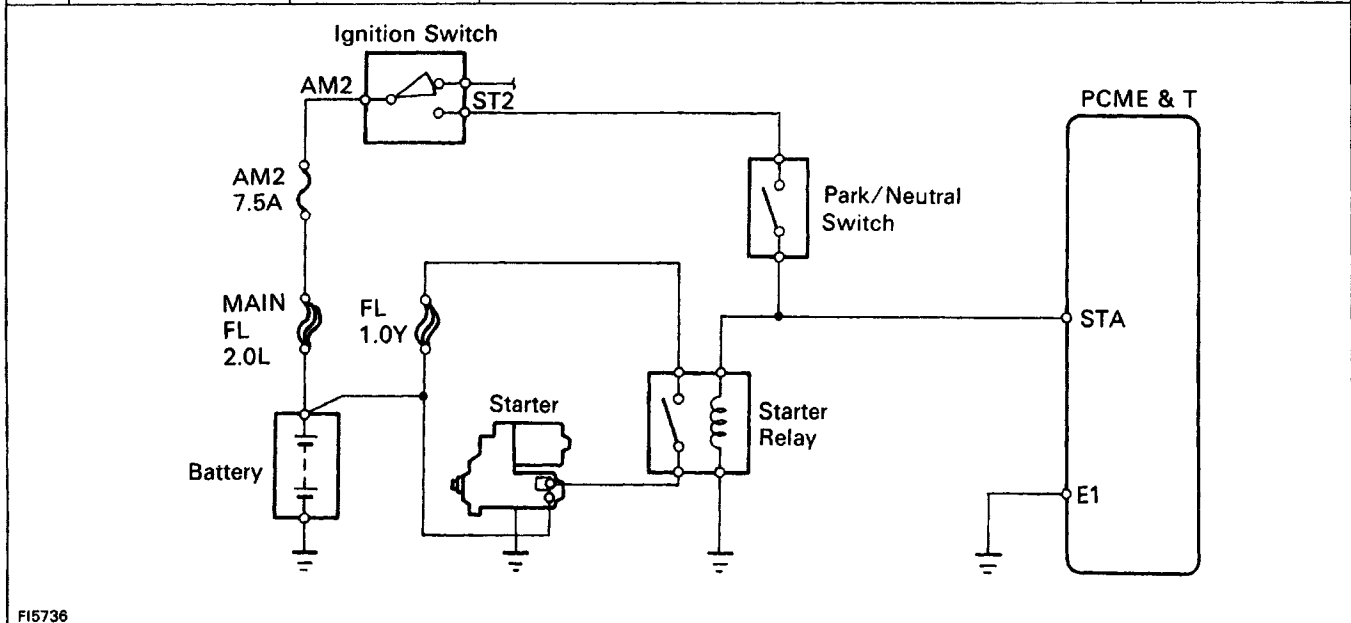

FI5736

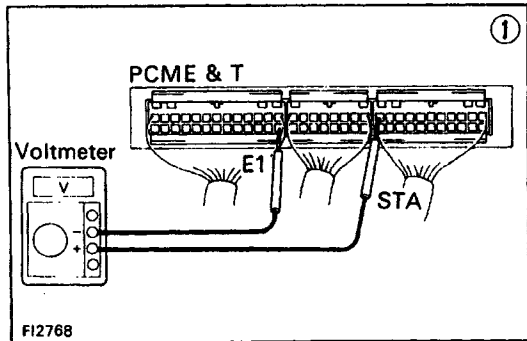

FI2768

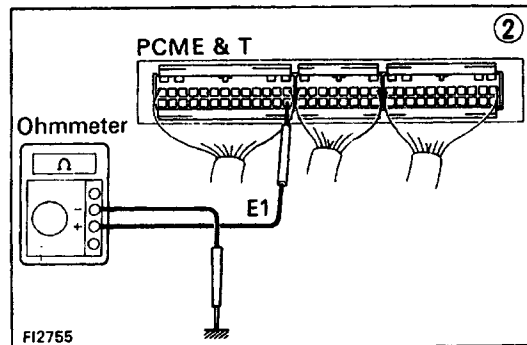

FI2755

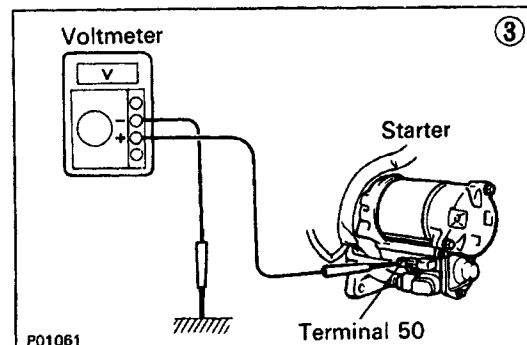

P01061

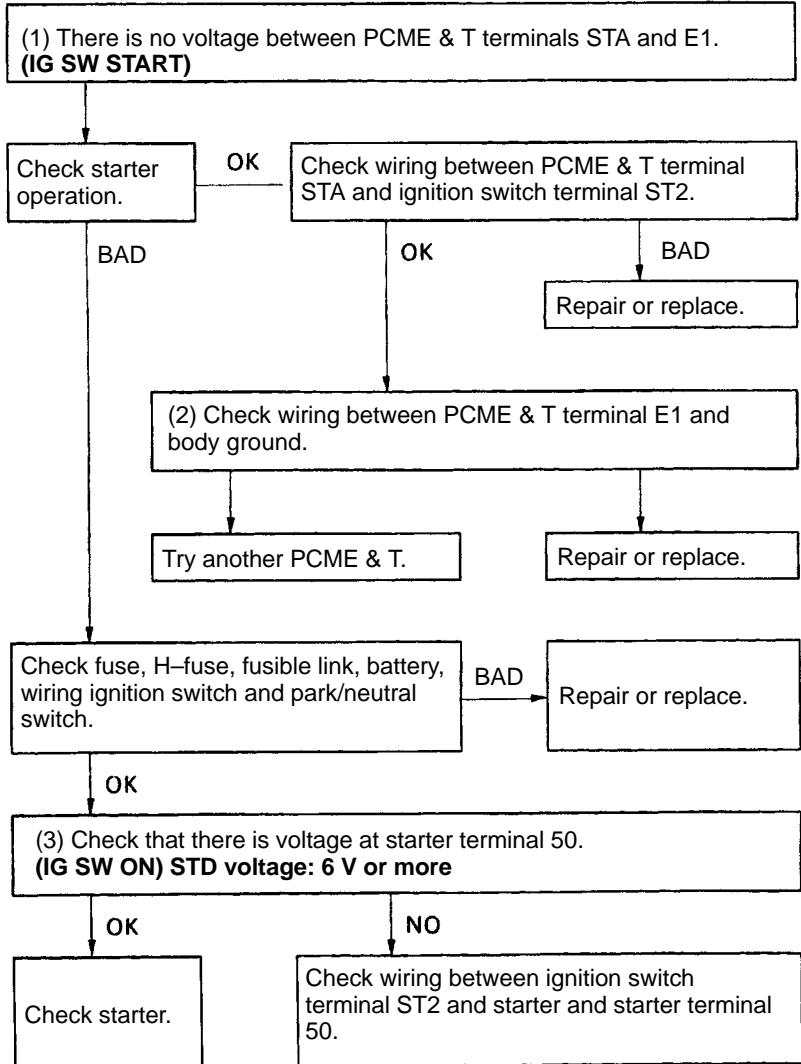

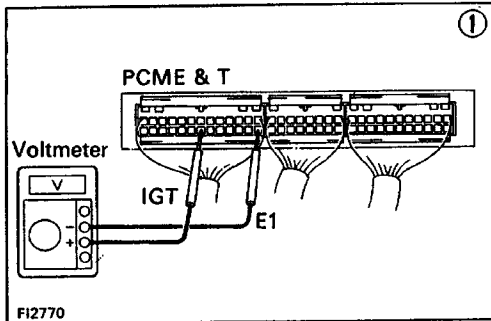
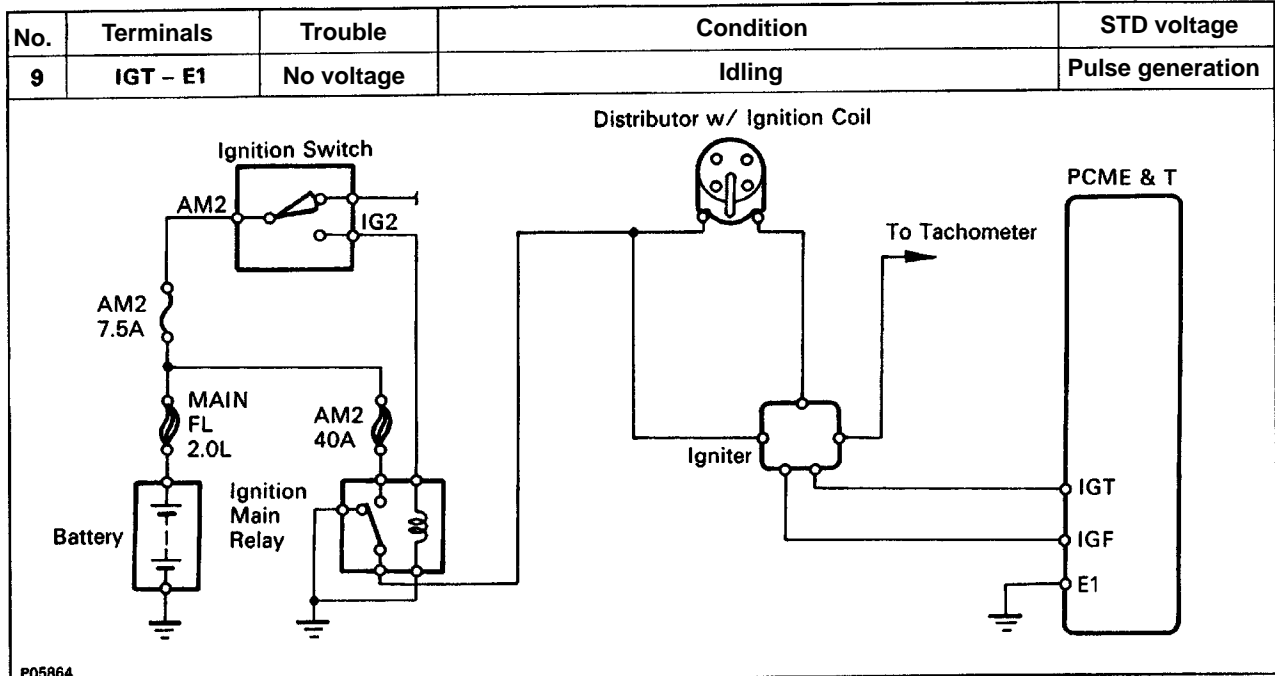

(1) There is no voltage between PCME & T terminals IGT and E1. (**Idling**)

(2) Check that there is voltage between PCME & T terminal IGT and body ground. (**Idling**)

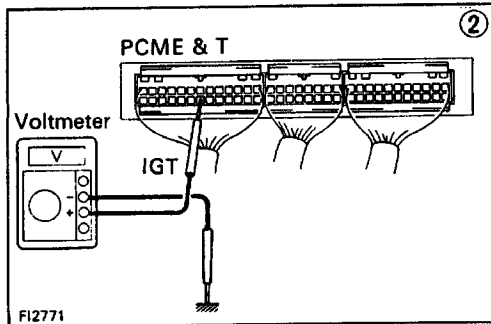

NO

OK

(3) Check wiring between PCME & T terminal E1 and body ground. **BAD** → Repair or Replace.

OK

Try another PCME & T.

Check fuse, H-fuse, fusible link, ignition switch and ignition main relay. **BAD** → Repair or replace.

OK

Check distributor. (See IG section) **BAD** → Repair or replace.

OK

Check wiring between PCME & T and battery. **BAD** → Repair or replace.

OK

Check igniter. (See IG section) **BAD** → Repair or replace.

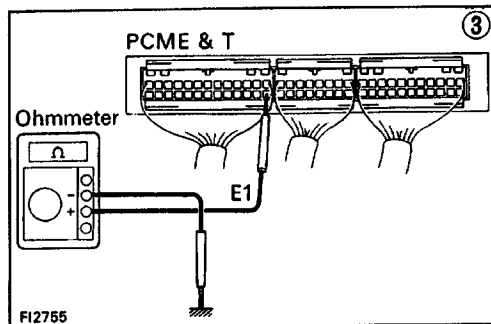

No.	Terminals	Trouble	Condition	STD voltage
10	ISCO - E1	No voltage	IG SW ON	9 - 14 V

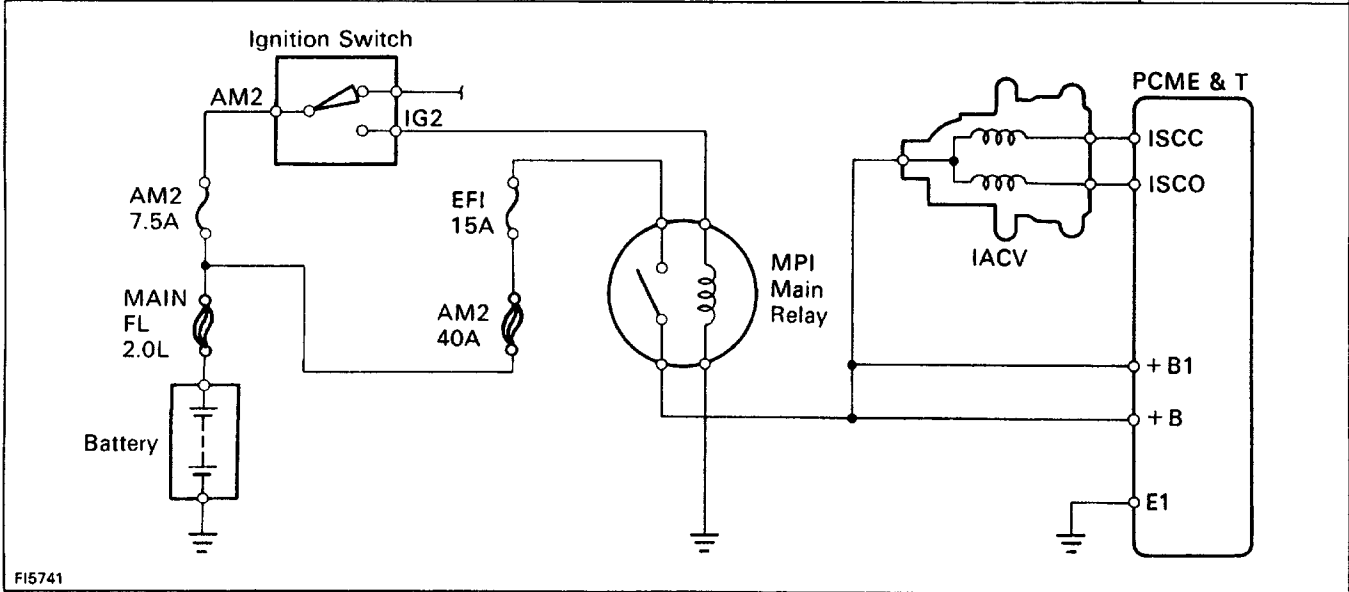

FI5741

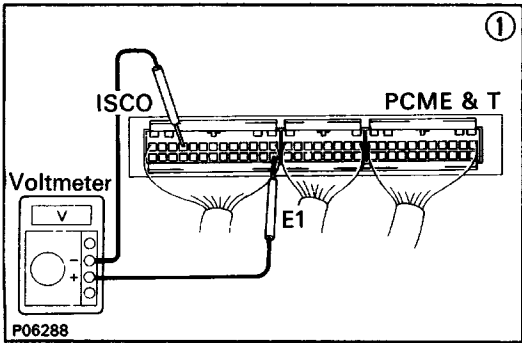

P06288

(1) There is no voltage between PCME & T terminals ISCO and E1. (IG SW ON)

(2) Check that there is voltage between PCME & T terminal +B or +B1 and body ground. (IG SW ON)

OK

NO

Refer to No.1. (See page EG2-236)

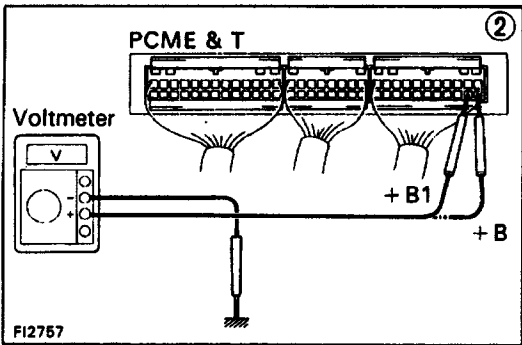

FI2757

(3) Check resistance between IACV terminals +B and ISCC or ISCO. STD resistance: 19.3 - 22.3Ω

BAD

Replace IACV.

OK

Check wiring between PCME & T and IACV.

BAD

Repair or replace wiring.

OK

Try another PCME & T.

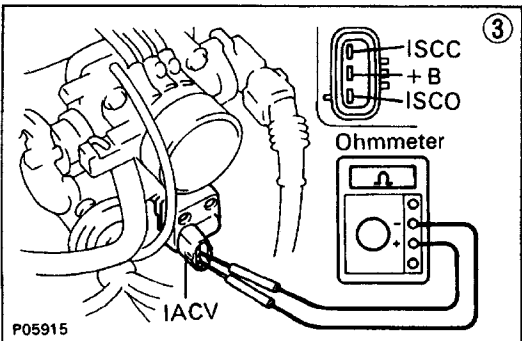

P05915

No.	Terminals	Trouble	Condition	STD voltage
11	W - E1	No voltage	No trouble ("CHECK" engine warning light off) and engine running.	9 - 14 V

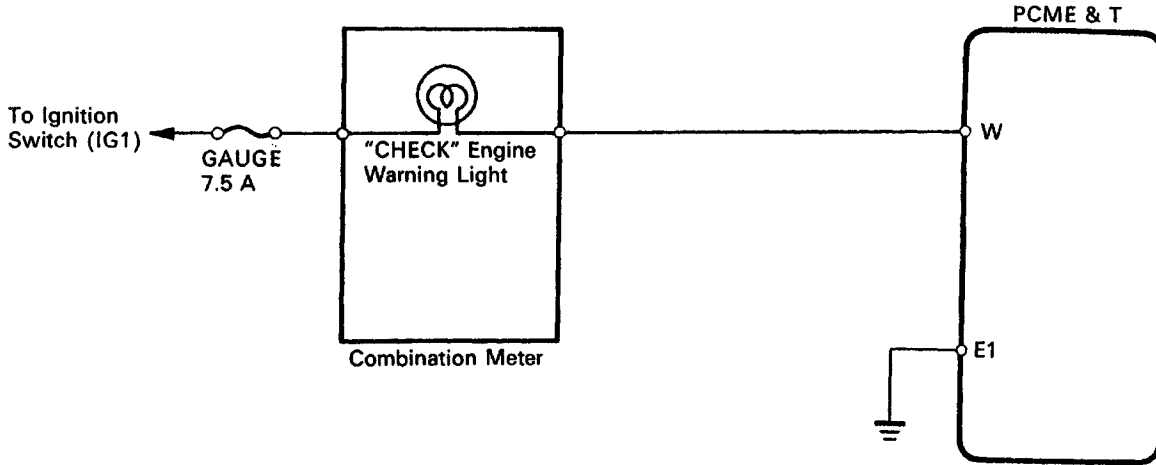

FI0728

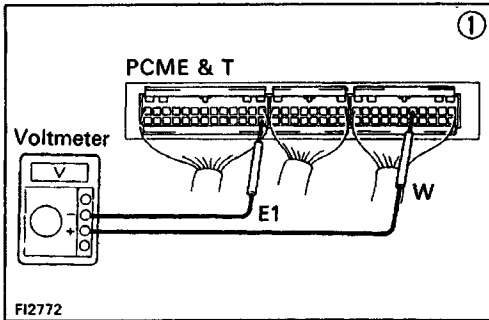

FI2772

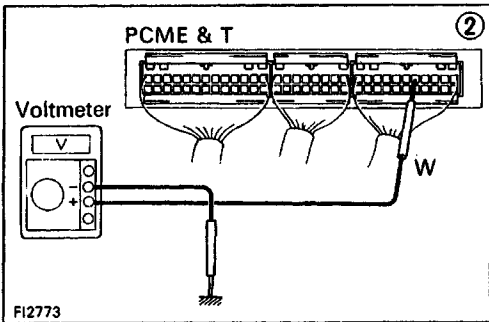

FI2773

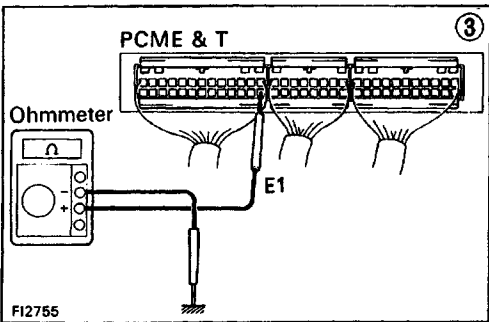

FI2755

```

    graph TD
      A["(1) There is no voltage between PCME & T terminals W and E1. (Idling)"] --> B["(2) Check that there is voltage between PCME & T terminal W and body ground."]
      B -- NO --> C["Check GAUGE fuse (7.5 A) and check engine warning light."]
      B -- OK --> D["(3) Check wiring between PCME & T terminal E1 and body ground."]
      D -- OK --> E["Try another PCME & T."]
      D -- BAD --> F["Repair or replace."]
      C -- OK --> G["Check wiring between PCME & T terminal W and fuse."]
      C -- BAD --> H["Repair or replace."]
      G -- BAD --> I["Repair or replace."]
      H -- Fuse blows again --> G
  
```

Calif. only

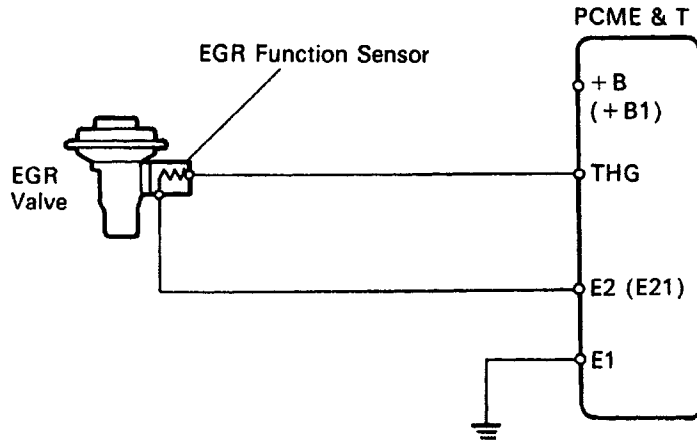

FI2680

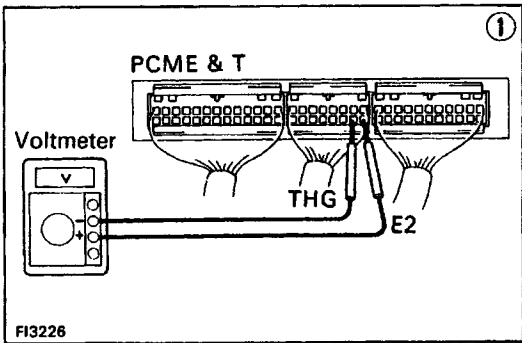

FI3226

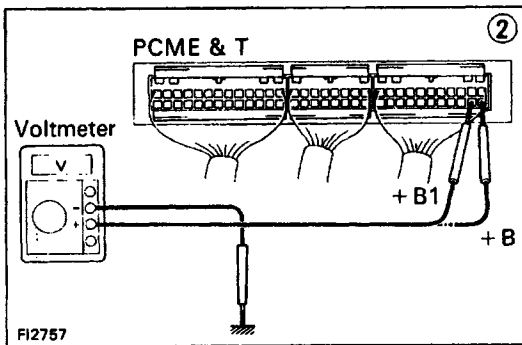

FI2757

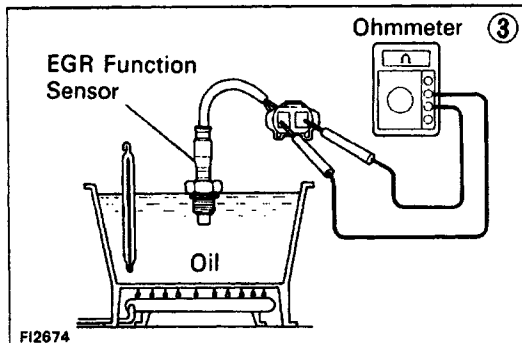

FI2674

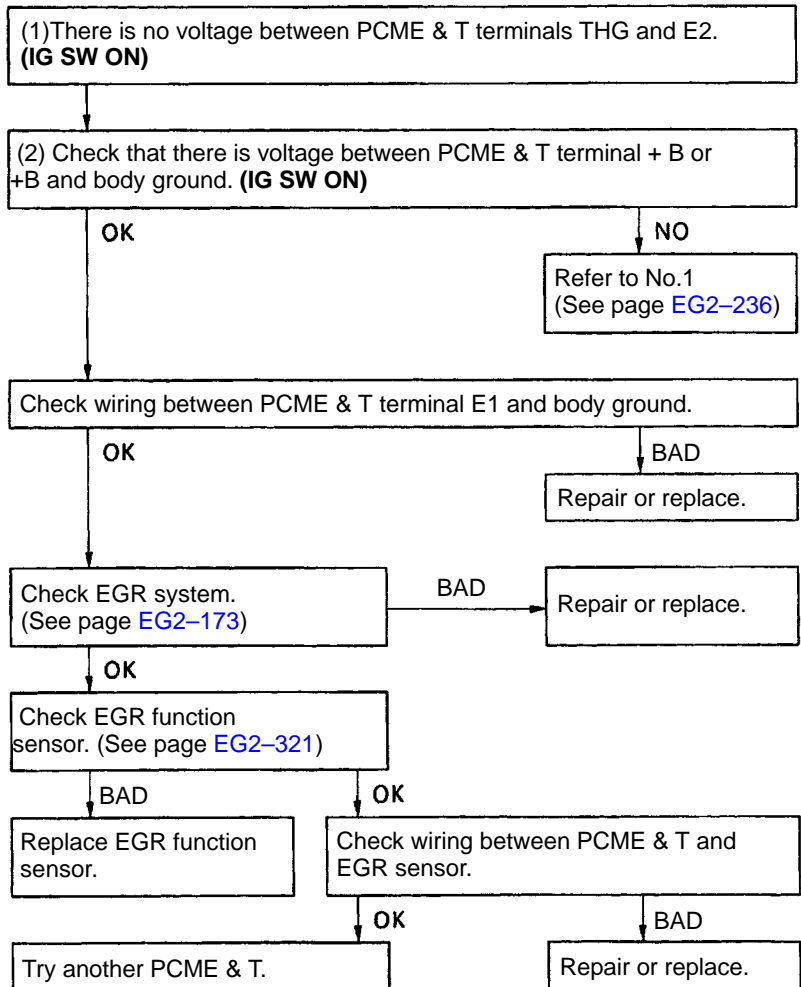



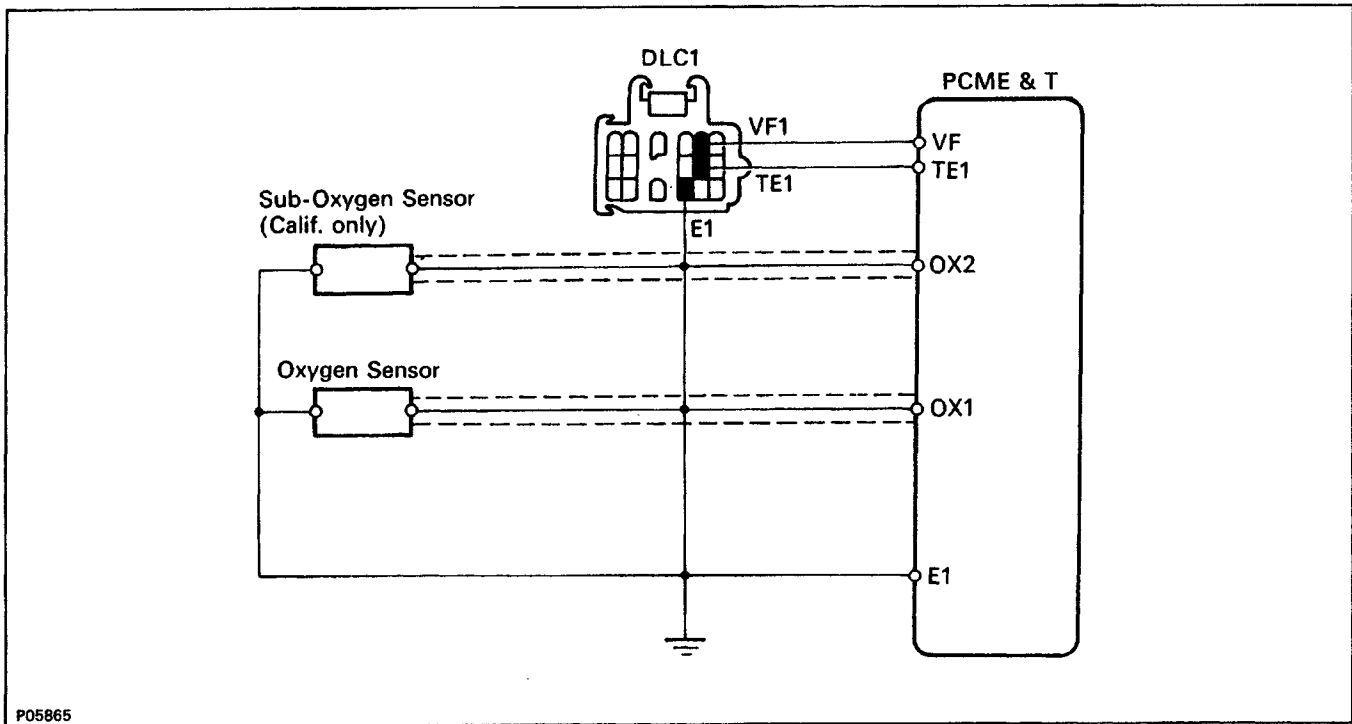

P05865

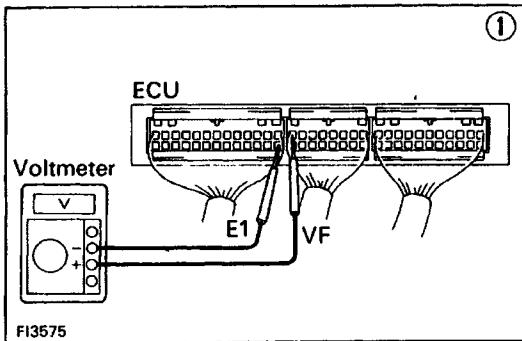

F13575

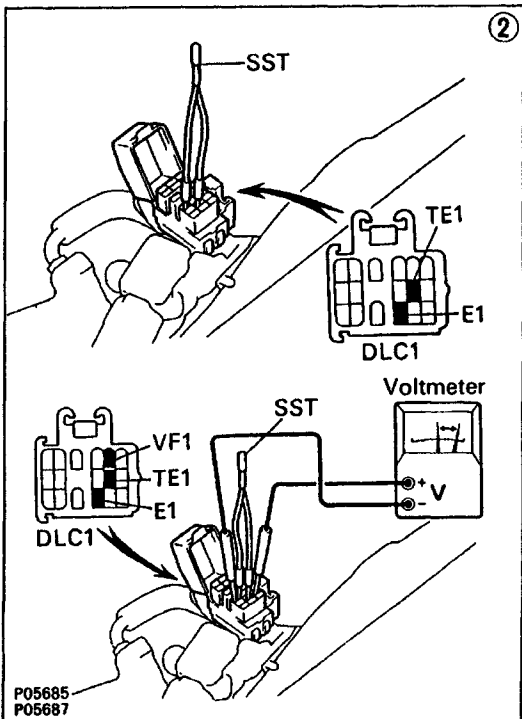

P05685  
P05687

