

A1 GENERAL INFORMATION

IMPORTANT SAFETY NOTICE-----	A1 - 1	HOW TO PROCEED DIAGNOSIS----	A1 - 16
GENERAL DESCRIPTION -----	A1 - 1	DATA LINK CONNECTOR-----	A1 - 19
WARNINGS, CAUTIONS AND		ARRANGEMENT OF DLC	
NOTES-----	A1 - 1	TERMINAL -----	A1 - 19
GENERAL WARNINGS -----	A1 - 2	HOW TO SHORT-CIRCUIT THE DLC	A1 - 19
HOW TO USE THIS MANUAL -----	A1 - 3	HOW TO SHORT-CIRCUIT USING	
ARTICLES TO BE PREPARED -----	A1 - 3	THE SST. -----	A1 - 20
REMOVAL AND INSTALLATION		HOW TO CONNECT WITH THE	
PROCEDURES-----	A1 - 3	DIAGNOSIS TESTER(DS-21/DS-II)--	A1 - 20
DESCRIPTION OF SERVICE		INSTRUCTIONS FOR SYSTEM	
STANDARD VALUE -----	A1 - 4	INSPECTION -----	A1 - 21
CONTENTS NOT DESCRIBED IN		HANDLING INSTRUCTION OF	
THIS MANUAL -----	A1 - 5	CONNECTOR -----	A1 - 21
DEFINITIONS OF TERMS-----	A1 - 5	CONNECTOR	
ABBREVIATION CODES -----	A1 - 6	REMOVAL/INSTALLATION	
HOW TO GRASP SPECIFIED		PROCEDURE -----	A1 - 21
TIGHTENING TORQUE FOR		CHECK PROCEDURE OF WIRE	
GENERAL STANDARD BOLT AND		HARNESS AND CONNECTOR-----	A1 - 23
NUT-----	A1 - 7	CIRCUIT INSPECTION OF	
DETERMINING PROCEDURE FOR		COMPUTER UNIT -----	A1 - 24
TIGHTENING TORQUE FOR		HANDLING INSTRUCTION OF	
GENERAL STANDARD BOLTS AND		SYSTEM -----	A1 - 25
NUTS-----	A1 - 7	INSTRUCTIONS FOR RADIO	
UNIT -----	A1 - 9	INSTALLATION -----	A1 - 25
NEW UNIT BECAUSE OF THE		HANDLING INSTRUCTIONS ON	
INTRODUCTION OF THE SI UNIT ----	A1 - 9	CATALYTIC CONVERTER-EQUIPPED	
PREFIX USED IN SI UNIT -----	A1 - 9	VEHICLES-----	A1 - 25
GENERAL SERVICE INSTRUCTION---	A1 - 10	PRECAUTION FOR VEHICLES	
JACK UP OR LIFT UP -----	A1 - 10	EQUIPPED WITH SRS AIRBAG AND	
INSTALLATION AND REMOVAL OF		SEAT BELT PRETENSIONER-----	A1 - 26
BATTERY TERMINAL -----	A1 - 10	INSTRUCTIONS FOR SERVICE	
CONNECTING/DISCONNECTING		OPERATION -----	A1 - 26
THE EARTH -----	A1 - 10	VEHICLE IDENTIFICATION-----	A1 - 31
REPAIRING OF FUEL SYSTEM -----	A1 - 10	BODY COLOR CODE-----	A1 - 31
USE OF THE SST-----	A1 - 11	VEHICLE IDENTIFICATION	
REMOVAL, DISASSEMBLY-----	A1 - 11	NUMBER -----	A1 - 31
CHECK AND MEASUREMENT OF		ENGINE TYPE AND ENGINE	
PARTS-----	A1 - 11	NUMBER -----	A1 - 31
INSTALLATION, ASSEMBLING-----	A1 - 11	MANUFACTURER'S PLATE	
ADJUSTMENT, OPERATION		POSITION -----	A1 - 32
CONFIRMATION-----	A1 - 11	CERTIFICATION REGULATION	
HANDLING OF HOSE OR THE LIKE	A1 - 11	PLATE POSITION-----	A1 - 33
TOUCH UP -----	A1 - 11		
SUPPORTING POINTS FOR JACKS			
AND SAFETY STANDS-----	A1 - 12		
SUPPORTING POINTS OF LIFTS -----	A1 - 14		
TOWING INSTRUCTIONS-----	A1 - 15		
TOWING WITH ROPE (ONLY FOR			
EMERGENCY) -----	A1 - 15		
USING FLAT BED TRUCK-----	A1 - 15		
WHEEL LIFT TYPE -----	A1 - 15		
DIAGNOSTICS INSTRUCTIONS -----	A1 - 16		

1 IMPORTANT SAFETY NOTICE

1-1 GENERAL DESCRIPTION

- 1.The vehicle is a machine comprising a great number of parts. Basically speaking, the vehicle is potentially hazard. However, one can handle it safely if he has the required knowledge.
2. Correct service methods and repair procedures are very vital for assuring not only the safety and reliability of a vehicle, but also the safety of service personnel concerned.
3. The methods and procedures contained in this manual describe in a general way the techniques which the manufacturer has recommended. Thus, they will contribute to ensuring the reliability of the products. The contents of the servicing operations come in a wide variety of ways. Moreover, techniques, tools and parts necessary for each operation are different widely from each other.
4. This manual does not cover all details of techniques, procedures, parts, tools and handling instructions which are necessary for these operations, for such coverage is impossible. Hence, any one who obtains this manual is expected first to make his responsible selection as to techniques, tools and parts which are necessary for servicing the vehicle concerned properly. Furthermore, he must assume responsibility for his actions in connection with his own safety.
5. Therefore, one should not perform any service if he is not capable of making responsible selection and/or if he can not understand the contents herein described, for this manual has been prepared for experienced service personnel.

1-2 WARNINGS, CAUTIONS AND NOTES

1. All these symbols have their specific purposes, respectively.

WARNING

- This symbol means that there is the possibility of personal injury of the operator himself or the nearby workers if the operator fails to follow the operating procedure prescribed in this manual.

CAUTION

- This symbol means that there is the possibility of damage to the component being repaired if the operator fails to follow the operating procedure prescribed in this manual.

NOTE

- To accomplish the operation in an efficient manner, additional instructions concerning the operation are given in this section.

1-3 GENERAL WARNINGS**1-3-1 WARNING OVER THE WHOLE SERVICE OPERATIONS**

1. Always wear safety glasses for eye protection.
2. Use safety stands whenever a procedure requires you to be under the vehicle.
3. Be sure that the ignition switch is always in the OFF position, unless otherwise required by the procedure.
4. Set the parking brake when working on the vehicle.
5. Operate the engine only in a well-ventilated area to avoid the danger of carbon monoxide.
6. Keep yourself and your clothing away from moving parts, when the engine is running, especially from the fan and belts.
7. To prevent serious burns, avoid contact with hot metal parts such as the radiator, exhaust manifold, tail pipe, catalytic converter and muffler.
8. Do not smoke while working on a vehicle.
9. To avoid injury, always remove rings, watches, loose hanging jewelry, and loose clothing before beginning to work on a vehicle.
10. Keep hands and other objects clear of the radiator fan blades! The electric cooling fan is mounted on the radiator and can start to operate anytime by a rise in coolant temperature or turning ON of the air conditioner switch in the case of vehicles equipped with an air conditioner. The electric cooling fan is also mounted on the condenser for air conditioner and starts to operate anytime when the air conditioner switch is turned ON. For this reason care should be taken to ensure that the electric cooling fan motor is completely disconnected when working under the hood.

2 HOW TO USE THIS MANUAL

2-1 ARTICLES TO BE PREPARED

When SST, tool, measuring instrument, a sort of fat and oil to be prepared before operation are necessary, those are described by compiling in the table as preparation tools at the beginning of each item. However, the general tools, jacks, fixtures as considered being equipped always at the service shop are usually omitted.

2-2 REMOVAL AND INSTALLATION PROCEDURES

1. Block diagrams are posted so as to show the installed state of each part.
2. The application of a sort of fat and oil and sealer are instructed in the figure with arrow. And the indication of a tightening torque and non-reusable parts are also described. The explanation of each code is posted below the block diagram concerned.
3. The removal and installation (Disassembling and assembling) procedure list is shown just beneath of components figure.
The removal (Disassembling) procedure, the installation (Assembling) procedure and parts name are described in the sequence from left side of list. And the alphabet written before a part name links with alphabet in the figure.
4. In principle, reverse the removal (Or disassembly) procedure to install (Or assemble) the parts.

NOTE

- Only in cases where the installation (Or assembly) can not be carried out by reversing the removal (Or disassembly) procedure, the installation (Or assembly) procedure is provided.
5. In cases where a special procedure is required for the operation, a marking "▼▲" is provided in front of the removal (Or disassembly) procedure. Furthermore, explanation is given in the "Main points of Removal (Disassembly)" or the "Main points of Installation (Assembly)."
The marking "▼" shows that there are the "Main points of Removal (Disassembly)," whereas "▲" shows that there are the "Main points of Installation (Assembly)."

2-2-1 ENTRY EXAMPLE

(1) Components

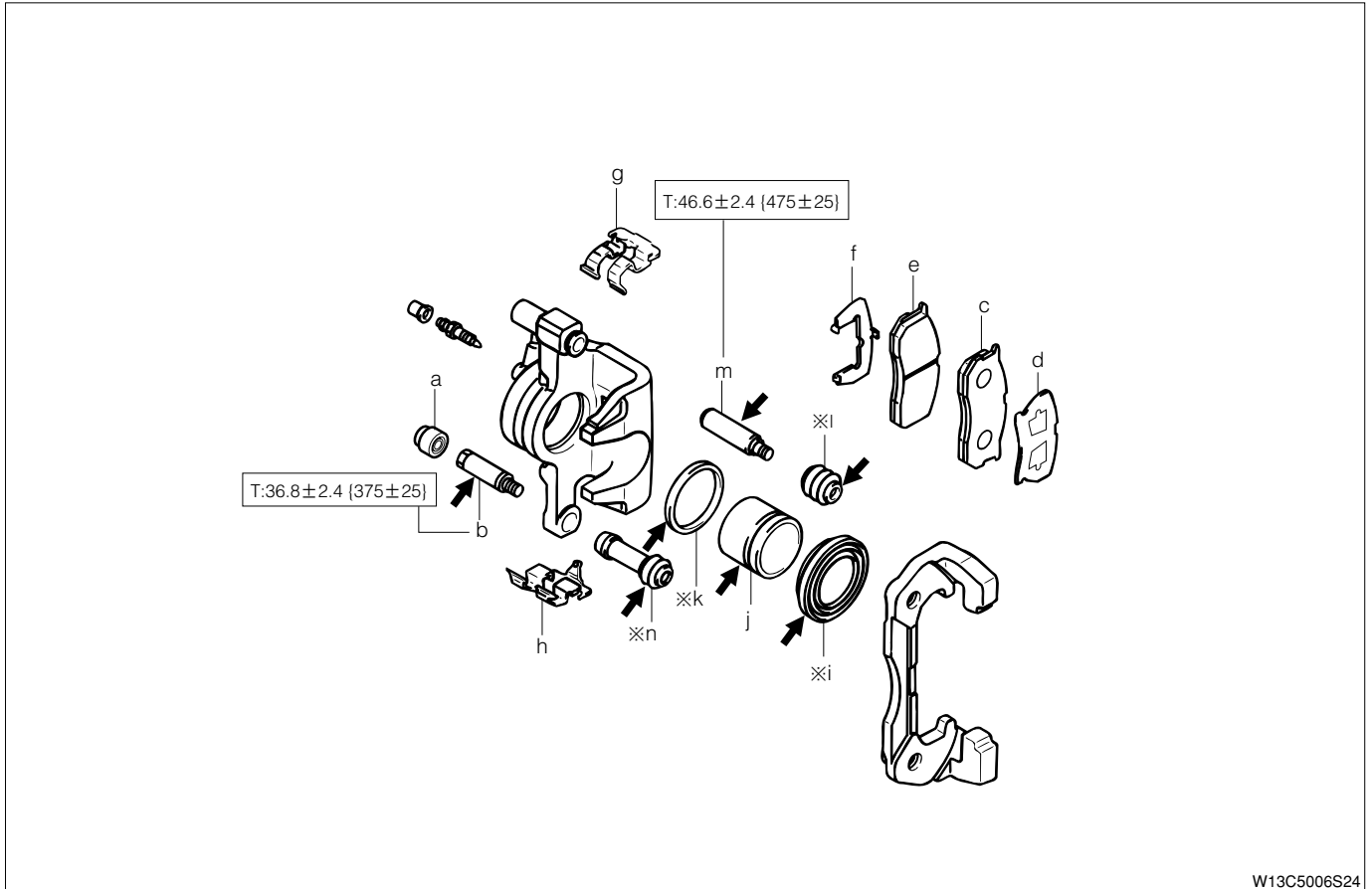

W13C5006S24

➔ : Rubber grease

※: Non-reusable part

Unit:N·m{kgf·cm}

(2) Disassembly and assembly procedures

- | | | | |
|-----|--------------------------------------|------|-------------------------------|
| 1 | a Cap, cylinder slide pin | 8 | h Plate, disc brake pad guide |
| 2 | b Pin, cylinder slide, No.1 | 9 | i Boot, cylinder |
| ▲ 3 | c Pad, disc brake, No.2 | ▼ 10 | j Piston, disc brake |
| 4 | d Shim, anti squeal, No.1 | 11 | k Seal, piston |
| ▲ 5 | e Pad, disc brake w/ indicator. No.1 | 12 | l Boot, pin |
| 6 | f Shim, anti squeal, No.1 | 13 | m Pin, cylinder slide, No.1 |
| 7 | g Plate, disc brake pad guide | 14 | n Bush, cylinder slide |

2-3 DESCRIPTION OF SERVICE STANDARD VALUE

The necessary service standard value for inspection and service operation are described with bold letter in the text as standard and allowable limit. The details of terms are described in the section for definition of terms.

A1-5

2-4 CONTENTS NOT DESCRIBED IN THIS MANUAL

The description of the next elemental operation may omit in this service manual, but please perform in an actual operation.

1. Jacking operation and lifting operation
2. Cleaning and cleansing of removed parts to perform at need
3. Visual inspection

2-5 DEFINITIONS OF TERMS

SPECIFIED VALUE	This mark shows the standard value at the time of the check or adjustment.
ALLOWABLE LIMIT	This mark shows the maximum or minimum value at the time of the check or adjustment.
DEVIATION	This value refers to the difference between the maximum clearance and the minimum clearance.
WARNING	This symbol means that there is the possibility of personal injury of the operator himself or the nearby workers if the operator fails to follow the operating procedure prescribed in this manual.
CAUTION	This symbol means that there is the possibility of damage to the component being repaired if the operator fails to follow the operating procedure prescribed in this manual.
NOTE	Supplementary explanation which facilitates the operation is posted separately from the explanation. Because of difficulties in measurements to determine specified values, there may be cases where the specified values for simple measurement methods are indicated if malfunctions are unlikely to take place actually.

3 ABBREVIATION CODES

The abbreviation codes that appear in this manual stand for the following, respectively.

ABBREVIATION CODE	ORIGINAL WORD	ABBREVIATION CODE	ORIGINAL WORD
2WD	Two Wheel Drive	LHD	Left Hand Drive
4WD	Four Wheel Drive	LIN	Local Interconnect Network
ABS	Anti-lock Brake System	LSPV	Load Sensing Proportioning Valve
ABV	Air Bypass Valve	LWR	Lower
A/C	Air Conditioner	MIL	Malfunction Indicator Lamp
ACC	Accessory	MP	Multipurpose
API	American Petroleum Institute	M/T	Manual Transmission
A/T	Automatic Transmission	N/A	Natural Aspiration
ATDC	After Top Dead Center	NOx	Nitrogen Oxides
ATF	Automatic Transmission Fluid	OPT	Option
Ay	Assembly	O/S	Over Size
BDC	Bottom Dead Center	PCV	Positive Crankcase Ventilation
BTDC	Before Top Dead Center	PR	Ply Rating
BVSV	Bimetal Vacuum Switching Valve	PTO	Power Take Off
CAN	Controller Area Network	RH	Right Hand
CD	Compact Disc	RHD	Right Hand Drive
CO	Carbon Monoxide	RR	Rear
DLC	Data Link Connector	S/A	Sub-Assembly
DLI	Distributor Less Ignition	SAE	Society of Automotive Engineers
DTC	Diagnostic Trouble Code	SRS	Supplemental Restraint System
DVVT	Dynamic Variable Valve Timing	SST	Special Service Tool
EBD	Electronic Brake force Distribution	STD	Standard
ECU	Electronic Control Unit	SW	Switch
EFI	Electronic Fuel Injection	T	Torque
EGR	Exhaust Gas Recirculation System	T/C	Turbocharger
EPS	Electronic controlled Power Steering	TDC	Top Dead Center
ESA	Electronic Spark Advance	UPR	Upper
EX	Exhaust	U/S	Under Size
F/L	Fusible Link	VCV	Vacuum Control Valve
FR	Front	VSV	Vacuum Switching Valve
GND	Ground	VTV	Vacuum Transmitting Valve
HC	Hydro Carbon	W/	With
IG	Ignition	WVTA	Whole Vehicle Type Approval
IN	Intake	ⓑ	Bolt
ISC	Idle Speed Control	Ⓢ	Screw
ISO	International Organization for Standardization	Ⓝ	Nut
LCD	Liquid Crystal Display	Ⓦ	Washer
LED	Light Emitting Diode	©	Clip
LH	Left Hand		

4 HOW TO GRASP SPECIFIED TIGHTENING TORQUE FOR GENERAL STANDARD BOLT AND NUT

4-1 DETERMINING PROCEDURE FOR TIGHTENING TORQUE FOR GENERAL STANDARD BOLTS AND NUTS

4-1-1 DETERMINING PROCEDURE FOR TIGHTENING TORQUE FOR BOLTS

Determine the strength division of bolts, based on the table below.











Then, obtain the value, based on the tightening torque table.

4-1-2 DETERMINING PROCEDURE FOR TIGHTENING TORQUE FOR NUTS

Determine with the aforesaid method, based on the mating bolt.

4-1-3 IDENTIFICATION

Identification of strength division by checking bolts themselves

Classification (Strength division)	Shape of head (how to know strength division)	
	Bolt without collar	Bolt with collar
4 T	 	 
5 T	 	—
6 T	— —	 
7 T	 	—

Identification by part number

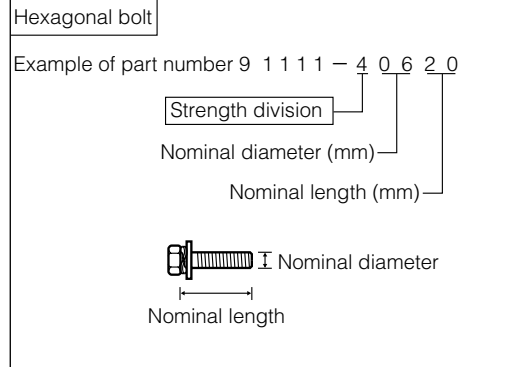

4-1-4 TIGHTENING TORQUE TABLE FOR GENERAL STANDARD BOLTS

Strength divisin	Nominal diameter (mm)	Pitch (mm)	Standard tightening torque (N·m{kgf·cm})	
			Bolt without collar	Bolt with collar
4 T	6	1.0	5.4 {55}	5.9 {60}
	8	1.25	13 {130}	14 {145}
	10	1.25	25 {260}	28 {290}
	12	1.25	47 {480}	53 {540}
	14	1.5	74 {760}	83 {850}
	16	1.5	113 {1150}	—
5 T	6	1.0	6.4 {65}	—
	8	1.25	16 {160}	—
	10	1.25	32 {330}	—
	12	1.25	59 {600}	—
	14	1.5	91 {930}	—
	16	1.5	137 {1400}	—
6 T	6	1.0	7.8 {80}	8.8 {90}
	8	1.25	19 {195}	20.5 {210}
	10	1.25	39 {400}	43 {440}
	12	1.25	72 {730}	79 {810}
	14	1.5	109 {1100}	123 {1250}
7 T	6	1.0	11 {110}	12 {120}
	8	1.25	25 {260}	28 {290}
	10	1.25	52 {530}	58 {590}
	12	1.25	95 {970}	103 {1050}
	14	1.5	147 {1500}	167 {1700}
	16	1.5	225 {2300}	—

4-1-5 WHEN AN EXTENSION TOOL IS USED

1. When tightening with the SST or a tool connected to the torque wrench for a drive-end extension, a higher tightening torque will result, if tightened until the reading on the torque wrench indicates the specified torque.
2. This manual contains specified torques only. When using the SST or an extension tool, the torque wrench reading must be computed using the following formula.
3. Calculation formula: $T' = T \times B / (A + B)$

Codes	Meaning	Unit
T'	Torque wrench reading	N·m{kgf·cm}
T	Specified tightening torque	N·m{kgf·cm}
A	Length of the SST or a tool	cm
B	Torque wrench length	cm

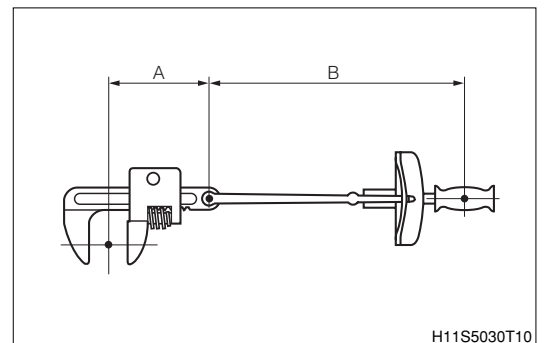

5 UNIT

As for the units, the SI units (International unit system) have been posted. (The hitherto—employed units, too, are posted.)

Example: $33.25 \pm 13.25 \text{N} \cdot \text{m} \{340 \pm 135 \text{kgf} \cdot \text{cm}\}$

5-1 NEW UNIT BECAUSE OF THE INTRODUCTION OF THE SI UNIT

1. SI unit is the international unit system established by aiming to proceed the communication in technology smoothly by unifying the former unit system which were different internationally each other into one value by one unit. The specification value is described in accordance with SI unit system in this service manual.

ITEM	SI unit	Conventional units	Conversion table
Force	N	kgf	1kgf = 9.80665 N
Torque	N·m	kgf·cm	1kgf·cm = 0.0980665 N·m
Pressure	kPa	kgf/cm ²	1kgf/cm ² = 98.0665 kPa
		mmHg	1mmHg = 0.133322 kPa
Spring constant	N/mm	kgf/mm	1kgf/mm = 9.80665 N/mm
Volume	ℓ	cc	1000cc = 1ℓ
Power	kW	PS	1PS = 0.735499 kW

5-2 PREFIX USED IN SI UNIT

The following are typical prefixes used in SI Unit (10 to the power of n).

M (mega)	10^6
k (kilo)	10^3
h (hecto)	10^2
da (deca)	10^1
d (deci)	$10^{-1} = 0.1$
c (centi)	$10^{-2} = 0.01$
m (milli)	$10^{-3} = 0.001$
μ (micro)	$10^{-6} = 0.000001$

6 GENERAL SERVICE INSTRUCTION

6-1 JACK UP OR LIFT UP

1. When only front section or rear section of a vehicle is jacked up, be sure to place chocks at the wheels so as to insure safe operations.
2. When the vehicle has been jacked up, be sure to support the vehicle at the specified section using the safety stands.
3. When the vehicle has been lifted up, be sure to set the cradle of the lift at the specified location, and lift it up. And after the jacking up, ensure to apply the protective safety device.
And after the jacking up, ensure to apply the protective safety device.

6-2 INSTALLATION AND REMOVAL OF BATTERY TERMINAL

1. Disconnect the battery negative (-) terminal prior to repairing the electrical system, mounting/dis-mounting the engine, etc.
2. When connecting/disconnecting the battery terminal, turn the IG switch to OFF (LOCK position), and loosen the terminal nut completely. Do not pry the battery terminal off.
3. When the battery terminal is removed, clock, radio setup and the memory of diagnosis will be erased. Record the contents of the memory before disconnecting the battery terminal so that it can be restored as required after the work is complete.
4. When connecting the battery terminal, connect the positive (+) terminal first so that that the terminal wire will be placed in the marked area of the illustration, and tighten to the specified torque.

TIGHTENING TORQUE: $6.35 \pm 1.45 \text{ N} \cdot \text{m}$
{ $65 \pm 15 \text{ kgf} \cdot \text{cm}$ }

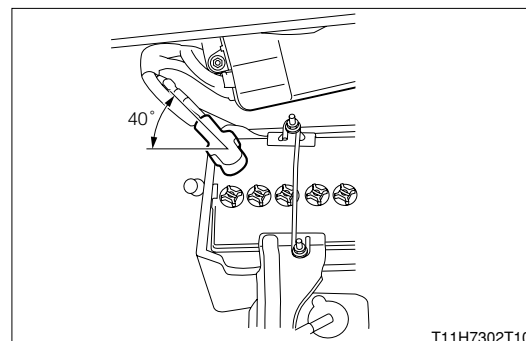

5. When connecting the battery negative (-) terminal, connect the terminal so that that the terminal wire will be placed in the marked area of the illustration, and tighten to the specified torque.

TIGHTENING TORQUE: $6.35 \pm 1.45 \text{ N} \cdot \text{m}$
{ $65 \pm 15 \text{ kgf} \cdot \text{cm}$ }

6. Securely install the cover, etc. on the terminal after work is complete.

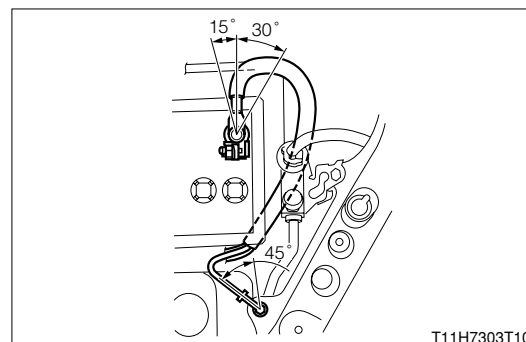

6-3 CONNECTING/DISCONNECTING THE EARTH

1. When the earth was removed, check that the earth is securely in place and then turn ON the IG switch.

6-4 REPAIRING OF FUEL SYSTEM

1. Do not work near open flames.
2. Be certain to place a suitable container, a cloth, etc. under the connected section of the fuel line before disconnecting the fuel line.
3. Before the fuel line is disconnected, be sure to release the inner pressure of the fuel tank by detaching the fuel filler cap.
4. Be sure to prevent the fuel from splashing with a cloth or the like, when the union bolt or other connected section of the fuel line is loosened or slackened.
5. Tighten each connecting section to the specified torque.
6. Attach the specified clips to each connecting section.

A1-11

6-5 USE OF THE SST

- 1.Utilize the SST (Special tool) effectively in order to improve efficiency and accuracy of work operation.

6-6 REMOVAL, DISASSEMBLY

- 1.In case for the operation at the complicate place, the stamping and mating mark shall be put at the place where there is no influence to the function, so that the assembling operation becomes easy.
- 2.At every time when each parts are removed, check the condition when it was assembled , deformation, breakage, roughness and existence of scratch .
- 3.Arrange the removed parts in order, and divide them to the parts to replace and parts to reuse .
- 4.Each parts to be reused shall be performed enough cleaning and cleansing operation.

6-7 CHECK AND MEASUREMENT OF PARTS

- 1.As regards those parts to be used again, perform thorough checks and measurements, as required.

6-8 INSTALLATION, ASSEMBLING

- 1.Assemble the good parts with correct procedure following the specified standard (Value for the adjusting , tightening torque).
- 2.Use the genuine parts when replace the parts.
- 3.Ensure to apply the seal packing and grease by a place.
- 4.Ensure to use new packing, gasket or the like, cotter pin etc.
- 5.When use the seal bolt, apply the specified liquid gasket and seal lock agent on.
- 6.As for bolts and nuts, use the specified ones. Unless otherwise specified, the side for which the torque is indicated should be tightened to the specified torque, using a torque wrench. If there is no means to prevent the turning at the opposite side, be sure to prevent turning with box wrenches, spanners or the like.

6-9 ADJUSTMENT, OPERATION CONFIRMATION

- 1.Adjust with the specified service standard value by using the gauge and the tester.

6-10 HANDLING OF HOSE OR THE LIKE

- 1.Check the plug depth and clamp position before removing the hose.
- 2.When re-using the hose, install the clamps so that they match the clamp marks remaining on the hose.

CAUTION

- Replace the clamps if they are deformed or flattened.
- Replace the hose a new one if the hose has a loose fitting with the joint.

- 3.Ensure that the spring type clamp is properly seated after installation.
- 4.Ensure to insert the fuel hose, water hose or the like without coming out or leakage.
- 5.Be careful that fuel shall not splash on the parts near by when remove the fuel hose. (Deep care shall be paid for engine mount rubber or the like, as there may be possibility to get material deterioration for liquid of gasoline series.)

6-11 TOUCH UP

- 1.When removed the bolt or the like during body fitting operation and others, the scratch of the paint finishing surface on the body and bolt shall be repaired by the body color.

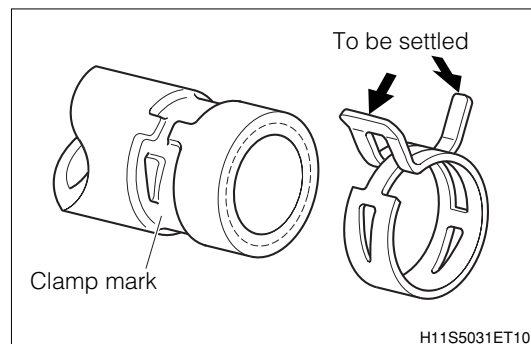

7 SUPPORTING POINTS FOR JACKS AND SAFETY STANDS

- Jack supporting point

Front side: Front suspension member center protruding section

Rear side: Rear floor cross member center section

CAUTION

- Do not jack up the rear suspension center beam portion.
Deformation and/or damage to the beam might cause controllability problems.

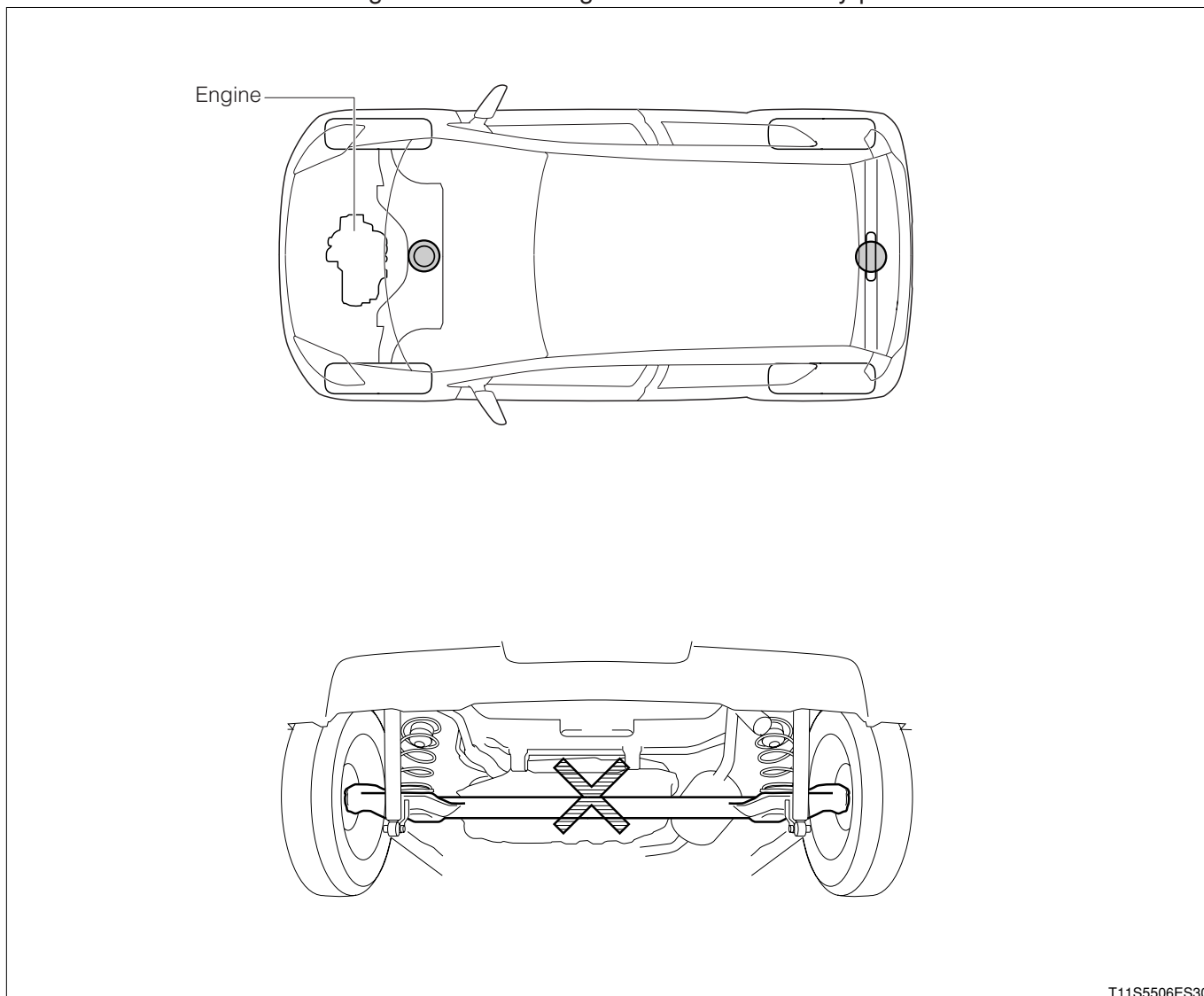

A1-13

- Rigid rack supporting points

Support 4 locations, namely front, rear, right and left as shown in the illustration below.

CAUTION

- The spot welded reinforcement plate provides adequate strength to the supporting points. Therefore, do not support the vehicle at points other than these supporting points.

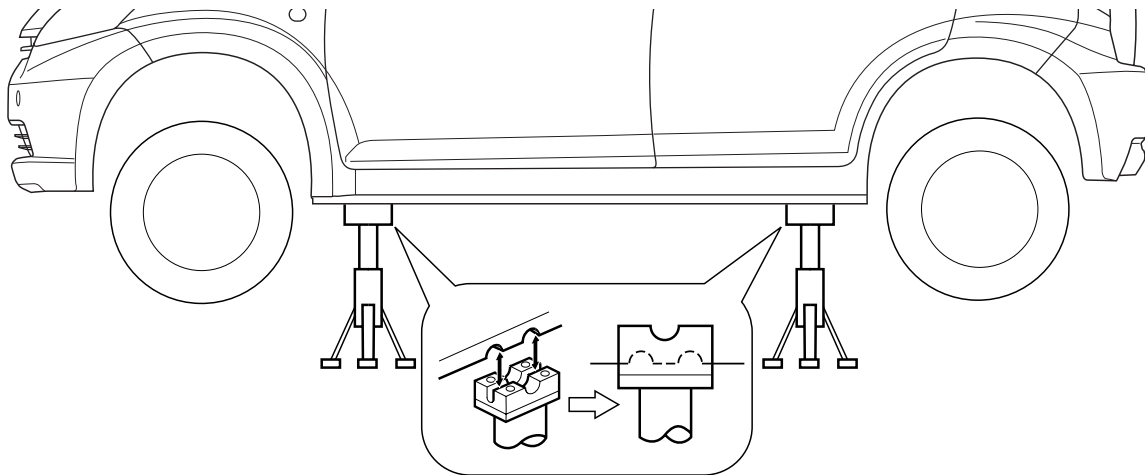
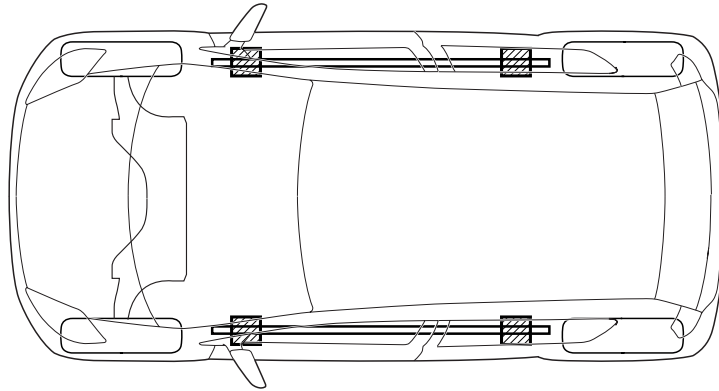

8 SUPPORTING POINTS OF LIFTS

- Swing Arm Type

Match the lift supports with the rigid rack supporting points.

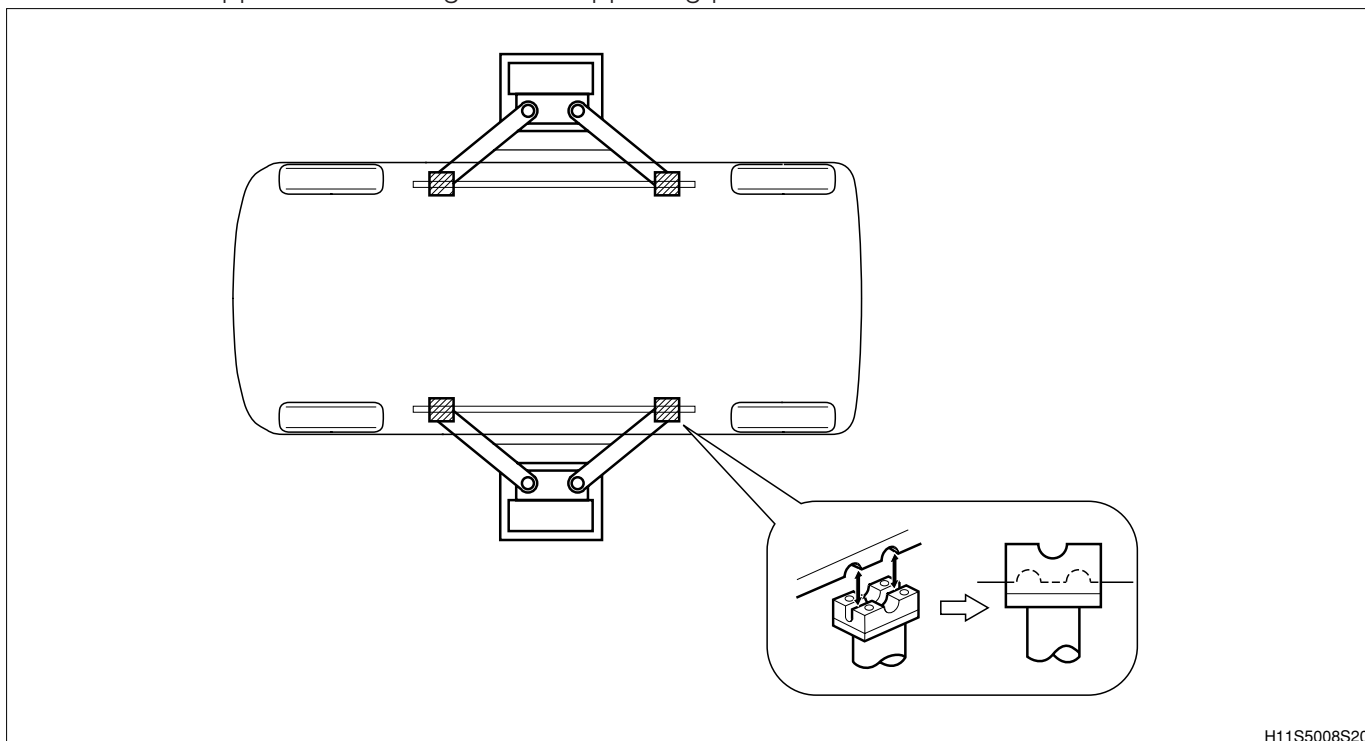

H11S5008S20

- Plate type

Drive the vehicle onto the center of the right and left supports.

Since the front part is heavier, lift up the vehicle at the front where ever possible.

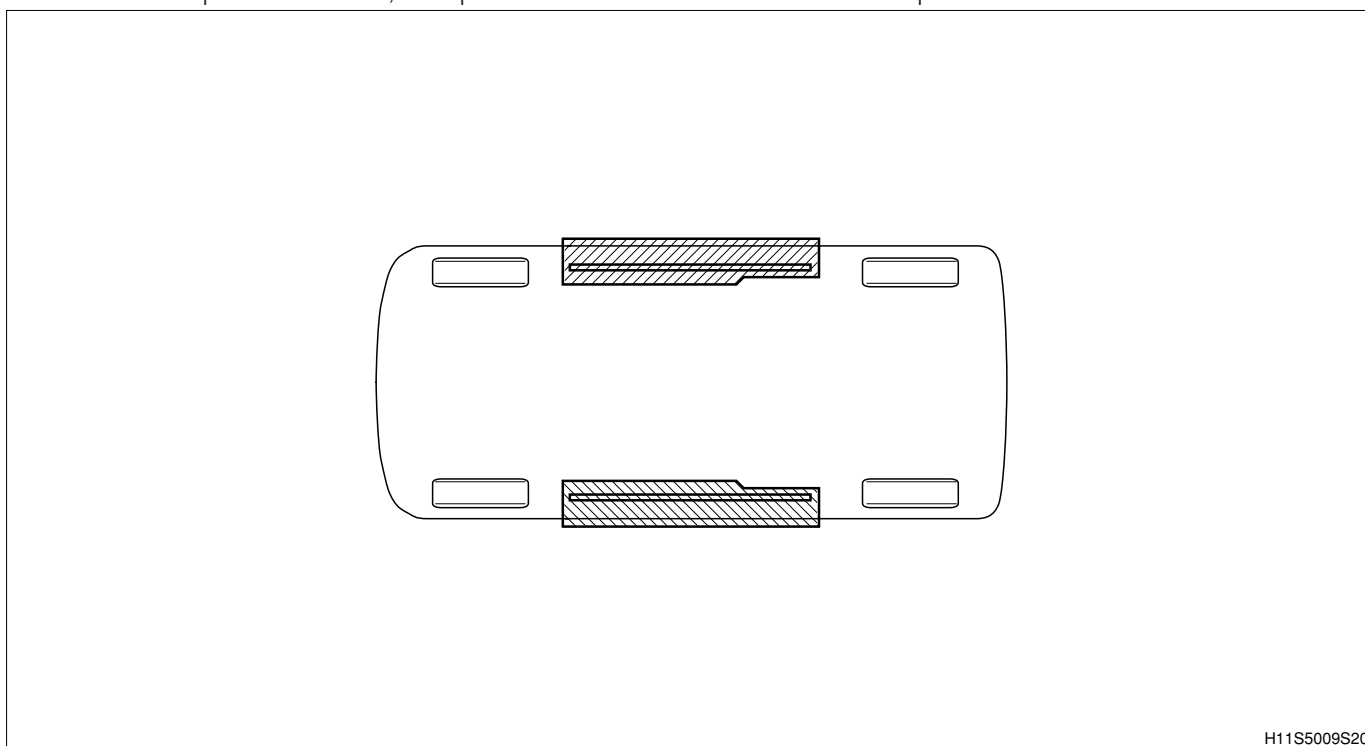

H11S5009S20

9 TOWING INSTRUCTIONS

1. Be certain to transfer the vehicle by using the flat deck truck when the running system and/or driving system seems to be abnormal.
2. Do not tow with the rope for an automatic transmission vehicle.

9-1 TOWING WITH ROPE (ONLY FOR EMERGENCY)

Release parking brake, and turn IG switch to ACC position, and then put the shift lever into neutral range.

CAUTION

- Do not tow with the rope for an automatic transmission vehicle.
- Do not tow with the rope when the running system and/or driving system seems to be abnormal.
- When drive with engine stopping, brake efficiency become less due to no functioning of the brake servo system. Depress the brake pedal more powerfully than the usual.

9-2 USING FLAT BED TRUCK

1. Transfer the vehicle with applying parking brake and fixing the vehicle firmly.

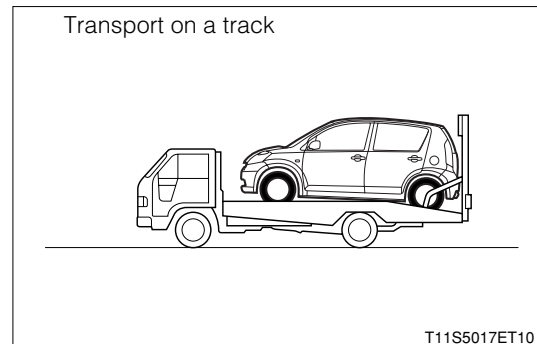
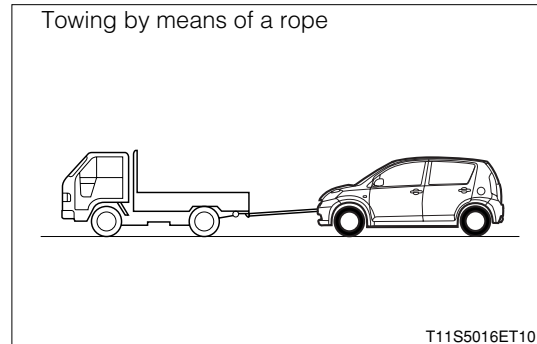

9-3 WHEEL LIFT TYPE

CAUTION

- Do not allow anyone to be in the vehicle being towed.

9-3-1 TO TOW WITH REAR WHEELS ON GROUND

1. Release the parking brake.

9-3-2 TO TOW WITH FRONT WHEELS ON GROUND

1. Use a towing dolly.
2. If a towing dolly is not available, and turn IG switch to ACC position, and then put the shift lever into neutral range (For manual transmission vehicle).

CAUTION

- For an automatic transmission vehicle, be sure to always use a towing dolly.

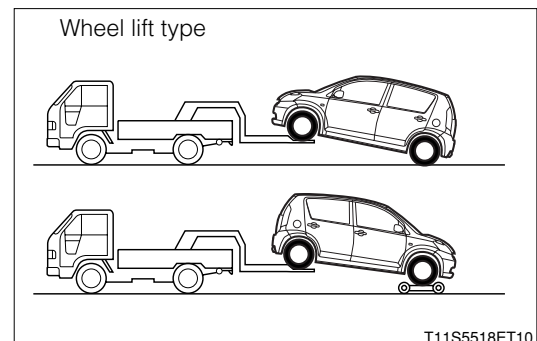

10 DIAGNOSTICS INSTRUCTIONS

10-1 HOW TO PROCEED DIAGNOSIS

1. Each electronic control system equipped on the vehicle is an important clue at performing trouble shooting. Also this system has self-diagnosis function to inspect the malfunction portion which occurred in corresponding system, and battery back up (The function that power source for diagnosis code memory is supplied even if IG switch is OFF) is equipped for self-diagnosis function of electronic control system with, and is designed so that diagnosis code is memorized to each system. As the function of diagnosis code memory is different by each system, perform the confirmation / elimination of code memory according to the right operation procedure after confirming equipped diagnosis code memory function.

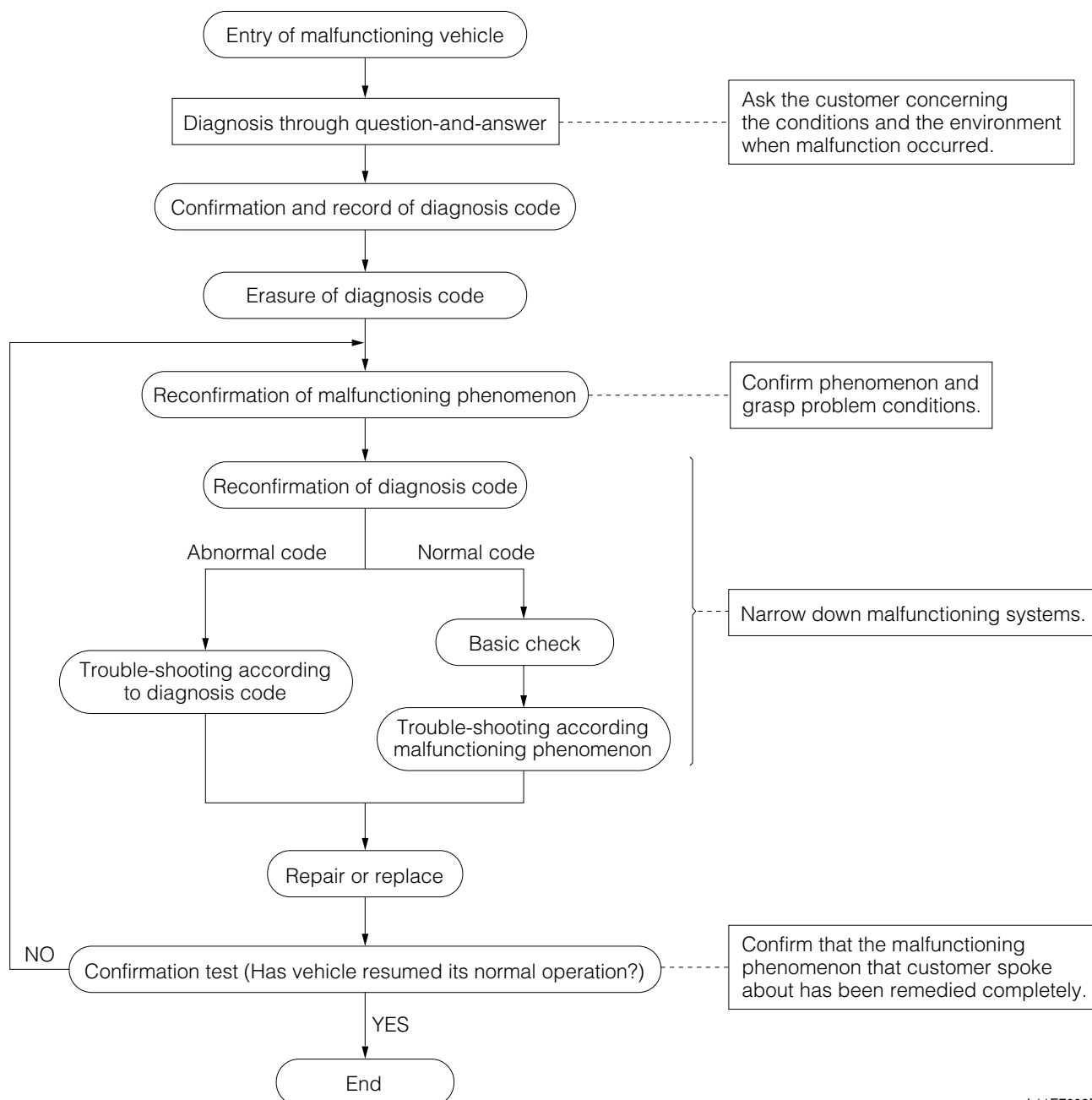

10-1-1 SYMPTOM CONFIRMATION

1. When conducting a trouble shooting, the operator cannot pinpoint the cause for the malfunction, unless he actually confirms the phenomenon. For this purpose, it is indispensable to reproduce the malfunctioning phenomenon by creating conditions and environments that are similar to those where the malfunction actually took place, based on the information obtained through the inquiry with the customer. As for phenomena which cannot be reproduced easily, it is necessary to produce running conditions that are close to those when the malfunction took place (Road surface condition, weather condition, and driving condition), based on the information obtained through the inquiry with the customer. To this end, it is of great importance to try to reproduce the malfunction persistently by applying external factors, such as vibration (Moving wire harnesses and relays by hand), heat (Applying hot air), and water (Applying moisture). Furthermore, while the malfunction phenomenon is being reproduced, it is essential to check diagnosis codes indicated before and after the confirmation of the malfunction phenomenon. Checking whether the code that was indicated before the confirmation is outputted or not is also an important step for confirming the malfunction phenomenon.

10-1-2 CUSTOMER PROBLEM ANALYSIS

1. For the vehicle which malfunctions occurred, confirm first the malfunction phenomenon, and study the cause and then eliminate the cause. There is possibility that the vehicle does not return to normal condition even if perform many operation without study of cause. An asking about problems is to gather the information from the customer before confirming the malfunction phenomenon, and become an important clue when attempt to reproduce the malfunction. When perform the asking about problem, it is necessary to focus to the items relating to said malfunctions so that information attained with an asking about problems becomes useful reference of trouble shooting.

10-1-3 HOW TO REPRODUCE

The following shows how to reproduce the malfunction phenomenon hard to reproduce with the vehicle stopped by applying external factors (Vibration, heat, water, etc.).

(1) Vibration method (When it is presumed that failure occurs due to vibration)

① Harness

Check to see if malfunction takes place by lightly swinging the wire harness vertically and laterally.

CAUTION

- In the case of harnesses, focus on checking the neck of the connector, a fulcrum of vibration, body pass-through section.

② Connector

Lightly swing the connector vertically and laterally.

(2) Hot/cold temperature method (When it is presumed that failure occurs at hot/cold temperatures)

With a hair dryer or refrigerant, heat or cool the parts of the system thought to be responsible for the malfunction. See if the malfunction is reproduced.

CAUTION

- When heating, do not heat the part beyond +60°C (Temperature at which the part can be touched by hand).
- Do not open the cover for the sensor, ECU, etc. to directly heat or cool the electronic components.

(3) Water spray method (When it is presumed that failure occurs on rainy or humid days)

Apply water to the vehicle and see if the malfunction takes place.

CAUTION

- Do not apply water directly to electronic parts.

NOTE

- If rain leak takes place inside the vehicle, the rainwater may go along the harness, entering the inside of the parts. This should be kept in mind especially when the vehicle has had rain leak before.

(4) Others (When it is presumed that failure occurs due to excess electrical load)

Increase the electric load by operating the electric parts, such as the heater blower, headlamps, and rear defogger. See if the malfunction takes place.

11 DATA LINK CONNECTOR

11-1 ARRANGEMENT OF DLC TERMINAL

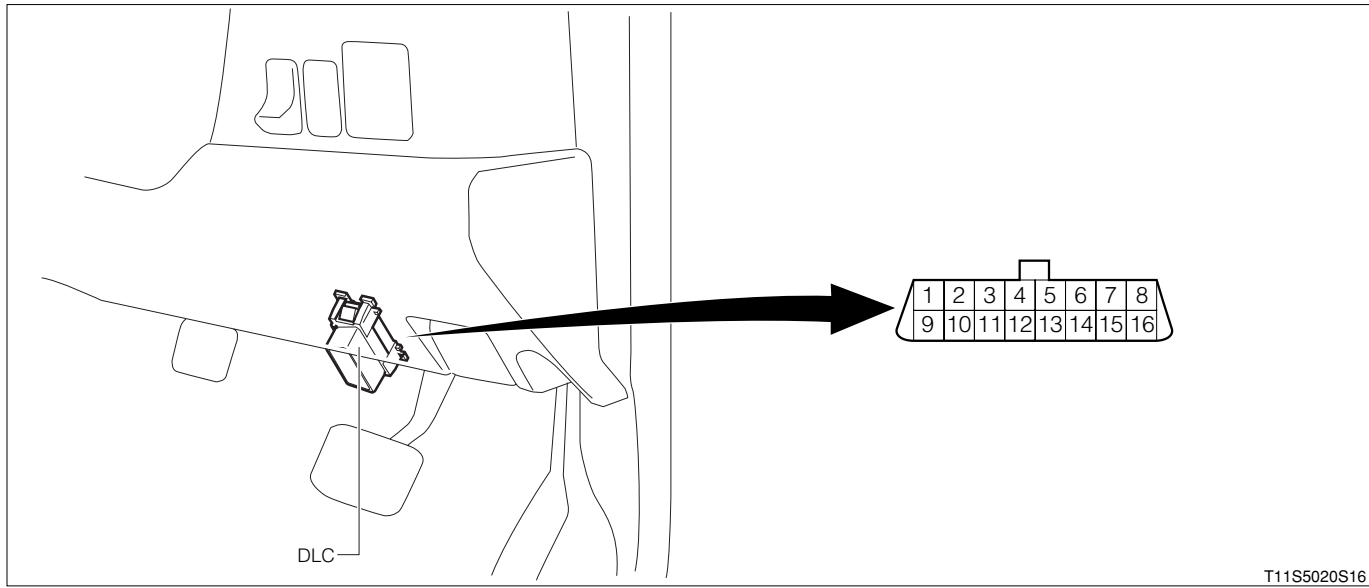

T11S5020S16

Terminal No.	Terminal code	Terminal name	Terminal No.	Terminal code	Terminal name
1	BAT	Battery power supply	9	—	—
2	—	—	10	SIO	DS-21 communication
3	CANL	CAN communication LO	11	CANH	CAN communication HI
4	ECU-T	ECU-T check terminal	12	E	Signal earth
5	EFI-T	EFI-T check terminal	13	E	Body earth
6	—	—	14	EPS-TS	EPS-TS check terminal
7	—	—	15	—	—
8	REV	Engine revolution speed signal	16	—	—

11-2 HOW TO SHORT-CIRCUIT THE DLC

Connect the engine control system inspection wire (SST:09991-87404-000).

Use the short-circuit terminal (SST:09991-87403-000) and engine speed sensing terminal (SST:09991-87402-000) to perform system check for each system.

11-3 HOW TO SHORT-CIRCUIT USING THE SST.

1. Diagnostic code output of the engine control system
 - Short circuit between 5 (EFI-T) - 13(E)
2. Oxygen sensor operation check of the engine control system
 - Short circuit between 5 (EFI-T) - 13(E)
3. Engine speed check of the engine control system
 - Measure between 8(REV) and the body earth.
4. Diagnostic code output of the electric power steering
 - Short circuit between 14 (EPS-TS) - 13(E), and release the short circuit.
5. Diagnostic code output of the A/T control system
 - Short circuit between 4 (ECU-T) - 13(E).
6. Diagnostic code output of the ABS system
 - Short circuit between 4 (ECU-T) - 13(E).
7. Diagnostic code output of the SRS airbag system
 - Short circuit between 4 (ECU-T) - 13(E)
8. Operation check of the ITC computer and the hazard lamp system
 - Short circuit between 4 (ECU-T) - 13(E).
9. Diagnostic code output of the immobilizer system
 - Short circuit between 4 (ECU-T) - 13(E).
10. Diagnostic code output of the CAN communication system
 - Short circuit between 4 (ECU-T) - 13(E).
11. Diagnostic code output of the LIN communication system
 - Short circuit between 4 (ECU-T) - 13(E)
12. Diagnostic code output of the meter system
 - Short circuit between 4 (ECU-T) - 13(E).

11-4 HOW TO CONNECT WITH THE DIAGNOSIS TESTER(DS-21/DS-II)

Connect the engine control system inspection wire (SST:09991-87404-000).

NOTE

- A terminal to communicate with the diagnosis tester (DS-21/DS-II) is installed to the DLC (Vehicles side).

12 INSTRUCTIONS FOR SYSTEM INSPECTION

12-1 HANDLING INSTRUCTION OF CONNECTOR

1.Connection or disconnection of the connector and each terminal shall be performed basically after the removal of negative terminal of the battery.

However, there may be the case that diagnosis code is erased when remove the negative terminal of battery, so confirm the diagnosis code first before the removal of battery negative terminal when need to confirm.

2.When disconnecting connectors, be sure to hold the connector itself with the connector unlocked.

Never pull harnesses. When connecting connectors, be sure to positively insert the connectors, until you hear a clicking sound and the lock is engaged.

3.When inserting tester probes into a connector, insert them from the rear side of the connector.

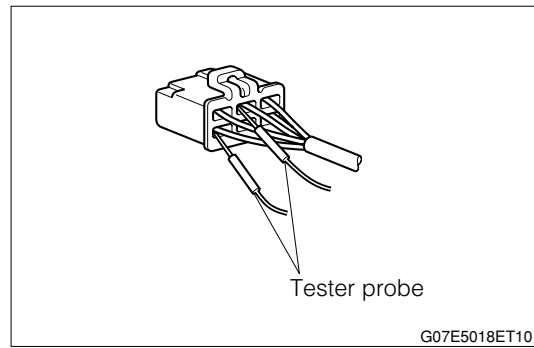
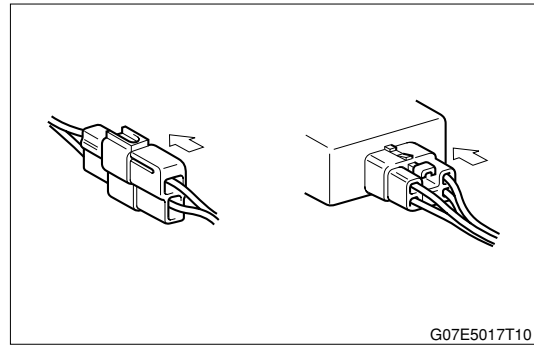

4.For water—proof connectors which cannot be accessed from behind, take good care not to deform the connector terminals.

5.Never touch the terminal of connector directly by hand.

6.When a tester probe is applied to a terminal to which voltage is applied, care must be exercised so that two tester probes may not come in contact with each other so that short circuit may not take place.

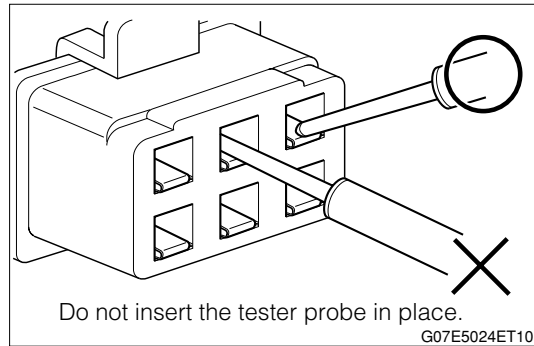

12-2 CONNECTOR REMOVAL/INSTALLATION PROCEDURE

12-2-1 CONNECTOR WITH LOCKING BUTTON

(1) Type 1

① Points of removal

1.Insert a flat screwdriver with a thin forward end (Approx. 2 mm wide) into the locking button at the point A. Raise the locking button, utilizing lever principle, until you hear a clicking sound, thus unlocking the connector.

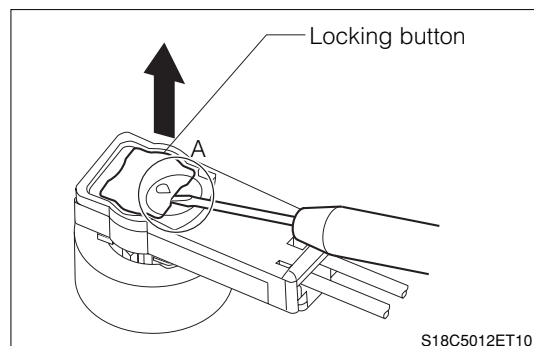

2. Insert a flat screwdriver with a thin forward end (Approx. 2 mm wide) at the point B or C. Pry the point with the screwdriver in the arrow direction, utilizing lever principle, thus removing the connector.

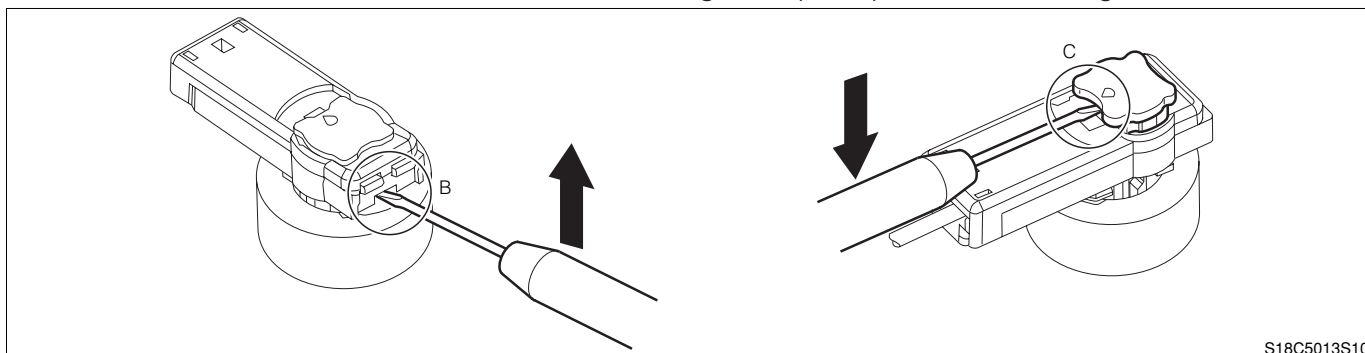

S18C5013S10

② Points of installation

1. Insert the connector firmly as far as it goes. Push and lock the connector, until the locking button clicks.

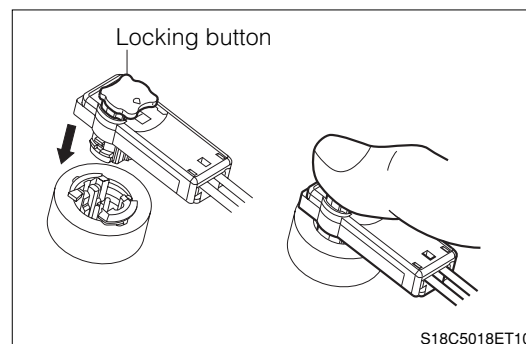

S18C5018ET10

(2) Type 2

① Points of removal

1. With a flat screwdriver with a thin forward end, pull out the locking button in the arrow direction, thus unlocking the lock. Then, remove the connector.

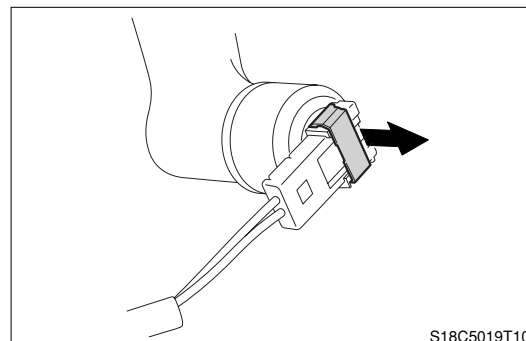

S18C5019T10

② Points of installation

1. Insert the connector firmly as far as it goes. Push and lock the connector, until the locking button clicks.

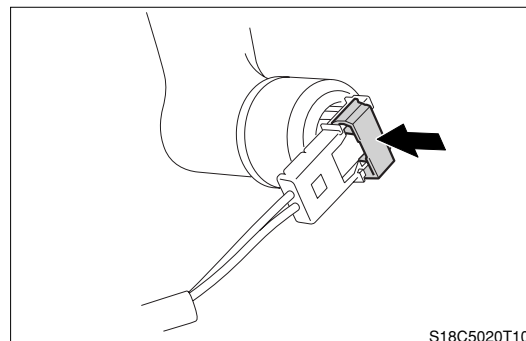

S18C5020T10

12-2-2 CONNECTOR WITH LEVER LOCK

(1) Points of removal

1. Push the lock of the lever section in the arrow direction, thus unlocking the lock.

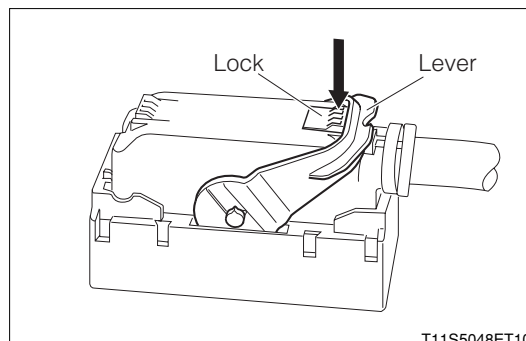

T11S5048ET10

2. Turn the lever securely in the direction A to remove the connector.

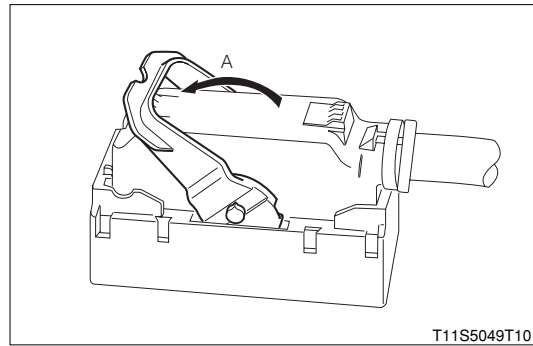

(2) Points of installation

1. Insert the connector to the mating side. Turn the lever in the direction A to lock the connector.

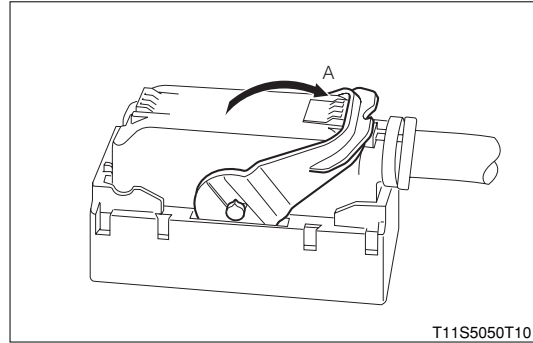

12-3 CHECK PROCEDURE OF WIRE HARNESS AND CONNECTOR

Perform the inspection of wire harness and connector portion in the distinctive system inspection in accordance with next points.

12-3-1 CONTINUITY INSPECTION

1. Remove the connector of corresponding harness on both ends.
2. Measure the electrical resistance between corresponding terminals of connector on both end.

SPECIFIED VALUE: Not more than $1\ \Omega$

CAUTION

- Measure the electrical resistance while shaking wire harness in top and down and right and left lightly.

NOTE

- In case of open circuit, as it is seldom that open circuit happen in central part of wiring harness, and most of part the open circuit happen are connector area. Particularly, check the connector of the sensor portion carefully.

12-3-2 SHORT CIRCUIT INSPECTION

1. Remove the connector of corresponding harness on both end.
2. Measure the electrical resistance between corresponding terminal of connector and body earth connecting. In addition to above, perform the inspection with the connector of each side.

SPECIFIED VALUE: Not less than $1\text{M}\ \Omega$

CAUTION

- Measure the electrical resistance while shaking wire harness in top and down, and right and left lightly.

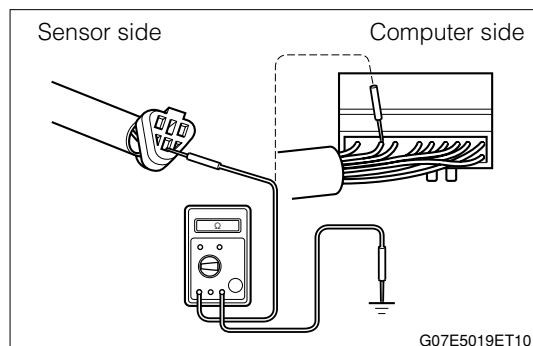
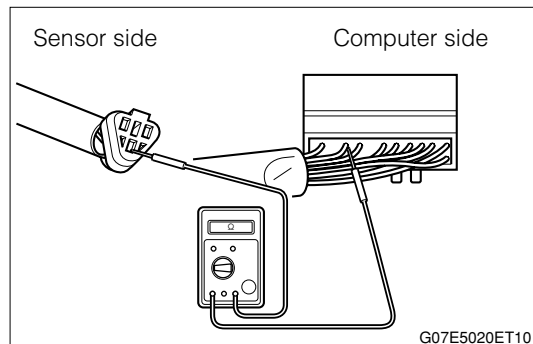

3. Measure electrical resistance between terminals in same connector with the connector of corresponding terminal (Except between each power supply lines or earth lines). In addition to above, perform the inspection at the connector of both sides.

SPECIFIED VALUE: Not less than $1M\Omega$

CAUTION

- There may be short circuits due to wiring in the vehicle compartment which is pinched by the body or faulty clamps.

12-3-3 VISUAL INSPECTION, CONTACT FORCE INSPECTION

1. Remove the connector of corresponding harness on both end .

2. Check visually the rust generation or mixing of the foreign material at connector terminal portion.

3. Check whether there are looseness, damage at the staking portion and check coming out from the coupler by pulling the wire harness lightly .

4. Prepare the same male terminal as that of the connector terminal. Insert it into the female terminal and check the pulling force.

The terminal having a smaller pulling force, compared with other terminals, may cause poor contact.

CAUTION

- If the terminal section has rust formation, admission of foreign matters or poor contact pressure between the male terminal and the female terminal, the contact condition may change by disconnecting and reconnecting the connector once, thus resulting in No malfunction.

Therefore, if the check of the wire harness and connector reveals that there is no malfunction, confirm the malfunction phenomenon. At this time, if no malfunction phenomenon is reproduced, most likely the poor contact between the male terminal and the female terminal was causing the malfunction.

12-4 CIRCUIT INSPECTION OF COMPUTER UNIT

Perform computer unit circuit inspection. If it is malfunction, repair the corresponding connector, circuit, and if normal, change the computer unit.

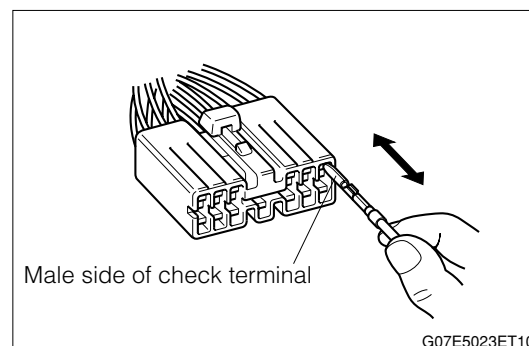
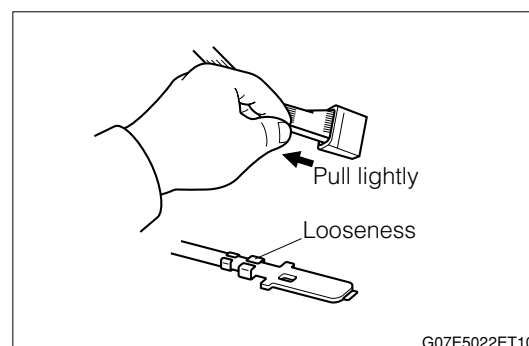
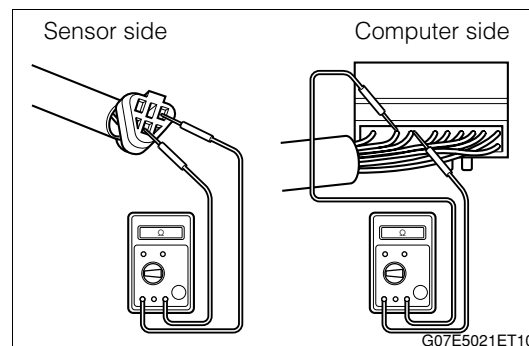

1. Visual check of connector portion, contact force inspection
Check the connector of computer unit according to visual check and the contact force check point described in former page.
2. Computer unit earth connecting inspection
Remove the connector of computer unit, and then measure the applied voltage between each power source terminal, each earth connector and body earth connecting.
SPECIFIED VALUE: Voltage of each power supply terminal

CAUTION

- At the computer unit circuit check, there may be cases when the malfunction disappears by removing and installing the connectors, due to change of contact condition. Accordingly, when the result of computer unit circuit check is normal, judge that computer unit is malfunctioned after confirming the malfunction again by connecting the computer unit connector.

12-5 HANDLING INSTRUCTION OF SYSTEM

1. The computer unit, sensors, etc. are precision parts. Be very careful not to give strong impacts to those parts during the installation and removal. Never use those parts which impacts have been given (For example, in case where the parts were dropped on the floor).
2. When the test is carried out on rainy day or the vehicle is washed, care must be exercised so that no water may be admitted and the computer unit, connectors, sensors, actuators, etc. may not get wet.
3. In cases where the computer unit was judged to be malfunctioning and the vehicle has been remedied by replacing it, install the removed computer unit (Which has been judged to be malfunctioning) again to confirm that the original malfunction is reproduced. Then the computer unit can be finally judged to have been malfunctioning.

13 INSTRUCTIONS FOR RADIO INSTALLATION

CAUTION

- For those motor vehicles equipped with a mobile communication system, such as a bidirectional wireless telephone and cellular phone, be sure to observe the following precautionary measures.

1. Install the antenna as far away as possible from electronic control system.
2. As the electromagnetic wave is radiated from antenna feeder, set the antenna feeder within the distance at least not less than 300 mm apart from computer unit and ECU harness. Do not arrange both line in parallel for long distance.
3. Never bind the antenna feeder together with the engine harness with binding tape.
4. Regulate the antenna and the feeder to get rid of radio interference.
5. Never install a strong mobile communication system (Exceeding 10 kW).

14 HANDLING INSTRUCTIONS ON CATALYTIC CONVERTER-EQUIPPED VEHICLES

1. Use only unleaded gasoline to catalytic converter—equipped vehicles.
2. Utmost care must be paid as to the following points, for the catalyst will be damaged if a large amount of unburned gasoline flows into the catalytic converter.
 - (1) Do not operate the engine with the fuel in the fuel tank almost empty.
 - (2) The spark jump test must be limited to cases where such test is absolutely necessary. Also, be sure to finish the test in the shortest possible time.
 - (3) The spark check of the spark plug and engine compression pressure measurement must be performed with the fuel pump relay and injector connector disconnected and fuel injection stopped.
3. Do not dispose the waste catalyst along with parts contaminated with gasoline or oil.

15 PRECAUTION FOR VEHICLES EQUIPPED WITH SRS AIRBAG AND SEAT BELT PRETENSIONER

15-1 INSTRUCTIONS FOR SERVICE OPERATION

Be sure to perform the service operation for the vehicle equipped with the airbag and seat belt pretensioner according to the correct procedure and method, otherwise, the airbag or pretensioner may occur the malfunction and lead serious accidents during the service operation. Be sure to perform the service operation according to the correct procedure and method described in this manual.

15-1-1 DISCONNECTING THE POWER SUPPLY

1. Check the diagnosis code, and then disconnect the battery negative (-) terminal with the IG switch in LOCK position. Wait for 60 seconds to start work operation.
 - (1) The SRS airbag system is provided with a backup condenser (For the squib). Therefore, allow approx. 60 seconds for the backup condenser to discharge after the battery negative (-) terminal is removed. (Natural discharge)
 - (2) If work is started within 60 seconds, the air bag and the pretensioner may be activated.
 - (3) The memory of some systems will be erased when the battery negative (-) terminal is removed. Therefore, record memory contents of each system, as required, and input them after the work operation is complete.
2. Turn the IG switch to LOCK and connect the battery negative (-) terminal.

15-1-2 PRECAUTION PRIOR TO SERVICE OPERATION

1. For electrical checks, ensure that a digital circuit tester is used that meets the following standard.

WARNING

- If the tester to be used exceeds the specified value, the airbag and the pretensioner may be activated or damaged.

SPECIFIED VALUE: About 50 mA (0.05A) or less

NOTE

- Always measure the current value of the tester to be used before starting work operation to ensure that the tester satisfies the specified value.
- When performing the current measurement for the tester, use the minimum range of the resistance (Ω).

A1-27

2. When any of the components is removed from the air bag system (Including disconnection of the connector), ensure that the connector is removed in advance so that no accident will be caused inadvertently.
3. Follow instructions given on the label. Replace a stained or damaged label with a new one.
4. Never disassemble.
5. If the part has been dropped or exhibits a crack, dent or chips, replace with a new part.
6. Never use the parts from other vehicles. Always install a new part for replacement.
7. Do not expose parts directly to high temperatures or fire.
8. Even if the airbag and/or the pretensioner have not been activated in a collision, always perform diagnostic checks.
9. Do not apply grease. Prevent detergent, oil, water, etc. from adhering. If this happens, wipe it off immediately with dry cloth.
10. Store in places which are less likely to be exposed to electrical noise, and are not exposed to high temperatures (85°C or higher atmospheric temperatures), or high humidity.
11. Ensure that the airbag is activated with the SST, when the vehicle or the single part is discarded.
12. Never measure the resistance of the air bag components.

WARNING

- This is very dangerous, for the tester's current may activate the air bag and the pretensioner.

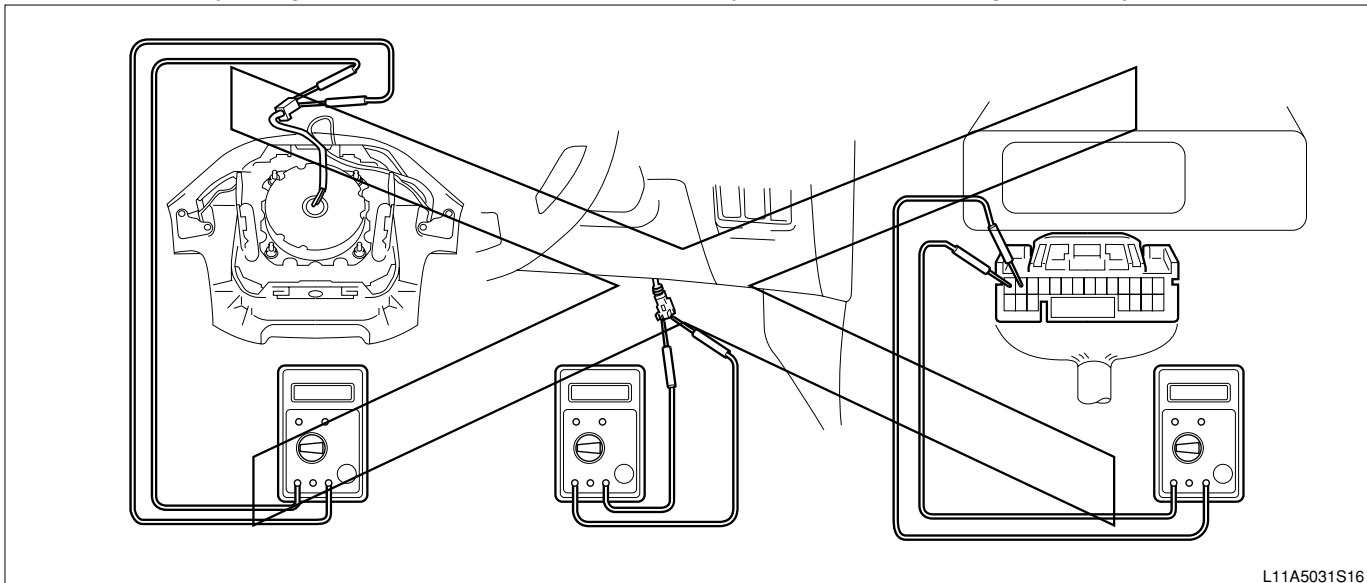

15-1-3 CAUTIONS WHEN DISCARDING THE AIR BAG AND THE PRETENSIONER

(1) Before deployment

1. Never scrap the system before activated and deployed.
2. The activation and deployment should be performed at an outdoor flat place where safety can be ensured. Avoid performing this operation in a residential area whenever possible.
3. Since the activating and deploying sound is fairly large, inform persons in the vicinity of the event before those devices are activated.
4. Use the SST and keep at least 5m away from the air bag and the pretensioner to perform a deployment operation.
5. Static electricity may activate deployment. Therefore touch steel frame, vehicle body, etc. that creates earth with bare hands to remove static electricity.
6. During deployment operation, carefully prevent the deployment side from facing down.

(2) After operation

- 1.The temperatures of some portions exceed a few hundred °C. Therefore, leave them at least 30 minutes after they are deployed.
- 2.Do not splash water.
- 3.Wear dust protective goggles and gloves during operation.
- 4.Place in a clear durable plastic bag and seal the bag to be scrapped.
- 5.After completion of the operation, be sure to wash your hands with water.

15-1-4 CAUTION TIPS FOR BODY REPAIR AND PAINT

- 1.When repairing components located close to the airbag system, ensure that the system will not be exposed to a strong hammering shock or high heat.
- 2.When using an electric welder, remove the air bag system before starting work.
- 3.When the system is expected to be exposed to a shock or high heat, remove the components from the airbag system before starting work.
- 4.When coating near the airbag system components is to be dried, ensure that temperature will not exceed 85°C.
- 5.If the airbag system components have external damage or deformation, replace with new ones.

15-1-5 CASES WHERE THE AIRBAG AND THE PRETENSIONER NEED CHECKING

- 1.When the vehicle is damaged in a collision, including cases where no deployment or activation has occurred
- 2.When the diagnostic code is outputted:

15-1-6 CAUTIONS FOR THE AIRBAG AND THE PRETENSIONER

When temporarily placing the airbag during repair work, ensure that the deployment side faces upward. Do not put something on the airbag or lay one airbag on another.

WARNING

- If the airbag should be deployed with the metal side facing upward, a serious accident may result.

15-1-7 CAUTIONS FOR SPIRAL CABLE

When the spiral cable is installed, or the steering wheel is installed/removed, be sure to perform centering.

CAUTION

- If the steering wheel is operated without centering, the spiral cable may be cut.

15-1-8 CAUTIONS FOR WIRE HARNESS AND CONNECTOR

All the connectors and the dedicated branch harnesses of the airbag system are colored in yellow, with the exception of exposed portions in the engine compartment. These connectors are special and require special care in handling in order to prevent any damage.

(1) Connector mechanism

① Terminal double lock mechanism

1. The mechanism provides better gripping force of the terminal so as to prevent the terminal from falling.
2. The connector has a two-piece construction consisting of a housing and a spacer, which doubly secures the terminal with the use of the lance (Primary lock) and the spacer (Secondary lock).

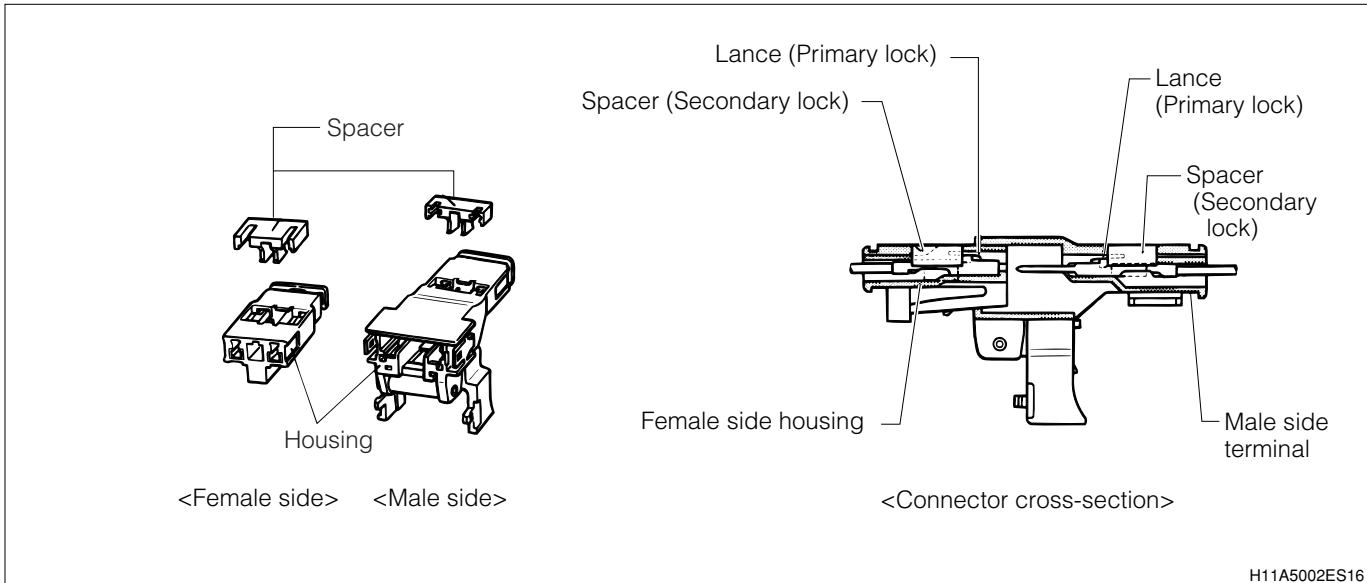

② Terminal short mechanism

1. The mechanism that automatically creates a short-circuit between the terminal on power supply side of the airbag and the terminal on the earth side, when the connector is removed.
2. The short spring plate is installed inside the connector, which creates a closed circuit on the airbag side (Potential difference between the terminals is not created), thereby preventing wrong operation during servicing.

CAUTION

- When checking the harness, the terminal's short-circuit mechanism might lead to incorrect diagnosis, such as a short-circuit condition between the harnesses. When checking the harness, insert the airbag deployment SST (Part number: 09082-87710-000, 09082-00760-000) into the connector to be checked, and check the harness while the SST is connected. If this checking finds faulty condition in the harness, insert an insulator between the short spring plate and the terminal, or remove the short spring plate, and then proceed to checking.

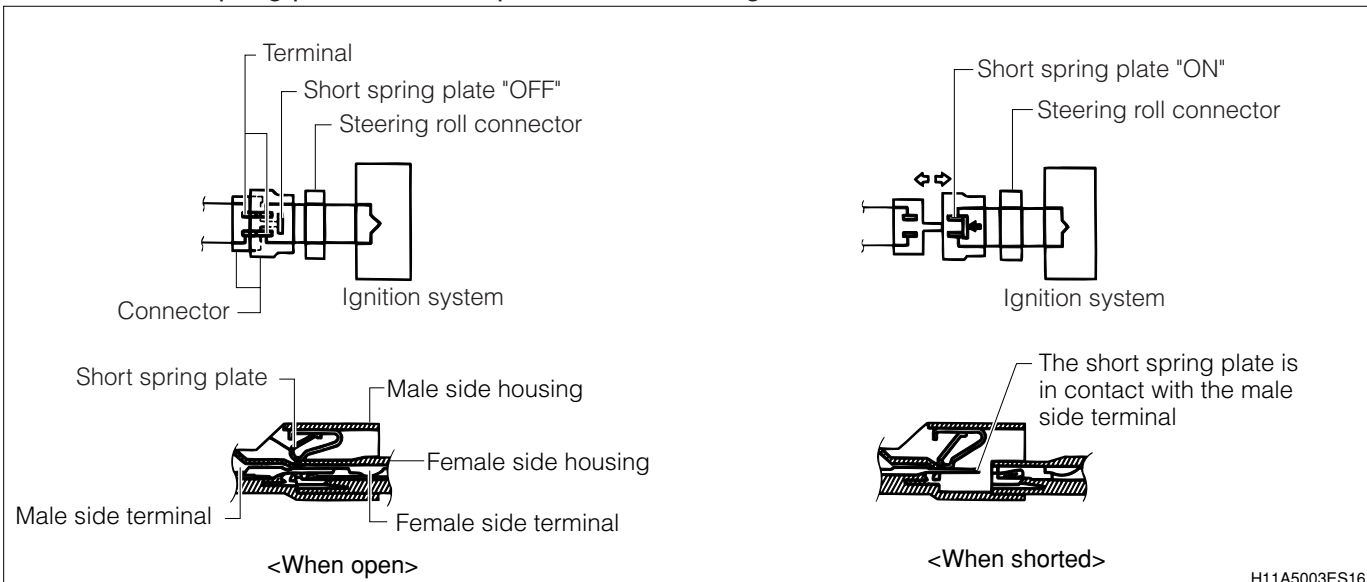

③ Half fit detecting mechanism

1. This is a mechanism which detects whether the airbag ECU is firmly connected with the vehicle side harness connector.
2. When the IG SW is turned ON with the connector half-fit, the airbag warning lamp will remain illuminated.
3. When the airbag system is normal and the connector is firmly connected, the airbag warning lamp is turned off.

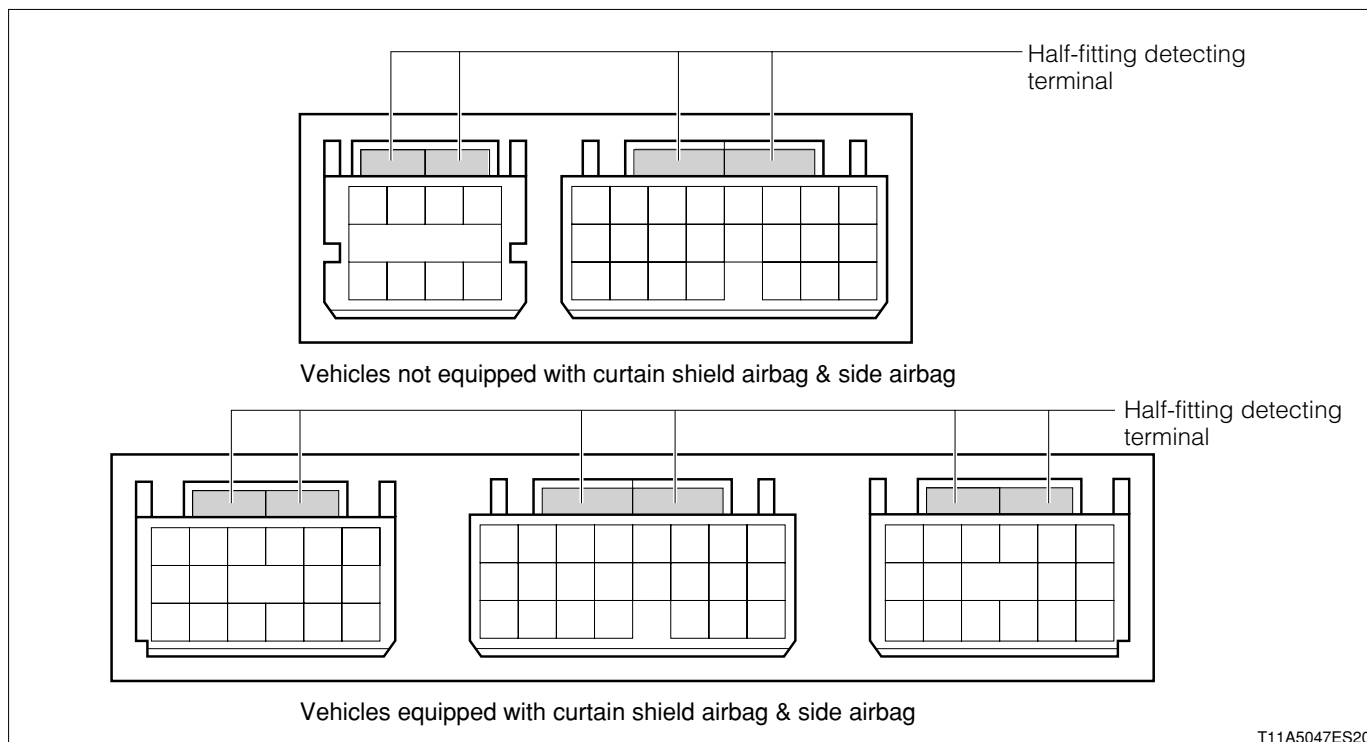

A1-31

16 VEHICLE IDENTIFICATION

16-1 BODY COLOR CODE

Body color name	Color code
White	W09
Silver metallic	S28
Black mica metallic	X07
Red	R40
Medium coral metallic	R43
Champagne metallic opal	T17
Lime green metallic	G40
Dark blue mica metallic	B42
Light blue metallic opal	B57

Body color name	Daihatsu	AKZO	DUPONT	GLASURIT	NEXA AUTO COLOR	SPIES HECKER	STANDOX	SHERWIN WILLIAMS
White	W09	DAHW09	K9344	DAI-W09	XM48	16461	W09	—
Silver metallic	S28	DAHS28	P6815	DAI-S28	2DFMB	88345	S28	—
Black mica metallic	X07	DAHX07	X1233	DAI-X07	4AFDB	747769	X07	70951
Red	R40	DAHR40	P6814	DAI-R40	2DFLB	88346	R40	—
Medium coral metallic	R43	DAHR43	X1503	DAI-R43	4RYGB	750146	R43	70947
Champagne metallic opal	T17	DAHT17	P9633	DAI-T17	2LJXB	100456	T17	—
Lime green metallic	G40	DAHG40	X1502	DAI-G40	4RYFB	750145	G40	70942
Dark blue mica metallic	B42	DAHB42	F7984	DAI-B42	MXR2B	56568	B42	—
Light blue metallic opal	B57	DAHB57	X1501	DAI-B57	4RYEB	750144	B57	70941

16-2 VEHICLE IDENTIFICATION NUMBER

1. The vehicle identification number is stamped on the position as shown in the illustration.

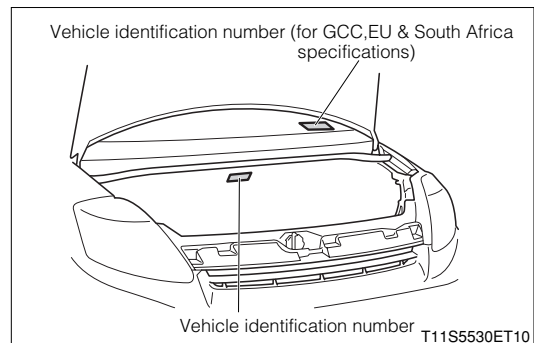

16-3 ENGINE TYPE AND ENGINE NUMBER

1. The engine type and engine number are given on the places as shown in the illustration.

1KR engine

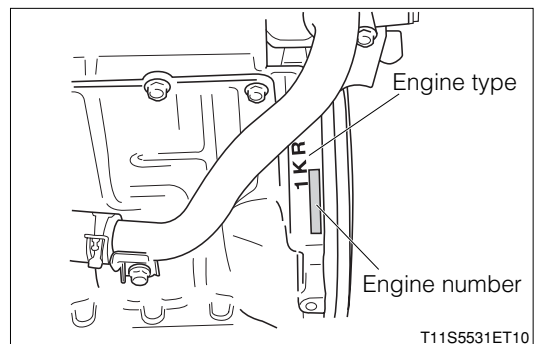

K3 engine

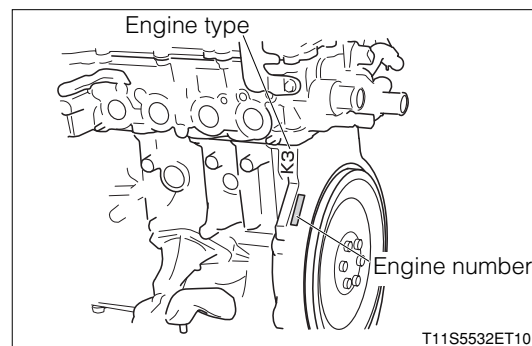

16-4 MANUFACTURER'S PLATE POSITION

1.The manufacturer's plate is given on the place as shown in the illustration.

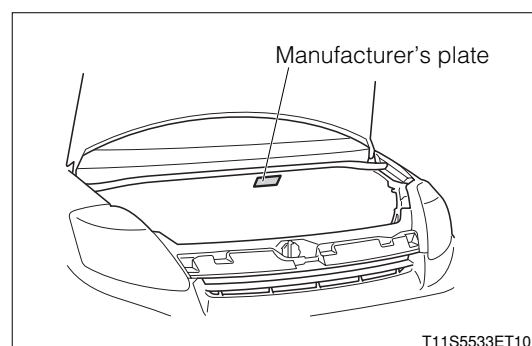

16-4-1 CONTENTS OF MANUFACTURER'S PLATE

(1) General, Australia,GCC and South Africa specifications

No.	Contents of indication
①	Manufacturer's name, Country
②	Vehicle model
③	Vehicle identification number
④	Engine type
⑤	Engine displacement
⑥	Body colors
⑦	Trim code
⑧	Production month – year (Only for Aus spec.)
⑨	Engine number
⑩	Manufacturer's name in Japanese

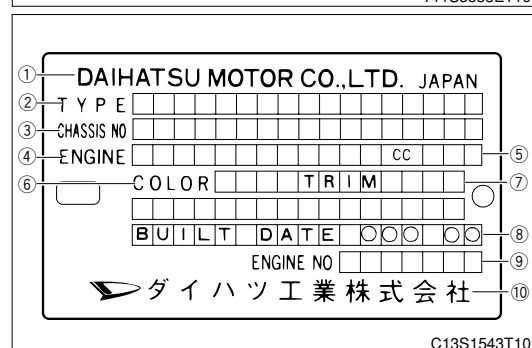

(2) EU and Algeria specifications

No.	Contents of indication
①	Manufacturer's name
②	Authorized number of WVTA
③	Vehicle identification number
④	Gross vehicle weight
⑤	Gross combination weight
⑥	Maximum permissible front axle weight
⑦	Maximum permissible rear axle weight
⑧	Vehicle model
⑨	Engine type
⑩	Body colors

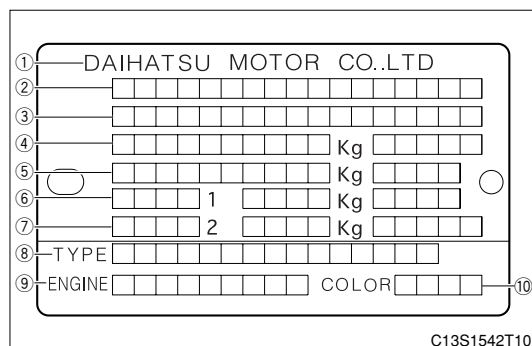

16-5 CERTIFICATION REGULATION PLATE POSITION

1. The certification regulation plate is given on the place as shown in the illustration.

16-5-1 CONTENTS OF CERTIFICATION REGULATION PLATE

(1) GCC specifications

No.	Contents of indication
①	Manufacturer's name, Country
②	Production month – year
③	GVM
④	GAW
⑤	GAW FR
⑥	GAW RR
⑦	Statement of conformity with Gulf Standards
⑧	Vehicle identification number
⑨	Vehicle category